

(19) World Intellectual Property Organization
International Bureau



(43) International Publication Date
22 July 2010 (22.07.2010)

PCT

(10) International Publication Number
WO 2010/083256 A1

(51) International Patent Classification:
B64D 9/00 (2006.01)

(21) International Application Number:
PCT/US2010/020948

(22) International Filing Date:
13 January 2010 (13.01.2010)

(25) Filing Language: English

(26) Publication Language: English

(30) Priority Data:
61/144,378 13 January 2009 (13.01.2009) US

(72) Inventor; and

(71) Applicant : NELSON, Donald, M. [US/US]; 8990 La Serena Drive, Fair Oaks, CA 95628 (US).

(74) Agent: SCHWEDLER, Carl, J.; Bullivant Houser Bailey PC, 1415 L Street, Suite 1000, Sacramento, CA 95814 (US).

(81) Designated States (unless otherwise indicated, for every kind of national protection available): AE, AG, AL, AM,

AO, AT, AU, AZ, BA, BB, BG, BH, BR, BW, BY, BZ, CA, CH, CL, CN, CO, CR, CU, CZ, DE, DK, DM, DO, DZ, EC, EE, EG, ES, FI, GB, GD, GE, GH, GM, GT, HN, HR, HU, ID, IL, IN, IS, JP, KE, KG, KM, KN, KP, KR, KZ, LA, LC, LK, LR, LS, LT, LU, LY, MA, MD, ME, MG, MK, MN, MW, MX, MY, MZ, NA, NG, NI, NO, NZ, OM, PE, PG, PH, PL, PT, RO, RS, RU, SC, SD, SE, SG, SK, SL, SM, ST, SV, SY, TH, TJ, TM, TN, TR, TT, TZ, UA, UG, US, UZ, VC, VN, ZA, ZM, ZW.

(84) Designated States (unless otherwise indicated, for every kind of regional protection available): ARIPO (BW, GH, GM, KE, LS, MW, MZ, NA, SD, SL, SZ, TZ, UG, ZM, ZW), Eurasian (AM, AZ, BY, KG, KZ, MD, RU, TJ, TM), European (AT, BE, BG, CH, CY, CZ, DE, DK, EE, ES, FI, FR, GB, GR, HR, HU, IE, IS, IT, LT, LU, LV, MC, MK, MT, NL, NO, PL, PT, RO, SE, SI, SK, SM, TR), OAPI (BF, BJ, CF, CG, CI, CM, GA, GN, GQ, GW, ML, MR, NE, SN, TD, TG).

Declarations under Rule 4.17:

— of inventorship (Rule 4.17(iv))

[Continued on next page]

(54) Title: CARGO LOADING TRAILER

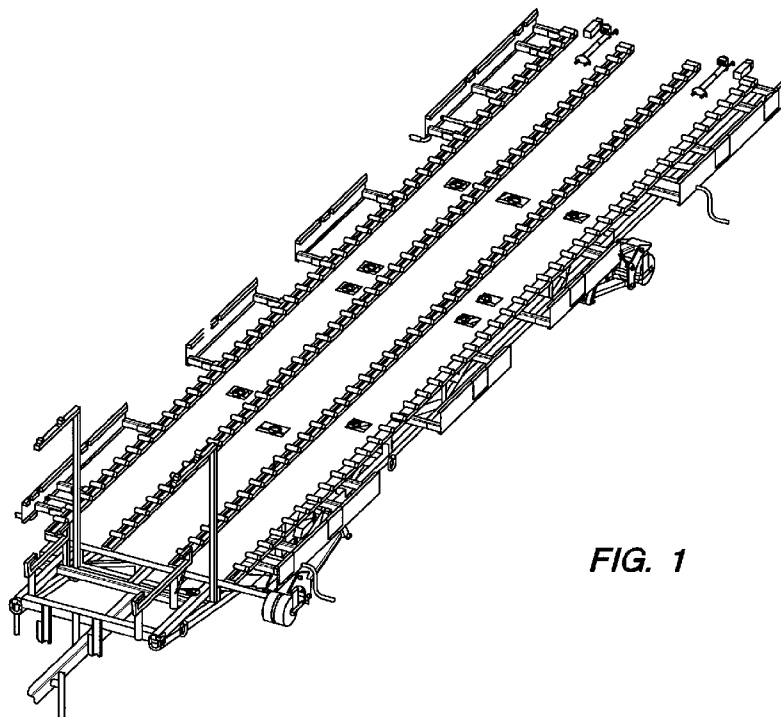

FIG. 1

[Continued on next page]



WO 2010/083256 A1

Published:

— with international search report (Art. 21(3))

(57) Abstract: A cargo loading system for loading freight into or out of the cargo hold, the system comprising: a tilt control means which can be actuated by control signals in such a way that variances in tilt of a palletized load can be immediately righted; a control panel for actuation by personnel; a power source to the control panel; and a trailer base connected to the tilt control means for accepting freight.

CARGO LOADING TRAILER

Reference to Related Application

[0001] This application claims the benefit of United States Provisional Patent Application No. 61/144,378, filed January 13, 2009, the complete disclosure of which is incorporated herein, in the entirety.

Copyright Notice

[0002] A portion of the disclosure of this patent document contains material which is subject to copyright protection. The copyright owner has no objection to the facsimile reproduction by anyone of the patent document or the patent disclosure, as it appears in the Patent and Trademark Office patent files and records, but otherwise reserves all other copyright rights.

BACKGROUND OF THE INVENTION

Field of the Invention

[0003] This invention describes a freight-loading system adapted particularly for use in loading a portable airborne firefighting system (AFFS) to the fuselage or cargo hold of an aircraft.

Description of Related Art

[0004] United States Patent No. 7,165,627, discloses a portable AFFS that is adapted for use in a host aircraft fuselage. The firefighting apparatus includes a pressurizeable retardant tank disposed in the interior of the host aircraft, the retardant tank being capable of roll-on and roll-off installation, an ejection tube in fluid communication with the retardant tank, and a door plug for mounting within a fuselage orifice in the host aircraft. The door plug provides for fluid communication of retardant from the retardant tank through the ejection tube to the exterior of the host aircraft. At least one sensor is operably connected to the firefighting apparatus to effect user-discernable data for effecting retardant delivery. The system is secured to a pallet which is loaded on and off the fuselage in a conventional manner.

[0005] In the loading and unloading of an AFFS, a large holding tank, pressurizing

system, controls, and various pipes and structural components are first secured to a pallet structure. The resulting pallet is very large, bulky and cumbersome to move in an out.

[0006] United States Patent No. 6,867,702, describes a freight-loading system located within the cargo hold of an aircraft for enhanced operating safety. The freight-loading system comprises a plurality of power drive units (PDUs), which can be actuated by control signals in such a way that items of freight can be maneuvered into or out of the cargo hold as well as within it. The PDUs are connected by control leads to control panels for actuation by personnel. A control maintenance computer (CMC) is provided and connected to the PDUs and the control panels, and is so designed that status information from the PDUs and the control panels can be read out and that the PDUs and/or the control panels are controllable by the CMC. This system is not adapted for, nor could it accommodate a bulky structure that is intended to occupy a substantial portion of the fuselage.

[0007] None of the prior art approaches have been able to improve the loading of a large palletized structure such as a portable AFFS safely and quickly.

SUMMARY OF THE INVENTION

[0008] This invention provides a palletized structure loading system that includes a tilt control to prevent tilt and maintain horizontal and vertical alignment of the pallet during loading.

[0009] This invention also provides a cargo loading system for loading freight into or out of the cargo hold, the system comprising: a tilt control means which can be actuated by control signals in such a way that variances in tilt of a palletized load can be immediately righted; a control panel for actuation by personnel; a power source to the control panel; and a trailer base connected to the tilt control means for accepting freight.

[0010] The cargo loading system may have the cargo loaded to a pallet.

[0011] The cargo loading system can be adapted particularly for loading and unloading an AFFS system.

[0012] These and other features and advantages of this invention are described in, or are apparent from, the following detailed description of various exemplary embodiments of the apparatus and methods according to this invention.

BRIEF DESCRIPTION OF THE DRAWINGS

[0013] A more complete understanding of the present invention and the attendant features and advantages thereof may be had by reference to the following detailed description when considered in conjunction with the accompanying drawings wherein:

[0014] Figure 1 depicts perspective views of the trailer components.

[0015] Figure 2 depicts the trailer in perspective and showing details of the actuators.

[0016] Figure 3 is a top plan view of the cargo loading trailer showing location of the tilt switches.

[0017] Figure 4 is a front end view of the trailer

DETAILED DESCRIPTION OF THE INVENTION

[0018] The products and methods of the present invention provide an improved cargo loading trailer adapted for the loading of a large palletized structure such as a mobile or portable AFFS both safely and quickly from the fuselage of an aircraft.

[0019] Before the present invention is described in greater detail, it is to be understood that this invention is not limited to particular embodiments described, as such may, of course, vary. It is also to be understood that the terminology used herein is for the purpose of describing particular embodiments only, and is not intended to be limiting, since the scope of the present invention will be limited only by the appended claims.

[0020] Unless defined otherwise, all technical and scientific terms used herein have the same meaning as commonly understood by one of ordinary skill in the art to which this invention belongs. Although any methods and materials similar or equivalent to those described herein can also be used in the practice or testing of the present invention, the preferred methods and materials are now described.

[0021] All publications and patents cited in this specification are herein incorporated by reference as if each individual publication or patent were specifically and individually indicated to be incorporated by reference and are incorporated herein by reference to disclose and describe the methods and/or materials in connection with which the publications are cited. The citation of any publication is for its disclosure prior to the filing date and should not be construed as an admission that the present invention is not entitled to antedate such publication by virtue of prior invention. Further, the dates of publication provided may be different from the

actual publication dates which may need to be independently confirmed.

[0022] It must be noted that as used herein and in the appended claims, the singular forms “a”, “an”, and “the” include plural references unless the context clearly dictates otherwise. It is further noted that the claims may be drafted to exclude any optional element. As such, this statement is intended to serve as antecedent basis for use of such exclusive terminology as “solely,” “only” and the like in connection with the recitation of claim elements, or use of a “negative” limitation.

[0023] As will be apparent to those of skill in the art upon reading this disclosure, each of the individual embodiments described and illustrated herein has discrete components and features which may be readily separated from or combined with the features of any of the other several embodiments without departing from the scope or spirit of the present invention. Any recited method can be carried out in the order of events recited or in any other order which is logically possible.

[0024] In the loading and unloading of an AFFS, it is necessary to deposit a bulky load within the fuselage of an aircraft, typically including a large holding tank, pressurizing system, controls, and various pipes and structural components. In the past, this has been accomplished by first securing the components to a pallet structure, which is large, bulky and cumbersome to move in and out of the aircraft fuselage, and then using conventional lifting operations to lift the pallet to the fuselage.

[0025] In reference now to the Figures appended herewith, the present invention provides a palletized structure loading system 10 that incorporates tilt control means to prevent tilt and maintain horizontal and vertical alignment of a pallet during loading, providing enhanced control and safety of the operation of loading palleted freight into or out of the cargo hold or fuselage of an aircraft.

[0026] The components of the cargo loading system 10 include a trailer base 20 for accepting palleted freight, which is connected to a tilt control means 30 which can be actuated by control signals in such a way that variances in tilt of a palletized load can be immediately righted. The system also includes a power source and a control panel for actuation by personnel.

[0027] Tilt switches, for instance the use of an inclinometer or the like, are adapted to maintain level in a palletized AFFS trailer system. The tilt switches allow control of four vertically articulated casters 40, 41, 42 and 43, that are hydraulically actuated are used to

maintain proper orientation in loading in response to signals from the tilt control means 30. A combination of single axis or a dual axis tilt sensor may be utilized.

[0028] As seen in Figure 2, the tilt control means 30 may include a control box 50, such as the Loadmaster control box 50, which allows single point control of height adjustment and steering capability. The trailer can also be equipped with an external aircraft 28 V DC ground power receptacle 60.

[0029] Twin 12 V batteries can be used within (not shown) to supply power to the winch and hydraulic system. The controls may also include a 28 V DC auxiliary ground power receptacle 61. A toggle switch 62 may be provided for switching between on and off positions for the power.

[0030] In one adaptation, four tilt switches are deployed within the control box 50, such as Fredericks Programmable Tilt Switch, model no. 0729-1727-99, a non-mercury, single axis, programmable tilt switch. Such a switch utilizes a +4.5 to +28 volt single power supply, with a +45 degree sensing range. The Fredericks Programmable Tilt Switch also utilizes unidirectional and bi-directional open collector outputs.

[0031] A preferred Fredericks Programmable Tilt Switch is a combination microprocessor based electronics and TrueTilt™ dual axis tilt sensor in a compact, high-impact plastic case. The design provides the user with anon-mercury, field settable switch solution for many applications. The tilt switch assembly can be easily custom configured for a wide variety of angle range trip points, to avoid the wide hysteresis errors of most mercury and gravity ball switches over temperature. The simple design makes it cost effective for prototype and production requirements.

[0032] Further adaptations may include a vehicle tip-over protection/warning, alarm system activation, structural threshold monitoring, and safety cut off switch.

[0033] The programming and operation of a Fredericks Programmable Tilt Switch allows each unit to be programmed to trip at any point within its angle range. This is accomplished very simply by applying power and inserting and removing a jumper at the starting and trip point. Unidirectional output will trip in one direction only. Bidirectional output will trip in both directions. The unit can be reprogrammed as often as necessary for any application.

[0034] The fore and aft steerable casters allow direct Loadmaster control. Preferably the system casters comprise aerospace grade rollers fitted with sealed bearings.

[0035] The use of flared ends and rollers 70 can be included to facilitate ease of loading of pallets onto the trailer base 20. Further, D-rings 80, allow the tying of the loaded pallet to the trailer base 20.

[0036] The system 10 also includes surge brakes 90 for towing safety (Figure 2). Forward and aft stops can be provided to prevent cargo movement during transportation.

[0037] Optionally, an onboard 24-volt remote control winch 100 may provide for easing of the loaded pallets on and off of the trailer bed 20.

[0038] For safety purposes, it may be preferred to include reflective tape along exterior for night visibility. Also for safety purposes, side stops 110 are provided to keep the pallet on the trailer bed 20.

[0039] In operation, the tilt switches are used to limit the amount of tilt in the system 10 when raising or lowering the loaded trailer bed 20. After the trailer is moved to a loading position (for instance by using normal tires affixed beneath the trailer, not shown), the casters 40, 41, 42 and 43 are lowered to the ground and then begin to raise the trailer bed 20 off of the tires to raise a loaded pallet to the proper height. After this, the trailer system 10 is steered a final distance with the controlled casters so that is properly aligned with the aircraft.

[0040] The loaded system 10 is then winched from the trailer rollers 70 onto the aircraft rollers.

[0041] The trailer tongue 120 can also be used to control and manually steer the trailer by attaching it in a conventional manner.

[0042] The trailer system 10 may also be provided with four adjustable landing pads for safe, secure footing on varying grades and terrain.

[0043] The tilt control system 30, by inclinometer or switches or the like, provides a horizontal and vertical control to allow safe alignment of the trailer to a C-130 cargo aircraft for proper loading and unloading of the system.

[0044] The cargo loading trailer system 10 may also be used as a platform for AFFS storage, testing, pre-flight inspection, and transport.

[0045] The trailer 10 may be produced to be compatible with a particular cargo floor for air transportation, for instance a C-130 cargo floor.

[0046] Optionally, the cargo loading trailer can utilize fold-up sides to reduce the width for aircraft loading and crew egress. The fold up sides allows the cargo loading trailer to

be used for a wide of range of logistical solutions.

[0047] Remote controlled steerable casters may be located on one or the other side of the trailer and assist in maneuvering the trailer.

[0048] A trailer built to the specifications exemplified can be used for transportation and storage of standard 463L pallets or other variants not exceeding 108” in width.

[0049] A C-130 system can also be produced to be compatible with the Lockheed Martin L-382/L-100 and other rear loading cargo aircraft.

[0050] The cargo loading trailer can also be modified to accommodate most other aircraft with rear cargo loading, for example the Alenia C-27J, CASA C-295, CN-235 and Airbus A400M.

[0051] A secure storage box that is used to store loose items, i.e. pallet stops and tools, may be attached to the system 10.

Examples – Trailer dimensions

[0052] The cargo loading system can be easily adapted particularly for loading and unloading an ADFS system for a C-130 fuselage. For such an application, trailer dimensions are as follows:

[0053]	Trailer Length	551 inches approximately
[0054]	Trailer Length with Extension	595 inches approximately
[0055]	Minimum Width	99 inches approximately
[0056]	Maximum Width	113 inches approximately

[0057] While this invention has been described in conjunction with the specific embodiments outlined above, it is evident that many alternatives, modifications and variations will be apparent to those skilled in the art. Accordingly, the preferred embodiments of the invention, as set forth above, are intended to be illustrative, not limiting. Various changes may be made without departing from the spirit and scope of this invention.

CLAIMS

What is claimed is:

- 1 1. A cargo loading system for loading freight into or out of the cargo hold, the system
2 comprising:
 - 3 a tilt control means which can be actuated by control signals in such a way that variances
4 in tilt of a palletized load can be immediately righted;
 - 5 a control panel for actuation by personnel;
 - 6 a power source to the control panel;
 - 7 a tilt limiting sensor; a winch for loading pallets onto the trailer; and
 - 8 a trailer base connected to the tilt control means for accepting freight.
- 1 2. The cargo loading system of Claim 1, wherein the cargo hold is for an aircraft.
- 1 3. The cargo loading system of Claim 2, wherein the aircraft is a rear loading aircraft.
- 1 4. The cargo loading system of Claim 3, wherein the aircraft is a C-130.
- 1 5. The cargo loading system of Claim 3, wherein the aircraft is a Lockheed Martin L-382/L-
2 100.
- 1 6. The cargo loading system of Claim 3, wherein the aircraft is an aircraft selected from the
2 group of aircraft consisting of an Alenia C-27J, a CASA C-295, a CN-235 and an Airbus A400M.
- 1 7. The cargo loading system of Claim 2, wherein the pallet is adapted to hold an ADFS unit.
- 1 8. The cargo loading system of Claim 2, wherein the pallet is adapted to transport and store
2 a pallet at least about 99" in width.
- 1 9. The cargo loading system of Claim 8, wherein the pallet is adapted to transport and store
2 a pallet at least about 108" in width.
- 1 10. The cargo loading system of Claim 9, wherein the pallet is adapted to transport and store
2 a pallet at least about 113" in width.
- 1 11. The cargo loading system of Claim 2, wherein the pallet is adapted to transport and store
2 a standard 463L pallet.
- 1 12. The cargo loading system of Claim 2, wherein the trailer has a length of at least about
2 500 inches.
- 1 13. The cargo loading system of Claim 12, wherein the trailer has a length of at least about
2 551 inches.

1 14. The cargo loading system of Claim 13, wherein the trailer has a length of at least about
2 595 inches.

1 15. The cargo loading system of Claim 1, wherein the tilt limiting sensor is a tilt switch.

1 16. The cargo loading system of Claim 15, wherein the tilt switch is a non-mercury, single
2 axis, programmable tilt switch.

1 17. The cargo loading system of Claim 15, wherein the tilt switch has a +45 degree sensing
2 range.

1 18. The cargo loading system of Claim 15, wherein the tilt switch utilizes unidirectional and
2 bi-directional open collector outputs.

1 19. The cargo loading system of Claim 1, further comprising tip-over protection/warning,
2 alarm system activation.

1 20. The cargo loading system of Claim 1, further comprising tip a safety cut off switch.

1/4

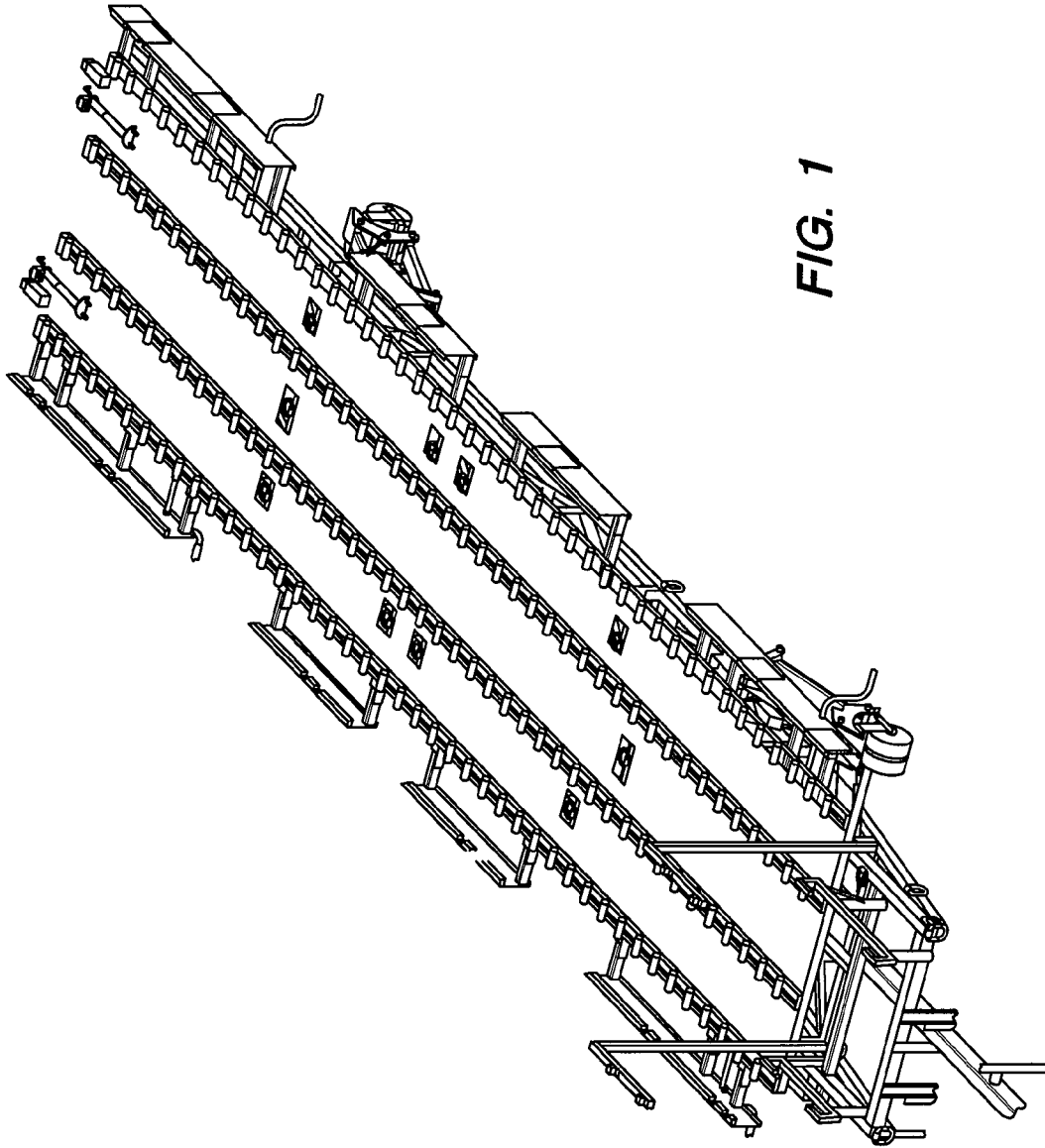
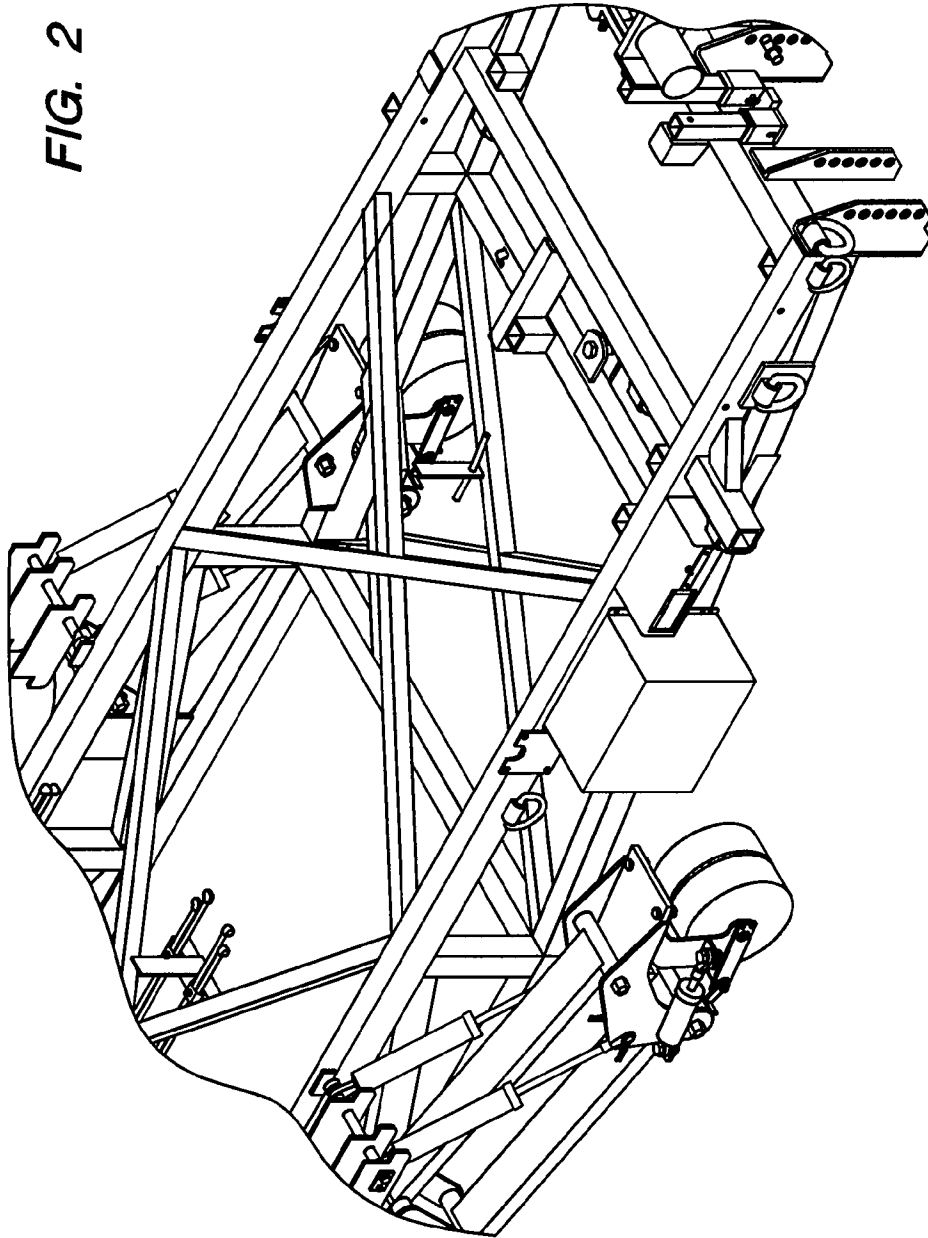

FIG. 1

FIG. 2



3/4

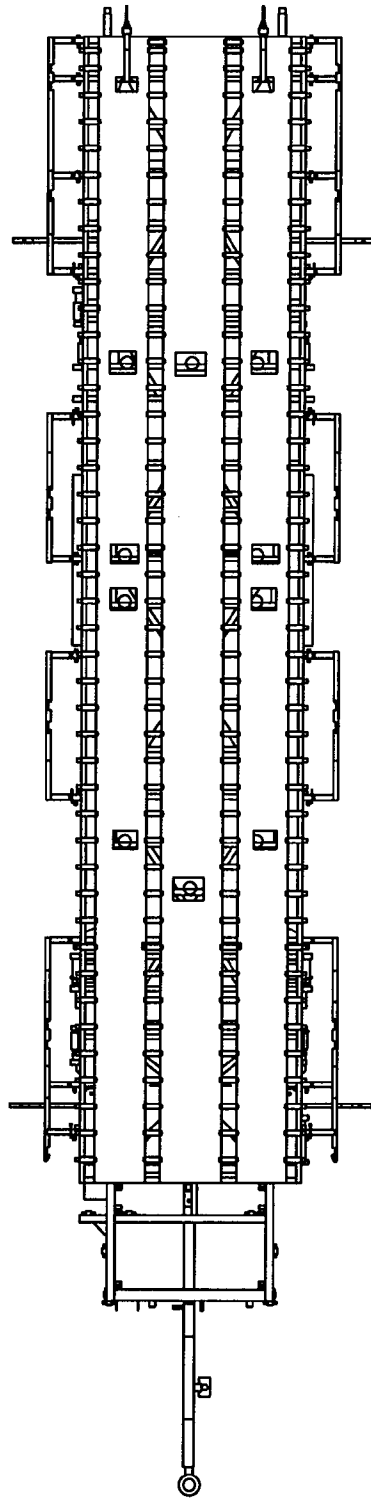

FIG. 3

4/4

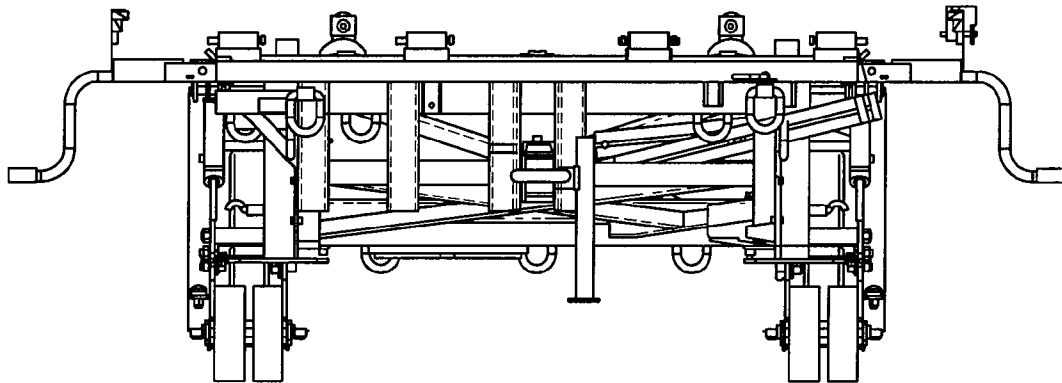

FIG. 4

INTERNATIONAL SEARCH REPORT

International application No.
PCT/US2010/020948

A. CLASSIFICATION OF SUBJECT MATTER
 IPC(8) - B64D 9/00 (2010.01)
 USPC - 198/572
 According to International Patent Classification (IPC) or to both national classification and IPC

B. FIELDS SEARCHED

Minimum documentation searched (classification system followed by classification symbols)
 IPC(8) - B64D 9/00; B64C 1/20, 1/22; B65G 13/02 (2010.01)
 USPC - 198/572, 781.06, 782

Documentation searched other than minimum documentation to the extent that such documents are included in the fields searched

Electronic data base consulted during the international search (name of data base and, where practicable, search terms used)
 MineSoft PatBase

C. DOCUMENTS CONSIDERED TO BE RELEVANT

Category*	Citation of document, with indication, where appropriate, of the relevant passages	Relevant to claim No.
Y	US 5,511,922 A (SEKIGUCHI et al) 30 April 1996 (30.04.1996) entire document	1-20
Y	US 2007/0025832 A1 (RAWDON et al) 01 February 2007 (01.02.2007) entire document	1-20
Y	US 2006/0260826 A1 (HUTTER et al) 23 November 2006 (23.11.2006) entire document	3-11
Y	Programmable Tilt Switch Combines Microprocessor-Based Electronics and MCL Truetilt (TM) Sensor in a Compact Plastic Case; ThomasNet News press release and product information sheet; (FREDERICKS COMPANY) 29 March 2005 (29.03.2005) entire document	15-20

Further documents are listed in the continuation of Box C.

* Special categories of cited documents:	"T" later document published after the international filing date or priority date and not in conflict with the application but cited to understand the principle or theory underlying the invention
"A" document defining the general state of the art which is not considered to be of particular relevance	"X" document of particular relevance; the claimed invention cannot be considered novel or cannot be considered to involve an inventive step when the document is taken alone
"E" earlier application or patent but published on or after the international filing date	"Y" document of particular relevance; the claimed invention cannot be considered to involve an inventive step when the document is combined with one or more other such documents, such combination being obvious to a person skilled in the art
"L" document which may throw doubts on priority claim(s) or which is cited to establish the publication date of another citation or other special reason (as specified)	"&" document member of the same patent family
"O" document referring to an oral disclosure, use, exhibition or other means	
"P" document published prior to the international filing date but later than the priority date claimed	

Date of the actual completion of the international search 03 March 2010	Date of mailing of the international search report 19 MAR 2010
--	--

Name and mailing address of the ISA/US Mail Stop PCT, Attn: ISA/US, Commissioner for Patents P.O. Box 1450, Alexandria, Virginia 22313-1450 Facsimile No. 571-273-3201	Authorized officer: Blaine R. Copenheaver PCT Helpdesk: 571-272-4300 PCT OSP: 571-272-7774
---	---