

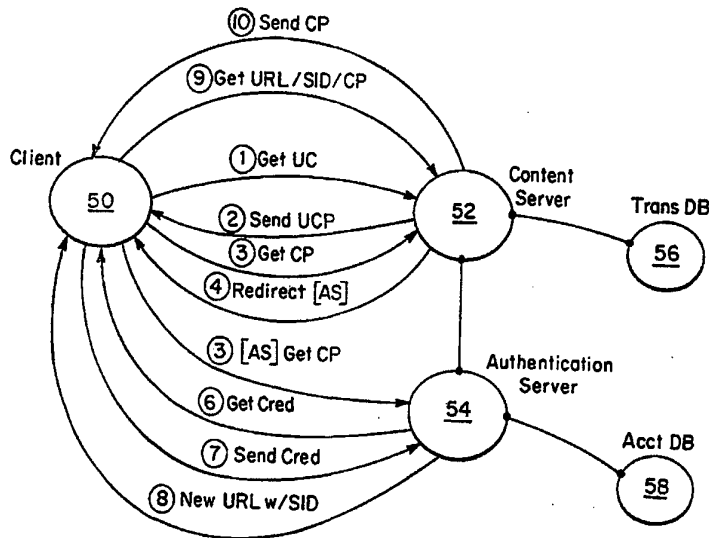

INTERNATIONAL APPLICATION PUBLISHED UNDER THE PATENT COOPERATION TREATY (PCT)

<p>(51) International Patent Classification ⁶ : G06F</p>	<p>A2</p>	<p>(11) International Publication Number: WO 96/42041 (43) International Publication Date: 27 December 1996 (27.12.96)</p>
<p>(21) International Application Number: PCT/US96/07838 (22) International Filing Date: 3 June 1996 (03.06.96) (30) Priority Data: 08/474,096 7 June 1995 (07.06.95) US 08/486,797 7 June 1995 (07.06.95) US (71) Applicant: OPEN MARKET, INC. [US/US]; 215 First Street, Cambridge, MA 02142 (US). (72) Inventors: LEVERGOOD, Thomas, Mark; 9 North Street, Hopkinton, MA 01748 (US). STEWART, Lawrence, C.; 1 Arborwood Drive, Burlington, MA 01803 (US). MORRIS, Stephen, Jeffrey; 3 Kings Pine Road, Westford, MA 01886 (US). PAYNE, Andrew, C.; 5 Lewis Street, Lincoln, MA 01773 (US). TREESE, George, Winfield; 81 Saco Street, Newton, MA 02164 (US). GIFFORD, David, K.; 26 Pigeon Hill Road, Weston, MA 02193 (US). (74) Agents: SMITH, James, M. et al.; Hamilton, Brook, Smith & Reynolds, Two Militia Drive, Lexington, MA 02173 (US).</p>		<p>(81) Designated States: AU, CA, DE, GB, IL, JP, European patent (AT, BE, CH, DE, DK, ES, FI, FR, GB, GR, IE, IT, LU, MC, NL, PT, SE). Published <i>Without international search report and to be republished upon receipt of that report.</i></p>

(54) Title: INTERNET SERVER ACCESS CONTROL AND MONITORING SYSTEMS



(57) Abstract

This invention relates to methods for controlling and monitoring access to network servers. In particular, the process described in the invention includes client-server sessions over the Internet involving hypertext files. In the hypertext environment, a client views a document transmitted by a content server with a standard program known as the browser. Each hypertext document or page contains links to other hypertext pages which the user may select to traverse. When the user selects a link that is directed to an access-controlled file, the server subjects the request to a secondary server which determines whether the client has an authorization or valid account. Upon such verification, the user is provided with a session identification which allows the user to access to the requested file as well as any other files within the present protection domain.

FOR THE PURPOSES OF INFORMATION ONLY

Codes used to identify States party to the PCT on the front pages of pamphlets publishing international applications under the PCT.

AM	Armenia	GB	United Kingdom	MW	Malawi
AT	Austria	GE	Georgia	MX	Mexico
AU	Australia	GN	Guinea	NE	Niger
BB	Barbados	GR	Greece	NL	Netherlands
BE	Belgium	HU	Hungary	NO	Norway
BF	Burkina Faso	IE	Ireland	NZ	New Zealand
BG	Bulgaria	IT	Italy	PL	Poland
BJ	Benin	JP	Japan	PT	Portugal
BR	Brazil	KE	Kenya	RO	Romania
BY	Belarus	KG	Kyrgystan	RU	Russian Federation
CA	Canada	KP	Democratic People's Republic of Korea	SD	Sudan
CF	Central African Republic	KR	Republic of Korea	SE	Sweden
CG	Congo	KZ	Kazakhstan	SG	Singapore
CH	Switzerland	LI	Liechtenstein	SI	Slovenia
CI	Côte d'Ivoire	LK	Sri Lanka	SK	Slovakia
CM	Cameroon	LR	Liberia	SN	Senegal
CN	China	LT	Lithuania	SZ	Swaziland
CS	Czechoslovakia	LU	Luxembourg	TD	Chad
CZ	Czech Republic	LV	Latvia	TG	Togo
DE	Germany	MC	Monaco	TJ	Tajikistan
DK	Denmark	MD	Republic of Moldova	TT	Trinidad and Tobago
EE	Estonia	MG	Madagascar	UA	Ukraine
ES	Spain	ML	Mali	UG	Uganda
FI	Finland	MN	Mongolia	US	United States of America
FR	France	MR	Mauritania	UZ	Uzbekistan
GA	Gabon			VN	Viet Nam

INTERNET SERVER ACCESS CONTROL AND MONITORING SYSTEMSReference to Appendix

A portion of the disclosure of this patent document contains material which is subject to copyright protection. The copyright owner has no objection to the facsimile reproduction by any one of the patent disclosure, as it appears in the Patent and Trademark Office patent files or records, but otherwise reserves all copyright rights whatsoever.

10 Background of the Invention

The Internet, which started in the late 1960s, is a vast computer network consisting of many smaller networks that span the entire globe. The Internet has grown exponentially, and millions of users ranging from individuals to corporations now use permanent and dial-up connections to use the Internet on a daily basis worldwide. The computers or networks of computers connected within the Internet, known as "hosts", allow public access to databases featuring information in nearly every field of expertise and are supported by entities ranging from universities and government to many commercial organizations.

The information on the Internet is made available to the public through "servers". A server is a system running on an Internet host for making available files or documents contained within that host. Such files are typically stored on magnetic storage devices, such as tape drives or fixed disks, local to the host. An Internet server may distribute information to any computer that requests the files on a host. The computer making such a request is known as the "client", which may be an Internet-connected

-2-

workstation, bulletin board system or home personal computer (PC).

TCP/IP (Transmission Control Protocol/Internet Protocol) is one networking protocol that permits full use
5 of the Internet. All computers on a TCP/IP network need unique ID codes. Therefore, each computer or host on the Internet is identified by a unique number code, known as the IP (Internet Protocol) number or address, and
10 corresponding network and computer names. In the past, an Internet user gained access to its resources only by identifying the host computer and a path through directories within the host's storage to locate a requested file. Although various navigating tools have helped users
15 to search resources on the Internet without knowing specific host addresses, these tools still require a substantial technical knowledge of the Internet.

The World-Wide Web (Web) is a method of accessing information on the Internet which allows a user to navigate the Internet resources intuitively, without IP addresses or
20 other technical knowledge. The Web dispenses with command-line utilities which typically require a user to transmit sets of commands to communicate with an Internet server. Instead, the Web is made up of hundreds of thousands of interconnected "pages", or documents, which can be
25 displayed on a computer monitor. The Web pages are provided by hosts running special servers. Software which runs these Web servers is relatively simple and is available on a wide range of computer platforms including PC's. Equally available is a form of client software,
30 known as a Web "browser", which is used to display Web pages as well as traditional non-Web files on the client system. Today, the Internet hosts which provide Web servers are increasing at a rate of more than 300 per month, en route to becoming the preferred method of
35 Internet communication.

-3-

Created in 1991, the Web is based on the concept of "hypertext" and a transfer method known as "HTTP" (Hypertext Transfer Protocol). HTTP is designed to run primarily over TCP/IP and uses the standard Internet setup, where a server issues the data and a client displays or processes it. One format for information transfer is to create documents using Hypertext Markup Language (HTML). HTML pages are made up of standard text as well as formatting codes which indicate how the page should be displayed. The Web client, a browser, reads these codes in order to display the page. The hypertext conventions and related functions of the world wide web are described in the appendices of U.S. Patent Application Serial No. 08/328,133, filed on October 24, 1994, by Payne et al. which is incorporated herein by reference.

Each Web page may contain pictures and sounds in addition to text. Hidden behind certain text, pictures or sounds are connections, known as "hypertext links" ("links"), to other pages within the same server or even on other computers within the Internet. For example, links may be visually displayed as words or phrases that may be underlined or displayed in a second color. Each link is directed to a web page by using a special name called a URL (Uniform Resource Locator). URLs enable a Web browser to go directly to any file held on any Web server. A user may also specify a known URL by writing it directly into the command line on a Web page to jump to another Web page.

The URL naming system consists of three parts: the transfer format, the host name of the machine that holds the file, and the path to the file. An example of a URL may be:

<http://www.college.univ.edu/Adir/Bdir/Cdir/page.html>,

-4-

where "http" represents the transfer protocol; a colon and two forward slashes (://) are used to separate the transfer format from the host name; "www.college.univ.edu" is the host name in which "www" denotes that the file being
5 requested is a Web page; "/Adir/Bdir/Cdir" is a set of directory names in a tree structure, or a path, on the host machine; and "page.html" is the file name with an indication that the file is written in HTML.

The Internet maintains an open structure in which
10 exchanges of information are made cost-free without restriction. The free access format inherent to the Internet, however, presents difficulties for those information providers requiring control over their Internet servers. Consider for example, a research organization
15 that may want to make certain technical information available on its Internet server to a large group of colleagues around the globe, but the information must be kept confidential. Without means for identifying each client, the organization would not be able to provide
20 information on the network on a confidential or preferential basis. In another situation, a company may want to provide highly specific service tips over its Internet server only to customers having service contracts or accounts.

25 Access control by an Internet server is difficult for at least two reasons. First, when a client sends a request for a file on a remote Internet server, that message is routed or relayed by a web of computers connected through the Internet until it reaches its destination host. The
30 client does not necessarily know how its message reaches the server. At the same time, the server makes responses without ever knowing exactly who the client is or what its IP address is. While the server may be programmed to trace its clients, the task of tracing is often difficult, if not
35 impossible. Secondly, to prevent unwanted intrusion into

-5-

private local area networks (LAN), system administrators implement various data-flow control mechanisms, such as the Internet "firewalls", within their networks. An Internet firewall allows a user to reach the Internet anonymously while preventing intruders of the outside world from accessing the user's LAN.

Summary of the Invention

The present invention relates to methods of processing service requests from a client to a server through a network. In particular the present invention is applicable to processing client requests in an HTTP (Hypertext Transfer Protocol) environment, such as the World-Wide Web (Web). One aspect of the invention involves forwarding a service request from the client to the server and appending a session identification (SID) to the request and to subsequent service requests from the client to the server within a session of requests. In a preferred embodiment, the present method involves returning the SID from the server to the client upon an initial service request made by the client. A valid SID may include an authorization identifier to allow a user to access controlled files.

In a preferred embodiment, a client request is made with a Uniform Resource Locator (URL) from a Web browser. Where a client request is directed to a controlled file without an SID, the Internet server subjects the client to an authorization routine prior to issuing the SID, the SID being protected from forgery. A content server initiates the authorization routine by redirecting the client's request to an authentication server which may be at a different host. Upon receiving a redirected request, the authentication server returns a response to interrogate the client and then issues an SID to a qualified client. For a new client, the authentication server may open a new account and issue an SID thereafter. A valid SID typically

-6-

comprises a user identifier, an accessible domain, a key identifier, an expiration time such as date, the IP address of the user computer, and an unforgettable digital signature such as a cryptographic hash of all of the other
5 items in the SID encrypted with a secret key. The authentication server then forwards a new request consisting of the original URL appended by the SID to the client in a REDIRECT. The modified request formed by a new URL is automatically forwarded by the client browser to the
10 content server.

When the content server receives a URL request accompanied by an SID, it logs the URL with the SID and the user IP address in a transaction log and proceeds to validate the SID. When the SID is so validated, the
15 content server sends the requested document for display by the client's Web browser.

In the preferred embodiment, a valid SID allows the client to access all controlled files within a protection domain without requiring further authorization. A
20 protection domain is defined by the service provider and is a collection of controlled files of common protection within one or more servers.

When a client accesses a controlled Web page with a valid SID, the user viewing the page may want to traverse a
25 link to view another Web page. There are several possibilities. The user may traverse a link to another page in the same path. This is called a "relative link". A relative link may be made either within the same domain or to a different domain. The browser on the client
30 computer executes a relative link by rewriting the current URL to replace the old controlled page name with a new one. The new URL retains all portions of the old, including the SID, except for the new page name. If the relative link points to a page in the same protection domain, the SID
35 remains valid, and the request is honored. However, if the

-7-

relative link points to a controlled page in a different protection domain, the SID is no longer valid, and the client is automatically redirected to forward the rewritten URL to the authentication server to update the SID. The
5 updated or new SID provides access to the new domain if the user is qualified.

The user may also elect to traverse a link to a document in a different path. This is called an "absolute link". In generating a new absolute link, the SID is
10 overwritten by the browser. In the preferred embodiment, the content server, in each serving of a controlled Web page within the domain, filters the page to include the current SID in each absolute URL on the page. Hence, when the user elects to traverse an absolute link, the browser
15 is facilitated with an authenticated URL which is directed with its SID to a page in a different path. In another embodiment, the content server may forego the filtering procedure as above-described and redirect an absolute URL to the authentication server for an update.

20 An absolute link may also be directed to a controlled file in a different domain. Again, such a request is redirected to the authentication server for processing of a new SID. An absolute link directed to an uncontrolled file is accorded an immediate access.

25 In another embodiment, a server access control may be maintained by programming the client browser to store an SID or a similar tag for use in each URL call to that particular server. This embodiment, however, requires a special browser which can handle such communications and is
30 generally not suitable for the standard browser format common to the Web.

Another aspect of the invention is to monitor the frequency and duration of access to various pages both controlled and uncontrolled. A transaction log within a
35 content server keeps a history of each client access to a

-8-

page including the link sequence through which the page was
accessed. Additionally, the content server may count the
client requests exclusive of repeated requests from a
common client. Such records provide important marketing
5 feedback including user demand, access pattern, and
relationships between customer demographics and accessed
pages and access patterns.

The above and other features of the invention
including various novel details of construction and
10 combinations of parts will now be more particularly
described with reference to the accompanying drawings and
pointed out in the claims. It will be understood that the
particular devices and methods embodying the invention are
shown by way of illustration only and not as limitations of
15 the invention. The principles and features of this
invention may be employed in varied and numerous
embodiments without departing from the scope of the
invention.

Brief Description of the Drawings:

20 Figure 1 is a diagram illustrating the Internet
operation.

Figure 2A is a flowchart describing the preferred
method of Internet server access control and monitoring.

Figure 2B is a related flowchart describing the
25 details of the authentication process.

Figure 3 illustrates an example of a client-server
exchange session involving the access control and
monitoring method of the present invention.

Figure 4 is an example of a World Wide Web page.

30 Figure 5 is an example of an authorization form page.

Figure 6 is a diagram describing the details of the
translation of telephone numbers to URLs.

-9-

Detailed Description of the Invention:

Referring now to the drawings, Figure 1 is a graphical illustration of the Internet. The Internet 10 is a network of millions of interconnected computers 12 including systems owned by Internet providers 16 and information systems (BBS) 20 such as Compuserve or America Online. Individual or corporate users may establish connections to the Internet in several ways. A user on a home PC 14 may purchase an account through the Internet provider 16. Using a modem 22, the PC user can dial up the Internet provider to connect to a high speed modem 24 which, in turn, provides a full service connection to the Internet. A user 18 may also make a somewhat limited connection to the Internet through a BBS 20 that provides an Internet gateway connection to its customers.

Figure 2A is a flowchart detailing the preferred process of the present invention and Figure 4 illustrates a sample Web page displayed at a client by a browser. The page includes text 404 which includes underlined link text 412. The title bar 408 and URL bar 402 display the title and URL of the current web page, respectively. As shown in Figure 4, the title of the page is "Content Home Page" and the corresponding URL is "http://content.com/homepage". When a cursor 414 is positioned over link text 412b, the page which would be retrieved by clicking a mouse is typically identified in a status bar 406 which shows the URL for that link. In this example the status bar 406 shows that the URL for the pointed link 412b is directed to a page called "advertisement" in a commercial content server called "content". By clicking on the link text, the user causes the browser to generate a URL GET request at 100 in Figure 2A. The browser forwards the request to a content server 120, which processes the request by first determining whether the requested page is a controlled document 102. If the request is directed to an

-10-

uncontrolled page, as in "advertisement" page in this example, the content server records the URL and the IP address, to the extent it is available, in the transaction log 114. The content server then sends the requested page
5 to the browser 116 for display on the user computer 117.

If the request is directed to a controlled page, the content server determines whether the URL contains an SID 102. For example, a URL may be directed to a controlled page name "report", such as "http://content.com/report",
10 that requires an SID. If no SID is present, as in this example, the content server sends a "REDIRECT" response 122 to the browser 100 to redirect the user's initial request to an authentication server 200 to obtain a valid SID. The details of the authentication process are described in
15 Figure 2B and will be discussed later, but the result of the process is an SID provided from the authentication server to the client. In the above example, a modified URL appended with an SID may be: "http://content.com/[SID]/report". The preferred SID is a sixteen character ASCII
20 string that encodes 96 bits of SID data, 6 bits per character. It contains a 32-bit digital signature, a 16-bit expiration date with a granularity of one hour, a 2-bit key identifier used for key management, an 8-bit domain comprising a set of information files to which the current
25 SID authorizes access, and a 22-bit user identifier. The remaining bits are reserved for expansion. The digital signature is a cryptographic hash of the remaining items in the SID and the authorized IP address which are encrypted with a secret key which is shared by the authentication and
30 content servers.

If the initial GET URL contains a SID, the content server determines whether the request is directed to a page within the current domain 106. If the request having a SID is directed to a controlled page of a different domain, the

-11-

SID is no longer valid and, again, the user is redirected to the authentication server 122.

If the request is for a controlled page within the current domain, the content server proceeds to log the request URL, tagged with SID, and the user IP address in the transaction log 108. The content server then validates the SID 110. Such validation includes the following list of checks: (1) the SID's digital signature is compared against the digital signature computed from the remaining items in the SID and the user IP address using the secret key shared by the authentication and content servers; (2) the domain field of the SID is checked to verify that it is within the domain authorized; and (3) the EXP field of the SID is checked to verify that it is later than the current time.

If the validation passes, the content server searches the page to be forwarded for any absolute URL links contained therein 112, that is, any links directed to controlled documents in different content servers. The content server augments each absolute URL with the current SID to facilitate authenticated accesses across multiple content servers. The requested page as processed is then transmitted to the client browser for display 117. The user viewing the requested Web page may elect to traverse any link on that page to trigger the entire sequence again 100.

Figure 2B describes the details of the authentication process. The content server may redirect the client to an authentication server. The REDIRECT URL might be:

"http://auth.com/authenticate?domain=[domain]&URL=http://content.com/report". That URL requests authentication and specifies the domain and the initial URL. In response to the REDIRECT, the client browser automatically sends a GET request with the provided URL.

-12-

Whenever the content server redirects the client to the authentication server 200, the authentication server initiates the authorization process by validating that it is for an approved content server and determining the level of authentication required for the access requested 210. Depending on this level, the server may challenge the user 212 for credentials. If the request is for a low level document, the authentication may issue an appropriate SID immediately 228 and forego the credential check procedures. If the document requires credentials, the authentication server sends a "CHALLENGE" response which causes the client browser to prompt the user for credentials 214. A preferred credential query typically consists of a request for user name and password. If the user is unable to provide a password, the access is denied. The browser forms an authorization header 300 from the information provided, and resends a GET request to the authentication server using the last URL along with an authorization header. For example, a URL of such a GET request may be: "http://auth.com/authenticate?domain=[domain]&URL=http://content.com/report and the authorization header may be: "AUTHORIZE:[authorization]".

Upon receiving the GET request, the authentication server queries an account database 216 to determine whether the user is authorized 218 to access the requested document. A preferred account database may contain a user profile which includes information for identifying purposes, such as client IP address and password, as well as user demographic information, such as user age, home address, hobby, or occupation, for later use by the content server. If the user is authorized, an SID is generated 228 as previously described. If the user is not cleared for authorization, the authentication server checks to see if the user qualifies for a new account 220. If the user is not qualified to open a new account, a page denying access

-13-

222 is transmitted to the client browser 100. If the user is qualified, the new user is sent a form page such as illustrated in Figure 5 to initiate a real-time on-line registration 224. The form may, for example, require
5 personal information and credit references from the user. The browser is able to transmit the data entered by the user in the blanks 502 as a "POST" message to the authentication server. A POST message causes form contents to be sent to the server in a data body other than as part
10 of the URL. If the registration form filled out by the new user is valid 226, an appropriate SID is generated 228. If the registration is not valid, access is again denied 222.

An SID for an authorized user is appended ("tagged")
230 to the original URL directed to a controlled page on
15 the content server. The authentication server then transmits a REDIRECT response 232 based on the tagged URL to the client browser 100. The modified URL, such as "http://content.com/[SID]/report" is automatically forwarded to the content server 120.

20 Figure 3, illustrates a typical client-server exchange involving the access control and monitoring method of the present invention. In Step 1, the client 50 running a browser transmits a GET request through a network for an uncontrolled page (UCP). For example, the user may request
25 an advertisement page by transmitting a URL "http://content.com/advertisement", where "content.com" is the server name and "advertisement" is the uncontrolled page name. In Step 2, the content server 52 processes the GET request and transmits the requested page, "advertisement".
30 The content server also logs the GET request in the transaction database 56 by recording the URL, the client IP address, and the current time.

In Step 3, the user on the client machine may elect to traverse a link in the advertisement page directed to a
35 controlled page (CP). For example, the advertisement page

-14-

may contain a link to a controlled page called "report". Selecting this link causes the client browser 50 to forward a GET request through a URL which is associated with the report file "http://content.com/report". The content server 52 determines that the request is to a controlled page and that the URL does not contain an SID. In Step 4, the content server transmits a REDIRECT response to the client, and, in Step 5, the browser automatically sends the REDIRECT URL to the authentication server 54. The REDIRECT URL sent to the authentication server may contain the following string:

```
"http://auth.com/authenticate?domain=[domain]&URL=http://content.com/report"
```

The authentication server processes the REDIRECT and determines whether user credentials (CRED) are needed for authorization. In Step 6, the authentication server transmits a "CHALLENGE" response to the client. As previously described, typical credentials consist of user name and password. An authorization header based on the credential information is then forwarded by the client browser to the authentication server. For example, a GET URL having such an authorization header is:

```
"http://autho.com/authenticate?domain=[domain]&URL=http://content.com/report and the authorization header may be:"AUTHORIZE:[authorization]". The authentication server processes the GET request by checking the Account Database 58. If a valid account exists for the user, an SID is issued which authorizes access to the controlled page "report" and all the other pages within the domain.
```

As previously described, the preferred SID comprises a compact ASCII string that encodes a user identifier, the current domain, a key identifier, an expiration time, the client IP address, and an unforgeable digital signature. In Step 8, the authentication server redirects the client to the tagged URL, "http://content.com/[SID]/report", to

-15-

the client. In Step 9, the tagged URL is automatically forwarded by the browser as a GET request to the content server. The content server logs the GET request in the Transaction database 56 by recording the tagged URL, the client IP address, and the current time. In Step 10, the content server, upon validating the SID, transmits the requested controlled page "report" for display on the client browser.

According to one aspect of the present invention, the content server periodically evaluates the record contained in the transaction log 56 to determine the frequency and duration of accesses to the associated content server. The server counts requests to particular pages exclusive of repeated requests from a common client in order to determine the merits of the information on different pages for ratings purposes. By excluding repeated calls, the system avoids distortions by users attempting to "stuff the ballot box." In one embodiment, the time intervals between repeated requests by a common client are measured to exclude those requests falling within a defined period of time.

Additionally, the server may, at any given time, track access history within a client-server session. Such a history profile informs the service provider about link transversal frequencies and link paths followed by users. This profile is produced by filtering transaction logs from one or more servers to select only transactions involving a particular user ID (UID). Two subsequent entries, A and B, corresponding to requests from a given user in these logs represent a link traversal from document A to document B made by the user in question. This information may be used to identify the most popular links to a specific page and to suggest where to insert new links to provide more direct access. In another embodiment, the access history is evaluated to determine traversed links leading to a

-16-

purchase of a product made within commercial pages. This information may be used, for example, to charge for advertising based on the number of link traversals from an advertising page to a product page or based on the count of purchases resulting from a path including the advertisement. In this embodiment, the server can gauge the effectiveness of advertising by measuring the number of sales that resulted from a particular page, link, or path of links. The system can be configured to charge the merchant for an advertising page based on the number of sales that resulted from that page.

According to another aspect of the present invention, a secondary server, such as the authentication server 200 in Figure 2B, may access a prearranged user profile from the account database 216 and include information based on such a profile in the user identifier field of the SID. In a preferred embodiment, the content server may use such an SID to customize user requested pages to include personalized content based on the user identifier field of the SID.

In another aspect of the invention, the user may gain access to domain of servers containing journals or publications through a subscription. In such a situation, the user may purchase the subscription in advance to gain access to on-line documents through the Internet. The user gains access to a subscribed document over the Internet through the authorization procedure as described above where an authorization indicator is preferably embedded in a session identifier. In another embodiment, rather than relying on a prepaid subscription, a user may be charged and billed each time he or she accesses a particular document through the Internet. In that case, authorization may not be required so long as the user is fully identified in order to be charged for the service. The user

-17-

identification is most appropriately embedded in the session identifier described above.

In another aspect of the invention, facilities are provided to allow users to utilize conventional telephone numbers or other identifiers to access merchant services. These merchant services can optionally be protected using SIDs. In a preferred embodiment, as shown in Figure 6, a Web browser client 601 provides a "dial" command to accept a telephone number from a user, as by clicking on a "dial" icon and inputting the telephone number through the keyboard. The browser then constructs a URL of the form "http://directory.net/NUMBER", where NUMBER is the telephone number or other identifier specified by the user. The browser then performs a GET of the document specified by this URL, and contacts directory server 602, sending the NUMBER requested in Message 1.

In another embodiment, implemented with a conventional browser, client 601 uses a form page provided by directory server 601 that prompts for a telephone number or other identifier in place of a "dial" command, and Message 1 is a POST message to a URL specified by this form page.

Once NUMBER is received by directory server 601, the directory server uses database 604 to translate the NUMBER to a target URL that describes the merchant server and document that implements the service corresponding to NUMBER. This translation can ignore the punctuation of the number, therefore embedded parenthesis or dashes are not significant.

In another embodiment an identifier other than a number may be provided. For example, a user may enter a company name or product name without exact spelling. In such a case a "soundex" or other phonetic mapping can be used to permit words that sound alike to map to the same target URL. Multiple identifiers can also be used, such as

-18-

a telephone number in conjunction with a product name or extension.

In Message 2, Directory server 602 sends a REDIRECT to client 601, specifying the target URL for NUMBER as
5 computed from database 604. The client browser 601 then automatically sends Message 3 to GET the contents of this URL. Merchant server 603 returns this information in Message 4. The server 602 might have returned a Web page to the client to provide an appropriate link to the
10 required document. However, because server 602 makes a translation to a final URL and sends a REDIRECT rather than a page to client 601, the document of message 4 is obtained without any user action beyond the initial dial input.

The Target URL contained in Message 3 can be an
15 ordinary URL to an uncontrolled page, or it can be a URL that describes a controlled page. If the Target URL describes a controlled page then authentication is performed as previously described. The Target URL can also describe a URL that includes an SID that provides a
20 preauthorized means of accessing a controlled page.

Among benefits of the "dial" command and its implementation is an improved way of accessing the Internet that is compatible with conventional telephone numbers and other identifiers. Merchants do not need to alter their
25 print or television advertising to provide an Internet specific form of contact information, and users do not need to learn about URLs.

In the approach a single merchant server can provide multiple services that correspond to different external
30 "telephone numbers" or other identifiers. For example, if users dial the "flight arrival" number they could be directed to the URL for the arrival page, while, if they dial the "reservations" number, they would be directed to the URL for the reservations page. A "priority gold"
35 number could be directed to a controlled page URL that

-19-

would first authenticate the user as belonging to the gold users group, and then would provide access to the "priority gold" page. An unpublished "ambassador" number could be directed to a tagged URL that permits access to the

5 "priority gold" page without user authentication.

This invention has particular application to network sales systems such as presented in U.S. Patent Application Serial No. 08/328,133, filed October 24, 1994, by Payne et al. which is incorporated herein by reference.

10 Equivalents:

Those skilled in the art will know, or be able to ascertain using no more than routine experimentation, many equivalents to the specific embodiments or the invention described herein. These and all other equivalents are

15 intended to be encompassed by the following claims.

-20-

Appendix

```

/* TclIdSid
 *   Scans an ascii line and finds an ascii SID. (no validation though)
 * Inputs:
 *   lineoftext
 * Returns:
 *   ascii bin_sid, if a sid is found it is returned.
 *
 */

int TclIdSid(ClientData dummy, Tcl_Interp *interp,
             int argc, char **argv)
{
    char *sidp, *cp;

    interp->result[0] = 0;

    if (argc != 2)
    {
        interp->result = "wrong # args";
        return TCL_ERROR;
    }
    sidp = (char *) strstr(argv[1], "@@");
    if (sidp == NULL) return TCL_OK;
    cp = (char *) strstr(sidp+1, "/");
    if ((cp == NULL) && (strlen(sidp) != 19)) return TCL_OK;
    if ((cp - sidp) != 19) return TCL_OK;
    strncpy(interp->result, sidp, 19);
    interp->result[19] = 0;
    return TCL_OK;
}

/*
 * Register commands with interpreter.
 */
int SidSupInit(Tcl_Interp *interp)
{
    Tcl_CreateCommand(interp, "packsid", TclPackSid, NULL, NULL);
    Tcl_CreateCommand(interp, "unpacksid", TclUnpackSid, NULL, NULL);
    Tcl_CreateCommand(interp, "unpacksidnovalidate", TclUnpackSidNoValidate,
    NULL,
    Tcl_CreateCommand(interp, "issid", TclIdSid, NULL, NULL);
    return TCL_OK;
}

```

-21-

```
/*
-----
*
* compute_ihash --
*
* Compute the MD5 hash for the specified string, returning the hash as
* a 32b xor of the 4 hash longwords.
*
* Results:
*     hash int.
*
* Side effects:
*     None.
-----
*/
int compute_ihash(char *str)
{
    MD5_CTX md5;
    unsigned char hash[16];
    unsigned int *p1;
    unsigned int hashi = 0;

    MD5Init(&md5);
    MD5Update(&md5, str, strlen(str));
    MD5Final(hash, &md5);
    p1 = (unsigned int *) hash;

    hashi = *p1++;
    hashi ^= *p1++;
    hashi ^= *p1++;
    hashi ^= *p1++;
    return hashi;
}

/*
* ticket.c --
*
*     Commands for TICKET.
*
* Copyright 1995 by Open Market, Inc.
* All rights reserved.
*
* This file contains proprietary and confidential information and
* remains the unpublished property of Open Market, Inc. Use,
* disclosure, or reproduction is prohibited except as permitted by
* express written license agreement with Open Market, Inc.
*

```

-22-

```

* Steve Morris
* morris@OpenMarket.com
*
* Created: Wed Mar 1 1995
* $Source: /omi/proj/master/omhttpd/Attic/ticket.c,v $
*
*/

#if !defined(lint)
static const char rcsid[]="$Header: /omi/proj/master/omhttpd/Attic/ticket.c,v
2.
#endif /*not lint*/

#include <stdio.h>
#include <sys/utsname.h>
#include "httpd.h"
#include "md5.h"
#include "ticket.h"

static TICKET_Server TicketServerData;

/*
* This file implements all the ticket/sid related functions for the server.
*
* The region commands RequireSID and xxxxx can be used to limit
* access to groups of files based on the authentication of the requestor.
* The two commands are very similar, and only differ in the method used to
* present the authentication data (via the URL) and in handling of the
* failing access case. For failing TICKET's, a "not authorized" message is
* generated. For failing (or absent) SID's, a REDIRECT (either local or via
* CGI script) is performed to forward the request to an authentication
server.
*
* RequireSID domain1 [domain2 ... domainn]
*
* This command denies access unless the specified properties are
* true of the request. Only one RequireSID or xxxxx command can
* be used for a given region, though it may specify multiple domains.
*
*/

static int ProcessRequires(ClientData clientData, Tcl_Interp *interp,
                           int argc, char **argv, int flavor);
static int DomainNameCmd(ClientData clientData, Tcl_Interp *interp,
                          int argc, char **argv);
static int GetDomain(char *domname, int dflt);

```

-23-

```

static char *GetAsciiDomain(char *domname, char *dflt);
static int  computer_ihash(char *str);
static char *computerHash(char *str);
static char *GetSecret(int kid);
static int  GetKidByKeyID(char *keyID);
static char *CreateSid(HTTP_Request *reqPtr, int dom, int uid, int kid,
                       int exp, int uctx);
static void freeTicketReqData(void *dataPtr);
static void DumpStatus(HTTP_Request *reqPtr);
static void TICKET_DebugHooks(ClientData clientData, char *suffix,
                              HTTP_Request *reqPtr);
static int ParseSid(HTTP_Request *reqPtr);
static int ParseTicket(HTTP_Request *reqPtr);
static char *fieldParse(char *str, char sep, char **endptr);
void TICKET_ConfigCheck();
void DumpRusage(HTTP_Request *reqPtr);

/*
*-----
*
* TICKET_RequireSidCmd --
*
*      Checks that the requested URL is authorized via SID to access this
*      region. If the access is not authorized and we do not have a "remote"
*      authentication server" registered, then an "unauthroized message"
*      is returned.  If a "remote authentication server" has been
*      declared, we REDIRECT to that server, passing the requested URL and
*      required domain's as arguments.
*
* Results:
*      Normal Tcl result, or a REDIRECT request.
*
* Side effects:
*      Either an "unauthorized access" message or a REDIRECT in case of
error.
*
*-----
*/
static int TICKET_RequireSidCmd(ClientData clientData, Tcl_Interp *interp,
                              int argc, char **argv)
{
    if (TicketGlobalData(EnableSidEater)) return TCL_OK;
    return(ProcessRequires(clientData, interp,argc, argv, ticketSid));
}

/*
*-----
*

```

-24-

```

* ProcessRequired --
*
* Checks that the requested URL is authorized to access this
* region. The error cases are treated differently for SID v.s. TICKET.
* For Ticket's, an unauthorized access generates a returned error
message.
* For SID's, we first look to see if we are operating in "local
authentica
* mode", if we are, we generate a new SID, into the URL and re-process
the
* If not in "local" mode, we look for the presence of a
remoteauthenticati
* server, if we have one declared (in the conf file) we REDIRECT to it
pas
* the FULL url and a list of domains that would have been legal. If
the
* authentication server was not found we return an error message.
*
* Results:
* Normal Tcl result, a local reprocess command, or a REDIRECT request.
*
* Side effects:
* Either an "unauthorized access" message or a REDIRECT in case of
error.
*
*-----
*/
static int ProcessRequires(ClientData clientData, Tcl_Interp *interp,
                           int argc, char **argv, int flavor)
{
    HTTP_Request *reqPtr = (HTTP_Reqeust *) client Data;
    HTTP_Server *serverPtr;
    TICKET_Request *ticketPtr;
    DString targetUrl;
    DString escapeUrl;
    int i, required_dom;
    int firstLegalDom = -1;
    char *NewSid, *cp;

    DStringInit(&targetUrl);
    DStringInit(&escapeUrl);

    /* fetch the server private and ticket specific extension data */
    serverPtr = reqPtr->serverPtr;
    ticketPtr = (TICKET_Request *) HT_GetReqExtData(reqPtr,
TicketServerData.tic
    ASSERT (ticketPtr != NULL);

```

-25-

```

/* compare the requesting SID/Ticket<DOM> to authorized list of domains */
/* a match OR any valid domain and a required domain of TicketFreeArea is
su
for (i = 1; i < argc; i++)
{
    required_dom = GetDomain(argv[i] -1);
    if (required_dom != -1)
    {
        if (firstLegalDom == -1) firstLegalDom = required_dom;
        if ( (ticketPtr->sidDom == required_dom) ||
            (ticketPtr->valid && (ticketPtr->sidDom != -1) &&
              (required_dom == TicketGlobalData(FreeArea))) ||
            ((ticketPtr->ticketDom == required_dom) &&
              (time(0) <= ticketPtr->ticketExp) &&
              ((DStringLength(&ticketPtr->ticketIP) == 0) ||
               (strcmp(DStringValue(&ticketPtr->ticketIP), DStringValue(&reqPtr-
>r
                )
                {
                    DStringFree(&targetUrl);
                    DStringFree(&escapeUrl);
                    return TCL_OK;
                }
            }
        }

/* count the number of domain crossing that caused re-auth */
if ((flavor == ticketSid) && (ticketPtr->sidDom) != -1) IncTicketCounter(Cou

/* authorization failed, if this was a sid url, and local auth is enabled */
/* or this was an access to the free area */
/* insert a new sid in the url, and REDIRECT back to the client 8?
if (TicketGlobalData(EnableLocalAuth) ||
    ((firstLegalDom == TicketGlobalData(FreeArea))
     && (flavor == ticketSid) && (firstLegalDom != -1)))
{
    if ((DStringLength(&reqPtr->url) != 0) &&
        (DStringValue(&reqPtr->url)[0] != '/'))
    {
        HTTP_Error(reqPtr, NOT_FOUND, "access denied due to poorly formed url");
        DStringFree(&targetUrl);
        DStringFree(&escapeUrl);
        if (!ticketPtr->valid)
            DStringFree(&ticketPtr->sid);
        return TCL_RETURN;
    }
}
NewSid = CreateSid(reqPtr,

```

-26-

```

        firstLegalDom, ticketPtr->uid,
        TicketGlobalData(CurrentSecret), TicketGlobalData(LocalAuthExp)
        ticketPtr->uctx);
    DStringFree(&ticketPtr->sid);
    DStringAppend(&ticketPtr->sid, NewSid, -1);
    ComposeURL(reqPtr, DStringValue(&reqPtr->url), &targetUrl);
    IncTicketCounter(CountLocal Redirects);
    HTTP_Error*reqPtr, REDIRECT, DStringValue(&targetUrl));
    DStringFree(&targetUrl);
    DStringFree(&escapeUrl);
    if (!ticketPtr->valid)
        DStringFree(&ticketPtr->sid);
    return TCL_RETURN;
}

/* authorization failed, build the REDIRECT URL arg's. */
/* If present, REDIRECT to authentication server */
if ((DStringLength(&TicketGlobalData(AuthServer)) != 0) && (flavor == ticket
{
    if ((DStringLength(&reqPtr->url) != 0) &&
        (DStringValue(&reqPtr->url) [0] != '/'))
        {
            HTTP_Error(reqPtr, NOT_FOUND, "access denied due to poorly formed url");
            DStringFree(&targetUrl);
            DStringFree(&escapeUrl);
            if (!ticketPtr->valid)
                DStringFree(&ticketPtr->sid);

            return TCL_RETURN ;
        }
    DStringAppend(&targetUrl, DStringValue(&TicketGlobalData(AuthServer)), -1)
    DStringAppend(&targetUrl, "?url=", -1);
    ComposeURL(reqPtr, DStringValue(&reqPtr->url), &escapeUrl)
    EscapeUrl(&escapeUrl);
    DStringAppend(&targetUrl, DStringValue(&escapeUrl), -1);
    DStringAppend(&targetUrl, "&domain=", -1);
    DStringTrunc(&escapeUrl, 0);
    DStringAppend(&escapeUrl, "{=", -1);
    for (i=1; i < argc; i++)
        {
            cp = GetAsciiDomain*argv[i], NULL);
            if (cp != NULL)
                {
                    DStringAppend(&escapeUrl, cp, -1);
                    DStringAppend(&escapeUrl, " ", -1);
                }
        }
}

```

-27-

```

DStringAppend(&escapeUrl, "}", -1);
EscapeUrl(&escapeUrl);
DStringAppend(&targetUrl, DStringValue(&escapeUrl), -1);
DStringFree(&escapeUrl);
HTTP_Error(reqPtr, REDIRECT, DStringValue(&targetUrl));
IncTicketCounter(CountRemoteRedirects);
DStringFree(&targetUrl);
if (!ticketPtr->valid)
    DStringFree(&ticketPtr->sid);
return TCL_RETURN;
}

/* authorization failed, if this is a ticket access, decode the */
/* reason and handl via a redirect to a handler, or punt a      */
/* no access message */
if ((flavor == ticketTicket) && (firstLegalDom != -1) && (ticketPtr->ticketD
{
    /* check For IP address restrictions */
    if ((DStringLength(&ticketPtr->ticket IP) != 0) &&
        (DStringLength(&TicketGlobalData(TicketAdrHandler)) != 0) &&
        (strcmp(DStringValue(&ticketPtr->ticketIP), DStringValue(&reqPtr->remo
    {
        DStringAppend(&targetUrl, DStringValue(&TicketGlobalData(TicketAdrHandle
        DStringAppend(&targetUrl, DStringValue(&ticketPtr->fields), -1);
        DStringAppend(&targetUrl, "&url=", -1);
        DStringAppend(&targetUrl, DStringValue(&reqPtr->url), -1);
        IncTicketCounter(CountTicketAddr);
        HTTP_Error(reqPtr, REDIRECT, DStringValue(&targetUrl));
        DStringFree(&targetUrl);
        return TCL_RETURN;
    }

/* check for expired tickets */
if (time(0) > ticketPtr->ticketExp)
{
    DStringAppend(&targetUrl, DStringValue(&TicketGlobalData(TicketExpHandle
    DStringAppend(&targetUrl, DStringValue(&ticketPtr->fields), -1);
    DStringAppend(&targetUrl, "&url=", -1);
    DStringAppend(&targetUrl, DStringValue(&reqPtr->url), -1);
    IncTicketCounter(CountExpiredTicket);/*

HTTP_Error(reqPtr, REDIRECT, DStringValue(&targetUrl));
DStringFree(&targetUrl);
return TCL_RETURN;
}
}

```

-28-

```

/* no handler, punt a message */
HTTP_Error(reqPtr, FORBIDDEN, "access denied by Require ticket/sid region
co
IncTicketCounter(CountNoRedirects);
if (!ticketPtr->valid)
DStringFree(&ticketPtr->sid);
DStringFree(&targetUrl);
DStringFree(&escapeUrl);
return TCL_RETURN;
}

/*
-----
*
* Get(Ascii)Domain --
* These routine performs an ascii to binary domain name lookup,
* indexed by 'key') from the server's domain name catalog. Name/number
* pair's are loaded into the catalog at configuration time with the
* with the "Domain" configuration command. The Ascii version returns
* a pointer to a character string that represents the domain number.
* The non Ascii version returns an integer representing the domain number.
*
* Results:
* Integer value of domain. If no domain is available, returns deflt.
*
* Side effects:
* None.
*
-----
*/
static int GetDomain (char *domname, int deflt)
{
    HashEntry *entryPtr;
    DString DomName;

    DStringInit(&DomName);
    DStringAppend(&DomName, domname, -1);
    strtolower(DStringValue(&DomName));

    entryPtr = FindHashEntry(&TicketServerData.Domains,
DStringValue(&DomName));
    DStringFree(&DomName);
    if (entryPtr == NULL) return deflt;

```

-29-

```

    return (int) GetHashValue(entryPtr);
}
static char * GetAsciiDomain(char *domname, char *deflt)
{
    HashEntry *entryPtr;
    static char buffer[64];
    DString DomName;

    DStringInit (&DomName);
    DStringAppend(DomName, domname, -1);
    strtolower(DStringValue(&DomName));

    entryPtr = FindHashEntry(&TicketServerData.Domains,
DStringValue(&DomName));
    DStringFree(&DomName);
    if (entryPtr == NULL) return deflt;
    sprintf(buffer, "%d", (int) GetHashValue(entryPtr));
    return buffer;
}
/*
*-----
*
* TICKET_InsertLocalSid --
*
* Given a URL, inspect it to see if it refers to the local server/port
* if it does, and it does not already contain a SID, insert one if
* the current request included one. Note, for port 80 access we look
* for a match with and without the port specifier.
*
* Results:
* None.
*
* Side effects:
*   A SID may be inserted into the URL.
*
*-----
*/
void TICKET_InsertLocalSid(HTTP_Request *reqPtr, DString *result)
{
    HTTP_Server *serverPtr;
    TICKET_Request *ticketPtr;
    char tmp[32];
    DString pattern1;

```

-30-

```

DString pattern2;
DString tmp_url;
DString *hitPattern = NULL;

ticketPtr = (TICKET_Request *) HT_GetReqExtData(reqPtr,
TicketServerData.tic
if (ticketPtr == NULL) return;
serverPtr = reqPtr->serverPtr;

DStringInit(&pattern1);
DStringInit(&pattern2);
DStringInit(&tmp_url);

DStringAppend(&pattern1, "http://", -1);
DStringAppend(&pattern1, DStringValue(&serverPtr->serverName), -1);
DStringAppend(&pattern2, DStringValue (&pattern1), -1);
sprintf(tmp, ":%d", serverPtr->server_port);
DStringAppend(&pattern1, tmp, -1);

if ((DStringLength(result) >= DStringLength(&pattern1)) &&
    (strncasecmp(DStringValue(&pattern1), DStringValue(result),
DStringLengt hitPattern = &pattern1;
else
if ((serverPTR-->server_port == 80) &&
    (DStringLength(result) >= DStringLength(&pattern2)) &&
    (strncasecmp(DStringValue(&pattern2), DStringValue(result),
DStringLength hitPattern + &pattern2;

if (hitPattern != NULL)
{
DStringAppend(&tmp_url, DStringValue(hitPattern), -1;
DStringAppend(tmp_url, DStringValue(&ticketPtr->sid), -1);
DStringAppend(&tmp_url, &DStringValue(result)
[DStringLength(hitPattern)],
DStringFree(result);

DStringAppend(result, DStringValue(&tmp_url), -1);
DStringFree(&tmp_url);
}

DStringFree(&pattern1);
DStringFree(&pattern2);
DStringFree(&tmp_url);
}
/*

```

-31-

```

*-----
*
* CreateSid --
*
  This routine takes the passed arguments and creates a sid.
*
* Results:
* A sid.
*
* Side effects:
*
*-----
*/
char * CreateSid(HTTP_Request *reqPtr, int dom, int uid, int kid, int exp,
int uctx)
{
  int bsid[3] = {0,0,0};
  char temp_str[512];
  DString hash;
  int act_hash;
  static char sid[64];
  unsigned int expire_time;
  char *secret;
  char *hashP;
  char *cp;
  unsigned char *ecp;
  unsigned int eda;
  int endian = 1;

  DStringInit(&hash);
  expire_time =time(0)+ exp;

  put_sid(dom_lw,      dom_pos,    dom_mask,   dom);
  put_sid(uid_lw,     uid_pos,    uid_mask,   uid);
  put_sid(kid_lw,    kid_pos,    kid_mask,   kid);
  put_sid(exp_lw,    esp_pos,    exp_mask,
(expire_time>>exp_shft_amt))
  put_sid(uctx_lw,   uctx_pos,   uctx_mask,  uctx);
  put_sid(rev_lw,   rev_pos,    rev_mask,   sid_rev_zero);

  secret = GetSecret(kid);
  ASSERT (secret != NULL);
  DStringAppend(&hash, secret, -1);

```

-32-

```

DStringAppend(&hash, DStringValue(&reqPtr->remoteAddr), -1;
sprintf(temp_str, "%08x%08x", bsid[2],bsid[1]);
DStringAppend(&hash, temp_str, -1);
/* format of the hash string is %s%s%08x%08x",
secret,ip_addr,bsid[2[,bsid[1
hashP = DStringValue (&hash);
act_hash = compute_ihash(hashP);
while (*hashP != 0) *hashP++ = 0;
DStringFree(&hash);
/* fix_endian(&act_hash, ecp, eda); */

.put_sid(sig_lw, sig_pos, sig_mask, act_hash)

/* fix_endian(&bsid[0], ecp, eda); */
fix_endian(&bsid[1], ecp, eda);
fix_endian*&bsid[2], ecp, eda);

#if (1 == 0
DumpSid());
#endif

cp = radix64encode_noslash((char *) bsid, 12);
strcpy(sid, SID_prefix);
strcat(sid, cp);
free(cp);
return(sid);
}

/*
-----
*
* compute_hash --
*
* Compute the MD5 hash for the specified string, returning the hash as
* a 32 b xor of the 4 hash longwords.
*
* Results:
hash int.
*
* Side effects:
None.
-----

```

-33-

```

*/
static int compute_ihash(char *str)
{
    MD5_CTX md5;
    unsigned char hash[16];
    unsigned int *pl;
    unsigned int hashi = 0;

    MDInit(&md5);
    MDUpdate(&md5, (unsigned char *) str, strlen(str));
    MDFinal(hash, &md5);
    pl = (unsigned int *) hash;

    hashi = *pl++;
    hashi ^= *pl++;
    hashi ^= *pl++;
    hashi ^= *pl++;
    return hashi;
}

/*
-----
*
* computeHash --
*
* Compute the MD5 hash for the specified string, returning the hash as
* a 32-character hex string.
*
* Results:
* Pointer to static hash string.
*
* Side Effects:
* None.
-----
*/
static char *computeHash(char *str)
{
    int i;
    MD5_CTX md5;
    unsigned char hash[16];
    static char hashstr[33];
    char *q;

```

-34-

```

MD5Init(&md5);
MD5Update(&md5, (unsigned char *) str, strlen(str));
MD5Final(hash, &md5);
q = hashstr;
for(i=0; i<16; i++ {
    sprintf(q, "%02x", hash[i]);
    q += 2;
}
*q = '\0';
return hashstr;
}

/*
-----
*
* TICKET_ParseTicket --
* Called by dorequest, before any region commands or mount handlers
* have run. We parse and handle incoming sid's and tickets.
*
* Results:
* None.
*
* Side effects:
*
-----

*/
int TICKET_ParseTicket(HTTP_Request *reqPtr)
{
    int status = HT_OK;

    IncTicketCounter(CountTotalUrl);

    status = ParseSid(reqPtr);
    if (TicketGlobalData(EnableTicket) && (status == HT_OK)) status =
ParseTicke return status;
}

/*
-----
*
* ParseSid --
*

```

-35-

* Called by TICKET_ParseTicket, before any region commands or mount handle
 * have run. We parse and handle incoming sid's.

*

* Results:

* None.

*

* Side effects:

*

*-----
 */

```
int ParseSid(HTTP_Request *reqPtr)
```

```
{
  TICKET_Request *ticketPtr;
  HTTP_Server *serverPtr;
  DString hash;
  Int i;
  char *cp, *cpl;
  int *bsid=NULL, act_hash;
  unsigned int cur_tim, tdif, exp_tim;
  char *secret;
  char temp_str[512];
  char *hashP;
  int sid_ok = 0;
  unsigned char *ecp;
  unsigned int eda;
  int endian = 1;
  int ip1,ip2,ip3,ip4;
```

```
/* fetch the server private ticket extension data */
```

```
/* note that this sets up a default ticket block for both SID's and Ticket a  

serverPtr = reqPtr->serverPtr;
```

```
ticketPtr = (TICKET_Request *) HT_GetReqExtData (reqPtr, TicketServerData.tic  

ASSERT (ticketPtr == NULL);
```

```
ticketPtr = (TICKET_Request *) Malloc(sizeof(TICKET_Request));
```

```
HT_AddReqExtData(reqPtr, TicketServerData.ticketExtensionId, ticketPtr, free  

DStringInit(&ticketPtr->rawUrl);
```

```
DStringInit(&ticketPtr->sid);
```

```
DStringInit(&ticketPtr->fields);
```

```
DStringInit(&TicketPtr->signature);
```

```
DStringInit(&TicketPtr->ticketIP);
```

```
ticketPtr->valid      = 0;
```

```
ticketPtr->sidDom     = -1;
```

```
ticketPtr->ticketDom  = -1;
```

```
ticketPtr->ticketExp  = -1;
```

```
ticketPtr->uid        = 0
```

-36-

```

TicketPtr->uctx      = 0;
sscanf(DStringValue(&reqPtr->remoteAddr), "%d.%d.%d.%d", &ip1, &ip2, &ip3, &
ticketPtr->uid = (((ip1+ip2)<<24) | ((ip3+ip4)<<16) | (rand() & 0xFFFF));
ticketPtr->uctx = 1;
/* we are done if sids are not enabled, or this url does not have a sid */
if (!(TicketGlobalData(EnableSid))) return HT_OK;
cp1 = DStringValue(&reqPtr->url;
if (strstr(cp1, SID prefix) != cp1)
    return HT_OK;
if (strlen(cp1) == sidLength)
    {
    DStringAppend(&reqPtr->url, "/", -1);
    DStringAppend(&reqPtr->path, "/", -1);
    cp1 = DStringValue(&reqPtr->url);
    }
cp = strchr(cp1+sizeof(SID_prefix), '/');
if ((cp - cp1) != sidLength)
    return HT_OK;
IncTicketCounter(CountSidUrl);

DStringInit(&hash);

/* if sid eater is enabled, rewrite the url without the sid, and reprocess t
if (TicketGlobalDat(EnableSidEater))
    {
    DStringAppend(&hash, DStringValue(&reqPtr->url), -1);
    DStringFree(reqPtr->url);
    DStringAppend(&reqPtr->url, DStringValue(&hash)&hash)+sidLength, -1);
    DStringTrunc(&hash, 0);
    DStringAppend(&hash, DStringValue(&reqPtr->path), -1);
    DStringFree(&reqPtr->path);
    DStringAppend(&reqPtr->path, DStringValue(&hash)+sidLength, -1);
    DStringFree(&hash);
    IncTicketCounter(CountDiscardedSidUrl);
    return HT_OK;
    }

DStringAppend(&ticketPtr->sid, DStringValue(&reqPtr->url), sidLength);

/* first convert the SID back to binary*/
i = DStringLength(&ticketPtr->sid)-3;
bsid = (int *) radix64decode_noslash(DStringValue(&ticketPtr->sid)+3, i, &i)
if ((bsid == NULL) || (i !=12)) goto rtn_exit;

fix_endian(&bsid[0], ecp, eda);
fix_endian(&bsid[1], ecp, eda);
fix_endian(&bsid[2], ecp, eda);

```

-37-

```

/* check the SID version field */
if (get_sid(rev_lw,rev_pos,rev_mask) != sid_rev_zero) goto sid_bad;
if (get_sid(rsrv1_lw,rsrv1_pos,rsrv1_mask) != 0) goto sid_bad;
if (get_sid(rsrv2_lw,rsrv2_pos,rsrv2_mask) != 0) goto sid_bad;

/* Get a pointer to the secret */
secret = GetSecret(get_sid(kid_lw,kid_pos,kid_mask));
if (secret == NULL) goto sid_bad;

/* hash the sid and check the signature*/
DStringAppend(&hash, secret, -1);

DStringAppend(&hash, DStringValue(&reqPtr->remoteAddr), -1);
sprintf(temp_str, "%08x%08x", bsid[2],bsid[1]);
dstringAppend(&hash, temp_str, -1);
/* format of the hash string is %s%s%08x%08x", secret,ip_addr,bsid[2],bsid[1

hashP = DStringValue(&hash);
act_hash = compute_ihash(hashP);
while (*hashP != 0) *hashP== 0;
fix_endian(&act_hash, ecp, eda);
if (act_hash != get_sid(sig_lw,sig_pos,sig_mask)) goto sid_bad;

/* is is ok, may be expired, but good enough to id user */
ticketPtr->uid = get_sid(uid_llw,uid_pos,uid_mask);
ticketPtr->uctx = get_sid(uctx_lw,uctx_pos,uctx_mask);

/* do the SID expiration processing*/
cur_tim = (time(0)>>exp_shft_amt) & exp_mask;
expp_tim = get_sid(exp_lw,exp_pos,exp_mask);
tdif = (exp_tim - cur_tim) & 0xffff;
if (tdif > 0X7fff)
{
    IncTicketCounter(countExpSid);
    goto sid_exp;
}

/* sid is fine, save the sid state, update the url's */
ticketPtr->sidDom = get_sid(dom_lw,dom_pos,dom_mask);
ticketPtr->valid = 1;
sid_ok = 1;
IncTicketCounter(CountValidSid);

sid_bad:
    if (!(sid_ok)) IncTicketCounter(CountInvalidSid);
sid_exp:
    DStringAppend(&ticketPtr->rawUrl, DStringValue(&reqPtr->path), -1);

```

-38-

```

DStringTrunc(&reqPtr->path, 0);
DStringAppend(&reqPtr->path, DStringValue(&ticketPtr->rawUrl)+sidLength, -1)

DStringTrunc(&ticketPtr->rawUrl, 0);
DStringAppend(&ticketPtr->rawUrl, DStringValue(&reqPtr->url), -1);
DStringTrunc(&reqPtr->url, 0);
DStringAppend(&reqPtr->url, DStringValue(&ticketPtr->rawUrl)+sidLength, -1);

rtn_exit:
    DStringFree(&hash);
    if (bsid != NULL) free(bsid);
    return HT_OK;
}

/*
-----
*
* freeTicketReqData
*
* This routine frees the storage used by ticket specific request
* data.
*
* Results:
* None.
*
* Side effects:
* Memory freed.
*
-----
*/

static void freeTicketReqData(void *dataPtr)
{
    TICKET_Request *ticketPtr = dataPtr;
    DStringFree(&ticketPtr->rawUrl);
    DStringFree(&ticketPtr->sid);
    DStringFree(&ticketPtr->fields);
    DStringFree(&ticketPtr->signature);
    DStringFree(&ticketPtr->ticketIP);
    free(ticketPtr);
}

/*
-----
*
* GetSecret --
*
* Given a binary keyID, returns an ascii secret from the

```

-39-

```

* secrets store.
* for untranslatable names, return NULL.
*
* Results:
* "I've got a secret, now you do too"
*
* Side effects:
*
*
*-----
*/

```

```

char *GetSecret(int kid)
{
    HashEntry *entryPtr;

    entryPtr = FindHashEntry(&TicketServerData.SecretsKid, (void *) kid);
    if(entryPtr == NULL) return NULL;
    return DStringValue((DString *)GetHashValue(entryPtr));
}

```

```

/*
*-----
*
* GetKidByKeyID --
*
* Given an ascii KeyID return the binary Key ID.
* for untranslatable names, return -1.
*
* Results:
* "I've got a secret, now you do too"
*
* Side effects:
*
*
*-----
*/

```

```

int GetKidByKeyID(char *keyID)
{
    HashEntry *entryPtr;

    entryPtr = FindHashEntry(&TicketServerData.KeyID, (void *) keyID);
    if(entryPtr == NULL) return -1;
    return (int) GetHashValue(entryPtr);
}

```

-40-

```

/*
-----
*
* fieldParse --
*
* Given a string, a separator character, extracts a field up to the
* separator into the result string.
* Does substitution on '%XX' sequences, and returns the pointer to the
* character beyond last character in '*endptr'.
*
* Results:
* Returns a malloc'ed string (caller must free), or NULL if an
* error occurred during processing (such as an invalid '%' sequence).
*
* Side effects:
* None.
*
-----
*/
#define SIZE_INC 200
static char *fieldParse(char *str, char sep, char **endptr)
{
    char buf[3];
    char c;
    char *end, *data, *p;
    int maxlen, len;

    len = 0;
    maxlen = SIZE_INC;
    p = data = malloc(maxlen);

/*
* Loop through string, until end of string or sep character.
*/
while(*str && *str != sep) {

    if(*str == '%') {

        if(!isxdigit(str[1]) || !isxdigit(str[2])) {
            free(data);
            return NULL;
        }
        buf[0] = str [1];
        buf[1] = str [2];
        buf[2] = '\0';
        c = strtol(buf, &end, 16);
        str += 3;

```

-41-

```

    } else if(*str == '+') {
        c = ' ';
        str++;
    } else
        c = *str++;

    *p++ = c;
    len++;
    if(len >= maxlen) {
        maxlen += SIZE_INC;
        data = realloc(data, maxlen);
        p = data + len;
    }

    }
    *p++ = '\0';
    *endptr = str;
    return data;
}
/*
-----
*
* DomainNameCmd --
*
* A call to this routine, builds the ascii domain name
* to binary domain name mapping structure for a numeric domain.
* Syntax is Domain number name1 name2 name3 name...name_last
* At least one name is required. The number is decimal and
* can be any value except -1. -1 is reserved as a marker
* for untranslatable names.
*
* Results:
* None.
*
* Side effects:
* Commands are validate, and entries added to the map
*
-----
*/
static int DomainNameCmd(ClientData clientData, Tcl_Interp *interp,
                        int argc, char **argv)
{
    int new, i;
    HashEntry *entryPtr;
    int DomNumber;
    DString DomName;

```

-42-

```

if (argc <3)
{
    Tcl_AppendResult(interp, argv[0], " directive: wrong number of "
        "arguments, should be \"3\"",
        (char *) NULL);
    return TCL_ERROR;
}

DStringInit (&DomName);

if (((sscanf(argv[1], "%d", &DomNumber) != 1 || (DomNumber == -1)))
{
    Tcl_AppendResult(interp, argv[0], " directive: ",
        "Domain number must be an integer, and not equal to -1",
        ", value found was ", argv[1],
        (char *) NULL);
    return to TCL_ERROR;
}

for (i = 2; i < argc; i++)
{
    DStringFree (&DomName);
    DStringAppend(&DomName, argv[i], -1);
    strtolower(DString Value(&DomName));
    entryPtr = CreateHashEntry(&TicketServerData.Domains, DStringValue
        (&DomName)
    if (new == 0)
    {
        Tcl_AppendResult(interp, argv[0], " directive:

        "Duplicate domain name specified, '", argv[i], "'",
        (char *) NULL);
        return TCL_ERROR;
    }
    SetHashValue(entryPtr, DomNumber);
}

DStringFree (&DomName);
return TCL_OK;
}

/*
-----
*
*   SecretsCmd --
*
*   A call to this routine, builds kid to secrets table
*
*   Results:

```

-43-

```

* None.
*
* Side effects:
* Secrets are stored.
*
*-----
*/
static int SecretsCmd(ClientData clientData, Tcl_Interp *interp,
                    int argc, char **argv)
{
    int newKid, newKeyID;
    HashEntry *entryPtrKid = NULL, *entryPtrKeyID = NULL;
    int Kid;
    DString *dsptrKid;

    if (argc != 4)
    {
        Tcl_AppendResult(interp, argv[0], " directive: wrong number of "
            "arguments, should be \"4\" ",
            (char *) NULL);
        return TCL_ERROR;
    }

    if (sscanf(argv[2], "%d", &Kid) != 1)
    {
        Tcl_AppendResult(interp, argv[0],
            " directive: KeyID must be an integer",
            ", value found was '", argv[2], "'",
            (char *) NULL);
        return TCL_ERROR;
    }

    entryPtrKid = CreateHashEntry(&TicketServerData.SecretsKid, (void *) Kid, &n
    if (strlen(argv[1]))
        entryPtrKeyID = CreateHashEntry(&TicketServerData.KeyID, (void *) argv[1],
    if ((newKid == 0 || ((newKeyID == 0) && strlen(argv[1])))
    {
        Tcl_AppendResult(interp, argv[0],
            " directive: Duplicate Secret specified for KeyID '",
            argv[1],
            (char *) NULL);
        return TCL_ERROR;
    }
    if (strlen(argv[1]))
    {
        dsptrKid = (DString *) malloc(sizeof(DString));
        DStringInit(dsptrKid);

```

-44-

```

DStringAppend(dsptrKid, argv[3], -1);

SetHashValue(entryPtrKid, dsptrKid);
}
SetHashValue(entryPtrKeyID, Kid);
return TCL_OK;
}

/*
-----
*
* TICKET_Initialize --
*
* Calls all the necessary routines to initialize the ticket subsystem.
*
* Results:
*     None.
*
* Side effects:
*     Commands added to the region interpreter.
*     SID "/@" url catcher declared.
*
-----
*/
int TICKET_Initialize(HTTP_Server &serverPtr, Tcl_Interp *interp)
{
    TicketServerData.ticketExtensionId = HT_RegisterExtension(serverPtr,
    "ticket

    InitHashTable(&TicketServerData.SecretsKid, TCL_ONE_WORD_KEYS);
    InitHashTable(&TicketServerdata.KeyID,    TCL_STRING_KEYS);
    InitHashTable(&TicketServerData.Domains, TCL_STRING_KEYS);

    /* initialize Server ticket data */
    DStringInit(&TicketGlobalData(AuthServer));
    DStringInit(&TicketGlobalData(TicketExpHandler));
    DStringInit(&TicketGlobalData(TicketAdrHandler));
    TicketGlobalData(FreeArea)           = 0;
    TicketGlobalData(EnableLocalAuth)    = 0;
    TicketGlobalData(CurrentSecret)      = 0;
    TicketGlobalData(EnableSid)          = 0;
    TicketGlobalData(EnableTicket)       = 0;
    TicketGlobalData(EnableSidEater)     = 0;
    TicketGlobalData(LocalAuthExp)       = 60*30;

    /* ticket event counters */

```

-45-

```

TicketGlobalData (CountTotalUrl)           = 0;
TicketGlobalData (CountSidUrl)             = 0;
TicketGlobalData (CountValidSid)          = 0;
TicketGlobalData (CountExpSid)            = 0;
TicketGlobalData (CountInvalidSid)        = 0;
TicketGlobalData (CountCrossDomain)       = 0;
TicketGlobalData (CountLocalredirects)    = 0;
TicketGlobalData (CountRemoteRedirects)   = 0;
TicketGlobalData (CountNoRedirects)       = 0;
TicketGlobalData (CountDiscardedSidUrl)   = 0;

/* Ticket related Config commands */
Tcl_CreateCommand(interp, "Domain",
                  (ClientData) serverPtr, NULL);
                                                    DomainNameCmd,
Tcl_CreateCommand(interp, "Secrets",
                  (ClientData) serverPtr, NULL);
                                                    SecretsCmd,
Tcl_CreateCommand(interp, "AuthenticationServer", CmdStringValue,
                  (ClientData) &TicketGlobalData(AuthServer), NULL);
Tcl_CreateCommand(interp, "TicketExpirationHandler", CmdStringValue,
                  (ClientData) &TicketGlobalData(TicketExpHandler), NULL);
Tcl_CreateCommand(interp, "TicketAddressHandler", CmdStringValue,
                  (ClientData) &TicketGlobalData(TicketAdrHandler), NULL);
Tcl_CreateCommand(interp, "FreeDomain", CmdIntValue,
                  (ClientData) &TicketGlobalData(FreeArea), NULL);
Tcl_CreateCommand(interp, "EnableSidEater", CmdIntValue,
                  (ClientData) &TicketGlobalData(EnableSidEater), NULL);
Tcl_CreateCommand(interp, "EnableSid", CmdIntValue,
                  (ClientData) &TicketGlobalData(EnableSid), NULL);
Tcl_CreateCommand(interp, "EnableTicket", CmdIntValue,
                  (ClientData) &TicketGlobalData(EnableTicket), NULL);
Tcl_CreateCommand(interp, "EnableLocalAuth", CmdIntValue,
                  (ClientData) &TicketGlobalData(EnableLocalAuth), NULL);
Tcl_CreateCommand(interp, "CurrentSecret", CmdIntValue,
                  (ClientData) &TicketGlobalData(CurrentSecret), NULL);
Tcl_CreateCommand(interp, "LocalAuthExp", CmdIntValue,
                  (ClientData) &TicketGlobalData(LocalAuthExp), NULL);

HT_AddMounthandler(serverPtr, (ClientData) NULL, TICKET_DebugHooks,
                  "/omiserver", NULL);

return HT_OK;
}

```

/*

*

-46-

```

* TICKET_Shutdown --
*
* Calls all the necessary routines to shutdown the ticket subsystem.
*
* Results:
* None.
*
* Side effects:
* Memory freed
*
*-----
*/

void TICKET_Shutdown (HTTP_Server *serverPtr)
{
    HashEntry *entryPtr;
    HashSearch search;
    DString *dstring;

    DStringFree (&TicketGlobalData (AuthServer));
    DStringFree (&TicketGlobalData (TicketExpHandler));
    DStringFree (&TicketGlobalData (TicketAdrHandler));

    entryPtr = FirstHashEntry (&TicketServerData.SecretsKid, &search);
    while (entryPtr != NULL)
    {
        dstring = GetHashValue (entryPtr);
        DStringFree (dstring);
        free (dstring);
        entryPtr = NextHashEntry (&search);
    }
    DeleteHashTable (&TicketServerData.SecretsKid);
    DeleteHashTable (&TicketServerData.KeyID);
    DeleteHashTable (&TicketServerData.Domains);
}
/*
*
*-----
*
* TICKET_AddRegion Commands --
*
* Add TICKET region commands for authentication/authorization
decisions.
*
* Results:
    None.

```

-47-

```

*
* Side effects:
*       Commands added to the region interpreter.
*
*-----
*/

void TICKET_AddRegion Commands (HTTP_Request *reqPtr, Tcl_Interp *interp)
{
    Tcl_CreateCommand(interp, "RequireSID", TICKET_RequireSidCmd,
        (ClientData) reqPtr, NULL);
    Tcl_CreateCommand(interp, "RequireTicket", TICKET_RequireTicketCmd,
        (ClientData) reqPtr, NULL);
}

/*
*-----
*
* TICKET_GetCGIVariables --
*
*       Add TICKET CGI variables to the CGI variable table.
*
* Results:
*       None.
*
* Side effects:
*       Extends the CGI variable hash table.
*
*-----
*/

void TICKET_GetCGIVariables(HTTP_Request *req)
{
    TICKET_Request *ticketPtr = (TICKET_Request *)
HT_GetReqExtData(req.Tickets

    /*
    * If there's no extension data, then we're not doing a ticket. Just
return
    */

    if (ticketPtr == NULL)
        return);
}

```

-48-

```

    if (DStringLength(&ticketPtr->rawUrl) != 0)
        HT_AddCGIPParameter(req, "TICKET_URL", DStringValue(&ticketPtr-
>rawUrl), FA
    if (DStringLength (&ticketPtr->sid) != 0)
        HT_AddCGIPParameter(req, "TICKET_SID", DStringValue(&ticketPtr-
>sid), FALSE
    if (DStringLength(&ticketPtr->fields) != 0)
        HT_AddCGIPParameter(req, "TICKET_FIELDS", DStringValue(&ticketPtr-
>fields).
    if (DStringLength(&ticketPtr->signature) != 0)
        HT-AddCGIPParameter(req, "TICKET_SIGNATURE". DStringValue(&ticketPtr-
>signa
    }/*

```

```

*-----
*
*TICKET_GetUrl
*
*       Return the original url (with sid)
*
* Results:
*       The URL.
*
* Side effects:
*       None.
*
*-----
*/

```

```

char * TICKET_GetUrl(HTTP_Request *reqPtr)
{
    TICKET_Request *ticketPtr;

    ticketPtr = (TICKET_Request *)
        HT_GetReqExtData(reqPtr, TicketServerData.ticketExtensionId);
    if ((ticketPtr != NULL) &&
        (DStringLength(&ticketPtr->rawUrl) != 0))
        return DStringValue(&ticketPtr->rawUrl);
    else
        return DStringValue(&reqPtr->url);
}

```

```

/*
*-----
*
* TICKET_ConfigCheck
*
*       Perform late configuration checks

```

-49-

```

*
* Results:
*
*
* Side effects:
*     Possible message logged/printed, and program exit'd.
*
*-----
*/
void TICKET_ConfigCheck()
{
    HashEntry *entryPtr;
    int kid;

    if ((TicketGlobalData(EnableSid) & -0x1) != 0)
    {
        LogMessage(LOG_ERR, "EnableSid must be 0 or 1");
        exit (0);
    }
    if (!(TicketGlobalData(EnableSid))) return;

    kid = TicketGlobalData(CurrentSecret);
    if (kid && kid_mask) != kid)
    {
        LogMessage(LOG_ERR, "CurrentSecret %d is invalid", kid);
        exit(0);
    }

    entryPtr = FindHashEntry(&TicketServerData.SecretsKid, (void *) kid);

    if(entryPtr == NULL)
    {
        LogMessage(LOG_ERR), "No secret defined for CurrentSecret %d", kid;
        exit(0);
    }

    if ((TicketGlobalData(FreeArea) & ~0x255) != 0)
    {
        LogMessage(LOG_ERR, "FreeArea must be between 0 and 255");
        exit(0);
    }

    if ((TicketGlobalData(EnableSidTicket) & -0x1) != 0)
    {
        LogMessage(LOG_ERR, "EnableSidTicket must be 0 or 1");
        exit (0);
    }
}

```

-50-

```

    if ((TicketGlobalData(EnableTicket) & -0x1) != 0);
    {
        LogMessage(LOG_ERR, "EnableTicket must be 0 or 1");
        exit(0);
    }

    if ((TicketGlobalData(EnableLocalAuth) & -0x1) != 0)
    {
        LogMessage(LOG_ERR, "EnablLocalAuth must be 0 or 1");
        exit (0);
    }
}

/*
-----
*
*
* TICKET_DebugHooks
*
*   Check for debug hooks and execute if found.
*
* Results:
*   None.
*
* Side Effects:
*   None.
*
-----
*/
static void TICKET_DebugHooks(ClientData clientData, char *suffix,
                             HTTP_Request *reqPtr)
{
    if(strcmp(suffix, "/ticketstatus") == 0)
    {
        DumpStatus(reqPtr);
        HT_FinishRequest(reqPtr);
        return;
    }
    HTTP_Error(reqPtr, NOT_FOUND, "access denied due to poorly formed url");
    HT_FinishRequest(reqPtr);
    return;
}

/*
-----
*
*
* DumpStatus --
*
*   Dump the server's ticket stat's
*

```

-51-

```

* Results:
*   None.
*
* Side effects:
*   None.
*
*-----
*/
#define BUFSIZE 1024
static void DumpStatus(HTTP_Request *reqPtr)
{
    HTTP_Server *serverPtr = reqPtr->serverPtr;
    char tmp[BUFSIZE], timeStr[BUFSIZE];
    struct utsname sysinfo;
    time_t uptime;
    int hours;

    HTTP_BeginHeader(reqPtr, "200 OK");
    HTTP_SendHeader(reqPtr, "Content-type: text/html", NULL);
    HTTP_EndHeader(reqPtr);
    HTTP_Send(reqPtr, "<title>WebServer Ticket Status</title>",
              "<h1>WebServer Ticket Status</h1>:", NULL);

    HTTP_Send(reqPtr, "<p><hr><p><h2>Ticket Log</h2>", "<p><pre>\n", NULL);

    sprintf(tmp, "   <b>%s: </b> %d\n", "Number of access          ", Ticket
    HTTP_Send(reqPtr, tmp, NULL);
    sprintf(tmp, "   <b>%s: </b> %d\n", "Number of SID URL's          ", Ticket
    HTTP_Send(reqPtr, tmp, NULL);
    sprintf (tmp, "   <b>%s: </b> %d\n:", "Number of Valid SID's          ", Ticket
    HTTP)Send(reqPtr, tmp, NULL);
    sprintf (tmp, "   <b>%s: </b> %d\n:", "Number of Expired SID's   ", Ticket
    HTTP)Send(reqPtr, tmp, NULL);
    sprintf (tmp, "   <b>%s: </b> %d\n:", "Number of Invalid SID's  ", Ticket
    HTTP)Send(reqPtr, tmp, NULL);
    sprintf (tmp, "   <b>%s: </b> %d\n:", "Number of XDomain accesses ", Ticket
    HTTP)Send(reqPtr, tmp, NULL);
    sprintf (tmp, "   <b>%s: </b> %d\n:", "Number of Local Redirects ", Ticket
    HTTP)Send(reqPtr, tmp, NULL);
    sprintf (tmp, "   <b>%s: </b> %d\n:", "Number of Remote Redirects ", Ticket
    HTTP)Send(reqPtr, tmp, NULL);
    sprintf (tmp, "   <b>%s: </b> %d\n:", "Number of No Auth servers ", Ticket

    HTTP_Send(reqPtr, tmp, "</pre>", NULL);

    uptime = time (NULL) - serverPtr->started;
    uname(&sysinfo);

```

-52-

```

striftime(timeStr, BUFSIZE, "%A, %d-%b-%y %T",
    localtime(serverPtr->started));

sprintf(tmp, "Server runing on <d>%s</b> (%s %s) port %d, has been up \
    since %s.<p>", sysinfo.nodename, sysinfo.sysname,
    sysinfo.release, serverPtr->server_port, timeStr);
HTTP_Send(reqPtr, tmp, NULL);

sprintf(tmp, "    <b>Number of connections:           </b> %d\n",
    serverPtr->numConnects);
HTTP_Send(reqPtr, tmp, "<p><pre>\n", tmp, NULL);
sprintf(tmp, "    <b>Number of HTTP requests:         </b> %d\n",
    serverPtr->numRequests);
HTTP_Send(reqPtr, tmp, "</pre><p>", NULL);

hours = max(uptime / 3600, 1);
sprintf(tmp, "This server is averaging <b>%d</b> requests per hour.<p>",
    serverPtr->numRequests/hours);
HTTP_Send(reqPtr, tmp, NULL);

DumpRusage(reqPtr);
/*    DumpConnections(reqPtr); */

DNS_DumpStats(reqPtr);

HTTP_Send(reqPtr, "<p><hr><address>", DStringValue(&ht_serverSoftware),
    "</address>\n", NULL);

reqPtr->done = TRUE;

}
#endif BUFSIZE

```

CLAIMS

What is claimed is:

1. A method of processing service requests from a client to a server system through a network comprising:
5 forwarding a service request from the client to the server system;
returning a session identifier from the server system to the client; and
10 appending the session identifier to the request and subsequent service requests from the client to the server system within a session of requests.
2. A method as claimed in Claim 1 wherein the server system tracks an access history of sequences of service requests within the session of requests.
- 15 3. A method as claimed in Claim 2 wherein the server system tracks the access history to determine service requests leading to a purchase made within the session of requests.
4. A method as claimed in Claim 1 wherein the server
20 system counts requests to particular services exclusive of repeated requests from a common client.
5. A method as claimed in Claim 1 wherein the server
25 system maintains a database relating customer information to access patterns, the information including customer demographics.

6. A method as claimed in Claim 1 wherein the server system subjects the client to an authorization routine prior to issuing the session identifier and the session identifier is protected from forgery.
- 5 7. A method as claimed in Claim 6 wherein the server system comprises plural servers including an authentication server which provides session identifiers for service requests to multiple servers.
8. A method as claimed in Claim 7 wherein:
- 10 a client directs a service request to a first server which is to provide the requested service;
the first server checks the service request for a session identifier and only services a service request having a valid session identifier, and where the
- 15 service request has no valid identifier:
the first server redirects the service request from the client to the authorization server;
the authorization server subjects the client to the authorization routine and issues the session
- 20 identifier to be appended to the service request to the first server;
the client forwards the service request appended with the session identifier to the first server; and
- 25 the first server recognizes the session identifier and services the service request to the client; and
the client appends the session identifier to subsequent service requests to the server system and
- 30 is serviced without further authorization.
9. A method as claimed in Claims 1 or 7 wherein the session identifier includes a user identifier.

10. A method as claimed in Claims 1 or 7 wherein the session identifier includes an expiration time for the session.
- 5 11. A method as claimed in Claim 7 wherein the session identifier provides access to a protected domain to which the session has access authorization.
12. A method as claimed in Claim 11 wherein the session identifier is modified for access to a different protected domain.
- 10 13. A method as claimed in Claim 7 wherein the session identifier provides a key identifier for key management.
14. A method as claimed in Claims 1 or 7 wherein the server system records information from the session identifier in a transaction log in the server system.
- 15 15. A method as claimed in Claims 1 or 7 wherein communications between the client and server system are according to hypertext transfer protocol and the session identifier is appended as part of a path name in a uniform resource locator.
- 20 16. A method as claimed in Claim 15 wherein the client modifies the path name of a current uniform resource locator using relative addressing and retains the session identifier portion of the path name unmodified for successive requests in the session.
- 25

17. A method as claimed in Claim 1 or 7 further comprising excluding requests made to information from the client within a defined period of time.
- 5 18. A method of processing service requests from a client to a server system through a network comprising:
 responding to a request for a document received from the client through the network;
 appending a session identifier, which includes a user identification, to the request; and
10 returning the requested document wherein the document is customized for a particular user based on the user identification of the session identifier.
19. A method of processing service request for a document received from a client through network in which the
15 document has been purchased by a user comprising:
 responding to a request for a document received from a client through the network in which the document has been purchased by the user;
 appending an authorization identifier to the
20 request; and
 returning the requested document if the authorization identifier indicates that the user is authorized to access the document.
20. A method as claimed in Claim 19, wherein the
25 authorization identifier is encoded within a session identifier which is appended to the request.
21. A method of processing service requests from a client to a server system through a network comprising:
 responding to a request for a document received
30 from a client through the network;
 appending a user identifier to the request;

returning the requested document to the client,
and;
charging the user identified in the identifier
for access to the document.

- 5 22. A method as claimed in Claim 21, wherein a user
identifier is encoded within a session identifier
which is appended to the request.
23. A method of processing service requests from a client
to a server system through a network comprising:
10 forwarding a service request from the client to
the server system; and
appending a session identifier to the request and
subsequent service requests from the client to the
server system within a session of requests.
- 15 24. An information system on a network comprising:
means for receiving service requests from clients
and for determining whether a service request includes
a session identifier;
means for providing the session identifier in
20 response to an initial service request in a session of
requests; and
means for servicing service requests from a
client which include the session identifier, the
subsequent service request being processed in the
25 session.
25. An information system as claimed in Claim 24 wherein
the means for providing the session identifier is in a
server system which services the requests.
- 30 26. An information system as claimed in Claim 23 further
comprising an authorization routine for authorizing

the client prior to issuing the session identifier and means for protecting the session identifier from forgery.

- 5 27. An information system as claimed in Claim 24 further comprising a transaction log for recording information from the session identifier.
28. An information system as claimed in Claim 24 further comprising means for tracking access history of sequences of service requests within the session.
- 10 29. An information system as claimed in Claim 24 further comprising means for counting requests to particular services exclusive of repeated requests from a common client.
- 15 30. An information system as claimed in Claim 24 further comprising a database relating customer information to access patterns, the information including customer demographics.
- 20 31. An information system as claimed in Claim 25 wherein communications between the client and server system are according to hypertext transfer protocol and the session identifier is appended as part of a path name in a uniform resource locator.
- 25 32. An information server on a network comprising:
means for responding to requests for hypertext pages received from a client through the network by returning the requested hypertext pages to the client;
means for responding to further requests derived from links in the hypertext pages; and

means for tracking the further requests derived from a particular hypertext page.

33. An information server as claimed in Claim 32 wherein the requests include a common session identifier and the server tracks requests within a session of requests.
34. An information server as claimed in Claim 32 further comprising a data base relating customer demographics to access patterns.
35. A method of providing access to information pages from a client to a server system through a network comprising:
- providing a telephone number at the client;
 - mapping the telephone number to a target page identifier using a translation database;
 - requesting information described by the page identifier from the server system; and
 - displaying a page identified by the page identifier at the client.
36. A method of providing access to information pages from a client to a server system through a network comprising:
- providing a descriptor at the client;
 - mapping the descriptor to a target page identifier using a translation database;
 - requesting at the client information described by the page identifier from the server system without further user action; and
 - displaying a page identified by the page identifier at the client.

- 5 37. A method as claimed in Claims 35 or 36 wherein the translation database resides in the server system which returns a uniform resource loctor in a REDIRECT command to the client to cause the client to request the information using the uniform resource locator.
38. A method as claimed in Claim 36 wherein the descriptor comprises a telephone number.
39. A method as claimed in Claim 36 wherein the descriptor comprises a descriptive term.
- 10 40. A method as claimed in Claim 39 wherein the term includes a company name.
41. A method as claimed in Claim 39 wherein the term includes a product name.
- 15 42. A method as claimed in Claim 39 wherein the term is identified by phonetic mapping.
43. A method as claimed in Claims 35 or 38 wherein the target page identifier describes a controlled page.
44. A method as claimed in Claims 35 or 36 wherein the target page identifier is a uniform resource locator.

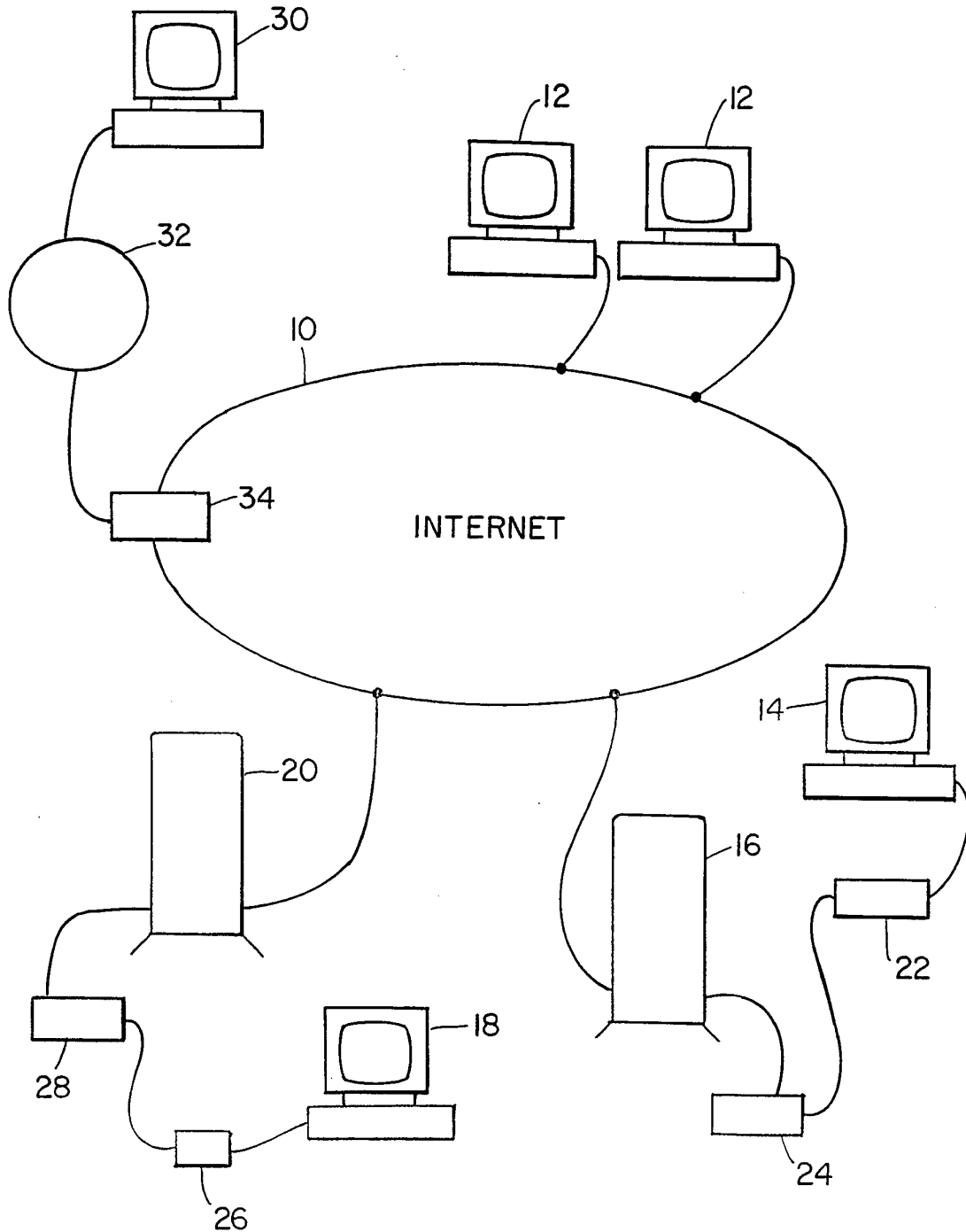

FIG. 1

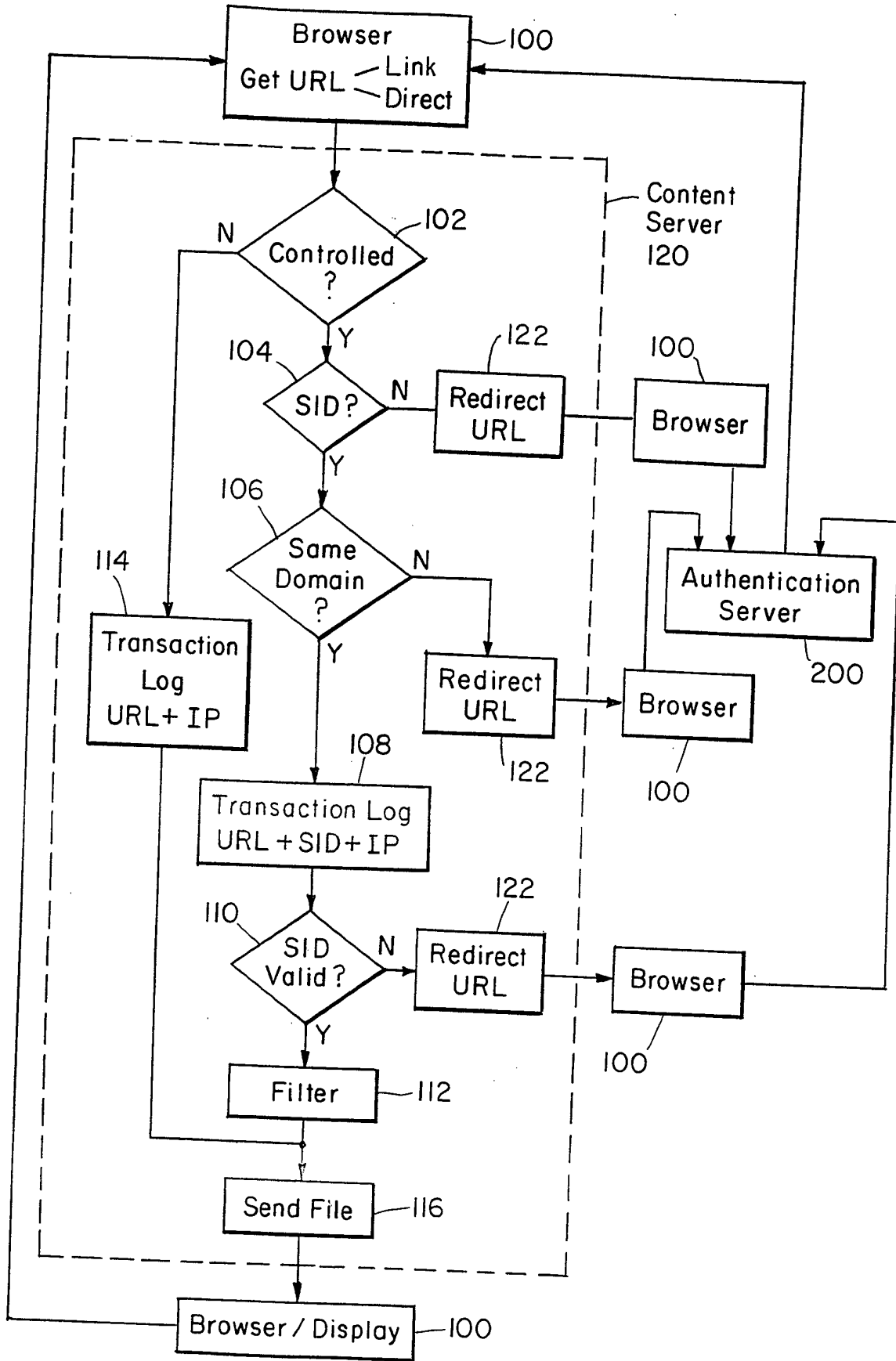

FIG. 2A

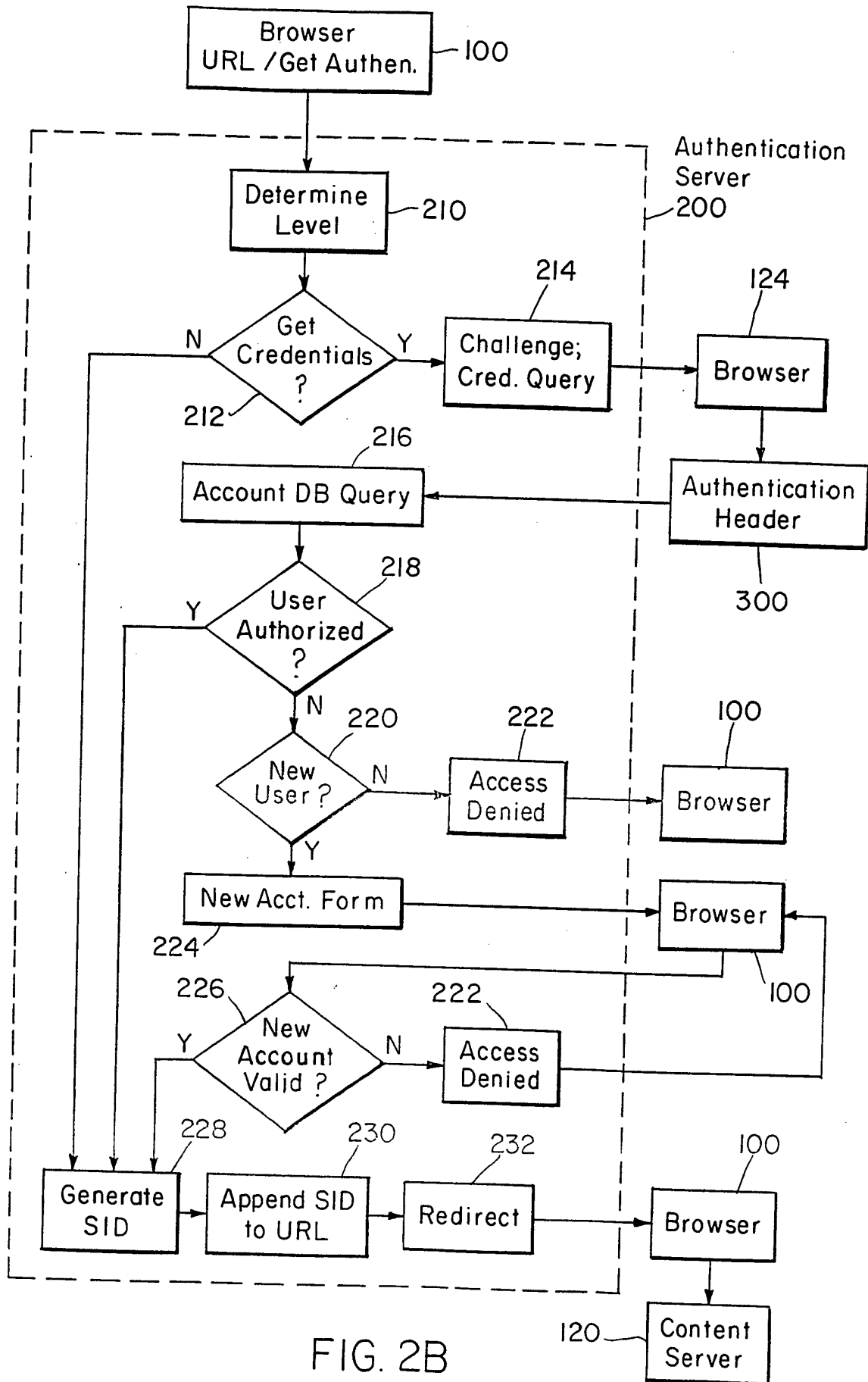

FIG. 2B

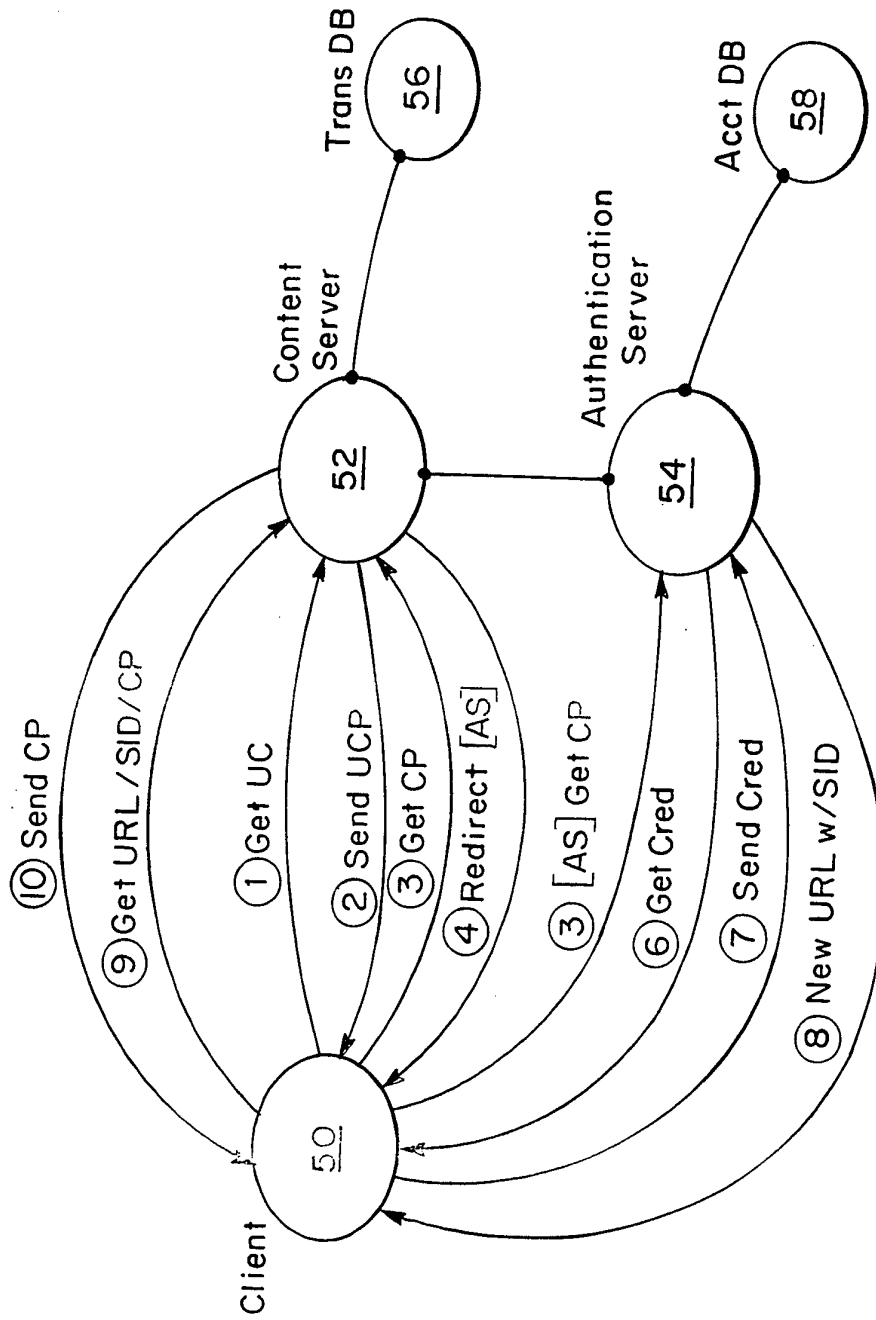

FIG. 3

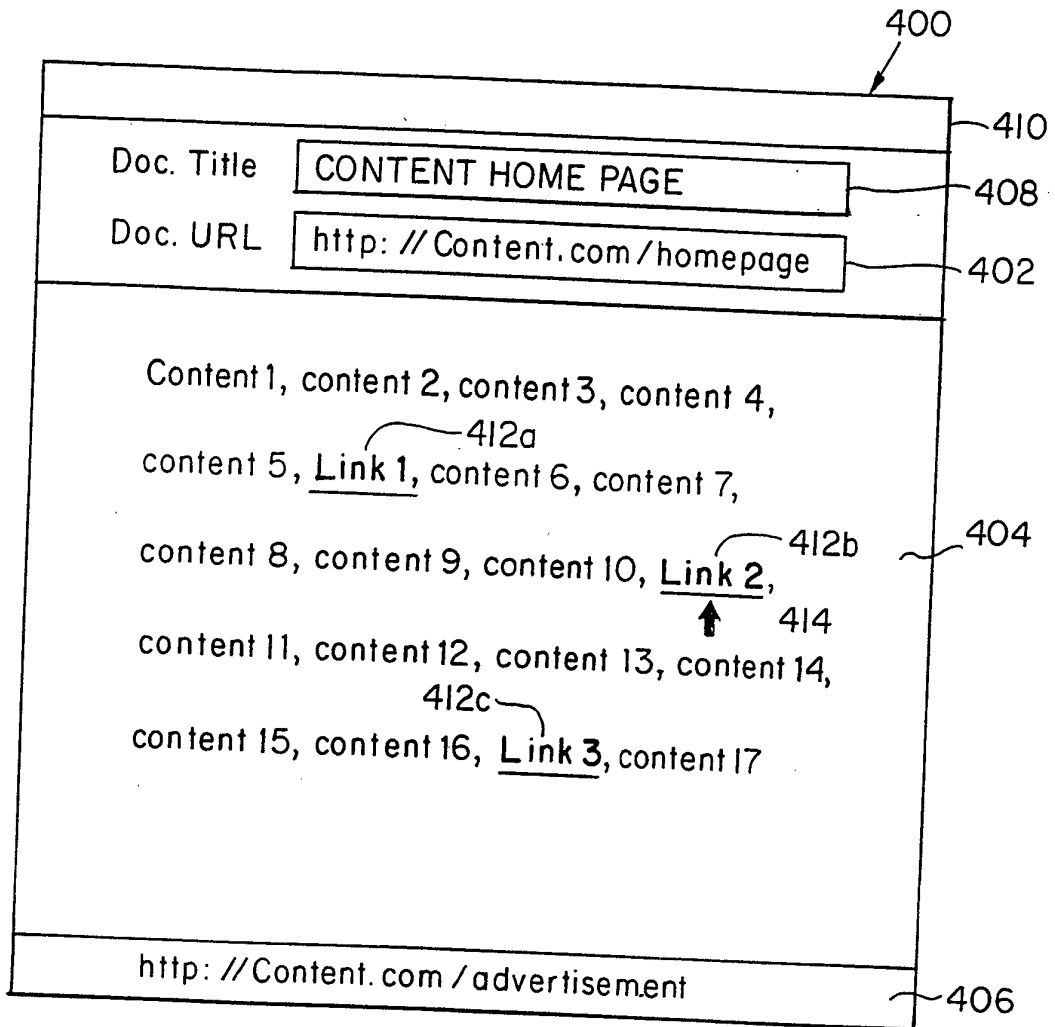

FIG. 4

Document View	
<u>F</u> ile	<u>O</u> ptions
<u>N</u> avigate	<u>A</u> nnotate
<u>D</u> ocuments	<u>H</u> elp
Title:	<input type="text" value="How to join"/>
URL:	<input type="text" value="http: //auth. com/ service/ nph- createacct. cgi"/>
1. First name	<input type="text"/>
2. Last name	<input type="text"/>
3. Choose a screen name (no more than 15 characters)	<input type="text"/>
4. Choose a password (no more than 15 characters)	
Password:	<input type="text"/>
Re-enter password:	<input type="text"/>
5. E-mail address	<input type="text"/>
6. Your birthdate (MM/DD/YY)	<input type="text"/>
7. U. S. zip code, or country code	
Zip/postal code:	<input type="text"/>
ISO country code	<input type="text" value="US"/>

FIG. 5

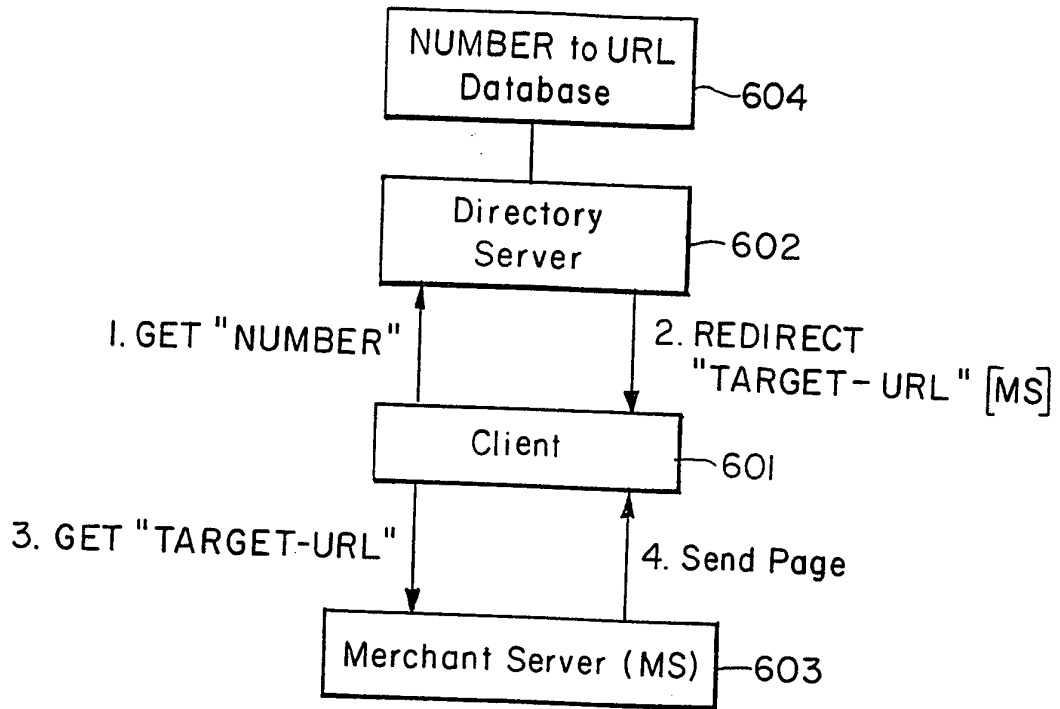

FIG. 6