

(19)



Europäisches Patentamt
European Patent Office
Office européen des brevets



(11)

EP 1 445 491 A1

(12)

EUROPEAN PATENT APPLICATION

(43) Date of publication:
11.08.2004 Bulletin 2004/33

(51) Int Cl.7: F04C 29/00, F04C 29/04

(21) Application number: 04002443.2

(22) Date of filing: 04.02.2004

(84) Designated Contracting States:
AT BE BG CH CY CZ DE DK EE ES FI FR GB GR
HU IE IT LI LU MC NL PT RO SE SI SK TR
Designated Extension States:
AL LT LV MK

- Fujii, Toshiro
Kariya-shi, Aichi-ken (JP)
- Hoshino, Tatsuyuki
Kariya-shi, Aichi-ken (JP)
- Okada, Masahiko
Kariya-shi, Aichi-ken (JP)

(30) Priority: 05.02.2003 JP 2003028401
10.03.2003 JP 2003063608

(74) Representative:
Leson, Thomas Johannes Alois, Dipl.-Ing.
Patentanwälte
Tiedtke-Bühling-Kinne & Partner,
Bavariaring 4
80336 München (DE)

(71) Applicant: Kabushiki Kaisha Toyota Jidoshokki
Kariya-shi, Aichi-ken (JP)

(72) Inventors:
• Nakane, Yoshiyuki
Kariya-shi, Aichi-ken (JP)

(54) Compressor for and method of simultaneously cooling and filtering the gas

(57) A scroll type compressor includes a fixed scroll member (20) and a movable scroll member (24) to define compression chambers. The movable scroll member orbits relative to the fixed scroll member to compress gas in the compression chambers. The compressed gas is discharged to a discharge port (20d). The compressor

also includes a filter chamber (44) and a cooling chamber (32). The filter chamber communicates with the discharge port for accommodating a first filter (55) to at least partially filter the compressed gas. The cooling chamber is located adjacent to the filter chamber for containing coolant fluid that cools the compressed gas in the filter chamber.

FIG. 1

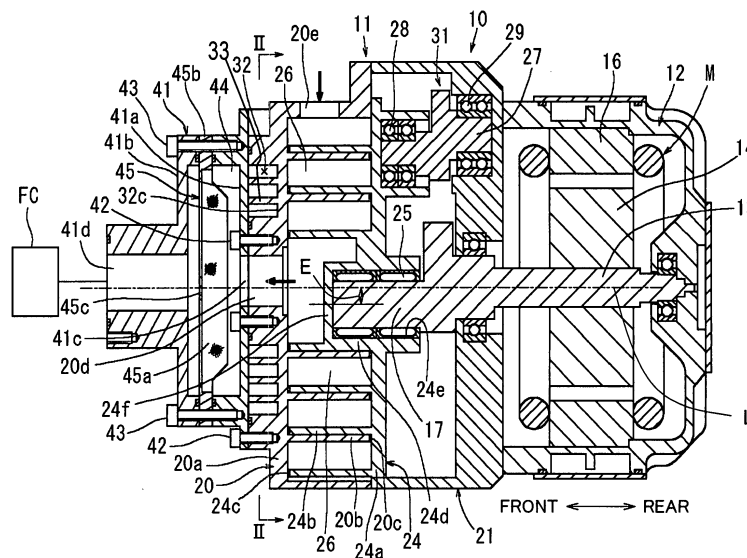

EP 1 445 491 A1

Description

BACKGROUND OF THE INVENTION

[0001] The present invention relates to a compressor that compresses gas to be supplied preferably to a fuel cell, and more particularly to a technique for cooling the gas and removing foreign substances in the gas, such as abrasion powder, from the gas.

[0002] In a scroll type compressor, as gas is compressed, the temperature of the gas rises. Then, the compressed gas is discharged from a compression chamber. When the discharged gas at a high temperature flows out from the compressor to an external circuit, it is possible for the high temperature gas to give a thermally adverse effect to a device on a downstream side in the external circuit. As disclosed in Japanese Unexamined Patent Publication No. 2002-295386, a technique is known to avoid such thermally adverse effect on the downstream device, and the gas is cooled to a temperature that gives no thermally adverse effect to the downstream device before the gas flows out of a compressor. In the above cooling technique, a cooling chamber is disposed adjacent to a compression chamber, and a gas cooler that has a gas passage leading to a discharge port is arranged adjacent to the cooling chamber. Therefore, heat is exchanged between coolant fluid in the cooling chamber and the discharged gas in the gas passage so that the discharged gas is cooled while the discharged gas passes through the gas passage.

[0003] Meanwhile, when the scroll type compressor is operated, spiral walls of movable and fixed scroll members slide relative to each other, and tip seals at the axially distal ends of the spiral walls slide relative to base plates of the scroll members. Sliding surfaces abrade due to these sliding actions, and the abrasion produces abrasion powder. The abrasion powder is mixed in the gas and flows out to the external circuit. Although it adversely affects the downstream device, preventive measures against such abrasion powder have not been taken in the scroll type compressor in prior art.

[0004] Incidentally, Japanese unexamined Patent Publication No. 2000-213831 discloses a technique in which a filter is provided in a conduit for collecting the abrasion powder in the gas that flows in the conduit. The above filter collects abrasion powder that is produced in the compressor and that is discharged to the outside of the compressor with the gas so as to prevent the abrasion powder from flowing into the downstream device. However, in the above structure, there is a limit to enlarge a cross section of a filter passage. Because of the small cross-sectional area, the filter is easily clogged, and the compression pressure is reduced.

SUMMARY OF THE INVENTION

[0005] The present invention provides a technique to

effectively cool gas and to simultaneously remove foreign substances from the gas in a compressor before the discharged gas from a discharge port flows out to an external circuit.

[0006] According to the present invention, a scroll type compressor includes a fixed scroll member and a movable scroll member to define compression chambers. The movable scroll member orbits relative to the fixed scroll member to compress gas in the compression chambers. The compressed gas is discharged to a discharge port. The compressor also includes a filter chamber and a cooling chamber. The filter chamber communicates with the discharge port for accommodating a first filter to at least partially filter the compressed gas. The cooling chamber is located adjacent to the filter chamber for containing coolant fluid that cools the compressed gas in the filter chamber.

[0007] The present invention also provides a method of processing compressed gas in a compressor. The compressor forms a compression chambers for compressing the gas, a filter chamber having a filter and a cooling chamber that is located adjacent to the filter chamber for containing coolant fluid. The method includes the steps of transmitting cooling temperature of the coolant fluid to the filter chamber, cooling the compressed gas in the filter chamber and removing foreign substances in the compressed gas through the filter in the filter chamber simultaneously with the above cooling step.

[0008] The present invention also provides a compressor for compressing gas. The compressor includes a filter chamber and a cooling chamber. The filter chamber accommodates a filter so as to at least partially filter the compressed gas. The cooling chamber is located adjacent to the filter chamber for containing coolant fluid so that cooling temperature of the coolant fluid is transmitted to the filter chamber.

[0009] The present invention also provides a cooling circuit for cooling gas in a compressor that compresses the gas. The cooling circuit includes a filter chamber, a cooling chamber, a heat exchanger and a pump. The filter chamber is located in the compressor and accommodates a filter to filter at least partially the compressed gas. The cooling chamber is located in the compressor adjacent to the filter chamber for passing coolant fluid. The heat exchanger is connected to the cooling chamber for cooling the coolant fluid from the cooling chamber. The pump connected to the heat exchanger for supplying the coolant fluid to the cooling chamber.

BRIEF DESCRIPTION OF THE DRAWINGS

[0010] The features of the present invention that are believed to be novel are set forth with particularity in the appended claims. The invention together with objects and advantages thereof, may best be understood by reference to the following description of the presently preferred embodiments together with the accompanying

drawings in which:

FIG. 1 is a longitudinal cross-sectional view of a scroll type compressor according to a first preferred embodiment of the present invention;

FIG. 2 is a cross-sectional view of the scroll type compressor taken along the line II-II in FIG. 1;

FIG. 3 is a perspective view of a filter according to the first preferred embodiment of the present invention;

FIG. 4 is a partially enlarged cross-sectional view of a scroll type compressor according to a second preferred embodiment of the present invention;

FIG. 5 is a perspective view of a filter on an upstream side according to the second preferred embodiment of the present invention;

FIG. 6 is a perspective view of a filter according to a first alternative embodiment of the present invention;

FIG. 7 is a perspective view of a filter according to a second alternative embodiment of the present invention;

FIG. 8 is a perspective view of a filter according to a third alternative embodiment of the present invention;

FIG. 9 is a cross-sectional view showing a filter according to a fourth alternative embodiment of the present invention;

FIG. 10 is a cross-sectional view showing a support structure for a filter on an upstream side according to a fifth alternative embodiment;

FIG. 11 is a cross-sectional view showing a support structure for a filter on an upstream side according to a sixth alternative embodiment; and

FIG. 12 is a cross-sectional view showing an open-close structure of an escape passage for a filter on an upstream side according to a seventh alternative embodiment.

DETAILED DESCRIPTION OF THE PREFERRED EMBODIMENTS

[0011] A first preferred embodiment will be now described in reference to FIGS. 1 through 3. FIG. 1 is a longitudinal cross-sectional view of a scroll type electric compressor 10 according to the first preferred embodiment of the present invention. FIG. 2 is a cross-sectional

view of the compressor 10 taken along the line II-II in FIG. 1. FIG. 3 is a perspective view of a filter. The left and right sides of FIG. 1 respectively correspond to the front and rear sides of the compressor 10.

[0012] The present preferred embodiment is applied for compressing gas, and it is more particularly applied for compressing air which is supplied to a fuel cell in an electric vehicle. An outer hull of the compressor 10 includes a front housing 11 and a rear housing 12 both of which are made of aluminum or aluminum alloy. A rotary shaft 13 is rotatably supported in the front and rear housings 11 and 12. A rotor 14 constituting an electric motor M is rotatably mounted on the rotary shaft 13 in the rear housing 12. A stator 16 constituting the electric motor M is fixedly arranged on the inner circumferential surface of the rear housing 12 so as to surround the rotor 14.

[0013] The front housing 11 includes a fixed scroll member 20, a filter casing 41 and a support housing 21. The filter casing 41 is fixedly joined to the front end of the fixed scroll member 20. The support housing 21 is fixedly joined to the rear end of the fixed scroll member 20 and to the front end of the rear housing 12. The fixed scroll member 20 includes a fixed base plate 20a that has a substantially disc-shaped configuration and a fixed spiral wall 20b that extends from the rear surface of the fixed base plate 20a.

[0014] A crankshaft 17 is provided at the front end of the rotary shaft 13 and is offset from an axis L of the rotary shaft 13 by a predetermined length E of eccentricity. A movable scroll member 24 is rotatably supported by the crankshaft 17 through a pair of bearings 25 so as to face the fixed scroll member 20. The movable scroll member 24 includes a movable base plate 24a that is substantially disc-shaped and a movable spiral wall 24b that extends from the front surface of the movable base plate 24b.

[0015] The fixed and movable scroll members 20 and 24 are arranged so as to engage with each other. The distal end surfaces of the fixed and movable spiral walls 20b and 24b respectively contact the movable and fixed base plates 24a and 20a at tip seals 20c and 24c. The fixed spiral wall 20b overlaps the movable spiral wall 24b to contact each other at a plurality of points. Therefore, the fixed base plate 20a and the fixed spiral wall 20b of the fixed scroll member 20 as well as the movable base plate 24a and the movable spiral wall 24b of the movable scroll member 24 define a plurality of falcate compression chambers 26.

[0016] A boss 24d is formed at the intermediate portion of the movable base plate 24a of the movable scroll member 24. The boss 24d axially protrudes toward the front side of the compressor 10. An inserting recess 24e is formed in the boss 24d for accepting the crankshaft 17 thereinto. In the inserting recess 24e, a bottom wall 24f of the boss 24d is formed at the front side opposite to an opening and rear side where the crankshaft 17 is inserted. Thus, the crankshaft 17 protrudes from the movable base plate 24a toward the fixed base plate 20a.

Consequently, the compressor 10 is shortened along the axis L of the rotary shaft 13 by a partial length of the crankshaft 17 that protrudes from the movable base plate 24a toward the fixed base plate 20a.

[0017] A discharge port 20d is formed in the center of the fixed base plate 20a of the fixed scroll member 20. A suction port 20e is formed in the outer circumferential wall of the fixed scroll member 20. A self-rotation preventing mechanism 31 includes a crankshaft 27 and bearings 28 and 29. The self-rotation preventing mechanism 31 is located between the movable base plate 24a of the movable scroll member 24 and the inner wall surface of the support housing 21 that faces the movable base plate 24a of the movable scroll member 24.

[0018] As the rotary shaft 13 is rotated by the electric motor M, the movable scroll member 24 orbits around the axis of the fixed scroll member 20 by the crankshaft 17. At the same time, the self-rotation preventing mechanism 31 prevents the movable scroll member 24 from self-rotating while it allows the movable scroll member 24 to orbit around the axis of the fixed scroll member 20. As the compression chambers 26 move inwardly from an outer circumferential side of the fixed and movable spiral walls 20b and 24b by the orbital movement, the compression chambers 26 reduce in volume. Thereby, the air introduced from the suction port 20e into the compression chambers 26 is compressed. The compressed air is discharged from the compression chambers 26 to a filter chamber 44 through the discharge port 20d when the compression chambers 26 have approached the center of the fixed base plate 20a.

[0019] A cooling chamber 32 is defined between the front surface of the fixed scroll member 20 and the filter casing 41, the filter casing 41 is fixed to the fixed scroll member 20. Specifically, a recess 32c is formed at the front side of the fixed base plate 20a of the fixed scroll member 20, and the filter casing 41 is fixed to the front surface of the fixed base plate 20a so as to cover the recess 32c. Accordingly, the cooling chamber 32 is adjacent to the compression chambers 26 across the fixed base plate 20a.

[0020] As shown in FIG. 2, the cooling chamber 32 is formed in a substantially U-shaped manner so as to surround the discharge port 20d. The cooling chamber 32 has a coolant inlet 32a for flowing cooling water as coolant fluid into the cooling chamber 32 and a coolant outlet 32b for removing the cooling water. A plurality of flow-dividing fins 33 is provided in the cooling chamber 32. The flow-dividing fins 33 divide the flow of the cooling water flowing in from the coolant inlet 32a, and the cooling water flows toward the coolant outlet 32b. In the present preferred embodiment, the flow-dividing fins 33 extend from the front surface of the fixed base plate 20a of the fixed scroll member 20. The cooling chamber 32 partially constitutes a cooling circuit. As shown in FIG. 2, a heat exchanger and a pump are provided in the cooling circuit. The heat exchanger cools the high-temperature cooling water that flows out from the coolant

outlet 32b. The pump supplies the cooling water that has been cooled into the cooling chamber 32 through the coolant inlet 32a. Pure water generated by cell reaction at a fuel cell FC as shown in FIG. 1 is utilized as the cooling water that circulates in the cooling circuit.

[0021] Referring back to FIG. 1, the filter casing 41 has a two-part structure including an inner casing 41a at the rear side and an outer casing 41b at the front side. The inner casing 41a is fixed to the front surface of the fixed scroll member 20 by a predetermined number of bolts 42 while the outer casing 41b is fixed to the inner casing 41a by a predetermined number of bolts 43. Namely, the outer casing 41b is detachable from the inner casing 41a. As necessary, the outer casing 41b is detached from the inner casing 41a. The inner and outer casings 41a and 41b define the filter chamber 44. The filter chamber 44 is adjacent to the cooling chamber 32 across the inner casing 41a. Namely, the cooling chamber 32 is located between the compression chambers 26 and the filter chamber 44. Also, the inner casing 41a contacts the flow-dividing fins 33.

[0022] Still referring to FIGS. 1 and 2, the filter chamber 44 accommodates a filter 45 for removing foreign substances when the compressed air is introduced from the discharge port 20d into the filter chamber 44. The filter 45 includes a filter portion 45a for removing the foreign substances and a frame 45b arranged around the edges of the filter portion 45a for supporting the filter portion 45a.

[0023] The filter 45 is schematically illustrated in FIG. 3. In the filter 45, the frame 45b preferably includes a rib 45c for reinforcing. In order to enhance capacity for collecting the foreign substances and cooling effect, the filter portion 45a is preferably a pleated type filter element that has been formed by bending a flat stainless screen in zigzags. The filter 45 is supported in such a manner that the filter 45 is sandwiched by the inner and outer casings 41a and 41b. As shown in FIG. 1, the filter portion 45a is suspended in the filter chamber 44.

[0024] Referring to FIG. 1, a communication hole 41c is formed as an inlet in the center of the inner casing 41a. The filter chamber 44 communicates with the discharge port 20d of the compression chamber 26 through the communication hole 41c. An outlet 41d is formed in the center of the outer casing 41b. That is, the compressed air discharged from the discharge port 20d of the compression chamber 26 is inputted to the filter chamber 44 through the communication hole 41c. After passing through the filter 45, the compressed air is outputted through the outlet 41d to the fuel cell FC, which is located outside of the compressor 10. The compressed air flows in the filter chamber 44 substantially in the same direction as the compressed air flows in the discharge port 20d as shown by an arrow in FIG. 1. Also, the filter 45 is located so as to be perpendicular to the above flow direction.

[0025] Referring to FIGS. 1 and 2, as the compressor 10 is operated, the cooling water flows into the cooling

chamber 32 from the coolant inlet 32a. The cooling water flowing into the cooling chamber 32 cools the air that is being compressed in the compression chambers 26 and the discharged air in the filter chamber 44. Namely, heat is exchanged between the cooling water in the cooling chamber 32 and the compressed air in the compression chambers 26 through the fixed base plate 20a as well as between the cooling water and the compressed gas in the filter chamber 44 through the inner casing 41a. More specifically, cooling temperature of the cooling water is transmitted to the compressed air in the compression chambers 26 through the fixed base plate 20a as well as the compressed gas in the filter chamber 44 through the inner casing 41a. The cooling water that has been used for cooling flows out from the coolant outlet 32b and is substantially cooled by the heat exchanger to circulate back into the cooling chamber 32 by the pump. Namely, as the cooling water circulates in the cooling circuit, the temperature of the cooling water repeatedly rises and lowers. A part of the cooling water that flows out from the coolant outlet 32b is discarded, and the same amount of the pure water generated at the fuel cell FC is added into the cooling circuit for the discarded part.

[0026] In accordance with the operation of the compressor 10, the movable spiral wall 24b rotates relative to the fixed spiral wall 20b while the movable spiral wall 24b contacts the fixed spiral wall 20b. That is, the movable spiral wall 24b slides over the fixed spiral wall 20b. Also, the tip seals 20c and 24c respectively slide over the movable and fixed base plate 24a and 20a. Thereby, sliding surfaces abrade to produce abrasion powder. The abrasion powder is mixed in the compressed air and is sent to the filter chamber 44 through the discharge port 20d and the communication hole 41c. When the discharged air passes through the filter 45 in the filter chamber 44, the filter 45 collects the abrasion powder in the discharged air and the discharged air is cooled substantially at the same time. Namely, as the abrasion powder is removed from the discharged air in the filter chamber 44 by the filter 45, the cooling water in the cooling chamber 32 cools the discharged air. The filtered air having a low temperature is outputted to the outside or an external circuit of the compressor 10 from the outlet 41d.

[0027] In the first preferred embodiment, following effects are obtained. As described above, in the present preferred embodiment, the filter chamber 44 accommodating the filter 45 is formed in the compressor 10 and is adjacent to the cooling chamber 32. Accordingly, since cleaning and cooling of the discharged air are simultaneously conducted in one space, the space is efficiently and logically utilized. Also, since the cooling chamber 32 is adjacent to the compression chambers 26, cooling action is applied to the compressed air in the compression chambers 26 and the filter chamber 44. Accordingly, the compressed air is effectively cooled.

[0028] Also, in the present preferred embodiment, the

filter chamber 44 is formed in the compressor 10. In this regard, a conduit in the external circuit is generally not large enough in diameter for efficient circulation. A filter area size is limited to a small cross-sectional area of the conduit in the external circuit. No significant limitation is applicable for the cross-sectional size in the present preferred embodiment since the filter is in the compressor. The filter 45 is enlarged in the preferred embodiment in an orthogonal direction relative to the compressed air flow direction in which the compressed air flows in the filter chamber 44. Based on this design, the area of the filter 45 is substantially larger than that in the external circuit, and the capacity for collecting the foreign substances is also substantially enhanced. Consequently, since a flow rate of the air is reduced due to the large area, cooling time of the compressed air in the filter chamber 44 is longer, and a strong cooling effect is obtained.

[0029] In the present preferred embodiment, the cooling chamber 32 is formed between the compression chambers 26 and the filter chamber 44. The heat is exchanged between the cooling water in the cooling chamber 32 and the compressed air to cool the compressed air in the compression chambers 26 and the filter chamber 44. Therefore, in comparison to cooling the compressed air only in the filter chamber 44, the cooling effect on the air is further enhanced.

[0030] In the present preferred embodiment, the filter casing 41 has the two-part structure including the inner and outer casings 41a and 41b. The inner casing 41a is fixed to the fixed scroll member 20, and the outer casing 41b is detachably fixed to the inner casing 41a. Since the outer casing 41b is detached from the inner casing 41a as necessary, the filter 45 in the filter chamber 44 is easily replaced or cleaned. Also, the filter casing 41 is connected to the fixed scroll member 20 so as to provide the filter chamber 44. To an existing compressor, a filter casing is newly placed to a housing so that a filter chamber is newly provided for the existing compressor. Therefore, the above simple design change enables the existing scroll type electric compressor to cool air and remove foreign substances.

[0031] A plurality of the flow-dividing fins 33 is provided in the cooling chamber 32 and protrudes from the fixed base plate 20a of the fixed scroll member 20. The flow-dividing fins 33 contact the inner casing 41a. Thus, a heat transfer area between the cooling chamber 32 and the compression chambers 26 as well as between cooling chamber 32 and the filter chamber 44 is increased. Consequently, the cooling effect is enhanced.

[0032] A second preferred embodiment will be now described in reference to FIGS. 4 and 5. Since the second preferred embodiment is modified from the above-described first preferred embodiment, only the modified parts will be described, and the same description will be omitted. FIG. 4 is a partially enlarged cross-sectional view of a scroll type compressor according to the second preferred embodiment of the present invention. As

shown in FIG. 4, in the present preferred embodiment, an additional filter 55 is added in the filter chamber 44 on an upstream side, that is, a rear side as indicated in the right in FIG 4 relative to the filter 45 of the above-described first preferred embodiment. The two filters 45 and 55 are located along the compressed air flow direction. For the convenience of the description, the filter 55 located at the upstream side and the filter 45 located at a downstream side or the front side are respectively referred to as a first filter and a second filter. Since the second filter 45 has substantially the same structure as in the first preferred embodiment, the description for the second filter 45 is omitted.

[0033] As schematically shown in FIG. 5, the first filter 55 includes a filter portion 55a for removing the foreign substances and a frame 55b arranged around the edges of the filter portion 55a for supporting the filter portion 55a. The frame 55b preferably includes a rib 55c for reinforcing. In order to enhance the capacity for collecting the foreign substances and the cooling effect, the filter portion 55a is preferably a pleated type filter element that a flat stainless screen is bent in zigzags as similarly done to the filter portion 45a of the second filter 45 as described with respect to FIG. 3. In addition to the stainless filter element, filter elements made of material such as steel, aluminum alloy, resin and fabric are also used for either of the first and second filter portions 55a and 45a. The first and second filter portions 55a and 45a have a micro structure or a mesh in which circular or square pores are formed in a plate material.

[0034] A plurality of mounting portions or first filter mounting portions 55d is formed at the periphery of the frame 55b. Two mounting portions 55d are shown in FIG. 5. The end portions of the mounting portions 55d are outwardly bent. The end portion of each mounting portion 55d is fixed to an inner surface of the inner casing 41a by a bolt 57 so that the first filter 55 is supported in the filter chamber 44 as shown in FIG. 4. Thereby, the filter portion 55a of the first filter 55 is supported in the filter chamber 44. Also, an escape passage 56 bypasses the first filter 55 and leads to the second filter 45. The first and second filters 55 and 45 are placed at a predetermined interval along the compressed air flow direction or a horizontal direction in FIG. 4. The first and second filters 55 and 45 are both located so as to face the discharge port 20d. Namely, the first and second filters 55 and 45 are located so as to be perpendicular to the compressed air flow direction in the filter chamber 44.

[0035] In general, a mesh size M1 of the first filter 55 and a mesh size M2 of the second filter 45 preferably satisfy the following inequality. The mesh size is determined by the number of mesh openings in a square inch.

$$M1 \leq M2$$

[0036] In the present preferred embodiment, the mesh size M1 and M2 of the first and second filters 55 and 45 satisfy the following inequality:

$$M1 < M2$$

[0037] Namely, the mesh size M1 of the first filter 55

is smaller than the mesh size M2 of the second filter 45. More precisely, the mesh size of the first filter portion 55a in the first filter 55 ranges from 25 to 40 while the mesh size of the second filter portion 45a in the second filter 45 is approximately 100.

[0038] In general, a receiving area A1 of the filter portion 55a and a receiving area A2 of the filter portion 45a preferably satisfy the following inequality. The receiving area of the filter in the present specification means the area of the filter portion that receives the compressed air.

$$A1 \leq A2$$

[0039] In the preferred embodiment, the receiving areas A1 and A2 of the first and second filters 55 and 45 satisfy the following inequality:

$$A1 < A2$$

[0040] Namely, the receiving area A1 of the first filter 55 on the upstream side is smaller than the receiving area A2 of the second filter 45 on the downstream side.

[0041] According to the above scroll compressor 10 as shown in FIG.4, while the compressor 10 is operated, the compressed air is discharged from the discharge port 20d and is sent to the filter chamber 44 through the communication hole 41c. The compressed air passes through the first and second filters 55 and 45 in this order. Therefore, the foreign substances such as the abrasion powder mixed in the compressed air are collected by the first and second filters 55 and 45, and the compressed air is cooled by the cooling water in the cooling chamber 32. Then, the filtered compressed air at a lower temperature is outputted from the outlet 45d to the external circuit of the compressor 10.

[0042] According to the scroll compressor 10 of the second preferred embodiment as constructed above, substantially the same advantageous effects are obtained as described in the first preferred embodiment.

[0043] Furthermore, the foreign substances such as the abrasion powder mixed in the compressed air are collected by the first and second filters 55 and 45 in a sequential manner so that the compressed air is cleaned through two filters over a longer period of time. Also, as the air flowing in the filter chamber 44 passes through the two filters 55 and 45, the flow rate of the air is further reduced. Therefore, the compressed air is effectively cooled. The escape passage 56 is formed so that the compressed air bypasses the first filter 55. The escape passage 56 includes the space between the first filter 55 and the inner casing 41 a as indicated by "X" in FIG. 5. If the first filter 55 is clogged, the compressed air bypasses the first filter 55 through the escape passage 56. Consequently, the pressure loss due to the clogged filter is prevented or reduced. Even though the first filter 55 is clogged, the compressor 10 effectively performs. In this regard, life of the scroll compressor 10 is extended. As described above, not only the foreign substances such as the abrasion powder mixed in the compressed air are substantially collected but also the temperature is substantially lower in the compressed air

that is discharged from the outlet 41d of the filter chamber 44.

[0044] Also, the escape passage 56 are formed so as to bypass the first filter 55 that is located on the upstream side. Thus, even though the compressed air bypasses the first filter 55, the foreign substances in the compressed air are eventually collected by the second filter 45 on the downstream side. Consequently, the foreign substances such as the abrasion powder mixed in the compressed air are effectively collected. Also, if the second filter 45 is clogged, the first and second filters 55 and 45 are replaced or cleaned. Without replacement or cleaning, the amount of clogged material on the second filter 45 is one indication of remaining life of the compressor 10.

[0045] The first and second filters 55 and 45 are located so as to face the discharge port 20d. Thus, the compressed air discharged from the discharge port 20d effectively passes through the two filters 55 and 45. Consequently, the foreign substances such as the abrasion powder mixed in the compressed air are effectively collected. Also, the two filters 55 and 45 are compactly installed in the compressor 10.

[0046] The mesh size M1 of the first filter 55 is smaller than the mesh size M2 of the second filter 45. Thus, the foreign substances such as the abrasion powder mixed in the compressed air are collected separately according to the size through the first filter 55 on the upstream side and then the second filter 45 on the downstream side.

[0047] The receiving area A1 of the first filter 55 on the upstream side is smaller than the receiving area A2 of the second filter 45 on the downstream side. Thus, the compressed air smoothly flows toward the second filter 45 on the downstream side after passing through the first filter 55 on the upstream side so that the foreign substances such as the abrasion powder mixed in the compressed air are effectively collected.

[0048] The second filter 45 is located on the downstream side with respect to first filter 55, and an escape passage is not formed at the second filter 45. Thus, since the compressed air cannot bypass the second filter 45, the foreign substances in the compressed air are eventually collected by the second filter 45. It is possible to avoid the flow of the foreign substances to the external circuit of the compressor 10 due to the insufficient cleaning which is expected when the compressed air supposedly bypasses the second filter 45.

[0049] The present invention is not limited to the above-described preferred embodiments, and the above-described preferred embodiments are also modified according to the present invention in the following manners.

[0050] The shapes of the first and second filters 55 and 45 are circular in the above-described preferred embodiments. However, the outer shapes of the first and second filters 55 and 45 are changed. For example, in a first alternative embodiment, the shape of at least one

of the first and second filters 55 and 45 is substantially rectangular as shown in FIG. 6. In a second alternative embodiment, the shape of at least one of the first and second filters 55 and 45 is substantially semicircular as shown in FIG. 7.

[0051] As shown in FIG. 8, the filter 55 or 45 has a substantially rectangular shape, and the shape of the filter portion 55a or 45a is different from the shape of the frame 55b or 45b in a third alternative embodiment. In this case, the filter portion 55a or 45a avoids holes H1 for inserting bolts and a hole H2 that leads to the coolant inlet 32a or the coolant outlet 32b of the cooling chamber 32 as shown in FIG 2, which are formed in the frame 55b or 45b. Namely, the shape of the filter portion 55a or 45a is appropriately changed in accordance with the design requirements including the location for inserting bolts, the location for the coolant inlet 32a and the coolant outlet 32b of the cooling chamber 32, and the location for the communication hole 41c and the outlet 41d of the filter chamber 44 in the filter casing 41.

[0052] The first and second filters 55 and 45 have planar shapes in the above-described preferred embodiment. However, in a fourth alternative embodiment, the first and second filters 55 and 45 have substantially hemispherical shapes as shown in FIG. 9. The first filter 55 is connected to the inner casing 41a of the filter casing 41 in the above-described second preferred embodiment. However, as shown in FIG. 10, the first filter 55 is connected to the frame 45b of the second filter 45 in a fifth alternative embodiment. In this case, the end portion of each mounting portion 55d of the frame 55b of the first filter 55 is similarly fixed to the frame 45b of the second filter 45 by a bolt that is not shown in the drawings as the above description. Thereby, the filter portion 55a of the first filter 55 is suspended in the filter chamber 44, and a part of the escape passage 56 is formed between the frame 55b of the first filter 55 and the inner casing 41a.

[0053] As shown in FIG. 11, the frame 45b of the second filter 45 and the frame 55b of the first filter 55 are sandwiched between the inner and outer casings 41a and 41b in a sixth alternative embodiment. Thereby, the frame 45b of the second filter 45 and the frame 55b of the first filter 55 are supported. A ring-shaped spacer 50 is interposed between the first filter frame 55b and the second filter frame 45b. Therefore, an interval is maintained between the first and second filters 55 and 45. In this case, an escape passage 56 includes through holes that are formed in the first filter frame 55b. Meanwhile, the spacer 50 is formed integrally with either of the first filter frame 55b or the second filter frame 45b, and the number of components is reduced.

[0054] As shown in FIG. 12, an escape passage 56 at the first filter 55 is formed so as to be opened and closed by an open-close means in a seventh alternative embodiment. The open-close means closes the escape passage 56 when the compressed air pressure on the upstream side relative to the first filter 55 is smaller than

a predetermined pressure. The open-close means opens the escape passage 56 when the compressed air pressure on the upstream side relative to the first filter 55 is equal to or larger than the predetermined pressure. Namely, a support member 58 is arranged at the inner casing 41a. The support member 58 includes a fixed support portion 58a that has a ring shape and a plurality of movable support portions 58b that extends from the fixed support portion 58a. The fixed support portion 58a is fixed to the inner casing 41a. The end portions of the movable support portions 58b movably support the first filter frame 55b in an axial direction as shown in a horizontal direction in FIG. 12. The movable support portions 58b are arranged in a circumferential direction of the support member 58. Therefore, a part of the escape passage 56 is formed between the movable support portions 58b. The first filter frame 55b contacts the fixed support portion 58a to close the escape passage 56 as shown by a solid line in FIG. 12. The first filter frame 55b separates itself from the fixed support portion 58a to open the escape passage 56 as shown by a double-dotted line in FIG. 12. Furthermore, an elastic member 59 such as a coil spring is interposed between the first filter frame 55b and the movable support portions 58b for urging the first filter 55 in a direction in which the escape passage 56 are closed or rightward in FIG. 12. That is, the direction is to urge the first filter 55 to close the escape passage 56. The first filter 55, the support member 58 and the elastic member 59 constitute an open-close means of the present invention.

[0055] As constructed above, the first filter 55 is urged by the elastic member 59 to close the escape passage 56 when the first filter 55 is at a position as shown by the solid line in FIG. 12. Thereby, the compressed air discharged from the discharge port 20d through the communication hole 41c passes through the first filter 55. Consequently, the foreign substances such as the abrasion powder mixed in the compressed air are effectively collected by the first filter 55.

[0056] Also, when the first filter 55 is clogged and the compressed air pressure on the upstream side relative to the first filter 55 is equal to or more than the predetermined pressure, the first filter 55 is forced to move against the urging of the elastic member 59 to open the escape passage 56 at a position as shown by the double-dotted line in FIG. 12. Thereby, the compressed air bypasses the first filter 55 through the opened escape passage 56. Consequently, the pressure loss due to the clogging of the first filter 55 is substantially prevented or reduced. As described above, even though the first filter 55 is clogged, the compressor 10 effectively performs without cleaning or replacing the clogged filter 55. Thus, the life of the scroll compressor 10 is extended beyond the point when the first filter 55 is clogged.

[0057] Since the first filter 55, the support member 58 and the elastic member 59 constitute the open-close means according to the present invention as described above, the first filter 55 effectively functions as a valve

body. Meanwhile, instead of the above open-close means, another alternative embodiment utilizes a known escape valve at an escape passage in the filter casing 41 for bypassing the first filter 55.

[0058] Also, in an eighth alternative embodiment, in the second filter 45, an escape passage is similarly formed so as to be opened and closed by an open-close means as in the above first filter 55. The open-close means usually closes the escape passage while the open-close means opens the escape passage when the pressure of the compressed air on the upstream side relative to the second filter 45 is equal to or larger than a predetermined pressure.

[0059] The recess 32c is formed in the fixed base plate 20a of the fixed scroll member 20 for defining the cooling chamber 32 in the above-described preferred embodiments. However, in a ninth alternative embodiment, the recess 32c is formed in the inner casing 41a of the filter casing 41, or in both the fixed base plate 20a and the inner casing 41a.

[0060] Also, in a tenth alternative embodiment, an additional cooling chamber is defined on the front side of the filter casing 41 for cooling the discharged air in the filter chamber 44 from both the front side and the rear side of the filter chamber 44.

[0061] The flow-dividing fins 33 are formed in the cooling chamber 32. However, in an eleventh alternative embodiment, the flow-dividing fins 33 are formed on the rear side of the inner casing 41a of the filter casing 41, or are omitted.

[0062] The above-described preferred embodiments apply to the compressor for compressing the gas, more particularly the air, which is supplied to the fuel cell FC of the electric vehicle. However, in a twelfth alternative embodiment, the present invention is applied to a compressor in an air conditioner or a refrigerating device.

[0063] The two filters 55 and 45 in the second preferred embodiment are located. However, in a thirteenth alternative embodiment, three filters or more are located along the flow direction of the gas. An escape passage is formed so as to bypass at least one of the filters. Also, the first and second filters 55 and 45 are located so as to be offset from the discharge port 20d and do not face the discharge port 20d.

[0064] In the above-mentioned preferred embodiments, the present invention is applied to a scroll type compressor. However, the present invention is also applied to other type compressors.

[0065] The present examples and embodiments are to be considered as illustrative and not restrictive, and the invention is not to be limited to the details given herein but may be modified within the scope of the appended claims.

[0066] A scroll type compressor includes a fixed scroll member and a movable scroll member to define compression chambers. The movable scroll member orbits relative to the fixed scroll member to compress gas in the compression chambers. The compressed gas is dis-

charged to a discharge port. The compressor also includes a filter chamber and a cooling chamber. The filter chamber communicates with the discharge port for accommodating a first filter to at least partially filter the compressed gas. The cooling chamber is located adjacent to the filter chamber for containing coolant fluid that cools the compressed gas in the filter chamber.

Claims

1. A compressor (10) for compressing gas, **characterized in that** a filter chamber (44) is provided for accommodating a first filter (55) so as to at least partially filter the compressed gas, and **in that** a cooling chamber (32) is located adjacent to the filter chamber (44) for containing coolant fluid so that cooling temperature of the coolant fluid is transmitted to the filter chamber (44).
2. The compressor (10) according to claim 1, **characterized in that** compression chambers (26) are located adjacent to the cooling chamber (32) for compressing the gas so that the cooling temperature of the coolant fluid is transmitted to the compression chambers (26).
3. The compressor (10) according to claim 1, **characterized in that** a fixed scroll member (20) and a movable scroll member (24) define compression chambers (26), the movable scroll member (24) orbiting relative to the fixed scroll member (20) to compress the gas in the compression chambers (26), a discharge port (20d) being provided for discharging the compressed gas from the compression chambers (26) and communicating with the filter chamber (44).
4. The compressor (10) according to claim 2 or 3, wherein the cooling chamber (32) is located between the compression chambers (26) and the filter chamber (44).
5. The compressor (10) according to claim 3 or 4, **characterized in that** an inner casing (41a) and an outer casing (41b) define the filter chamber (44), the inner casing (41a) being fixed to the fixed scroll member (20), the outer casing (41b) being detachably fixed to the inner casing (41a).
6. The compressor (10) according to claim 5, wherein the first filter (55) is supported in such a manner that the first filter (55) is sandwiched by the inner and outer casings (41a, 41b).
7. The compressor (10) according to any one of claims 3 through 6, wherein the first filter (55) is located so as to be perpendicular to a first flow direction in

which the compressed gas flows in the filter chamber (44), the first flow direction being substantially the same as a second flow direction in which the compressed gas flows in the discharge port (20d).

8. The compressor (10) according to any one of claims 3 through 7, wherein the filter chamber (44) further accommodates a second filter (45), the first and second filters (45, 55) being located along a first flow direction in which the compressed gas flows in the filter chamber (44), an escape passage (56) being formed in such a manner that the compressed gas bypasses at least one of the first and second filters (45, 55).
9. The compressor (10) according to claim 8, wherein the compressed gas flows in the discharge port (20d) in a second flow direction that is substantially the same as the first flow direction.
10. The compressor (10) according to claim 8 or 9, wherein the first and second filters (45, 55) are located so as to be perpendicular to the first flow direction.
11. The compressor (10) according to any one of claims 8 through 10, wherein the compressor (10) is a scroll type compressor, and wherein the first filter (55) is located on an upstream side with respect to the second filter (45), each of the first and second filters (45, 55) having a mesh, a mesh size (M2) of the second filter (45) being equal to or larger than that (M1) of the first filter (55).
12. The compressor (10) according to any one of claims 8 through 11, wherein the first filter (55) is located on an upstream side with respect to the second filter (45), the first filter (55) having a first predetermined receiving area (A1), the second filter (45) having a second predetermined receiving area (A2) that is equal to or larger than the first predetermined receiving area (A1).
13. The compressor (10) according to any one of claims 8 through 12, **characterized in that** an open-close means is provided for closing the escape passage (56) when a pressure of the compressed gas on an upstream side of the escape passage (56) is lower than a predetermined pressure, the open-close means opening the escape passage (56) when the pressure of the compressed gas on the upstream side of the escape passage (56) is equal to or larger than the predetermined pressure.
14. The compressor (10) according to claim 13, wherein the open-close means further comprises a fixed support portion (58a) that is fixed to the inner casing (41a) and a movable support portion (58b) for mov-

- ably supporting the first filter (55), the first filter (55) contacting the fixed support portion (58a) so as to close the escape passage (56), the first filter (55) moving away from the fixed support portion (58a) so as to open the escape passage (56).
15. The compressor (10) according to claim 14, wherein the open-close means further comprises an elastic member (59) for urging the first filter (55) to close the escape passage (56). 5
16. The compressor (10) according to any one of claims 8 through 15, wherein the second filter (45) is located on a downstream side with respect to the first filter (55), the escape passage (56) being formed in such a manner that the compressed gas bypasses the first filter (55). 10
17. The compressor (10) according to any one of claims 8 through 16, wherein the second filter (45) is located on a downstream side with respect to the first filter (55), the compressed gas passing through the second filter (45) without bypassing the second filter (45). 15
18. The compressor (10) according to any one of claims 8 through 17, wherein the first and second filters (45, 55) are supported in such a manner that the first and second filters (45, 55) are sandwiched between the inner and outer casings (41a, 41b). 20
19. The compressor (10) according to any one of claims 8 through 18, **characterized in that** a first filter mounting portion (55d) is provided for placing the first filter (55) adjacent to the second filter (45) at a predetermined distance from the second filter (45). 25
20. The compressor (10) according to claim 19, wherein the first filter mounting portion (55d) is connected to the inner casing (41a). 30
21. The compressor (10) according to claim 19, wherein the second filter (45) has a frame (45b), the first filter mounting portion (55d) being connected to the frame (55b) of the second filter (45). 35
22. The compressor (10) according to any one of claims 1 through 21, wherein the first filter (55) further comprises a filter portion (55a) and a frame (55b). 40
23. The compressor (10) according to claim 22, wherein a shape of the filter portion (55a) is different from that of the frame (55b). 45
24. The compressor (10) according to claim 22 or 23, wherein the first filter (55) has a circular shape. 50
25. The compressor (10) according to claim 22 or 23, wherein the first filter (55) has a rectangular shape. 55
26. The compressor (10) according to claim 22 or 23, wherein the first filter (55) has a semicircular shape.
27. The compressor (10) according to any one of claims 22 through 26, wherein the first filter (55) has a planar shape.
28. The compressor (10) according to any one of claims 22 through 26, wherein the first filter (55) has a hemispherical shape.
29. The compressor (10) according to any one of claims 1 through 28, wherein flow-dividing fins (33) are provided in the cooling chamber (32) for dividing flow of the coolant fluid.
30. The compressor (10) according to any one of claims 3 through 29, **characterized in that** a suction port (20e) is provided for introducing the compressed gas into the compression chambers (26).
31. The compressor (10) according to any one of claims 3 through 30, wherein an inlet (41c) is formed at the filter chamber (44) for communicating with the discharge port (20d), an outlet (41d) being formed at the filter chamber (44) for leading the compressed gas to an external circuit.
32. A cooling circuit for cooling gas in a compressor (10) according to any one of claims 1 through 31, **characterized in that** a heat exchanger is connected to the cooling chamber (32) for cooling the coolant fluid from the cooling chamber (32), and **in that** a pump is connected to the heat exchanger for supplying the coolant fluid to the cooling chamber (32).
33. A method of processing compressed gas in a compressor (10) that forms a compression chambers (26) for compressing the gas, a filter chamber (44) having a filter (45) and a cooling chamber (32) that is located adjacent to the filter chamber (44) for containing coolant fluid, **characterized by:**
- transmitting cooling temperature of the coolant fluid to the filter chamber (44);
cooling the compressed gas in the filter chamber (44); and
removing foreign substances in the compressed gas through the filter (45) in the filter chamber (44) simultaneously with said cooling.
34. The method according to claim 33, **characterized by:**
- transmitting the cooling temperature of the coolant fluid to the compression chambers (26);

and
cooling the compressed gas in the compression chambers (26) simultaneously with said cooling the compressed gas in the filter chamber (44).

5

35. The method according to claim 33 or 34, wherein the compressor (10) is a scroll type compressor.

10

15

20

25

30

35

40

45

50

55

FIG. 1

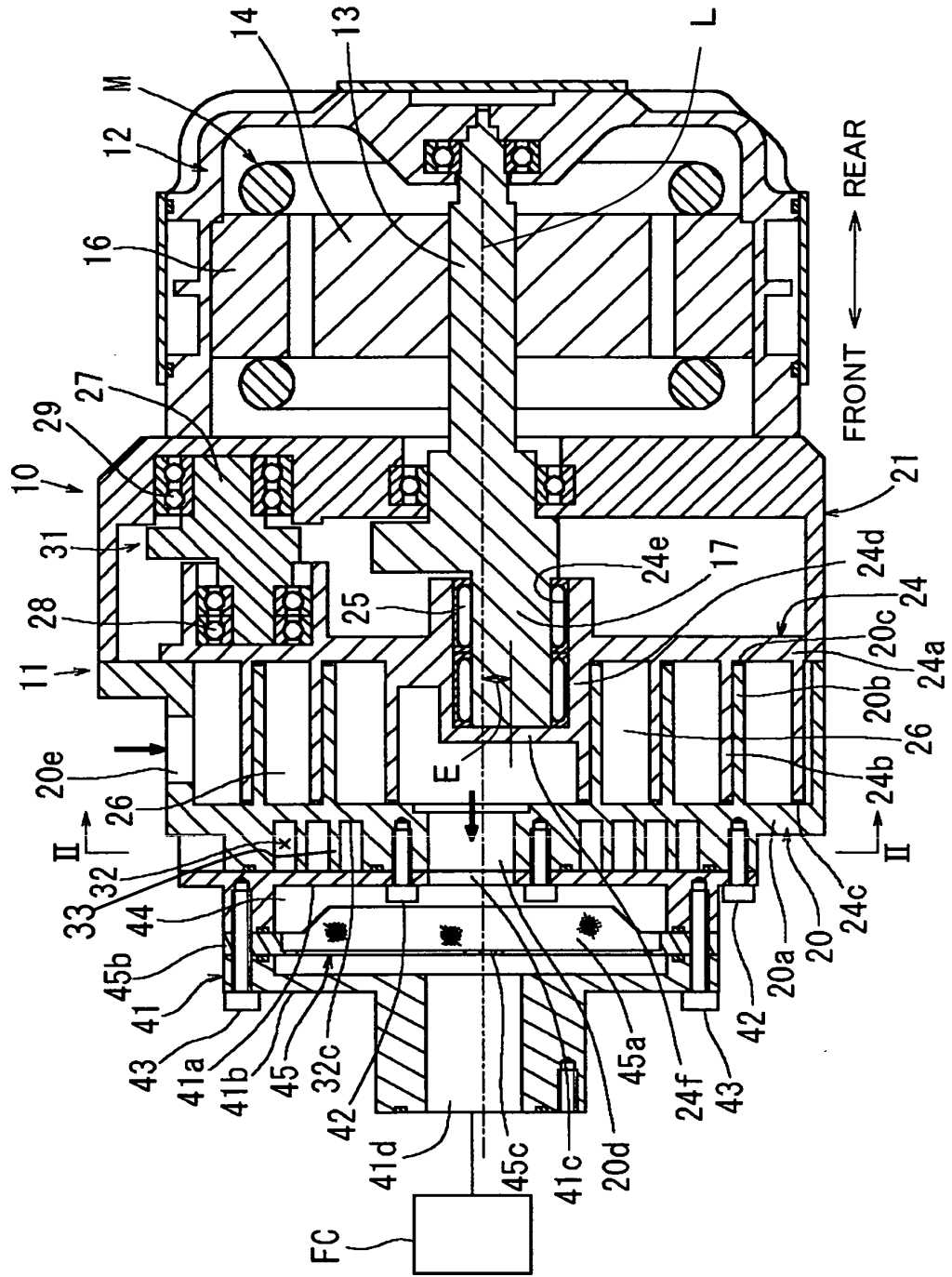

FIG. 2

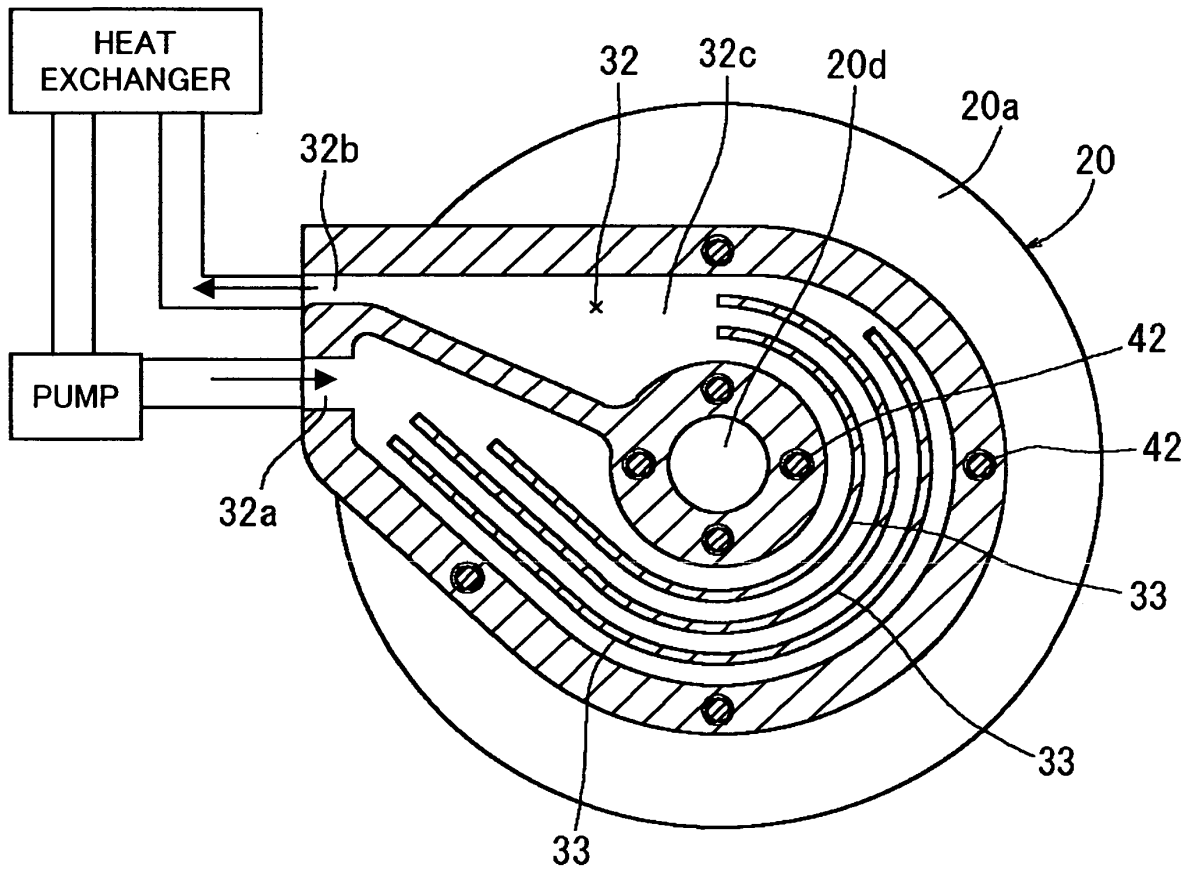

FIG. 3

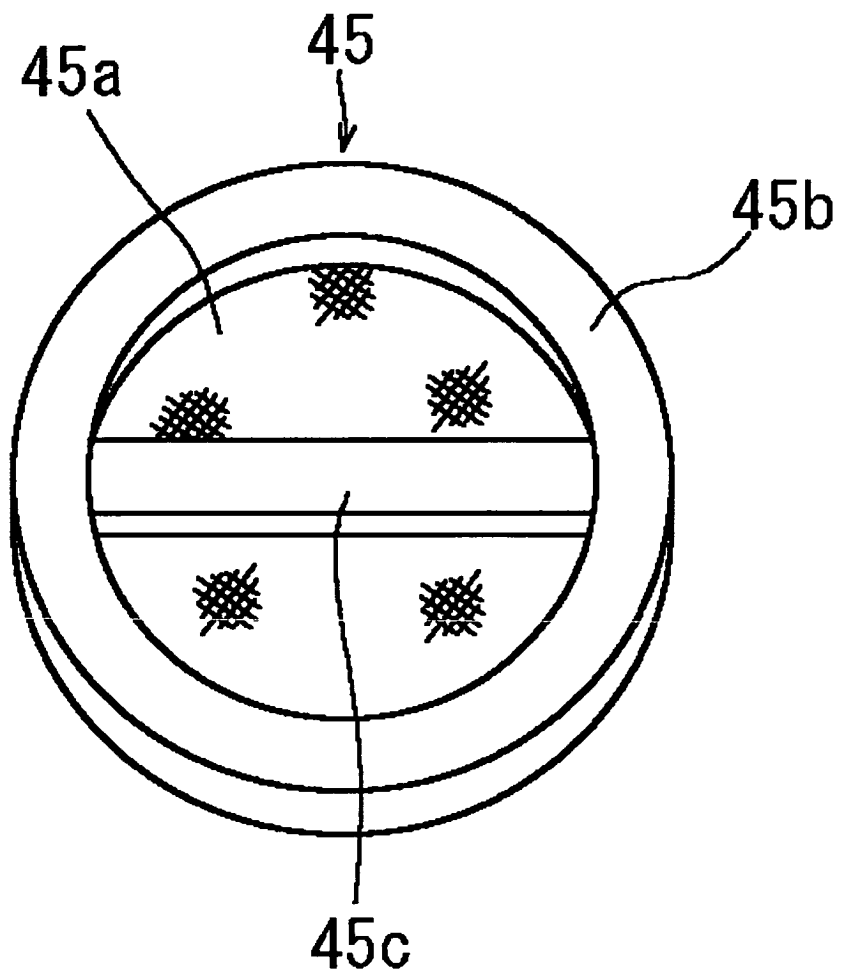

FIG. 4

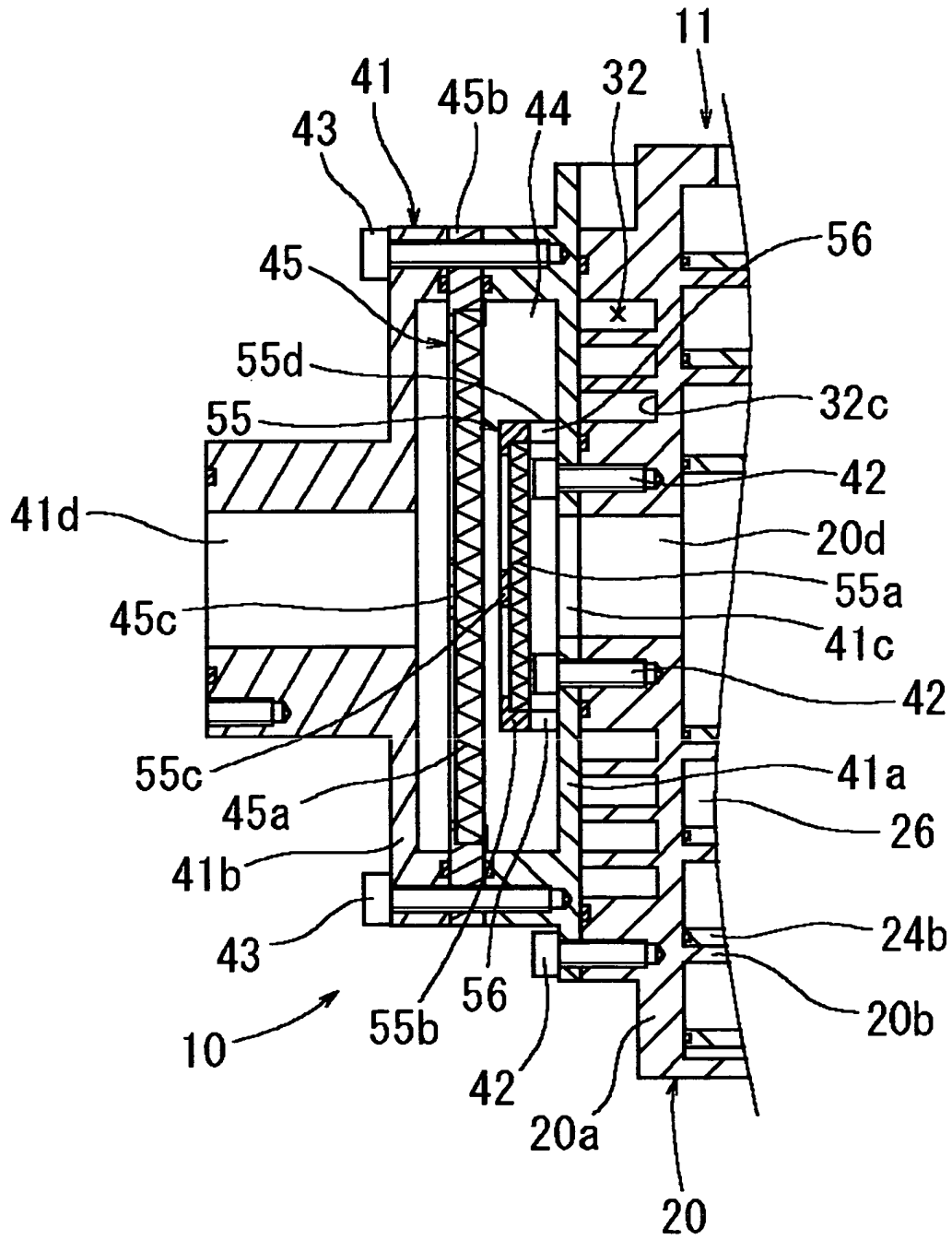

FIG. 5

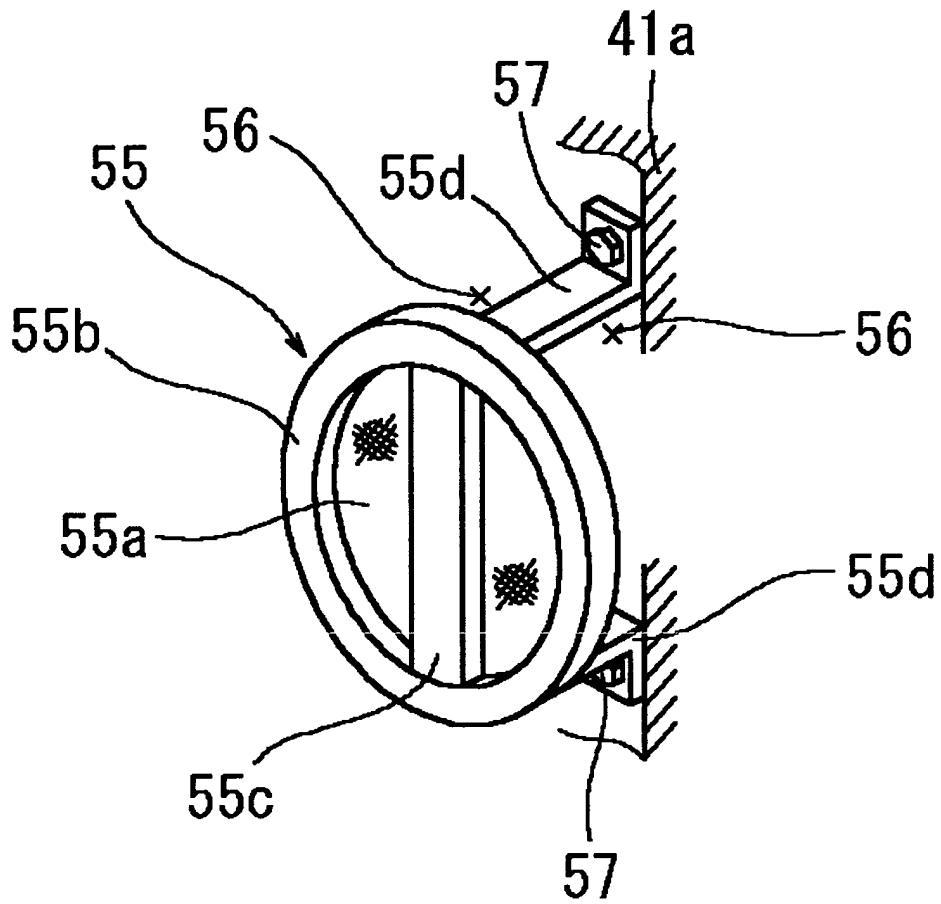

FIG. 6

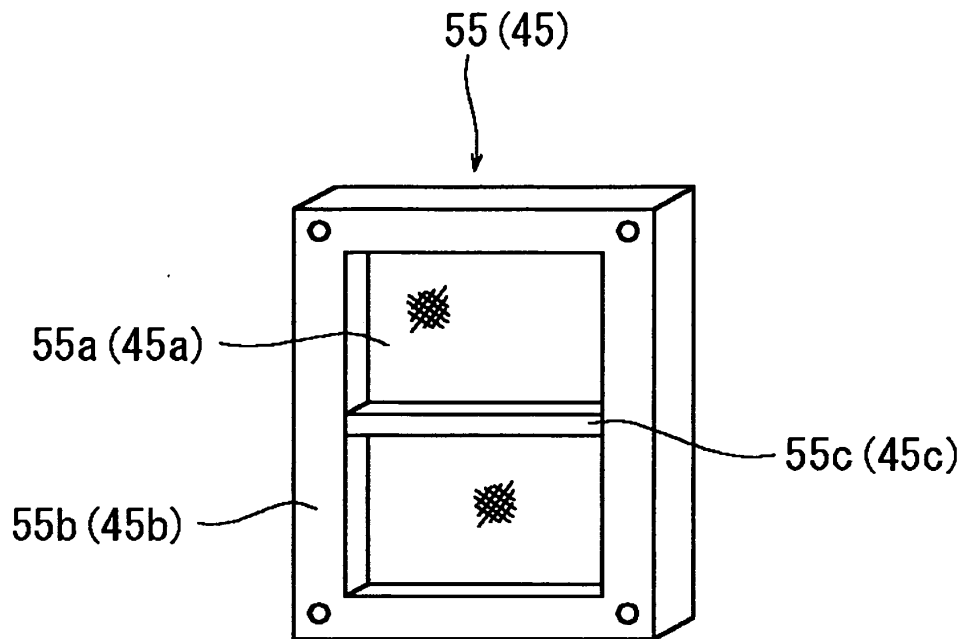

FIG. 7

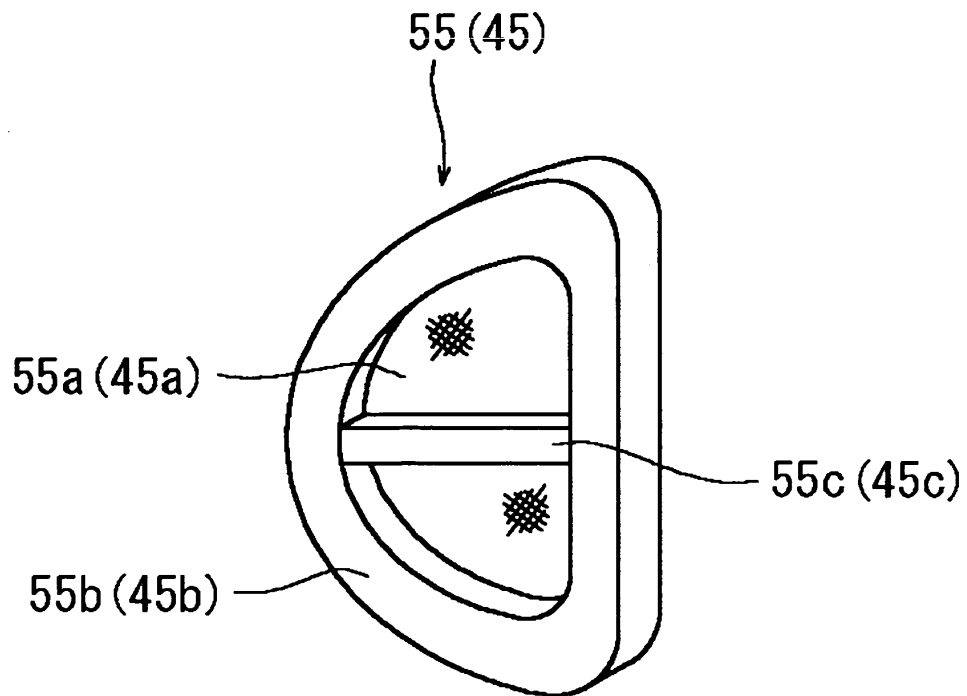

FIG. 8

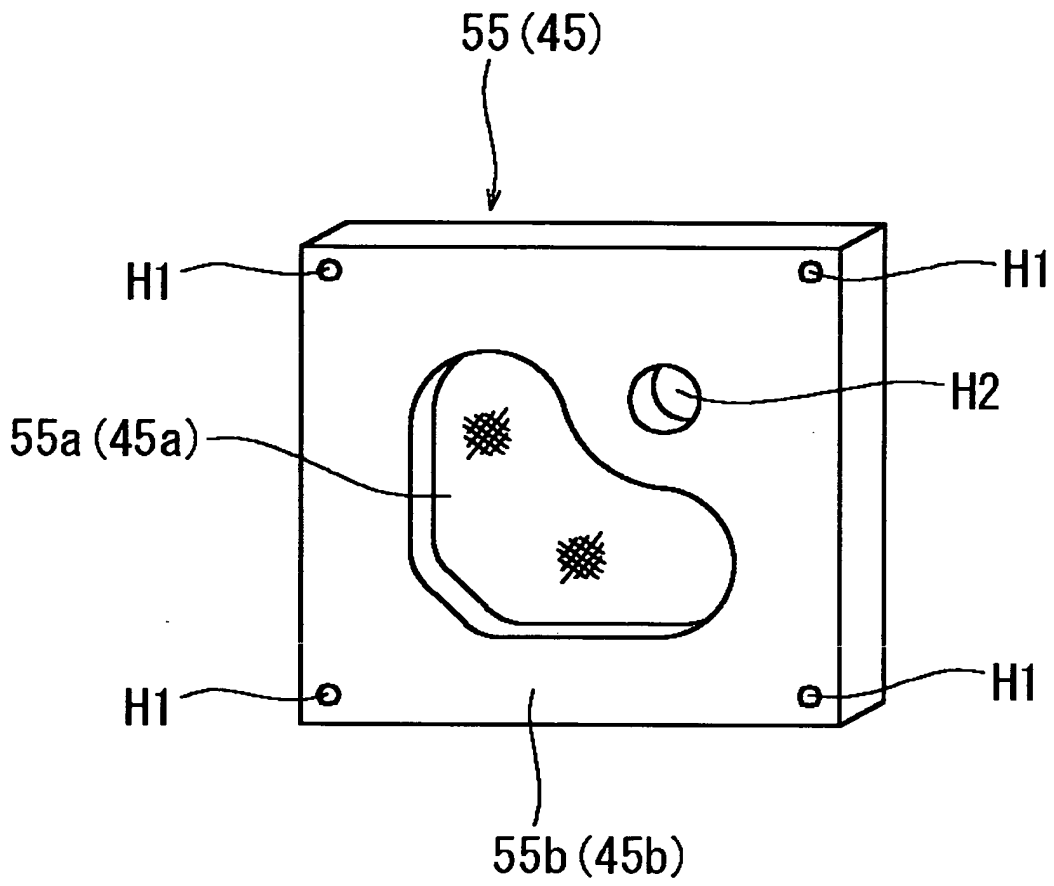

FIG. 9

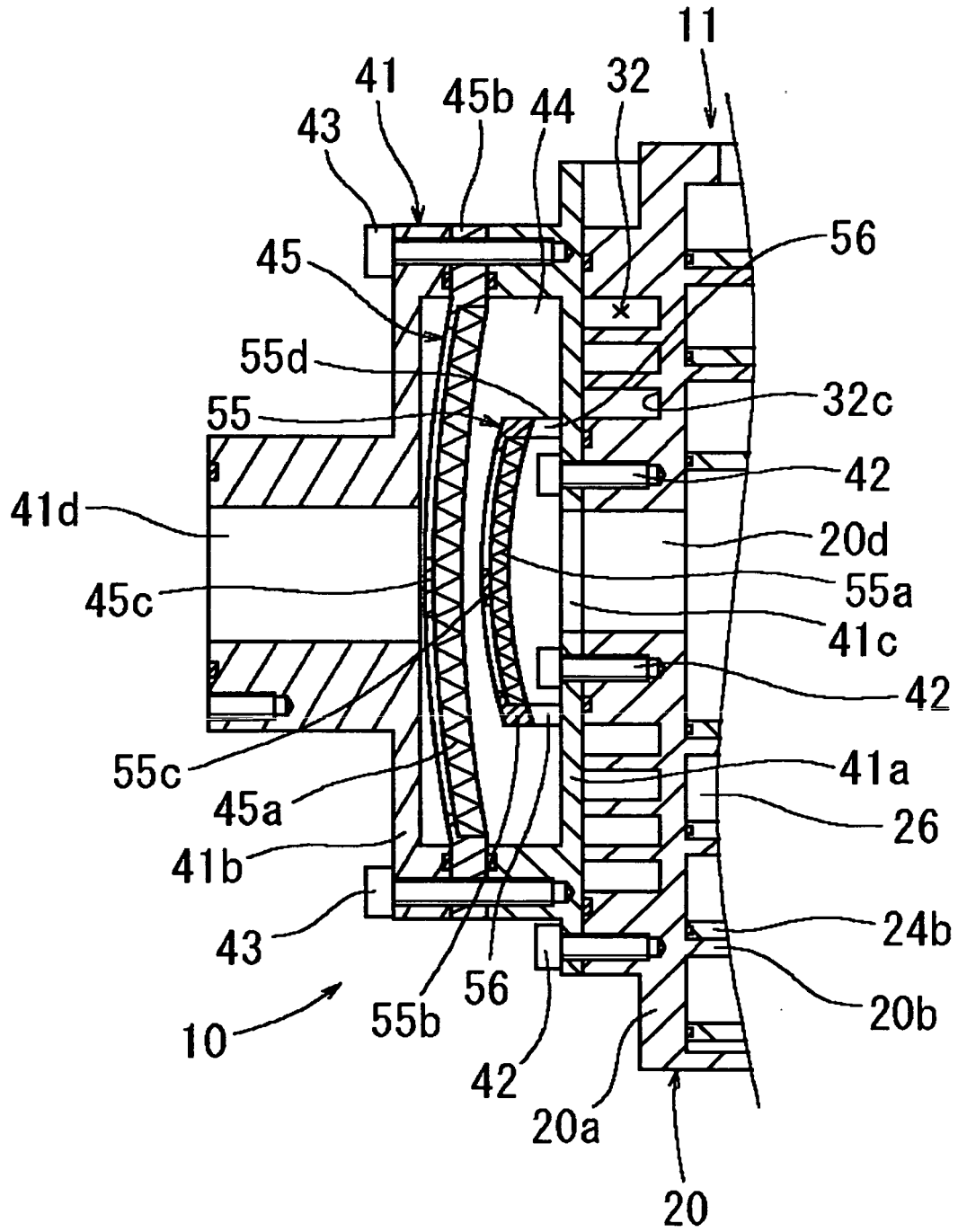

FIG. 10

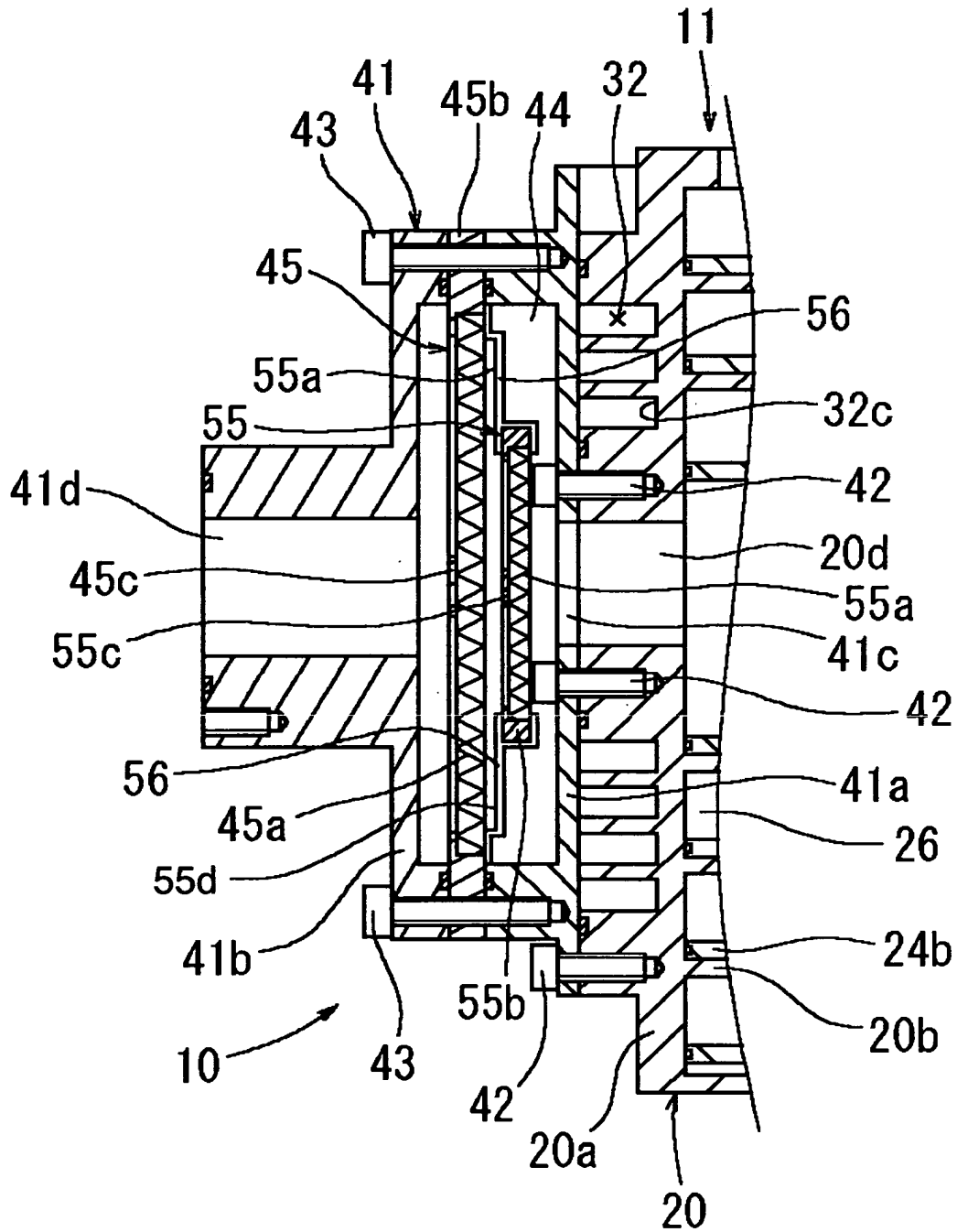

FIG. 11

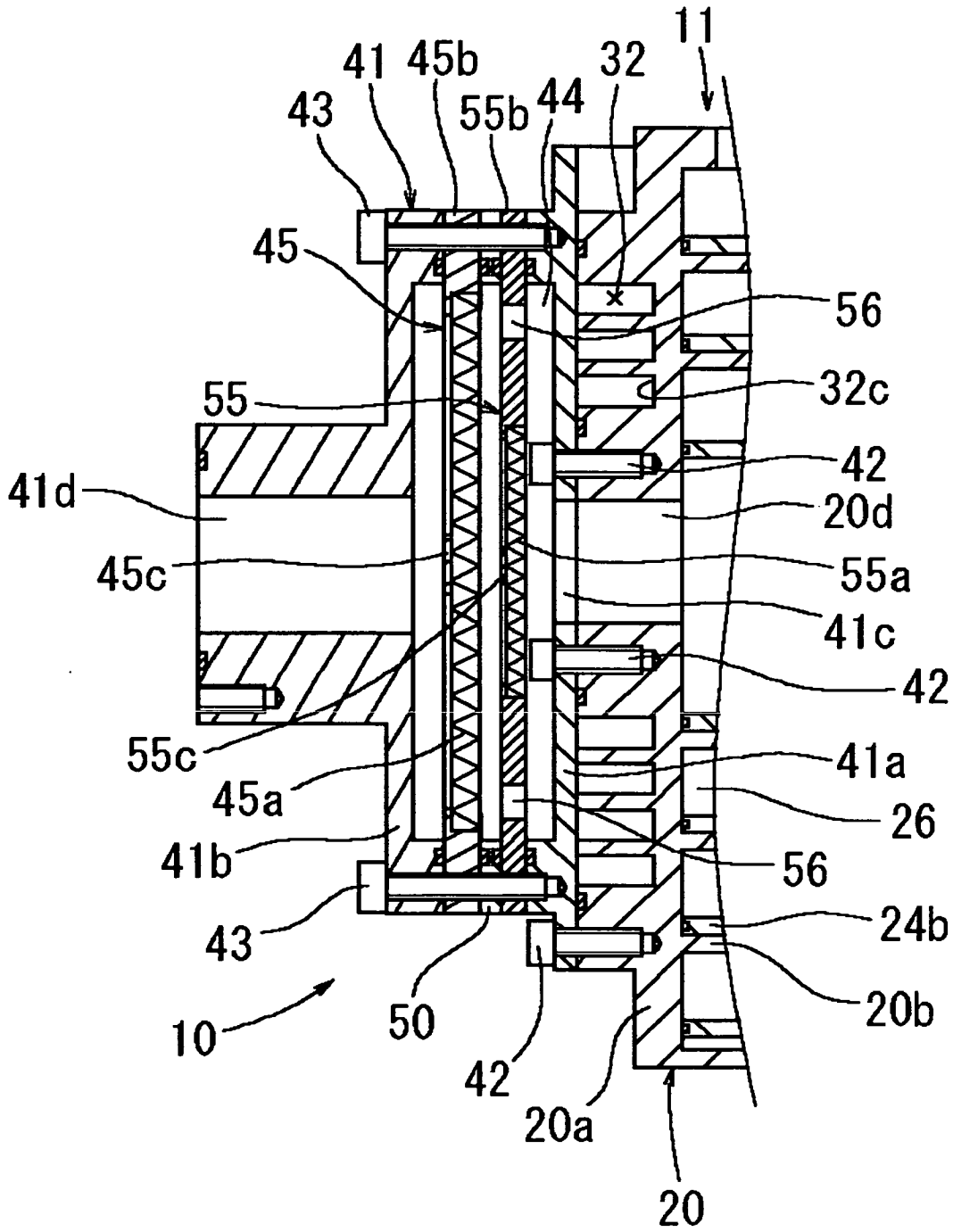
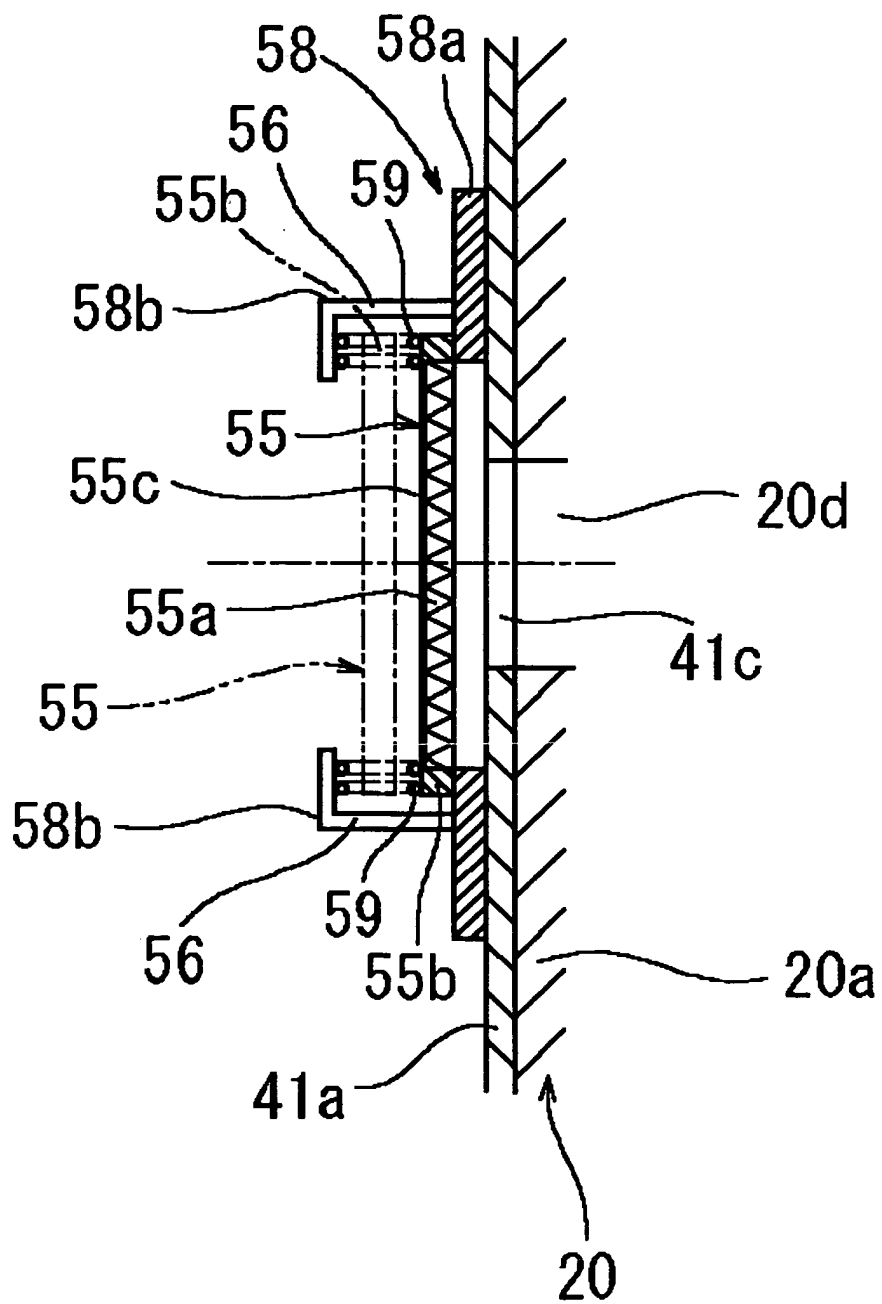

FIG. 12





European Patent
Office

EUROPEAN SEARCH REPORT

Application Number
EP 04 00 2443

DOCUMENTS CONSIDERED TO BE RELEVANT			
Category	Citation of document with indication, where appropriate, of relevant passages	Relevant to claim	CLASSIFICATION OF THE APPLICATION (Int.Cl.7)
P,X, L	EP 1 371 851 A (TOYOTA JIDOSHOKKI KK) 17 December 2003 (2003-12-17) * figure 1 * * column 4, line 20 - line 21 * * column 4, line 48 - column 5, line 5 * L: Priority -----	1-3,7, 29-31, 33-35	F04C29/00 F04C29/04
X	US 4 174 196 A (ARAI AKIRA ET AL) 13 November 1979 (1979-11-13) * figures 18,19 * * column 10, line 9 - column 11, line 6 * -----	1,2,4, 22-34	
A	EP 0 322 894 A (MATSUSHITA ELECTRIC IND CO LTD) 5 July 1989 (1989-07-05) * figure 15 * * column 23, line 53 - line 58 * -----	1	
A	US 5 775 888 A (HIDANO KATSUSHI ET AL) 7 July 1998 (1998-07-07) * figure 1 * * column 3, line 25 - column 4, line 5 * * column 5, line 19 - line 31 * -----	1	
			TECHNICAL FIELDS SEARCHED (Int.Cl.7)
			F04C F04B
The present search report has been drawn up for all claims			
Place of search		Date of completion of the search	Examiner
The Hague		7 May 2004	Lequeux, F
CATEGORY OF CITED DOCUMENTS			
X : particularly relevant if taken alone Y : particularly relevant if combined with another document of the same category A : technological background O : non-written disclosure P : intermediate document		T : theory or principle underlying the invention E : earlier patent document, but published on, or after the filing date D : document cited in the application L : document cited for other reasons ----- & : member of the same patent family, corresponding document	

EPO FORM 1503 03/02 (F04C01)

ANNEX TO THE EUROPEAN SEARCH REPORT
ON EUROPEAN PATENT APPLICATION NO.

EP 04 00 2443

This annex lists the patent family members relating to the patent documents cited in the above-mentioned European search report. The members are as contained in the European Patent Office EDP file on
The European Patent Office is in no way liable for these particulars which are merely given for the purpose of information.

07-05-2004

Patent document cited in search report		Publication date	Patent family member(s)	Publication date
EP 1371851	A	17-12-2003	JP 2004011605 A	15-01-2004
			EP 1371851 A2	17-12-2003
			US 2003228235 A1	11-12-2003
US 4174196	A	13-11-1979	JP 1277055 C	16-08-1985
			JP 53015610 A	13-02-1978
			JP 58048756 B	31-10-1983
			JP 53053009 A	15-05-1978
			JP 58048757 B	31-10-1983
			BE 857230 A1	14-11-1977
			DE 2733902 A1	02-02-1978
EP 0322894	A	05-07-1989	JP 2009971 A	12-01-1990
			JP 2012082 C	02-02-1996
			JP 7042943 B	15-05-1995
			JP 2006684 C	11-01-1996
			JP 2009978 A	12-01-1990
			JP 7039836 B	01-05-1995
			JP 1177482 A	13-07-1989
			JP 7117049 B	18-12-1995
			CA 1329183 C	03-05-1994
			DE 3888147 D1	07-04-1994
			DE 3888147 T2	22-09-1994
			EP 0322894 A2	05-07-1989
			KR 9508694 B1	04-08-1995
US 4958993 A	25-09-1990			
US 5775888	A	07-07-1998	JP 3424881 B2	07-07-2003
			JP 9068175 A	11-03-1997

EPO FORM P0459

For more details about this annex : see Official Journal of the European Patent Office, No. 12/82