

(12) STANDARD PATENT APPLICATION (11) Application No. AU 2023202867 A1
(19) AUSTRALIAN PATENT OFFICE

(54) Title
**COMPOSITIONS COMPRISING 2,3-DICHLORO-1,1,1-TRIFLUOROPROPANE, 2-
CHLORO-1,1,1-TRIFLUOROPROPENE, 2-CHLORO-1,1,1,2-TETRAFLUOROPROPANE
OR 2,3,3,3-TETRAFLUOROPROPENE**

(51) International Patent Classification(s)
C07C 17/25 (2006.01) **C09K 3/30** (2006.01)
C08J 9/14 (2006.01) **C09K 5/04** (2006.01)

(21) Application No: **2023202867** (22) Date of Filing: **2023.05.09**

(43) Publication Date: **2023.05.25**

(43) Publication Journal Date: **2023.05.25**

(62) Divisional of:
2021204987

(71) Applicant(s)
THE CHEMOURS COMPANY FC, LLC.

(72) Inventor(s)
NAPPA, Mario Joseph;MAHLER, Barry Asher

(74) Agent / Attorney
Houlihan Intellectual Property Pty Ltd, 832 High St, Kew East, VIC, 3102, AU

ABSTRACT

Disclosed are compositions comprising HCFC-243db, HCFO-1233xf, HCFC-244db and/or HFO-1234yf and at least one additional compound. For the composition comprising 1234yf, the additional compound is selected from the group consisting of HFO-1234ze, HFO-1243zf, HCFC-243db, HCFC-244db, HFC-245cb, HFC-245fa, HCFO-1233xf, HCFO-1233zd, HCFC-253fb, HCFC-234ab, HCFC-243fa, ethylene, HFC-23, CFC-13, HFC-143a, HFC-152a, HFC-236fa, HCO-1130, HCO-1130a, HFO-1336, HCFC-133a, HCFC-254fb, HCFC-1131, HFO-1141, HCFO-1242zf, HCFO-1223xd, HCFC-233ab, HCFC-226ba, and HFC-227ca. Compositions comprising HCFC-243db, HCFO-1233xf, and/or HCFC-244db are useful in processes to make HFO-1234yf. Compositions comprising HFO-1234yf are useful, among other uses, as heat transfer compositions for use in refrigeration, air-conditioning and heat pump systems.

TITLE

COMPOSITIONS COMPRISING 2,3-DICHLORO-1,1,1-
TRIFLUOROPROPANE, 2-CHLORO-1,1,1-TRIFLUOROPROPENE, 2-
CHLORO-1,1,1,2-TETRAFLUOROPROPANE OR 2,3,3,3-
5 TETRAFLUOROPROPENE

RELATED APPLICATIONS

The present Application is a Divisional Application from Australian
Patent Application No. 2021204987, which in turn is a Divisional
10 Application of Australian Patent Application No. 2019232793, which in turn
is a Divisional Application of Australian Patent Application No.
2018201724, which in turn is a Divisional Application of Australian Patent
Application No. 2016208263, which in turn is a Divisional Application of
Australian Patent Application No. 2014224160, which in turn is a Divisional
15 Application of Australian Patent No. 2009244265. The entire disclosures of
Australian Patent Application No. 2021204987, 2019232793, 2018201724,
2016208263, 2014224160, 2009244265, and its corresponding
International Patent Application No. PCT/US2009/043118 are incorporated
herein by reference. The Application Claims priority to US61/126,810 filed
20 on 7 May 2008, which is herein incorporated by reference in its entirety.

BACKGROUND

1. Field of the Invention.

The present disclosure relates to the field of compositions which
25 may be useful as heat transfer compositions, aerosol propellants, foaming
agents, blowing agents, solvents, cleaning agents, carrier fluids,
displacement drying agents, buffing abrasion agents, polymerization
media, expansion agents for polyolefins and polyurethane, gaseous
dielectrics, extinguishing agents, and fire suppression agents in liquid or
30 gaseous form. In particular, the present disclosure relates to compositions
which may be useful as heat transfer compositions, such as 2,3,3,3,-
tetrafluoropropene (HFO-1234yf, or 1234yf) or compositions comprising

2,3-dichloro-1,1,1-trifluoropropane (HCFC-243db or 243db), 2-chloro-1,1,1-trifluoropropene (HCFO-1233xf or 1233xf) or 2-chloro-1,1,1,2-tetrafluoropropane (HCFC-244bb).

5 2. Description of Related Art.

New environmental regulations have led to the need for new compositions for use in refrigeration, air-conditioning and heat pump apparatus. Low global warming potential compounds are of particular interest.

10 **SUMMARY OF THE INVENTION**

Applicants have found that in preparing such new low global warming potential compounds, such as 1234yf, that certain additional compounds are present in small amounts.

Therefore, in accordance with the present invention, there is
15 provided a composition comprising HFO-1234yf and at least one

2023202867 09 May 2023

additional compound selected from the group consisting of HFO-1234ze, HFO-1243zf, HCFC-243db, HCFC-244db, HFC-245cb, HFC-245fa, HCFO-1233xf, HCFO-1233zd, HCFC-253fb, HCFC-234ab, HCFC-243fa, ethylene, HFC-23, CFC-13, HFC-143a, HFC-152a, HFO-1243zf, HFC-
5 236fa, HCO-1130, HCO-1130a, HFO-1336, HCFC-133a, HCFC-254fb, HCFC-1131, HFC-1141, HCFO-1242zf, HCFO-1223xd, HCFC-233ab, HCFC-226ba, and HFC-227ca. The composition contains less than about 1 weight percent of the at least one additional compound.

Compositions comprising HCFC-243db, HCFO-1233xf, and/or
10 HCFC-244db are useful in processes to make HFO-1234yf. Therefore, compositions comprising 1234yf may contain some amount of HCFC-243db, HCFO-1233xf, and/or HCFC-244db, in addition to other compounds.

Therefore, in accordance with the present invention, there is
15 provided a composition comprising HCFC-243db and at least one additional compound selected from the group consisting of ethylene, HFC-23, CFC-13, HFC-143a, HFC-152a, HFO-1234yf, HFO-1243zf, HFC-236fa, HCO-1130, HCO-1130a, HFO-1234ze, HFO-1336, HCFC-244bb, HCFC-244db, HFC-245fa, HFC-245cb, HCFC-133a, HCFC-254fb, HCFC-
20 1131, HCFO-1233xf, HCFO-1233zd, HCFO-1242zf, HCFC-253fb, HCFO-1223xd, HCFC-233ab, HCFC-226ba, and HFC-227ca. The composition may contain anywhere from greater than zero weight percent to about 99 weight percent of HCFC-243db.

In addition, in accordance with the present invention, there is further
25 provided a composition comprising HCFO-1233xf and at least one additional compound selected from the group consisting of HCFO-1233zd, HCFO-1232xd, HCFO-1223xd, HCFC-253fb, HCFC-233ab, HFO-1234yf, HFO-1234ze, ethylene, HFC-23, CFC-13, HFC-143a, HFC-152a, HFO-1243zf, HFC-236fa, HCO-1130, HCO-1130a, HFO-1336, HCFC-244bb, HCFC-244db, HFC-245fa, HFC-245cb, HCFC-133a, HCFC-254fb, HCFC-
30 1131, HCFO-1242zf, HCFO-1223xd, HCFC-233ab, HCFC-226ba, and HFC-227ca. The composition may contain anywhere from greater than zero weight percent to about 99 weight percent of HCFO-1233xf.

2023202867 09 May 2023

In addition, in accordance with the present invention, there is also provided a composition comprising HCFC-244bb and at least one additional compound selected from the group consisting of HCFO-1233zd, HCFO-1232xd, HCFO-1223xd, HCFC-253fb, HCFC-233ab, HFO-1234yf, 5 HFO-1234ze, ethylene, HFC-23, CFC-13, HFC-143a, HFC-152a, HFO-1243zf, HFC-236fa, HCO-1130, HCO-1130a, HFO-1336, HCFC-244db, HFC-245fa, HFC-245cb, HFC-245eb, HCFC-133a, HCFC-254fb, HCFC-1131, HCFO-1242zf, HCFO-1223xd, HCFC-233ab, HCFC-226ba, and HFC-227ca. The composition may contain anywhere from greater than 10 zero weight percent to about 99 weight percent of HCFC-244bb.

BRIEF DESCRIPTION OF THE DRAWINGS

FIG. 1 is a schematic drawing showing a reaction for producing HFO-1234yf from 243db.

15

DETAILED DESCRIPTION OF THE PREFERRED EMBODIMENTS

HFO-1234yf has been suggested for use as a refrigerant, heat transfer fluid, aerosol propellant, foam expansion agent, among other uses. It has also, advantageously, been found that HFO-1234yf has a low 20 global warming potential (GWP) as reported by V.C. Papadimitriou, et al. in Physical Chemistry Chemical Physics, 2007, volume 9, pages 1-13. Thus, HFO-1234yf is a good candidate for replacing the higher GWP saturated HFC refrigerants.

In one embodiment, the present disclosure provides a composition 25 comprising HFO-1234yf and at least one additional compound selected from the group consisting of HFO-1234ze, HFO-1243zf, HCFC-243db, HCFC-244db, HFC-245cb, HFC-245fa, HCFO-1233xf, HCFO-1233zd, HCFC-253fb, HCFC-234ab, HCFC-243fa, ethylene, HFC-23, CFC-13, HFC-143a, HFC-152a, HFC-236fa, HCO-1130, HCO-1130a, HFO-1336, 30 HCFC-133a, HCFC-254fb, HCFC-1131, HFO-1141, HCFO-1242zf, HCFO-1223xd, HCFC-233ab, HCFC-226ba, HFC-227ca.

2023202867 09 May 2023

In one embodiment, the total amount of additional compound(s) in the composition comprising HFO-1234yf ranges from greater than zero weight percent to less than 1 weight percent.

In some embodiments, the impurities present in the HCFC-243db, HCFO-1233xf, and HCFC-244bb will remain intact during the reaction to make HFO-1234yf, thus they are included in the additional compounds.

In another embodiment, the present disclosure provides a composition comprising HCFC-243db and at least one additional compound selected from the group consisting of ethylene, HFC-23, CFC-13, HFC-143a, HFC-152a, HFO-1234yf, HFO-1243zf, HFC-236fa, HCO-1130, HCO-1130a, HFO-1234ze, HFO-1336, HCFC-244bb, HCFC-244db, HFC-245fa, HFC-245cb, HCFC-133a, HCFC-254fb, HCFC-1131, HCFO-1233xf, HCFO-1233zd, HCFO-1242zf, HCFC-253fb, HCFO-1223xd, HCFC-233ab, HCFC-226ba, and HFC-227ca.

In one embodiment, the total amount of additional compound(s) in the composition comprising HCFC-243db ranges from greater than zero weight percent to about 99 weight percent. In another embodiment, the total amount of additional compounds ranges from about 1 weight percent to about 80 weight percent. In another embodiment, the total amount of additional compound(s) ranges from about 1 weight percent to about 50 weight percent. In another embodiment, the total amount of additional compound(s) ranges from about 1 weight percent to about 30 weight percent. In another embodiment, the total amount of additional compound(s) ranges from about 1 weight percent to about 10 weight percent.

In some embodiments, certain precursor compounds to HCFC-243db contain impurities that appear in the HCFC-243db. In other embodiments, the additional compounds are formed by reaction of these precursor impurities. In other embodiments, the reaction conditions under which the HCFC-243db is produced also produce by-products, by which is meant alternative reaction pathways may produce additional compounds depending upon the particular conditions under which the HCFC-243db is produced.

2023202867 09 May 2023

In another embodiment, the present disclosure provides a composition comprising HCFO-1233xf and at least one additional compound selected from the group consisting of HCFO-1233zd, HCFO-1232xd, HCFO-1223xd, HCFC-253fb, HCFC-233ab, HFO-1234yf, HFO-1234ze, ethylene, HFC-23, CFC-13, HFC-143a, HFC-152a, HFO-1243zf, HFC-236fa, HCO-1130, HCO-1130a, HFO-1336, HCFC-244bb, HCFC-244db, HFC-245fa, HFC-245cb, HCFC-133a, HCFC-254fb, HCFC-1131, HCFO-1242zf, HCFO-1223xd, HCFC-233ab, HCFC-226ba, HFC-227ca.

In one embodiment, the total amount of additional compound(s) in the composition comprising HCFO-1233xf ranges from greater than zero weight percent to about 99 weight percent. In another embodiment, the total amount of additional compounds ranges from about 1 weight percent to about 80 weight percent. In another embodiment, the total amount of additional compound(s) ranges from about 1 weight percent to about 50 weight percent. In another embodiment, the total amount of additional compound(s) ranges from about 1 weight percent to about 30 weight percent. In another embodiment, the total amount of additional compound(s) ranges from about 1 weight percent to about 10 weight percent.

In some embodiments, certain precursor compounds to HCFO-1233xf contain impurities that appear in the HCFO-1233xf. In other embodiments, the additional compounds are formed by reaction of these precursor impurities. In other embodiments, the reaction conditions under which the HCFO-1233xf is produced also produce by-products, by which is meant alternative reaction pathways may produce additional compounds depending upon the particular conditions under which the HCFO-1233xf is produced.

In another embodiment, the present disclosure provides a composition comprising HCFC-244bb and at least one additional compound selected from the group consisting of HCFO-1233zd, HCFO-1232xd, HCFO-1223xd, HCFC-253fb, HCFC-233ab, HFO-1234yf, HFO-1234ze, ethylene, HFC-23, CFC-13, HFC-143a, HFC-152a, HFO-1243zf, HFC-236fa, HCO-1130, HCO-1130a, HFO-1336, HCFC-244db, HFC-

2023202867 09 May 2023

245fa, HFC-245cb, HFC-245eb, HCFC-133a, HCFC-254fb, HCFC-1131, HCFO-1242zf, HCFO-1223xd, HCFC-233ab, HCFC-226ba, HFC-227ca.

In one embodiment, the total amount of additional compound(s) in the composition comprising HCFC-244bb ranges from greater than zero weight percent to about 99 weight percent. In another embodiment, the total amount of additional compounds ranges from about 1 weight percent to about 80 weight percent. In another embodiment, the total amount of additional compound(s) ranges from about 1 weight percent to about 50 weight percent. In another embodiment, the total amount of additional compound(s) ranges from about 1 weight percent to about 30 weight percent. In another embodiment, the total amount of additional compound(s) ranges from about 1 weight percent to about 10 weight percent.

In some embodiments, certain precursor compounds to HCFC-244bb contain impurities that appear in the HCFC-244bb. In other embodiments, the additional compounds are formed by reaction of these precursor impurities. In other embodiments, the reaction conditions under which the HCFC-244bb is produced also produce by-products that then appear in the HCFC-243db compositions, by which is meant alternative reaction pathways may produce additional compounds depending upon the particular conditions under which the HCFC-244bb is produced.

The compositions disclosed herein comprising HFO-1234yf are useful as low global warming potential (GWP) heat transfer compositions, aerosol propellant, foaming agents, blowing agents, solvents, cleaning agents, carrier fluids, displacement drying agents, buffing abrasion agents, polymerization media, expansion agents for polyolefins and polyurethane, gaseous dielectrics, extinguishing agents, and fire suppression agents in liquid or gaseous form. The disclosed compositions can act as a working fluid used to carry heat from a heat source to a heat sink. Such heat transfer compositions may also be useful as a refrigerant in a cycle wherein the fluid undergoes a phase change; that is, from a liquid to a gas and back or vice versa.

09 May 2023

2023202867

Examples of heat transfer systems include but are not limited to air conditioners, freezers, refrigerators, heat pumps, water chillers, flooded evaporator chillers, direct expansion chillers, walk-in coolers, heat pumps, mobile refrigerators, mobile air conditioning units and combinations thereof.

As used herein, mobile refrigeration apparatus, mobile air conditioning or mobile heating apparatus refers to any refrigeration, air conditioner, or heating apparatus incorporated into a transportation unit for the road, rail, sea or air. In addition, mobile refrigeration or air conditioner units, include those apparatus that are independent of any moving carrier and are known as "intermodal" systems. Such intermodal systems include "containers" (combined sea/land transport) as well as "swap bodies" (combined road/rail transport).

As used herein, stationary heat transfer systems are systems associated within or attached to buildings of any variety. These stationary applications may be stationary air conditioning and heat pumps (including but not limited to chillers, high temperature heat pumps, residential, commercial or industrial air conditioning systems, and including window, ductless, ducted, packaged terminal, chillers, and those exterior but connected to the building such as rooftop systems). In stationary refrigeration applications, the disclosed compositions may be useful in equipment including commercial, industrial or residential refrigerators and freezers, ice machines, self-contained coolers and freezers, flooded evaporator chillers, direct expansion chillers, walk-in and reach-in coolers and freezers, and combination systems. In some embodiments, the disclosed compositions may be used in supermarket refrigerator systems.

The compounds making up the disclosed compositions are defined in Table 1.

2023202867 09 May 2023

TABLE 1

Code	Structure	Chemical name
	$\text{CH}_2=\text{CH}_2$	Ethylene
CFC-13	CF_3Cl	chlorotrifluoromethane
HFC-23	CHF_3	trifluoromethane
HCFC-133a	$\text{CF}_3\text{CH}_2\text{Cl}$	2-chloro-1,1,1-trifluoroethane
HFO-134	CHF_2CHF_2	1,1,2,2-tetrafluoroethane
HFO-134a	$\text{CF}_3\text{CH}_2\text{F}$	1,1,1,2-tetrafluoroethane
HFC-143a	CF_3CH_3	1,1,1-trifluoroethane
HFC-152a	CHF_2CH_3	1,1-difluoroethane
HFC-227ca	$\text{CF}_3\text{CF}_2\text{CHF}_2$	1,1,1,2,2,3,3-heptafluoropropane
HCFC-233ab	$\text{CF}_3\text{CCl}_2\text{CH}_2\text{Cl}$	1,2,2-trichloro-3,3,3-trifluoropropane
HCFC-234ab	$\text{CF}_3\text{CCl}_2\text{CH}_2\text{F}$	2,2-dichloro-1,1,1,3-tetrafluoropropane
HFC-236fa	$\text{CF}_3\text{CH}_2\text{CF}_3$	1,1,1,3,3,3-hexafluoropropane
HCFC-243fa	$\text{CF}_3\text{CH}_2\text{CHCl}_2$	3,3-dichloro-1,1,1-trifluoropropane
HCFC-243db	$\text{CF}_3\text{CHClCH}_2\text{Cl}$	2,3-dichloro-1,1,1-trifluoropropane
HCFC-244bb	$\text{CF}_3\text{CFClCH}_3$	2-chloro-1,1,1,2-tetrafluoropropane
HCFC-244db	$\text{CF}_3\text{CHClCH}_2\text{F}$	2-chloro-1,1,1,3-tetrafluoropropane
HFC-245fa	$\text{CF}_3\text{CH}_2\text{CHF}_2$	1,1,1,3,3-pentafluoropropane
HFC-245cb	$\text{CF}_3\text{CF}_2\text{CH}_3$	1,1,1,2,2-pentafluoropropane
HFC-245eb	$\text{CF}_3\text{CHFCH}_2\text{F}$	1,1,1,2,3-pentafluoropropane
HCFC-253fb	$\text{CF}_3\text{CH}_2\text{CH}_2\text{Cl}$	3-chloro-1,1,1-trifluoropropane
HFC-254fb	$\text{CF}_3\text{CH}_2\text{CH}_2\text{F}$	1,1,1,3-tetrafluoropropane
HCO-1130	$\text{CHCl}=\text{CHCl}$	E- and/or Z-1,2-dichloroethene
HCO-1130a	$\text{CCl}_2=\text{CH}_2$	1,1-dichloroethene
HCFC-1131	$\text{CHF}=\text{CHCl}$	E- and/or Z-1-chloro-2-fluoroethene
HFO-1141	$\text{CHF}=\text{CH}_2$	fluoroethene
HCFO-1223xd	$\text{CF}_3\text{CCl}=\text{CHCl}$	1,2-difluoro-3,3,3-trifluoropropene
HCFO-1233zd	$\text{CF}_3\text{CH}=\text{CHCl}$	E- and/or Z-1-chloro-3,3,3-trifluoropropene
HCFO-1233xf	$\text{CF}_3\text{CCl}=\text{CH}_2$	2-chloro-1,1,1-trifluoropropene

2023202867 09 May 2023

HFO-1234yf	$\text{CF}_3\text{CF}=\text{CH}_2$	2,3,3,3-tetrafluoropropene
HFO-1234ze	$\text{CF}_3\text{CH}=\text{CHF}$	E- and/or Z-1,3,3,3-tetrafluoropropene
HCFO-1242zf	$\text{CClF}_2\text{CH}=\text{CH}_2$	3-chloro-3,3-difluoropropene
HFO-1243zf	$\text{CF}_3\text{CH}=\text{CH}_2$	1,1,1-trifluoropropene (TFP)
HFO-1336	$\text{C}_4\text{H}_2\text{F}_6$	E- and/or Z-hexafluorobutene

HCFC-243db, HCFO-1233xf, and HCFC-244bb are available from specialty chemical manufacturers, including SynQuest Laboratories, Inc. (Alachua, FL, U.S.A.) or may be made as described herein. For instance, 5 HCFC-243db, HCFO-1233xf, and HCFC-244bb may be prepared by non-catalytic chlorination of HFO-1243zf, as described in International Patent Application Publication No. WO2008/054782, published May 8, 2008. Also, HCFO-1233xf and HCFC-244bb may be prepared by catalytic fluorination of 243db as described in International Patent Application 10 Publication No. WO2008/054781, published May 8, 2008. The additional compounds present in each disclosed composition will depend upon the method of manufacture.

In some embodiments, certain precursor compounds to HCFC-243db, HCFO-1233xf, or HCFC-244bb contain impurities that then appear 15 as additional compounds in the described compositions. In other embodiments, these precursor compounds may themselves react during the 243db formation to form additional compounds that then appear in the HCFC-243db compositions. In other embodiments, the reaction conditions under which the HCFC-243db, HCFO-1233xf, or HCFC-244bb are 20 produced also produce by-products, by which is meant adventitious reaction pathways may occur simultaneously to produce compounds other than HCFC-243db, HCFO-1233xf or HCFC-244bb and the quantity and identity of these additional compounds will depend upon the particular conditions under which the HCFC-243db, HCFO-1233xf or HCFC-244bb 25 are produced.

In one embodiment, HFO-1234yf may be produced in a single step from HCFC-243db. In another embodiment, the reaction sequence may

09 May 2023

2023202867

be carried out in a step-wise manner. In another embodiment, HCFO-1233xf may be produced from HCFC-243db and then HCFO-1233xf may be converted directly to HFO-1234yf. In yet another embodiment, HCFC-244bb may be produced from HCFC-243db and then the HCFC-244bb
5 may be converted to HFO-1234yf.

Fluorochlorination of HFO-1243zf

In some embodiments, HFO-1243zf may be used to make HCFC-243db, HCFO-1233xf, HCFC-244db, and/or HFO-1234yf by
10 fluorochlorination. HFO-1243zf is commercially available from E.I. DuPont de Nemours and Company (Wilmington, DE, USA).

The fluorochlorination reaction may be carried out in the liquid or vapor phase. For liquid phase embodiments of the invention, the reaction of HFO-1243zf with HF and Cl₂ may be conducted in a liquid-phase
15 reactor operating in batch, semi-batch, semi-continuous, or continuous modes. In the batch mode, HFO-1243zf, Cl₂, and HF are combined in an autoclave or other suitable reaction vessel and heated to the desired temperature.

In one embodiment, this reaction is carried out in semi-batch mode
20 by feeding Cl₂ to a liquid-phase reactor containing HF and HFO-1243zf or by feeding HFO-1243zf and Cl₂ to a liquid-phase reactor containing HF, or by feeding Cl₂ to a mixture containing HF and reaction products formed by initially heating HFO-1243zf and HF. In another embodiment, HF and Cl₂ may be fed to a liquid-phase reactor containing a mixture of HFO-1243zf
25 and reaction products formed by reacting HF, Cl₂, and HFO-1243zf. In another embodiment of the liquid-phase process, HF, Cl₂, and HFO-1243zf may be fed concurrently in the desired stoichiometric ratio to the reactor containing a mixture of HF and reaction products formed by reacting HF, Cl₂, and HFO-1243zf.

30 Suitable temperatures for the reaction of HF and Cl₂ with HFO-1243zf in the liquid-phase reactor are, in one embodiment, from about 80°C to about 180°C, and in another embodiment, from about 100°C to

2023202867 09 May 2023

about 150°C. Higher temperatures typically result in greater conversion of the HFO-1243zf.

A suitable molar ratio of HF to total amount of HFO-1243zf fed to the liquid-phase reactor is, in one embodiment, at least stoichiometric and
5 in another embodiment, is from about 5:1 to about 100:1. Of note are embodiments wherein the molar ratio of HF to HFO-1243zf is from about 8:1 to about 50:1. A suitable molar ratio of Cl₂ to total amount of HFO-1243zf fed to the liquid-phase reactor is from about 1:1 to about 2:1.

The reactor pressure in the liquid-phase process is not critical and
10 in batch reactions is usually the autogenous pressure of the system at the reaction temperature. The pressure of the system increases as hydrogen chloride is formed by replacement of hydrogen substituents by chlorine, and by replacement of chlorine substituents by fluorine in the starting materials and intermediate reaction products. In a continuous process it is
15 possible to set the pressure of the reactor in such a way that the lower boiling products of the reaction, such as HCl, HFO-1234yf (CF₃CF=CH₂), *E/Z*-1234ze (*E/Z*-CF₃CH=CHF), and HFC-245cb (CF₃CF₂CH₃), are vented from the reactor, optionally through a packed column or condenser. In this manner, higher boiling intermediates remain in the reactor and the volatile
20 products are removed. Typical reactor pressures are from about 20 psig (239 kPa) to about 1,000 psig (6,994 kPa).

In some embodiments, in which the reaction is conducted using a liquid-phase process, catalysts which may be used include carbon, AlF₃, BF₃, FeCl_{3-a}F_a (where a = 0 to 3), FeX₃ supported on carbon, SbCl_{3-a}F_a,
25 AsF₃, MCl_{5-b}F_b (where b = 0 to 5 and M = Sb, Nb, Ta, or Mo), and M'Cl_{4-c}F_c (where c = 0 to 4, and M' = Sn, Ti, Zr, or Hf). In another embodiment, catalysts for the liquid phase process are MCl_{5-b}F_b (where b = 0 to 5 and M = Sb, Nb, or Ta).

In another embodiment, the reaction of HF and Cl₂ with HFO-
30 1243zf is carried out in the vapor phase. Typically a heated reactor is used. A number of reactor configurations are possible including horizontal or vertical orientation of the reactor as well as the sequence of reaction of

2023202867 09 May 2023

the HFO-1243zf with HF and Cl₂. In one embodiment of the invention, the HFO-1243zf may be initially vaporized and fed to the reactor as a gas.

In another embodiment of the invention, HFO-1243zf may be contacted with HF, optionally in the presence of Cl₂, in a pre-reactor prior to reaction in the vapor-phase reactor. In one embodiment, the pre-reactor may be empty. In another embodiment, the reactor is filled with a suitable packing such as nickel-copper alloys commercially available from Special Metals Corp. (New Hartford, New York) under the trademark Monel[®], (hereinafter "Monel[®]") nickel-based alloys commercially available from Haynes International (Kokomo, Indiana) under the trademark Hastelloy[®], (hereinafter "Hastelloy[®]") or other nickel alloy turnings or wool, or other material inert to HCl and HF which allows efficient mixing of HFO-1243zf and HF vapor.

Suitable temperatures for the pre-reactor in one embodiment are from about 80°C to about 250°C, in another embodiment, from about 100°C to about 200°C. Temperatures greater than about 100°C result in some conversion of the HFO-1243zf to compounds having a higher degree of fluorination. Higher temperatures result in greater conversion of the HFO-1243zf entering the reactor and a greater degree of fluorination in the converted compounds. Under these conditions, for example, a mixture of HF, Cl₂, and HFO-1243zf is converted to a mixture containing predominantly HCFC-243db and HCFC-244db (CF₃CHClCH₂F).

The degree of fluorination reflects the number of fluorine substituents that replace chlorine substituents in the HFO-1243zf and their chlorinated products. For example, HCFC-253fb represents a higher degree of fluorination than HCC-250fb and HFO-1243zf represents a higher degree of fluorination than HCO-1240zf.

The molar ratio of HF to the total amount of HFO-1243zf in the pre-reactor is in one embodiment, from about the stoichiometric ratio of HF to the total amount of HFO-1243zf to about 50:1. In another embodiment, the molar ratio of HF to the total amount of HFO-1243zf in the pre-reactor is from about twice the stoichiometric ratio of HF to the total amount of HFO-1243zf to about 30:1. In another embodiment, the molar ratio of HF

2023202867 09 May 2023

to the total amount of HFO-1243zf is present in the pre-reactor, and no additional amount of HF is added to the vapor-phase reaction zone.

In another embodiment, the HFO-1243zf may be contacted with Cl₂ in a pre-reactor, optionally in the presence of HF, prior to reaction in the vapor-phase reactor.

Suitable temperatures for the pre-reactor for this embodiment of the invention are from about 80°C to about 250°C, preferably from about 100°C to about 200°C. Under these conditions, at least a portion of HFO-1243zf is converted to HCFC-243db. Higher temperatures typically result in a higher degree of halogenation of the HFO-1243zf.

The degree of halogenation reflects the total number of halogen substituents (chlorine plus fluorine) in a halopropane and/or halopropene product. For example, HFO-1234yf has a higher degree of halogenation (i.e., 4) than does HFO-1243zf (i.e., 3).

The molar ratio of Cl₂ to the total amount of HFO-1243zf is, in one embodiment, from about 0.5:1 to about 2:1. In another embodiment, the molar ratio of Cl₂ to the total amount of the HFO-1243zf is from about 1.1:1 to about 1:1.

In one embodiment, the HFO-1243zf is vaporized, optionally in the presence of HF, and fed to a pre-reactor or to a vapor-phase reactor along with HF and Cl₂.

Suitable temperatures for the vapor-phase reaction are from about 120°C to about 500°C. Temperatures of from about 250°C to about 350°C favor the formation of HFO-1234yf and HFC-245cb. Temperatures of from about 350°C to about 450°C favor the formation of HFO-1234ze, HFC-245fa, and HCFO-1233zd. At temperatures of from about 250°C to about 450°C, some HCFO-1233xf is also produced. Higher temperatures result in greater conversion of HFO-1243zf and higher degrees of fluorination and halogenation in the converted compounds.

Suitable reactor pressures for the vapor-phase reactor may be from about 1 to about 30 atmospheres. A pressure of about 15 to about 25 atmospheres may be advantageously employed to facilitate separation of HCl from other reaction products, and the suitable reaction time may vary

2023202867 09 May 2023

from about 1 to about 120 seconds, preferably from about 5 to about 60 seconds.

The molar ratio of HF to the total amount of HFO-1243zf for the vapor-phase reaction is, in one embodiment, from about the stoichiometric ratio of HF to the total amount of HFO-1243zf to about 50:1 and, in
5 another embodiment, from about 10:1 to about 30:1.

In one embodiment, a catalyst is used in the reaction zone for the vapor-phase reaction of HF and Cl₂ with HFO-1243zf. Chlorofluorination catalysts which may be used in the vapor phase reaction include carbon;
10 graphite; alumina; fluorided alumina; aluminum fluoride; alumina supported on carbon; aluminum fluoride supported on carbon; fluorided alumina supported on carbon; magnesium fluoride supported on aluminum fluoride; metals (including elemental metals, metal oxides, metal halides, and/or other metal salts); metals supported on aluminum fluoride; metals
15 supported on fluorided alumina; metals supported on alumina; and metals supported on carbon; mixtures of metals.

Suitable metals for use as catalysts (optionally supported on alumina, aluminum fluoride, fluorided alumina, or carbon) include chromium, iron, cobalt, nickel, ruthenium, rhodium, palladium, osmium,
20 iridium, platinum, manganese, rhenium, scandium, yttrium, lanthanum, titanium, zirconium, and hafnium, copper, silver, gold, zinc, and/or metals having an atomic number of 58 through 71 (i.e., the lanthanide metals). In one embodiment, when used on a support, the total metal content of the catalyst will be from about 0.1 to about 20 percent by weight based on the
25 total weight of the catalyst; in another embodiment from about 0.1 to about 10 percent by weight based on the total weight of the catalyst.

Suitable chlorofluorination catalysts for the vapor-phase reactions include chromium-containing catalysts including chromium(III) oxide (Cr₂O₃); Cr₂O₃ with other metals such as magnesium halides or zinc
30 halides supported on Cr₂O₃; chromium(III) halides supported on carbon; mixtures of chromium and magnesium (including elemental metals, metal oxides, metal halides, and/or other metal salts) optionally supported on graphite; and mixtures of chromium and other metals (including elemental

2023202867 09 May 2023

metals, metal oxides, metal halides, and/or other metal salts) optionally supported on graphite, alumina, or aluminum halides such as aluminum fluoride.

Chromium-containing catalysts are well known in the art. They may
5 be prepared by either precipitation methods or impregnation methods as generally described by Satterfield on pages 87-112 in *Heterogeneous Catalysis in Industrial Practice*, 2nd edition (McGraw-Hill, New York, 1991).

Of note are chlorofluorination catalysts that comprise at least one chromium-containing component selected from the group consisting of
10 crystalline alpha-chromium oxide where from about 0.05 atom % to about 6 atom % of the chromium atoms in the alpha-chromium oxide lattice are replaced by trivalent cobalt atoms, and crystalline alpha-chromium oxide where from about 0.05 atom % to about 6 atom % of the chromium atoms in the alpha-chromium oxide lattice are replaced by trivalent cobalt atoms
15 which has been treated with a fluorinating agent. These catalysts, including their preparation, have been disclosed in U. S. Patent Application Publication US2005/0228202.

Optionally, the metal-containing catalysts described above can be pretreated with HF. This pretreatment can be accomplished, for example,
20 by placing the metal-containing catalyst in a suitable container, and thereafter, passing HF over the metal-containing catalyst. In one embodiment, such container can be the reactor used to perform the chlorofluorination reaction. In one embodiment, the pretreatment time is from about 15 to about 300 minutes, and the pretreatment temperature is
25 from about 200°C to about 450°C.

In one embodiment, the product mixture comprises HFC-245cb, HFC-245fa, HFO-1234yf, HFO-1234ze, HCFO-1233zd and HCFO-1233xf.

In one embodiment, halopropane by-products that may be formed in the chlorofluorination reactions having higher degrees of halogenation
30 and/or fluorination than pentafluoropropanes include CF₃CCl₂CF₃ (CFC-216aa), CF₃CClFCClF₂ (CFC-216ba), CF₃CClFCF₃ (CFC-217ba), CF₃CF₂CClF₂ (CFC-217ca), CF₃CHF₂CF₃ (HFC-227ea), CF₃CF₂CHF₂ (HFC-227ca), CF₃CClFCHF₂ (HCFC-226ba), CF₃CF₂CHClF (HCFC-

2023202867 09 May 2023

226ca), $\text{CF}_3\text{CHClCF}_3$ (HCFC-226da), $\text{CF}_3\text{CCl}_2\text{CHF}_2$ (HCFC-225aa),
 $\text{CF}_3\text{CClFCHClF}$ (HCFC-225ba), $\text{CF}_3\text{CF}_2\text{CHCl}_2$ (HCFC-225ca),
 $\text{CF}_3\text{CCl}_2\text{CClF}_2$ (CFC-215aa), $\text{CF}_3\text{CClFCCl}_2\text{F}$ (CFC-215bb), $\text{CF}_3\text{CCl}_2\text{CCl}_2\text{F}$
 (HCFC-214ab), $\text{CF}_3\text{CCl}_2\text{CHClF}$ (HCFC-224aa), and $\text{CF}_3\text{CClFCHCl}_2$
 5 (HCFC-224ba).

In one embodiment, halopropene by-products that may be formed
 in the chlorofluorination reactions having a higher degree of halogenation
 than tetrafluoropropenes include $\text{CF}_3\text{CCl}=\text{CHCl}$ (HCFO-1223xd).

In one embodiment, the product comprises HCFC-243db and at
 10 least one additional compound selected from the group consisting of
 ethylene, HFC-23, CFC-13, HFC-143a, HFC-152a, HFO-1234yf, HFO-
 1243zf, HFC-236fa, HCO-1130, HCO-1130a, HFO-1234ze, HFO-1336,
 HCFC-244db, HFC-245fa, HFC-245cb, HCFC-133a, HCFC-254fb, HCFC-
 1131, HCFO-1233xf, HCFO-1233zd, HCFO-1242zf, HCFC-253fb, HCFO-
 15 1223xd, HCFC-233ab, HCFC-226ba, and HFC-227ca.

In cases where the product mixture produced by the processes of
 this invention comprises (i) product compounds HFC-245cb, HFC-245fa,
 HFO-1234yf, HFO-1234ze, HCFO-1233zd and HCFO-1233xf, (ii) HF, HCl,
 and Cl_2 , (iii) higher boiling by-products such as $\text{CF}_3\text{CHClCH}_2\text{Cl}$ (HCFC-
 20 243db), $\text{CF}_3\text{CHClCH}_2\text{F}$ (HCFC-244bb) and (iv) chlorinated by-products
 such as $\text{C}_3\text{HCl}_3\text{F}_4$, $\text{C}_3\text{HCl}_2\text{F}_5$, C_3HClF_6 , $\text{C}_3\text{Cl}_3\text{F}_5$, and $\text{C}_3\text{Cl}_2\text{F}_6$, the
 separation processes, such as distillation, may be employed to recover the
 product compounds from such a product mixture.

25 Fluorination of HCFC-243db

In some embodiments, HCFC-243db may be used to make HCFC-
 HCFO-1233xf, HCFC-244db, and/or HFO-1234yf by fluorination. These
 reactions are shown in FIG. 1. The fluorination reaction may be carried
 out in the liquid or vapor phase. For liquid phase embodiments of the
 30 invention, the reaction of HCFC-243db with HF may be conducted in a
 liquid-phase reactor operating in batch, semi-batch, semi-continuous, or
 continuous modes. In the batch mode, starting HCFC-243db and HF are

2023202867 09 May 2023

combined in an autoclave or other suitable reaction vessel and heated to the desired temperature.

In one embodiment, this reaction is carried out in semi-batch mode by feeding HF to a liquid-phase reactor containing HCFC-243db or by
5 feeding HCFC-243db to a liquid-phase reactor containing HF, or by feeding HF to a mixture containing HF and reaction products formed by initially heating HCFC-243db and HF. In another embodiment, HF may be fed to a liquid-phase reactor containing a mixture of HCFC-243db and
10 reaction products formed by the reaction of HF, and HCFC-243db. In another embodiment of the liquid-phase process, HF, and HCFC-243db may be fed concurrently in the desired stoichiometric ratio to the reactor containing a mixture of HF and reaction products formed by reacting HF, and HCFC-243db.

Suitable temperatures for the reaction of HF with HCFC-243db in
15 the liquid-phase reactor are, in one embodiment, from about 80°C to about 180°C, in another embodiment, from about 100°C to about 150°C. Higher temperatures typically result in greater conversion of the HCFC-243db.

A suitable molar ratio of HF to HCFC-243db fed to the liquid-phase reactor is, in one embodiment, at least stoichiometric and, in another
20 embodiment, is from about 5:1 to about 100:1. Of note are embodiments wherein the molar ratio of HF to HCFC-243db is from about 8:1 to about 50:1.

The reactor pressure in the liquid-phase process is not critical and in batch reactions is usually the autogenous pressure of the system at the
25 reaction temperature. The pressure of the system increases as hydrogen chloride is formed by replacement of chlorine substituents by fluorine in the HCFC-243db and intermediate reaction products. In a continuous process it is possible to set the pressure of the reactor in such a way that the lower boiling products of the reaction, such as HCl, $\text{CF}_3\text{CF}=\text{CH}_2$, and
30 *E/Z*- $\text{CF}_3\text{CH}=\text{CHF}$, are vented from the reactor, optionally through a packed column or condenser. In this manner, higher boiling intermediates remain in the reactor and the volatile products are removed. Typical

2023202867 09 May 2023

reactor pressures are from about 20 psig (239 kPa) to about 1,000 psig (6,994 kPa).

In embodiments in which the reaction is conducted using a liquid-phase process, catalysts which may be used include carbon, AlF_3 , BF_3 ,
5 $\text{FeCl}_{3-a}\text{F}_a$ (where $a = 0$ to 3), FeX_3 supported on carbon, $\text{SbCl}_{3-a}\text{F}_a$, AsF_3 ,
 $\text{MCl}_{5-b}\text{F}_b$ (where $b = 0$ to 5 and $M = \text{Sb}, \text{Nb}, \text{Ta},$ or Mo), and $\text{M}'\text{Cl}_{4-c}\text{F}_c$
(where $c = 0$ to 4, and $M' = \text{Sn}, \text{Ti}, \text{Zr},$ or Hf). In one embodiment,
catalysts for the liquid phase process are $\text{MCl}_{5-b}\text{F}_b$ (where $b = 0$ to 5 and M
= $\text{Sb}, \text{Nb},$ or Ta).

10 In one embodiment, the reaction of HF with HCFC-243db is carried
out in the vapor phase. Typically a heated reactor is used. A number of
reactor configurations are possible including horizontal or vertical
orientation of the reactor as well as the sequence of reaction of the
starting materials with HF. In one embodiment, the HCFC-243db may be
15 initially vaporized and fed to the reactor as a gas.

In another embodiment of the invention, the HCFC-243db may be
contacted with HF in a pre-reactor prior to reaction in the vapor-phase
reactor. The pre-reactor may be empty, but is preferably filled with a
suitable packing such as nickel-copper alloys commercially available from
20 Special Metals Corp. (New Hartford, New York) under the trademark
Monel[®], nickel-based alloys such as Hastelloy[®], or other nickel alloy
turnings or wool, or other material inert to HCl and HF which allows
efficient mixing of HCFC-243db and HF vapor.

Suitable temperatures for the pre-reactor in one embodiment are
25 from about 80°C to about 250°C, in another embodiment, from about
100°C to about 200°C. Temperatures greater than about 100°C result in
some conversion of the HCFC-243db to compounds having a higher
degree of fluorination. Higher temperatures result in greater conversion of
the HCFC-243db entering the reactor and a greater degree of fluorination
30 in the converted compounds. Under these conditions, for example, a
mixture of HF and HCFC-243db is converted to a mixture containing
predominantly HF, HCl, HCFC-243db, HCFC-244db ($\text{CF}_3\text{CHClCH}_2\text{F}$), and
HCFO-1233xf.

2023202867 09 May 2023

The degree of fluorination reflects the number of fluorine substituents that replace chlorine substituents in the HCFC-243db and their fluorinated products. For example, HFO-1234yf represents a higher degree of fluorination than HCFO-1233xf.

5 The molar ratio of HF to the total amount of HCFC-243db in the pre-reactor is, in one embodiment, from about the stoichiometric ratio of HF to the total amount of HCFC-243db to about 50:1. In another embodiment, the molar ratio of HF to the total amount of HCFC-243db in the pre-reactor is from about twice the stoichiometric ratio of HF to the
10 total amount of HCFC-243db to about 30:1. In another embodiment, the molar ratio of HF to the amount of HCFC-243db is present in the pre-reactor, and no additional amount of HF is added to the vapor-phase reaction zone.

In one embodiment, the HCFC-243db and HF are vaporized and
15 fed to a pre-reactor or to a vapor-phase reactor.

Suitable temperatures for the vapor-phase reaction are from about 120°C to about 500°C. Temperatures in the range of from about 300°C to about 350°C favor the formation of HFO-1234yf and HFC-245cb and HCFO-1233xf. Temperatures in the range of from about 350°C to about
20 450°C favor the additional formation of HFO-1234ze, HFC-245fa, and HCFO-1233zd. Higher temperatures result in greater conversion of HCFC-243db and greater degrees of fluorination in the converted products. Reactor temperatures of from about 150°C to about 275°C favor the formation of HCFO-1233xf as the major product.

25 Suitable reactor pressures for the vapor-phase reactor may be from about 1 to about 30 atmospheres. A pressure of about 15 to about 25 atmospheres may be advantageously employed to facilitate separation of HCl from other reaction products, and the suitable reaction time may vary from about 1 to about 120 seconds, preferably from about 5 to about 60
30 seconds.

The molar ratio of HF to the amount of HCFC-243db for the vapor-phase reaction is, in one embodiment, from about the stoichiometric ratio

2023202867 09 May 2023

of HF to the amount of HCFC-243db to about 50:1 and, in another embodiment, from about 10:1 to about 30:1.

In some embodiments, a catalyst is used in the reaction zone for the vapor-phase reaction of HF with HCFC-243db. Fluorination catalysts which may be used in the vapor phase reaction include carbon; graphite; alumina; fluorided alumina; aluminum fluoride; alumina supported on carbon; aluminum fluoride supported on carbon; fluorided alumina supported on carbon; magnesium fluoride supported on aluminum fluoride; metals (including elemental metals, metal oxides, metal halides, and/or other metal salts); metals supported on aluminum fluoride; metals supported on fluorided alumina; metals supported on alumina; and metals supported on carbon; mixtures of metals.

Suitable metals for use as catalysts (optionally supported on alumina, aluminum fluoride, fluorided alumina, or carbon) include chromium, iron, cobalt, nickel, ruthenium, rhodium, palladium, osmium, iridium, platinum, manganese, rhenium, scandium, yttrium, lanthanum, titanium, zirconium, and hafnium, copper, silver, gold, zinc, and/or metals having an atomic number of 58 through 71 (i.e., the lanthanide metals). In some embodiments, when used on a support, the total metal content of the catalyst will be from about 0.1 to about 20 percent by weight based on the total weight of the catalyst; in another embodiment, from about 0.1 to about 10 percent by weight based on the total weight of the catalyst.

Typical fluorination catalysts for the vapor-phase reactions in this invention include chromium-containing catalysts including chromium(III) oxide (Cr_2O_3); Cr_2O_3 with other metals such as magnesium halides or zinc halides supported on Cr_2O_3 ; chromium(III) halides supported on carbon; mixtures of chromium and magnesium (including elemental metals, metal oxides, metal halides, and/or other metal salts) optionally supported on graphite; and mixtures of chromium and other metals (including elemental metals, metal oxides, metal halides, and/or other metal salts) optionally supported on graphite, alumina, or aluminum halides such as aluminum fluoride.

2023202867 09 May 2023

Chromium-containing catalysts are well known in the art. They may be prepared by either precipitation methods or impregnation methods as generally described by Satterfield on pages 87-112 in *Heterogeneous Catalysis in Industrial Practice*, 2nd edition (McGraw-Hill, New York, 1991).

5 Of note are fluorination catalysts that comprise at least one chromium-containing component selected from the group consisting of crystalline alpha-chromium oxide where from about 0.05 atom % to about 6 atom % of the chromium atoms in the alpha-chromium oxide lattice are replaced by trivalent cobalt atoms, and crystalline alpha-chromium oxide
10 where from about 0.05 atom % to about 6 atom % of the chromium atoms in the alpha-chromium oxide lattice are replaced by trivalent cobalt atoms which has been treated with a fluorinating agent. These catalysts, including their preparation, have been disclosed in U. S. Patent Application Publication US2005/0228202.

15 Optionally, the metal-containing catalysts described above can be pretreated with HF. This pretreatment can be accomplished, for example, by placing the metal-containing catalyst in a suitable container, and thereafter, passing HF over the metal-containing catalyst. In one embodiment of this invention, such container can be the reactor used to
20 perform the fluorination reaction in this invention. Typically, the pretreatment time is from about 15 to about 300 minutes, and the pretreatment temperature is from about 200°C to about 450°C.

In one embodiment of this invention, the product mixture comprises HFC-245cb, HFC-245fa, HFO-1234yf, HFO-1234ze, HCFO-1233zd and
25 HCFO-1233xf.

Fluorination of HCFO-1233xf

In some embodiments, HCFO-1233xf may be used to make HCFC-HCFC-244bb, and/or HFO-1234yf by fluorination. These reactions are
30 shown in FIG. 1.

In one embodiment, the reaction of HCFO-1233xf to HCFC-244bb may be carried out in the liquid phase. In another embodiment, the reaction may be carried out in the vapor phase.

2023202867 09 May 2023

In one embodiment, the reaction of HCFO-1233xf to HCFC-244bb may be carried out in batch mode. In another embodiment, the reaction may be carried out in a continuous mode.

In one embodiment, a liquid phase reaction of HCFO-1233xf to
5 HCFC-244bb may be carried out in the presence of a catalyst. In one
embodiment, the catalyst may be a Lewis acid catalyst. In one
embodiment, the catalyst may be a metal-halide catalyst. In another
embodiment, the catalyst may be at least one catalyst selected from the
group consisting of antimony halides, tin halides, thallium halides, iron
10 halides and combinations of two or more thereof. In another embodiment,
the catalysts may be at least one catalyst selected from antimony
pentachloride (SbCl_5), antimony trichloride (SbCl_3), antimony pentafluoride
(SbF_5), tin tetrachloride (SnCl_4), titanium tetrachloride (TiCl_4), iron
trichloride (FeCl_3), and combinations thereof. In some embodiments, the
15 reaction may be carried out with any known fluorination catalyst for liquid
phase reactions.

In one embodiment, the reaction of HCFO-1233xf to HCFC-244bb may be carried out in the absence of catalyst.

In one embodiment, a vapor phase reaction of HCFO-1233xf to
20 HCFC-244bb may be carried out in the presence of a catalyst. In one
embodiment, the reaction is carried out in the presence of a chromium-
based catalyst, an iron-based catalyst, or combinations thereof. In one
embodiment, the chromium based catalyst is a chromium oxide (e.g.
 Cr_2O_3). In one embodiment, the iron-based catalyst may be FeCl_3 on
25 carbon.

In one embodiment, the vapor phase reaction of HCFO-1233xf to
HCFC-244bb is carried out in the absence of catalyst.

Dehydrochlorination of HCFC-244bb

30 In some embodiments, dehydrochlorination of HCFC-244bb is used
to prepare HFO-1234yf.

In one embodiment, dehydrochlorination of HCFC-244bb to HFO-
1234yf is carried out in the vapor phase.

2023202867 09 May 2023

In one embodiment, vapor phase dehydrochlorination is carried out in the presence of catalyst. In one embodiment, the catalyst is selected from carbon and/or metal based catalysts. In one embodiment, the catalyst may be selected from an activated carbon, a nickel-based
5 catalyst, a palladium based catalyst, or any combination of these catalysts. In one embodiment, the catalyst may be selected from the group consisting of Ni-mesh, palladium on carbon, palladium on aluminum oxide, or combinations thereof.

In one embodiment, HFO-1234yf is prepared by thermal
10 dehydrochlorination of HCFC-244bb. In one embodiment, this reaction occurs in the absence of a catalyst. In one embodiment, HCFC-244bb is introduced into a reaction vessel which temperature is maintained at a temperature high enough to effect the thermal dehydrochlorination of HCFC-244bb. In one embodiment, the temperature is high enough to
15 effect the thermal dehydrochlorination of HCFC-244bb to a percent conversion of at least 50%. In another embodiment, the temperature is high enough to effect the thermal dehydrochlorination of HCFC-244bb to a percent conversion of at least 65%. In yet another embodiment, the temperature is high enough to effect the thermal dehydrochlorination of
20 HCFC-244bb to a percent conversion of at least 80%. In yet another embodiment, the temperature is high enough to effect the thermal dehydrochlorination of HCFC-244bb to a percent conversion of at least 70% for at least 12 hours of continuous operation.

In one embodiment, HCFC-244bb is introduced into a reaction
25 vessel into a reaction vessel which temperature is maintained at a temperature in the range of from about 500 °C to about 700 °C. In another embodiment, the temperature of the reaction vessel is maintained in the range from about 500 °C to about 650 °C. In yet another embodiment, the temperature of the reaction vessel is maintained at a temperature high
30 enough to effect the pyrolysis of HCFC-244bb to HFO-1234yf with a selectivity of 80% or greater. In yet another embodiment, the temperature of the reaction vessel is maintained at a temperature high enough to effect

2023202867 09 May 2023

the pyrolysis of HCFC-244bb to HFO-1234yf with a selectivity of 85% or greater.

In one embodiment, the reaction zone is a reaction vessel comprised of materials which are resistant to corrosion. In one
5 embodiment, these materials comprise alloys, such as nickel-based alloys such as Hastelloy[®], nickel-chromium alloys commercially available from Special Metals Corp. under the trademark Inconel[®] (hereinafter "Inconel[®]") or nickel-copper alloys commercially available from Special Metals Corp. (New Hartford, New York) under the trademark Monel[®], or vessels having
10 fluoropolymers linings.

In one embodiment, the HCFC-244bb is preheated in a vaporizer to a temperature of from about 30 °C to about 100 °C. In another embodiment, the HCFC-244bb is preheated in a vaporizer to a temperature of from about 30 °C to about 80 °C.

15 In some embodiments, an inert diluent gas is used as a carrier gas for HCFC-244bb. In one embodiment, the carrier gas is selected is nitrogen, argon, helium or carbon dioxide.

Without further elaboration, it is believed that one skilled in the art can, using the description herein, utilize the present invention to its fullest
20 extent. The following specific embodiments are, therefore, to be construed as merely illustrative, and do not constrain the remainder of the disclosure in any way whatsoever.

EXAMPLES

25

General Procedure for Product Analysis

The following general procedure is illustrative of the method used for analyzing the products of fluorination reactions. Part of the total reactor effluent was sampled on-line for organic product analysis using a
30 gas chromatograph equipped with a mass selective detector (GC/MS). The gas chromatography utilized a 20 ft. (6.1 m) long x 1/8 in. (0.32 cm) diameter tube containing perfluorinated polyether sold under the trademark Krytox[®] by E. I. du Pont de Nemours and Company

09 May 2023

2023202867

(hereinafter "DuPont") of Wilmington, Delaware on an inert carbon support. The helium flow was 30 mL/min (5.0×10^{-7} m³/sec). Gas chromatographic conditions were 60°C for an initial hold period of three minutes followed by temperature programming to 200°C at a rate of
 5 6°C/minute.

Preparation of 98%Chromium/2%Cobalt Catalyst

A solution of 784.30 grams Cr(NO₃)₃[9(H₂O)] (1.96 moles) and 11.64 grams Co(NO₃)₂[6(H₂O)] (0.040 mole) was prepared in 2000 mL of
 10 deionized water. The solution was treated dropwise with 950 mL of 7.4 M aqueous ammonia until the pH reached about 8.5. The slurry was stirred overnight at room temperature and then evaporated to dryness in air at 110-120°C. The dried catalyst was then calcined in air at 400°C for 24 hours prior to use.

15

LEGEND

243db is CF ₃ CHClCH ₂ Cl	244db is CF ₃ CHClCH ₂ F
245cb is CF ₃ CF ₂ CH ₃	245fa is CF ₃ CH ₂ CHF ₂
1234yf is CF ₃ CF=CH ₂	1233xf is CF ₃ CCl=CH ₂
20 1243zf is CH ₂ =CHCF ₃	233ab is CF ₃ CCl ₂ CH ₂ Cl
1233zd is <i>E</i> - and/or <i>Z</i> -CHCl=CHCF ₃	226ba is CF ₃ CClFCHF ₂
1234ze is <i>E</i> - and/or <i>Z</i> -CHF=CHCF ₃	227ca is CF ₃ CF ₂ CHF ₂
1223xd is <i>E</i> - and/or <i>Z</i> -CF ₃ CCl=CHCl	244bb is CF ₃ CFCICH ₃
1141 is CHF=CH ₂	

25

30

EXAMPLES 1-6

Chlorofluorination of HFO-1243zf

The 98% chromium/2% cobalt catalyst prepared above (21.4 grams, 15 mL, -12 to +20 mesh, (1.68 to 0.84 mm)) was placed in a 5/8"

2023202867 09 May 2023

(1.58 cm) diameter Inconel® (Special Metals Corp. (New Hartford, New York)) nickel alloy reactor tube heated in a fluidized sand bath. The catalyst was pre-fluorinated by treatment with HF as follows. The catalyst was heated from 45°C to 175°C in a flow of nitrogen (50 cc/min) over the course of about 1.5 hours. HF was then admitted to the reactor at a flow rate of 50 cc/min for 1.3 hours at a temperature of 175°C. The reactor nitrogen flow was decreased to 20 cc/min and the HF flow increased to 80 cc/min; this flow was maintained for 0.3 hour. The reactor temperature was then gradually increased to 400°C over 1 hour. After this period, the HF and nitrogen flow was stopped and the reactor brought to the desired operating temperature. A flow of HF vapor, HFO-1243zf, and Cl₂ then started through the reactor. Part of the reactor effluent was analyzed by on line GC/MS.

The results of the chlorofluorination of HFO-1243zf over the 98/2 Cr/Co catalyst at various operating temperatures and indicated molar ratios of HF, HFO-1243zf and Cl₂ are shown in Table 2; analytical data is given in units of GC area %. The nominal catalyst bed volume was 15 cc; the contact time (CT) was 15 seconds. Examples 1 and 2 were carried out in the absence of the catalyst.

TABLE 2 (Part A)
Chlorofluorination of HFO-1243zf

Ex. No.	HF/1243/Cl ₂ Ratio	T, °C	<u>1243zf</u>	<u>243db</u>	<u>244db</u>	<u>1234yf</u>	<u>245cb</u>	<u>1233xf</u>
1	10/1/4	140	3.0	54.2	9.8	5.7	0	1.4
2 ^a	10/1/1	140	31.3	46.2	11.8	2.8	0	1.5
3 ^b	10/1/1	300	5.9	0	0	5.9	22.2	30.7
4 ^c	10/1/4	325	0	0	0	0	0	0
5	10/1/1	350	9.1	0	0	11.3	11.3	25.2
6	10/1/1	375	12.8	0	0	11.6	6.3	20.6

2023202867 09 May 2023

TABLE 2 (Part B)
Chlorofluorination of HFO-1243zf

5	Ex. No.	HF/1243/Cl ₂ Ratio	T, °C	<u>1233zd</u>	<u>1234ze</u>	<u>245fa</u>	<u>1223xd</u>	<u>233ab</u>	<u>226ba</u>	<u>227ca</u>
	1	10/1/4	140	7.7	-	-	1.0	6.3	0	0
	2 ^a	10/1/1	140	1.4	-	-	0	1.3	0	0
10	3 ^b	10/1/1	300	4.1	2.1	1.3	20.2	0	0	0
	4 ^c	10/1/4	325	0	0	0	0	0	23.8	13.9
	5	10/1/1	350	12.4	4.7	1.9	18.1	0	0.2	0
	6	10/1/1	375	17.6	6.5	2.3	16.1	0	0.2	0

- 15 a. 243db and 244db confirmed by ¹H and ¹⁹F NMR.
 b. 245cb and 1233xf confirmed by ¹H and ¹⁹F NMR.
 c. Additional products were 215aa, 216aa, 216ba, 225aa, 225ba, 226ca, 226da.

EXAMPLES 7-11

Fluorination of HCFC-243db

20 The 98% chromium/2% cobalt catalyst prepared above (21.4 grams, 15 mL, -12 to +20 mesh, (1.68 to 0.84 mm)) was placed in a 5/8" (1.58 cm) diameter Inconel[®] nickel alloy reactor tube heated in a fluidized
 25 sand bath. The catalyst was pre-fluorinated by treatment with HF as follows. The catalyst was heated from 45°C to 175°C in a flow of nitrogen (50 cc/min) over the course of about 1.5 hours. HF was then admitted to the reactor at a flow rate of 50 cc/min for 1.3 hours at a temperature of
 30 175°C. The reactor nitrogen flow was decreased to 20 cc/min and the HF flow increased to 80 cc/min; this flow was maintained for 0.3 hour. The reactor temperature was then gradually increased to 400°C over 1 hour. After this period, the HF and nitrogen flow was stopped and the reactor brought to the desired operating temperature. A flow of HF vapor and

2023202867 09 May 2023

HCFC-243db (CF₃CHClCH₂Cl) was then started through the reactor. Part of the reactor effluent was analyzed by on line GC/MS.

The results of the fluorination of HFC-243db over the 98/2 Cr/Co catalyst at various operating temperatures and indicated molar ratios of HF and HCFC-243db are shown in Table 3; analytical data is given in units of GC area %. The nominal catalyst bed volume was 15 cc; the contact time (CT) was 15 seconds. Example 7 was carried out in the absence of the catalyst.

TABLE 3

Fluorination of HCFC-243db

Ex. No.	HF/243 Ratio	Temp. (°C)	<u>1243</u> <u>zf</u>	<u>243</u> <u>db</u>	<u>244</u> <u>db</u>	<u>1234</u> <u>yf</u>	<u>245</u> <u>cb</u>	<u>1233</u> <u>xf</u>	<u>1233</u> <u>zd</u>	<u>1234</u> <u>ze</u>	<u>245</u> <u>fa</u>
7	5/1	140	0.1	88.4	7.4	0	0	3.9	0	0	0
8	10/1	275	0	0.2	0.6	1.3	4.8	90.0	0	0.7	1.0
9	20/1	325	0	0	0	19.1	11.4	61.7	2.3	3.1	1.9
10	20/1	350	0	0	0	32.2	8.1	45.3	4.7	7.9	0.9
11	20/1	400	0	0	0	17.9	6.6	36.3	19.7	14.4	3.6

EXAMPLE 12

Reaction of HFC-243db with HF in the presence of TaF₅

A 210 mL Hastelloy[®] C tube was charged with 10.0 grams (0.0599 mole) of HCFC-243db and 25.4 grams (0.040 mole) of tantalum pentafluoride. The tube was then charged with 40.0 grams (2.0 moles) of hydrogen fluoride. The tube was warmed to 150°C and held at 149°C to 150°C for eight hours with shaking. The tube was then cooled to room temperature and treated with 100 mL of water. The contents of the tube were discharged and a small organic layer was collected and neutralized. The sample was 91.1% unconverted HCFC-243db; the GC-MS analysis of the converted products were as follows:

TABLE 4

<u>Component</u>	<u>GC Area %</u>
------------------	------------------

HFC-245cb	39.3
HFC-245fa	5.5
C ₃ H ₃ ClF ₄	9.2
C ₃ H ₃ ClF ₄	27.6
HCFC-253fb	2.9
HCFC-234ab	8.6
HCFC-243fa	6.9

EXAMPLE 13

Fluorination of HCFO-1233xf to HCFC-244bb

5 The contents of a small PTFE vial containing 20 grams of viscous SbF₅ were poured into a dry 400 mL Hastelloy[®] shaker tube. The tube was closed and was pressurized with nitrogen for leak testing. The shaker tube was then cooled to less than – 40 °C with dry ice, slowly vented, and then evacuated. 75 grams (3.75-moles) of anhydrous HF was condensed
10 into the shaker tube followed by 165 grams (1.26-moles) of HCFO-1233xf. The shaker tube was placed in a barricade and shaking was started.

 The shaker tube was agitated at ambient temperature (~20-23°C) and the pressure was 21 to 25 psig. After 2 hours, shaking was stopped and 150 mL of water was carefully pumped into the shaker tube. The tube
15 was left overnight and then cooled to 0 to 5°C in an ice bath before depressurization and transferring the contents to a plastic container. The container was kept on ice.

 The container contents were poured into a polypropylene separatory funnel containing some ice. The lower organic layer was light
20 amber in appearance. The organic layer was separated into a media bottle made of a glass sold under the trademark of Pyrex[®] by Corning (Lowell, MA) (hereinafter "Pyrex[®]") containing ~50-mL of 4 molar (pH 7) phosphate buffer and ice (~100-mL). The organic layer was again separated and poured into a dry Pyrex[®] media bottle containing a small

2023202867 09 May 2023

amount of anhydrous magnesium sulfate. Crude yield was 164.3 grams (about 120-mL, 86%).

GC/MS of the crude material showed that it was mostly HCFC-244bb. Other components included 0.13% 245cb, 0.09% 245eb, 0.16%
5 1233xf, and other byproducts totaling 12.2%.

EXAMPLE 14

Fluorination of HCFO-1233xf to HCFC-244bb

The contents of a small PTFE vial containing 20 grams of viscous
10 SbF₅ were poured into a dry 400-mL Hastelloy[®] shaker tube. The tube was closed and was pressurized with nitrogen for leak testing. The shaker tube was then cooled to less than – 40 °C with dry ice, slowly vented, and then evacuated. 53 grams (2.65 moles) of anhydrous HF was transferred into the shaker tube followed by 227 grams (1.74 moles) of HCFO-1233xf
15 was condensed into the chilled shaker tube. The shaker tube was placed in the barricade and shaking was started.

The shaker tube was agitated at ambient temperature (~18-21°C) and the pressure was 16 to 20 psig. After 2 hours, shaking was stopped and 100 mL of water was carefully pumped into the shaker tube. The tube
20 was left overnight and cooled to 0 to 5°C in an ice bath before venting and transferring the contents to a plastic container. The container was kept on ice.

The container contents were poured into a polypropylene separatory funnel containing some ice. The lower organic layer was light amber in
25 appearance. The organic layer was separated into a Pyrex[®] media bottle containing about 50 mL of 4 molar (pH 7) phosphate buffer and ice (~100-mL). The organic layer was again separated and poured into a dry Pyrex[®] media bottle containing a small amount of anhydrous magnesium sulfate. Crude yield was 238.8 grams (about 170-mL, 91%).

2023202867 09 May 2023

GC/MS of the crude material indicated that it was mostly HCFC-244bb. Other components included 0.11% HFC-245cb, 0.10% HFC-245eb, 0.26% HCFO-1233xf, and other byproducts totaling 9.7%.

5

EXAMPLE 15

Example 15 demonstrates the conversion of HCFC-244bb (2-chloro-1,1,1,2-tetrafluoropropane) to HFO-1234yf (2,3,3,3-tetrafluoropropane) in the absence of a catalyst.

An empty Inconel[®] tube (1/2 inch OD) with a heated zone of about 12 inches was heated to a temperature between 500°C and 626°C, and HFC-244bb was fed at 0.52 mL/hour through a vaporizer set at 40°C using a N₂ sweep of 2.4 sccm (4.0 x 10⁻⁸ m³). The reactor effluent was analyzed using an on-line GCMS, with the results being reported in mole percent.

15

TABLE 5

<u>Temp.,</u> ° C	<u>Mole Percent</u>								
	<u>23</u>	<u>1141</u>	<u>143a</u>	<u>245cb</u>	<u>1234yf</u>	<u>254eb</u>	<u>244bb</u>	<u>1233xf</u>	<u>Unks</u>
<u>500</u>	<u>0.2</u>	<u>0.1</u>	<u>0.0</u>	<u>0.4</u>	<u>14.2</u>	<u>1.0</u>	<u>82.6</u>	<u>1.2</u>	<u>0.0</u>
<u>550</u>	<u>1.9</u>	<u>0.9</u>	<u>0.1</u>	<u>0.0</u>	<u>57.0</u>	<u>1.7</u>	<u>35.4</u>	<u>1.2</u>	<u>1.6</u>
<u>574</u>	<u>2.7</u>	<u>1.1</u>	<u>0.1</u>	<u>0.0</u>	<u>77.0</u>	<u>1.9</u>	<u>13.0</u>	<u>1.4</u>	<u>2.8</u>
<u>603</u>	<u>6.8</u>	<u>2.4</u>	<u>0.2</u>	<u>0.0</u>	<u>85.0</u>	<u>1.4</u>	<u>1.3</u>	<u>0.7</u>	<u>2.2</u>
<u>626</u>	<u>6.9</u>	<u>2.0</u>	<u>0.2</u>	<u>0.0</u>	<u>82.5</u>	<u>0.7</u>	<u>0.2</u>	<u>1.4</u>	<u>5.9</u>

20

EXAMPLE 16

Example 16 demonstrates the conversion of HCFC-244bb (2-chloro-1,1,1,2-tetrafluoropropane) to HFO-1234yf (2,3,3,3-tetrafluoropropane) in the absence of a catalyst.

An empty Inconel[®] tube (1/2 inch OD) with a heated zone of about 12 inches was heated to 575°C, and HFC-244bb was fed at 0.35 mL/hour through a vaporizer set at 40°C using a N₂ sweep of 3.6 sccm (6.0 x 10⁻⁸

25

2023202867 09 May 2023

m³). The reactor was operated for a total of 19 hours continuously, and samples were taken periodically and analyzed to determine % conversion of HFC-244bb, and selectivity to HFO-1234yf. The reactor effluent was analyzed using an on-line GCMS, and the data in Table 6 below is an average of at least two on-line injections at a given condition; the percentages are mole percent.

TABLE 6

<u>Hours</u>	<u>23</u>	<u>1141</u>	<u>245cb</u>	<u>1234yf</u>	<u>254eb</u>	<u>244bb</u>	<u>1233xd</u>	<u>1223 (2 isomers)</u>	<u>Unk</u>
<u>3</u>	<u>1.9</u>	<u>0.8</u>	<u>0.1</u>	<u>68.8</u>	<u>3.5</u>	<u>17.9</u>	<u>5.1</u>	<u>0.5</u>	<u>1.3</u>
<u>4</u>	<u>1.4</u>	<u>0.7</u>	<u>0.0</u>	<u>61.5</u>	<u>4.2</u>	<u>22.7</u>	<u>7.4</u>	<u>1.1</u>	<u>1.0</u>
<u>8</u>	<u>0.0</u>	<u>0.3</u>	<u>0.0</u>	<u>61.1</u>	<u>2.6</u>	<u>15.0</u>	<u>14.1</u>	<u>3.9</u>	<u>2.8</u>
<u>12</u>	<u>0.0</u>	<u>0.5</u>	<u>0.0</u>	<u>60.1</u>	<u>2.0</u>	<u>13.7</u>	<u>16.4</u>	<u>6.0</u>	<u>1.3</u>
<u>15</u>	<u>0.9</u>	<u>0.3</u>	<u>0.0</u>	<u>66.9</u>	<u>1.7</u>	<u>14.5</u>	<u>12.0</u>	<u>2.7</u>	<u>1.0</u>
<u>19</u>	<u>0.0</u>	<u>0.7</u>	<u>0.0</u>	<u>67.4</u>	<u>0.0</u>	<u>7.0</u>	<u>16.6</u>	<u>8.2</u>	<u>0.0</u>

10

EXAMPLE 17

Example 17 demonstrates the dehydrochlorination of HCFC-244bb (2-chloro-1,1,1,2-tetrafluoropropane) in the presence of an activated carbon catalyst.

An Inconel[®] tube (1/2 inch OD) was filled with 4 cc (1.99 gm) of acid washed PCB Polynesian coconut shell based carbon from Calgon (6-10 mesh). HFC-244bb was fed at 1.04 mL/hour through a vaporizer set at 40°C using a N₂ sweep of 2.4 sccm (4.0 x 10⁻⁸ m³) giving a total contact time of about 32 seconds while controlling the reactor temperature at 400°C.

20

The data in Table 7 shows the reactor effluent composition in mole percent for this process run with an activated carbon catalyst to make HFC-1234yf via HCl elimination over the period of 7 hours of operation.

2023202867 09 May 2023

TABLE 7

<u>Hours</u>	<u>245cb</u>	<u>1234yf</u>	<u>245eb</u>	<u>1336</u>	<u>244bb</u>	<u>1233xf</u>	<u>Unk</u>
<u>1</u>	<u>0.0</u>	<u>52.2</u>	<u>0.2</u>	<u>0.0</u>	<u>22.4</u>	<u>10.3</u>	<u>14.9</u>
<u>2</u>	<u>0.0</u>	<u>44.5</u>	<u>0.2</u>	<u>0.1</u>	<u>24.6</u>	<u>13.4</u>	<u>17.3</u>
<u>3</u>	<u>0.0</u>	<u>38.0</u>	<u>0.2</u>	<u>0.2</u>	<u>31.9</u>	<u>14.8</u>	<u>15.0</u>
<u>4</u>	<u>0.0</u>	<u>25.9</u>	<u>0.2</u>	<u>0.1</u>	<u>41.8</u>	<u>15.7</u>	<u>16.3</u>
<u>5</u>	<u>0.0</u>	<u>15.5</u>	<u>0.3</u>	<u>0.1</u>	<u>49.4</u>	<u>17.9</u>	<u>16.7</u>
<u>6</u>	<u>0.5</u>	<u>7.1</u>	<u>0.3</u>	<u>0.1</u>	<u>53.8</u>	<u>18.0</u>	<u>20.2</u>
<u>7</u>	<u>0.6</u>	<u>2.9</u>	<u>0.3</u>	<u>0.1</u>	<u>54.2</u>	<u>17.3</u>	<u>24.5</u>

CLAIMS

What is claimed is:

1. A composition comprising HFO-1234yf and at least one
5 additional compound selected from the group consisting of HFO-1234ze,
HFO-1243zf, HCFC-243db, HCFC-244db, HFC-245cb, HFC-245fa,
HCFO-1233xf, HCFO-1233zd, HCFC-253fb, HCFC-234ab, HCFC-243fa,
ethylene, HFC-23, CFC-13, HFC-143a, HFC-152a, HFC-236fa, HCO-
1130, HCO-1130a, HFO-1336, HCFC-133a, HCFC-254fb, HCFC-1131,
10 HFO-1141, HCFO-1242zf, HCFO-1223xd, HCFC-233ab, HCFC-226ba,
and HFC-227ca.

2. The composition of claim 1 containing less than about 1 weight
percent of the at least one additional compound.

15

3. A composition comprising HCFC-243db and at least one
additional compound selected from the group consisting of ethylene, HFC-
23, CFC-13, HFC-143a, HFC-152a, HFO-1234yf, HFO-1243zf, HFC-
236fa, HCO-1130, HCO-1130a, HFO-1234ze, HFO-1336, HCFC-244bb,
20 HCFC-244db, HFC-245fa, HFC-245cb, HCFC-133a, HCFC-254fb, HCFC-
1131, HCFO-1233xf, HCFO-1233zd, HCFO-1242zf, HCFC-253fb, HCFO-
1223xd, HCFC-233ab, HCFC-226ba, and HFC-227ca.

4. A composition comprising HCFO-1233xf and at least one
25 additional compound selected from the group consisting of HCFO-1233zd,
HCFO-1232xd, HCFO-1223xd, HCFC-253fb, HCFC-233ab, HFO-1234yf,
HFO-1234ze, ethylene, HFC-23, CFC-13, HFC-143a, HFC-152a, HFO-
1243zf, HFC-236fa, HCO-1130, HCO-1130a, HFO-1336, HCFC-244bb,
HCFC-244db, HFC-245fa, HFC-245cb, HCFC-133a, HCFC-254fb, HCFC-
30 1131, HCFO-1242zf, HCFO-1223xd, HCFC-233ab, HCFC-226ba, and
HFC-227ca.

5. A composition comprising HCFC-244bb and at least one additional compound selected from the group consisting of HCFO-1233zd, HCFO-1232xd, HCFO-1223xd, HCFC-253fb, HCFC-233ab, HFO-1234yf, HFO-1234ze, ethylene, HFC-23, CFC-13, HFC-143a, HFC-152a, HFO-1243zf, HFC-236fa, HCO-1130, HCO-1130a, HFO-1336, HCFC-244db, HFC-245fa, HFC-245cb, HFC-245eb, HCFC-133a, HCFC-254fb, HCFC-1131, HCFO-1242zf, HCFO-1223xd, HCFC-233ab, HCFC-226ba, and HFC-227ca.

6. A composition comprising HCFC-243db and at least one additional compound selected from the group consisting of ethylene, HFC-23, CFC-13, HFC-143a, HFC-152a, HFO-1234yf, HFO-1243zf, HCO-1130, HCO-1130a, HFO-1234ze, HFO-1336, HCFC-244bb, HCFC-244db, HCFC-133a, HCFC-254fb, HCFC-1131, HCFO-1233xf, HCFO-1233zd, HCFO-1242zf, HCFC-253fb, HCFO-1223xd, HCFC-233ab, and HCFC-226ba.

2023202867 09 May 2023

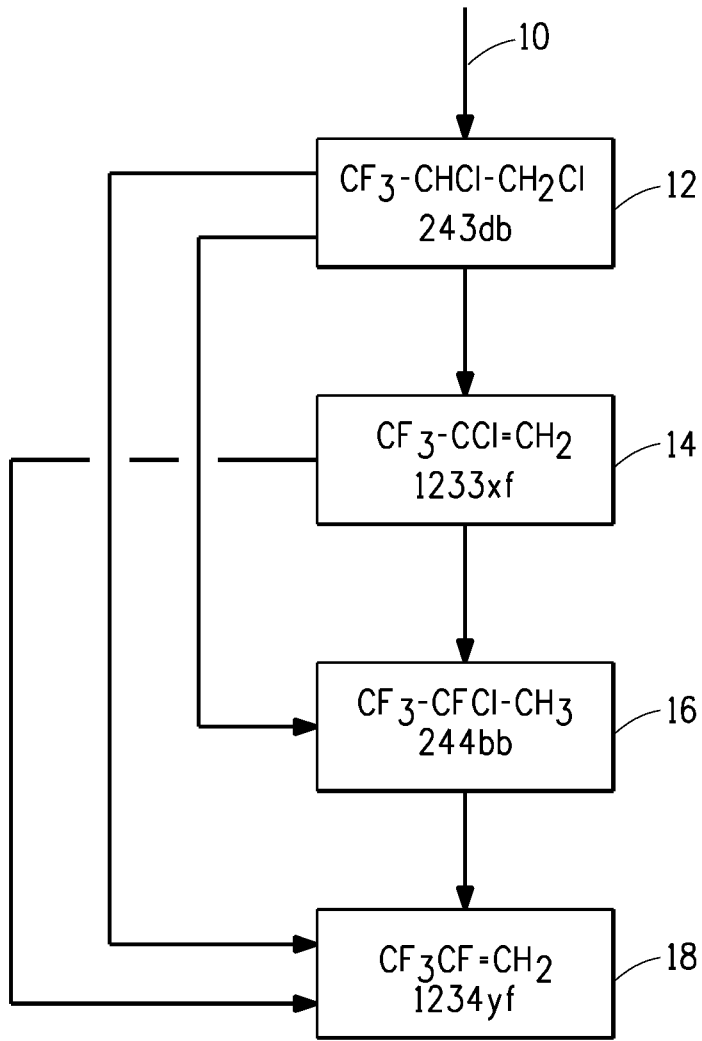

FIG. 1