



(19) **United States**

(12) **Patent Application Publication**

Sato et al.

(10) **Pub. No.: US 2007/0110595 A1**

(43) **Pub. Date: May 17, 2007**

(54) **FLUID CONVEYING MACHINE**

Publication Classification

(75) Inventors: **Tadashi Sato**, Fujisawa-shi (JP);
Satoshi Mori, Tokyo (JP); **Hiroyuki Kato**, Tokyo (JP)

(51) **Int. Cl.**
F04B 17/00 (2006.01)

(52) **U.S. Cl.** **417/351; 417/423.12**

Correspondence Address:
WESTERMAN, HATTORI, DANIELS & ADRIAN, LLP
1250 CONNECTICUT AVENUE, NW SUITE 700
WASHINGTON, DC 20036 (US)

(57) **ABSTRACT**

A fluid conveying machine has a rotational shaft (11), a double suction type pump (16), and magnetic levitation motors (12, 13) having a function as a radial magnetic bearing for supporting the rotational shaft (11) in a non-contact manner and as a motor for rotating the rotational shaft (11). The double suction type pump (16) has a double suction type impeller (21) attached to the rotational shaft (11), a pump casing (31) disposed so as to surround the impeller (21), and a pressure balance mechanism for positioning the rotational shaft (11) in an axial direction. The pump (16) is disposed substantially at a center of the rotational shaft (11), and the two magnetic levitation motors (12, 13) are disposed on both sides of the pump (16).

(73) Assignee: **EBARA CORPORATION**, TOKYO JAPAN (JP)

(21) Appl. No.: **10/581,701**

(22) PCT Filed: **Dec. 6, 2004**

(86) PCT No.: **PCT/JP04/18517**

§ 371(c)(1),
(2), (4) Date: **Jun. 6, 2006**

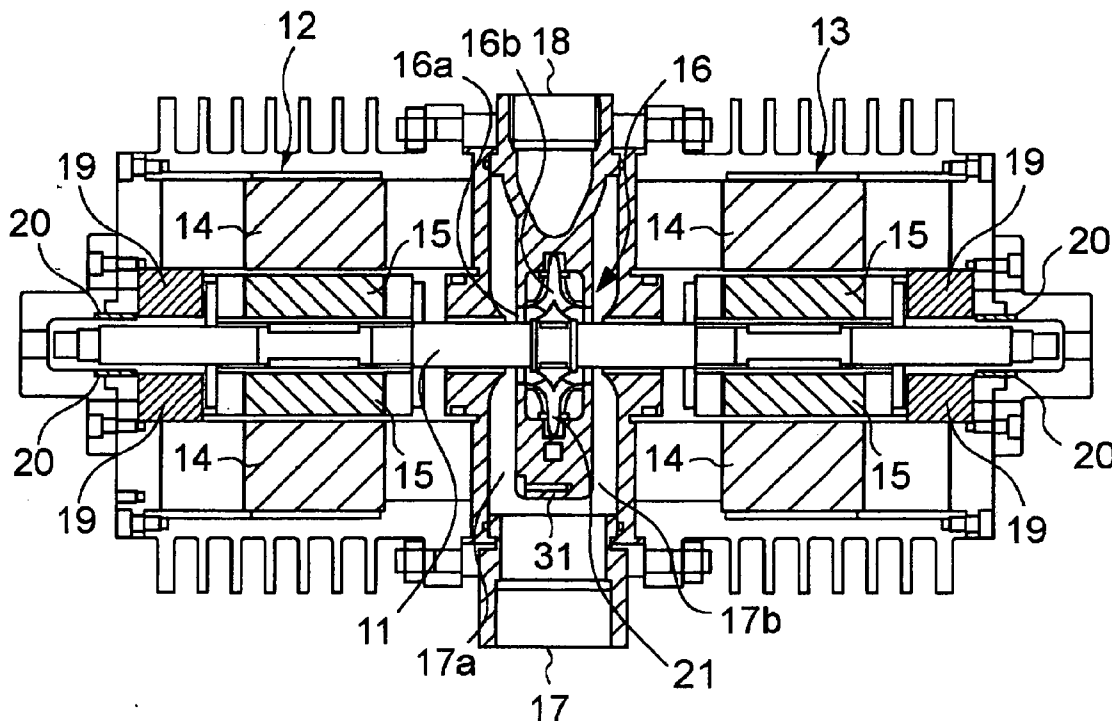

FIG. 1

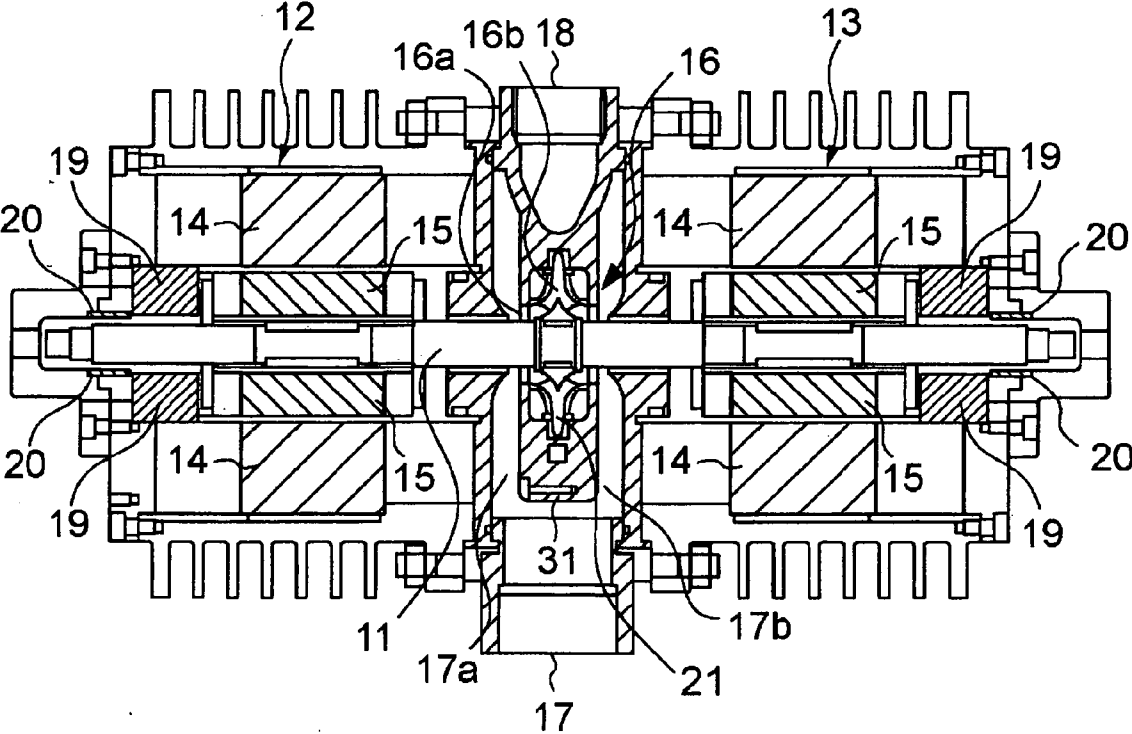

FIG. 2

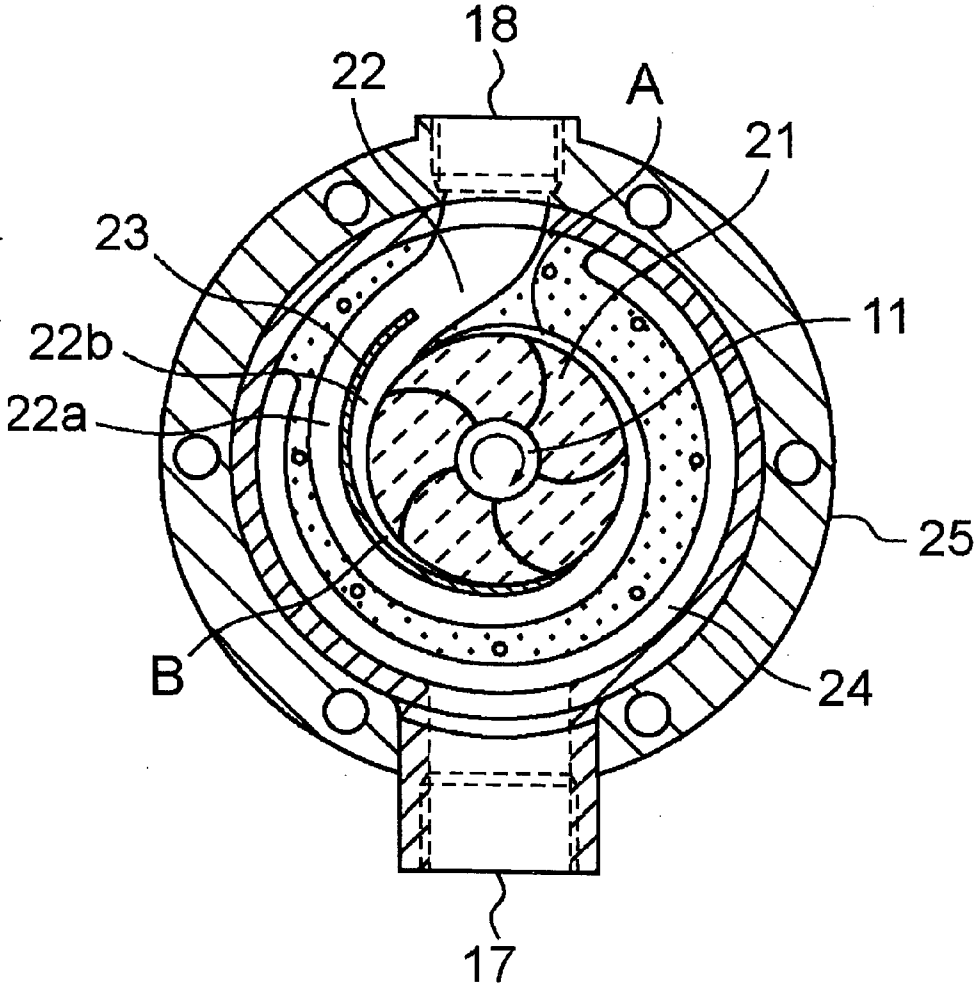

FIG. 3

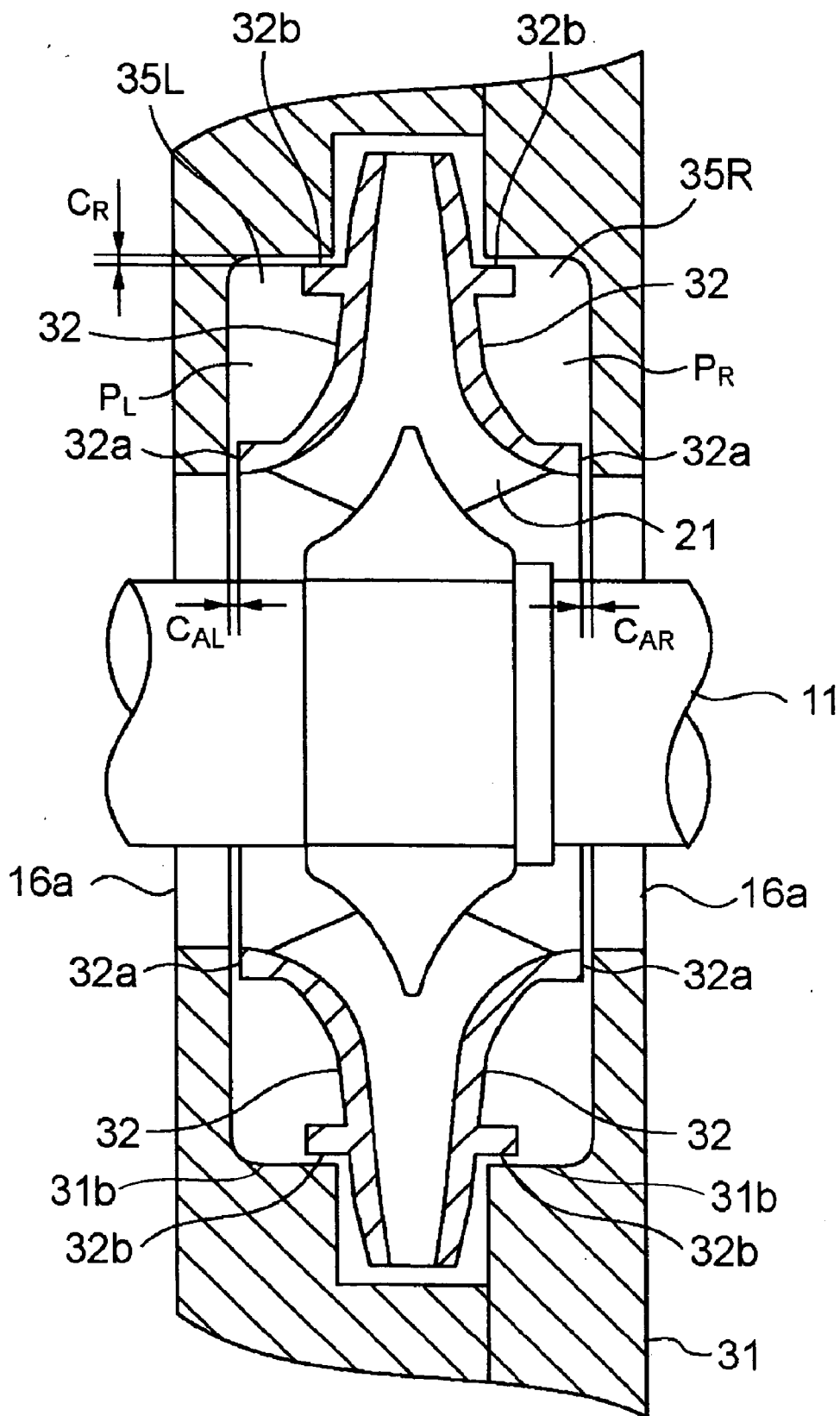
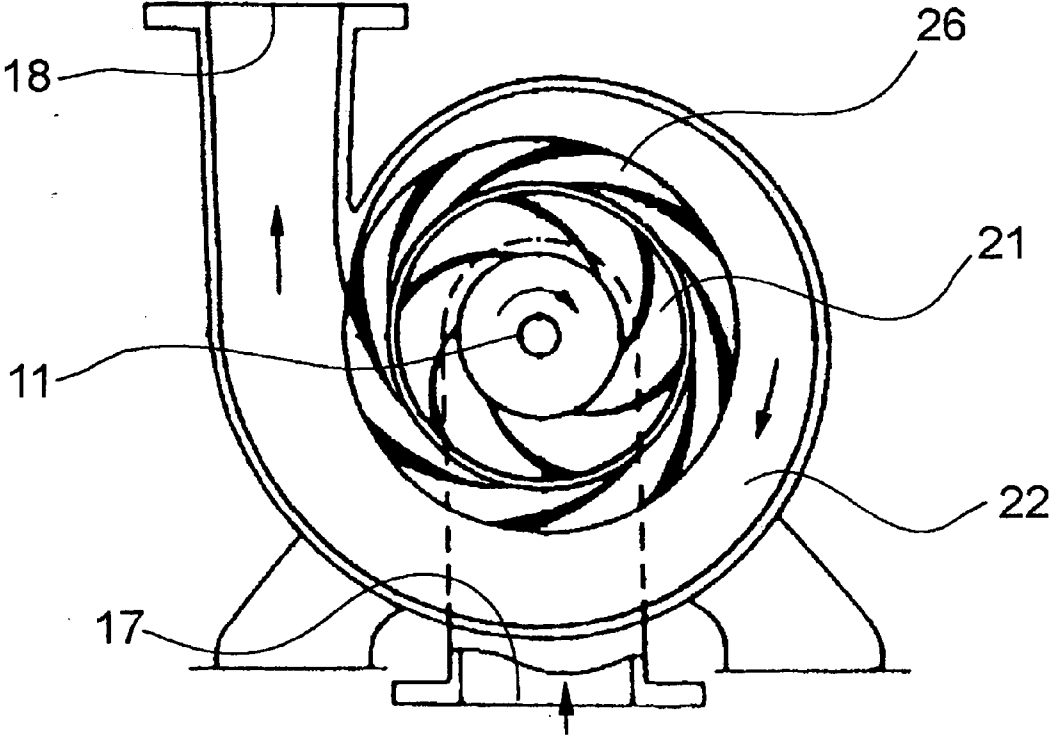

FIG. 4



FLUID CONVEYING MACHINE

TECHNICAL FIELD

[0001] The present invention relates to a fluid conveying machine, and more particularly to a fluid conveying machine such as a pump suitable for high-speed operation.

BACKGROUND ART

[0002] In a general motor, a magnetic flux distribution in a clearance between a stator and a rotor is of a rotational symmetry. In principle, no magnetic levitation force is produced in a radial direction. In contrast to the general motor, a magnetic levitation motor eccentrically locates a magnetic flux distribution in which two rotating magnetic fields are superposed between a rotor and a stator to produce a radial force. Specifically, there has been known a magnetic levitation motor which forms two rotating magnetic fields, the numbers of poles of which are different from each other by two, in the stator so as to provide a static magnetic force to the rotor in the radial direction and provide a rotational driving force to the rotor by superposition of the two rotating magnetic fields having different poles.

[0003] The magnetic levitation motor has both functions as a radial magnetic bearing and a motor. Thus, the magnetic levitation motor has functions to produce a rotational driving force on a rotor and to support the rotor in a non-contact manner in a radial direction by a magnetic levitation force. The function to support the rotational shaft in a non-contact manner in the radial direction can provide support for the rotational shaft in a non-contact manner even under an environment in which general bearings cannot be used, e.g., under an ultra-low temperature vacuum environment. Further, since the rotational shaft is supported in a non-contact manner, there are not friction nor wear. For example, the magnetic levitation motor is suitable for a conveying machine for a fluid which extremely needs to avoid mixing impurities, for example, ultrapure water.

[0004] Further, in a general centrifugal pump, a fluid force is produced in a suction direction (axial direction) at the time of operation to increase a load on an axial bearing. Accordingly, when an output of the pump is increased by operation such as increasing its rotational speed, an axial force applied to the rotational shaft is increased. In order to support the increased axial force, the axial magnetic bearing should be increased in size, thereby lengthening its axial dimension.

[0005] Further, when an impeller or an axial magnetic bearing is attached to an end of the rotational shaft, a bending frequency of the rotational shaft is lowered as compared to a case where an impeller or an axial magnetic bearing is attached to the center of the rotational shaft. Accordingly, the limit of rotational speeds, which is determined by a bending frequency, is problematically lowered. Furthermore, since the amount of eccentricity due to bending of the rotational shaft is increased, weight unbalance of the rotational shaft is increased to produce a large vibration at the time of high-speed rotation.

[0006] Further, the output of the centrifugal pump is increased as its rotational speed is increased. Accordingly, the same output can be obtained by a small-sized impeller when the pump is operated with high-speed rotation. This miniaturization reduces the weight of the rotating body,

increases the resonance frequencies of the axis, and facilitates magnetic levitation control. However, the high-speed operation of the pump induces cavitation to cause breakage of the impeller. Accordingly, increase of the rotational speed has a limitation.

DISCLOSURE OF INVENTION

[0007] The present invention has been made in view of the above drawbacks. It is, therefore, an object of the present invention to provide a fluid conveying machine having a small-sized compact structure capable of high-speed operation.

[0008] According to an aspect of the present invention, there is provided a fluid conveying machine having a small-sized compact structure capable of high-speed operation. The fluid conveying machine has a rotational shaft, a double suction type pump, and at least one magnetic levitation motor having a function as a radial magnetic bearing for supporting the rotational shaft in a non-contact manner and a function as a motor for rotating the rotational shaft. The double suction type pump has a double suction type impeller attached to the rotational shaft, a pump casing disposed so as to surround the impeller, and a pressure balance mechanism for positioning the rotational shaft in an axial direction.

[0009] According to the present invention, the rotational shaft is supported in a non-contact manner in a radial direction by the magnetic levitation motor and is positioned in a thrust direction by the pressure balance mechanism of the double suction type pump. Therefore, an axial bearing and an axial disk of the rotational shaft can be eliminated. Accordingly, it is possible to reduce the axial length of the rotational shaft. Further, since the rotational shaft is supported in a non-contact manner by the magnetic levitation motor, there is no friction or wear. Furthermore, the limit of rotational speeds, which is determined by a bending frequency, is increased by the shortened rotational shaft. Thus, a structure suitable for high-speed operation can be obtained. By providing the pump having the double suction type impeller, a rotational speed at which cavitation begins to be generated can be increased. Accordingly, even if the pump is operated at a high speed, cavitation is unlikely to be generated. Thus, stable high-speed operation of the pump can be achieved. Further, by increasing the rotational speed, a small-sized pump having a high output can be obtained.

[0010] It is desirable that the pump is disposed substantially at the center of the rotational shaft in the axial direction, and that two magnetic levitation motors are disposed on both sides of the pump. Since a frequency of an axis eigenvalue is increased, levitation stability region is enlarged to higher frequencies. This contributes to improvement of levitation stability.

[0011] The pump casing may have a double volute. In this case, radial components of a fluid force applied to the rotating body can be reduced so as to reduce energy loss. The pump casing may have a diffuser. In this case, radial components of a fluid force applied to the rotating body can be reduced so as to reduce energy loss.

[0012] Further, it is desirable that the pressure balance mechanism has a pair of variable clearances between each side of the impeller and the pump casing to balance pres-

tures on both sides of the impeller by sizes of the pair of variable clearances. The rotational shaft having the pump impeller can readily and reliably be positioned in the axial direction without using any axial disk or axial bearing.

[0013] As described above, according to the present invention, there can be provided a fluid conveying machine such as a pump which can reduce its axis length, minimize an influence of cavitation, operate at high speeds, and have a small-sized compact structure and a high output.

BRIEF DESCRIPTION OF DRAWINGS

[0014] FIG. 1 is a cross-sectional front view of a fluid conveying machine according to an embodiment of the present invention;

[0015] FIG. 2 is a cross-sectional view showing an example of a volute portion in the fluid conveying machine shown in FIG. 1;

[0016] FIG. 3 is a cross-sectional front view showing an example of an interior of a pump in the fluid conveying machine shown in FIG. 1; and

[0017] FIG. 4 is a cross-sectional view showing another example of a volute portion in the fluid conveying machine shown in FIG. 1.

BEST MODE FOR CARRYING OUT THE INVENTION

[0018] A fluid conveying machine according to embodiments of the present invention will be described below with reference to FIGS. 1 through 4. In FIGS. 1 through 4, parts or elements having the same function are denoted by the same reference numerals, and will not be described repetitively.

[0019] FIG. 1 shows a double suction type pump (fluid conveying machine) according to an embodiment of the present invention. The fluid conveying machine has a double suction type pump 16 disposed at a central portion thereof. A rotational shaft 11 of the pump 16 is rotated by magnetic levitation motors 12 and 13 disposed on both sides of the pump 16 and supported in a non-contact manner by the magnetic levitation motors 12 and 13, which serve as radial magnetic bearings. Displacement sensors 19 are disposed on both sides of the magnetic levitation motors 12 and 13. The magnetic levitation motors are controlled by a controller (not shown) based on measured displacements of the rotational shaft 11 so as to support the rotational shaft 11 in a levitated state at a predetermined position. Further, touchdown bearings 20 are disposed on both sides of the displacement sensors 19.

[0020] The double suction type pump 16 has an impeller 21 of bilateral symmetry and is thus a centrifugal pump for pressurizing a fluid, which has been drawn in an axial direction from both sides of the pump, in centrifugal directions (radial directions and tangential directions of the periphery). Specifically, a fluid drawn from a suction port 17 flows through passages 17a and 17b on both sides of a pump casing 31, then flows from opening portions 16a of the casing into a pump chamber 16b in an axial direction, is pressurized in centrifugal directions by the impeller 21, and is thus discharged through a double volute 22 shown in FIG. 2 from a discharge port 18.

[0021] FIG. 2 shows a cross-sectional arrangement of a main portion of the pump 16. The double suction type impeller 21 is secured to the rotational shaft 11 so as to pressurize a fluid in the centrifugal directions by rotation of the impeller 21 and convey the fluid through the volute 22 into the discharge port 18. The volute 22 has a partition wall 23 to form two volutes 22a and 22b, and thus a double volute is formed as a whole. The volutes 22a and 22b have inlet ports A and B, respectively, which are located at rotational symmetry positions which are rotated about the rotational shaft through 180°. Thus, since the pump is of a double volute type having two volute inlet ports A and B in the casing, it is possible to considerably reduce radial components of forces applied to the fluid pressurized by the impeller. Accordingly, it is possible to increase an efficiency of the pump and achieve quiet operation.

[0022] FIG. 3 shows an enlarged cross-sectional arrangement of the interior of the pump casing. As described above, the impeller 21 secured to the rotational shaft 11 has a double suction type structure of bilateral symmetry. The impeller 21 draws a fluid from the opening portions 16a on both sides of the casing 31 in an axial direction, pressurizes the fluid in centrifugal directions by rotating vanes (blades) of the impeller 21, and discharges the fluid through the double volute 22 (22a, 22b) from the discharge port 18 as described above.

[0023] Specifically, in the double suction type pump 16, a fluid is drawn from both sides of the pump 16 along the axial direction of the rotational shaft 11 and pressurized within shrouds 32 and 32 in the radial directions (and the tangential directions of the periphery) by the rotating impeller 21. Accordingly, an axial thrust (thrust force) in the axial direction is produced equally bilaterally, and no axial bearing is basically required. In this pump 16, there is provided a pressure balance mechanism for positioning the rotational shaft 11 in the axial direction by the double suction type pump 16.

[0024] The impeller 21 has the shrouds 32 and 32 of bilateral symmetry. Protrusions 32a and 32b of the shrouds 32 and 32 face inner surfaces of the casing 31 so as to produce clearances therebetween, respectively. Specifically, a pair of clearances C_{AL} and C_{AR} are formed between the protrusions 32a of the shrouds 32 and the inner surfaces of the casing 31 so as to form clearance resistances in passages through which the pressurized fluid returns to the suction side of the impeller. Similarly, a pair of clearances C_R and C_R are formed between the protrusions 32b of the shrouds 32 and the inner circumferential surfaces of the casing 31 so as to form clearance resistances in the passages through which the pressurized fluid returns to the suction side of the impeller.

[0025] Operation of this pressure balance mechanism is as follows. Assuming that the rotational shaft 11 moves to the left side in the drawing, the left clearance C_{AL} becomes smaller while the right clearance C_{AR} becomes larger. Accordingly, a pressure P_L in the chamber 35L is increased while a pressure P_R in the chamber 35R is reduced. As a result, the shrouds 32 and 32 and the rotational shaft 11 fixed to the shrouds are returned to substantially central portions of the chambers 35L and 35R by difference between the pressures P_L and P_R and positioned at those locations. Since the protrusions 32b of the shrouds 32 have a sufficient axial

length along the inner circumferential surfaces **31b** of the casing **31**, the clearances C_R can be maintained at constant values even if the rotational shaft **11** moves in the axial direction. Thus, constant clearance resistance can be maintained in return passages for the fluid pressurized by the pump to the chambers **35L** and **35R**.

[0026] Next, cavitation will be discussed. In a usual single suction type pump, a suction specific speed S , which is an indicator of cavitation generation limit is calculated by

$$S = \frac{n_s \cdot Q^{1/2}}{H_{NPSH}^{3/4}}$$

where a required net positive suction head is H_{NPSH} [m], a flow rate is Q [m^3/min], and a rotational speed is n_s [min^{-1}].

[0027] A double suction type pump has a symmetrical shape with respect to an axial direction, and is characterized in that suction ports are provided on both sides of the axis. A suction specific speed S is calculated by

$$S = \frac{n_d(Q/2)^{1/2}}{H_{NPSH}^{3/4}}$$

where a rotational speed of the double suction type pump is n_d . With regard to rotational speeds of cavitation generation limit in a single suction type pump and a double suction type pump having the same head and the same flow rate, the following relationship is derived from the above two equations.

$$\sqrt{2}n_d = n_s$$

Thus, in theory, a rotational speed at which cavitation begins to be generated in a double suction type pump is $\sqrt{2}$ times as high as a rotational speed at which cavitation begins to be generated in a single suction type pump. This difference practically provides the double suction type pump with higher rotation.

[0028] Next, support and drive of the rotational shaft by the magnetic levitation motors **12** and **13** will be described. The magnetic levitation motors **12** and **13** form two rotating magnetic fields, numbers of poles of which are different from each other by two, by windings (not shown) provided on the stators **14**, thereby rotating the rotors **15** secured to the rotational shaft **11** and magnetically supporting the rotors **15** in a levitated state. Specifically, for example, a rotating magnetic field having two poles and a rotating magnetic field having four poles are formed in the stators **14**. The two-pole rotating magnetic field serves as a motor to rotate the rotor **15**. The superposition of the two-pole rotating magnetic field and the four-pole rotating magnetic field forms a static magnetic flux distribution in the radial direction and serves as a radial magnetic bearing to support the rotational shaft **11** in a levitated state at a desired radial position by controlling the magnitude of the static magnetic flux distribution.

[0029] The control of the levitated position of the rotational shaft **11** can be performed in the following manner. The position of the rotational shaft is detected by the

displacement sensors **19**. The magnitude and phase of the four-pole rotating magnetic field (control magnetic field) supplied to the stators **14** are controlled by a controller (not shown) so that the rotational shaft **11** is supported at a predetermined position.

[0030] The use of the magnetic levitation motors instead of independent motor and magnetic bearing can not only reduce the number of parts but also shorten the length of the rotational shaft. Accordingly, it is possible to achieve improvement in high-speed rotation and cost. The non-contact support of the rotational shaft **11** is provided only in the radial direction by the magnetic levitation motors **12** and **13**. However, when a rotating body is to be supported completely in a non-contact manner, an additional axial magnetic bearing is required in the prior art.

[0031] An axial magnetic bearing is generally formed by a disk fixed to a shaft and electromagnets opposed to each other so as to interpose the disk therebetween in an axial direction. In a rotary machine having an axial magnetic bearing, the overall length of a rotational shaft becomes long. Accordingly, critical frequencies of the axis are lowered, thus making it difficult to achieve high-speed rotation, as described above. Further, addition of an axial bearing increases a surface area of a rotating body. The increase of the surface area increases a friction loss of a fluid surrounding the rotating body. As a result, an energy loss of the equipment is also increased.

[0032] However, when the double suction type pump **16** having the aforementioned pressure balance mechanism is combined with the magnetic levitation motors **12** and **13**, any axial magnetic bearing is not required at all. As a result, the rotational shaft can be shortened so as to increase resonance frequencies. Further, a fluid loss which would be produced on an axial magnetic bearing can be eliminated. Further, when the double suction type pump **16** is disposed at the center of the axis while the magnetic levitation motors **12** and **13** are disposed on both sides of the double suction type pump **16**, the apparatus can be made lightweight and compact, and weight unbalance of the rotational shaft can be eliminated. As a result, a frequency of an axis eigenvalue is increased, which contributes to levitation stability of the rotating body.

[0033] With this arrangement, when the motors disposed on both sides of the pump have the same dimension, the rotational shaft **11**, including a pumping section, can be made completely symmetrical in the axial direction. Thus, an axis eigenvalue can be maximized with the same axial length. Additionally, since the two magnetic levitation motors have the same dimension, axial support rigidities of the two magnetic levitation motors are completely equal to each other. Accordingly, no bearing unbalance is caused, and high-speed rotation is facilitated. Further, the same structure of the two motors provides mass production effects.

[0034] Further, when the pump casing is of the aforementioned double volute type, radial components of a fluid force applied to the rotating body can remarkably be reduced so that radial displacements of the rotating body magnetically supported in a levitated state can be made minute. Thus, a fluid conveying machine with less vibration can be provided. The effect to reduce radial vibration is not limited to the above double volute casing shape. A diffuser **26** properly arranged as shown in FIG. 4 can also remarkably reduce

radial components of a fluid force applied to the rotating body and thus achieve the similar effect.

[0035] As is apparent from the above discussion, combination of the double suction type pump and the magnetic levitation motors can eliminate an axial magnetic bearing and shorten the axial length of the pump. Accordingly, a lightweight and compact fluid conveying machine can be provided. Further, in cooperation with the shortened axial length and the unlikelihood of generation of cavitation in the double suction type pump, a higher-speed rotation can be performed as compared to a conventional pump. Accordingly, the present invention is effective in miniaturization and increase of output of a pumping portion.

[0036] Although certain examples of the present invention have been described in the above embodiments, it should be understood that various changes may be made therein without departing from the scope of the present invention.

INDUSTRIAL APPLICABILITY

[0037] The present invention can be utilized for a fluid machine such as a pump suitable for high-speed operation.

1. A fluid conveying machine comprising:

a rotational shaft;

a double suction type centrifugal pump, said double suction type centrifugal pump having a double suction type impeller attached to said rotational shaft for pressurizing a fluid in a centrifugal direction, a pump casing disposed so as to surround said impeller, and a pressure balance mechanism for positioning said rotational shaft in an axial direction; and

magnetic levitation motors, each of said magnetic levitation motors having a function as a radial magnetic bearing for supporting said rotational shaft in a non-contact manner and a function as a motor for rotating said rotational shaft,

wherein said pump is disposed substantially at a center of said rotational shaft in the axial direction,

wherein two magnetic levitation motors are disposed on both sides of said pump.

2. (canceled)

3. The fluid conveying machine as recited in claim 1, wherein said pump casing having a double volute.

4. The fluid conveying machine as recited in claim 1, wherein said pump casing having a diffuser.

5. The fluid conveying machine as recited in claim 1, wherein said pressure balance mechanism has a pair of variable clearances between each side of said impeller and said pump casing to balance pressures on both sides of said impeller by sizes of said pair of variable clearances.

6. The fluid conveying machine as recited in claim 1, wherein said magnetic levitation motor includes

a stator for forming two rotating magnetic fields, numbers of poles of which are different from each other by two, and

a rotor rotated and magnetically supported by said two rotating magnetic fields.

* * * * *