



INTERNATIONAL APPLICATION PUBLISHED UNDER THE PATENT COOPERATION TREATY (PCT)

(51) International Patent Classification ⁴ : B60G 21/04	A1	(11) International Publication Number: WO 90/11903 (43) International Publication Date: 18 October 1990 (18.10.90)
(21) International Application Number: PCT/AU90/00146 (22) International Filing Date: 12 April 1990 (12.04.90) (30) Priority data: PJ 3495 12 April 1989 (12.04.89) AU PJ 5246 13 July 1989 (13.07.89) AU PJ 5372 20 July 1989 (20.07.89) AU PJ 6653 29 September 1989 (29.09.89) AU PJ 7371 14 November 1989 (14.11.89) AU (71)(72) Applicant and Inventor: HEYRING, Christopher, Brian [AU/AU]; Fern Road, Eagle Bay, Cape Naturaliste, W.A. 6281 (AU). (74) Agent: WATERMARK PATENT & TRADE MARK AT- TORNEYS; Suite 18, 159 Adelaide Terrace, East Perth, W.A. 6004 (AU).		(81) Designated States: AT (European patent), AU, BE (Euro- + pean patent), BR, CA, CH (European patent), DE (Eu- ropean patent), DK (European patent), ES (European patent), FR (European patent), GB (European patent), IT (European patent), JP, LU (European patent), NL (European patent), SE (European patent), SU, US. Published <i>With international search report.</i> <i>Before the expiration of the time limit for amending the</i> <i>claims and to be republished in the event of the receipt of</i> <i>amendments.</i>

(54) Title: VEHICLE SUSPENSION**(57) Abstract**

A vehicle for travelling over rough land or water having a body (60) to support a load, and front and rear wheel or float assemblies (61, 62) pivotally connected to the respective ends of the body to pivot about respective coaxial or parallel axes. A stabilising structure (67, 68, 69) interconnecting the respective assemblies (61, 62) so that pivotal movement of one assembly induces an opposite and conveniently equal angular movement of the other assembly. The stabilising structure including a torsion member connected to the body to control the position thereof.

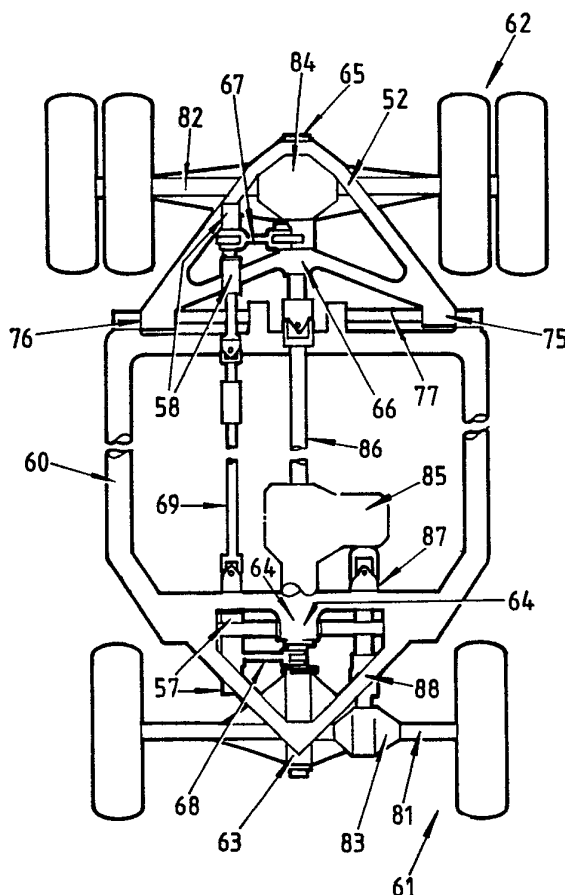

DESIGNATIONS OF "DE"

Until further notice, any designation of "DE" in any international application whose international filing date is prior to October 3, 1990, shall have effect in the territory of the Federal Republic of Germany with the exception of the territory of the former German Democratic Republic.

FOR THE PURPOSES OF INFORMATION ONLY

Codes used to identify States party to the PCT on the front pages of pamphlets publishing international applications under the PCT.

AT	Austria	ES	Spain	MG	Madagascar
AU	Australia	FI	Finland	ML	Mali
BB	Barbados	FR	France	MR	Mauritania
BE	Belgium	GA	Gabon	MW	Malawi
BF	Burkina Faso	GB	United Kingdom	NL	Netherlands
BG	Bulgaria	HU	Hungary	NO	Norway
BJ	Benin	IT	Italy	RO	Romania
BR	Brazil	JP	Japan	SD	Sudan
CA	Canada	KP	Democratic People's Republic of Korea	SE	Sweden
CF	Central African Republic	KR	Republic of Korea	SN	Senegal
CG	Congo	LI	Liechtenstein	SU	Soviet Union
CH	Switzerland	LK	Sri Lanka	TD	Chad
CM	Cameroon	LJ	Luxembourg	TG	Togo
DE	Germany, Federal Republic of	MC	Monaco	US	United States of America
DK	Denmark				

VEHICLE SUSPENSION

This invention relates to a vehicle which in use traverses an uneven surface, and to a suspension system therefor which will reduce the movement imparted to a body of the vehicle when traversing such uneven surfaces.

The invention is particularly applicable to vehicles which traverse land surfaces, however, it is equally applicable to vessels which travel over water and also to anchored floating vessels which may not actually travel, but where the water movement past the relatively stationary vessel induces movement of the vessel.

Conventional motor vehicles have sophisticated suspension systems to reduce the movement transmitted to the vehicle body by movement of the wheels as the wheels traverse irregularities in the road or ground surface. Such suspension systems are appropriate where the load carried by the vehicle is within specific known limits of variation and where such variation is relatively small. However, in large and heavy vehicles commonly used in off-road situations, such as agricultural vehicles and machinery, earthmoving machinery, mobile cranes and the like, the variation in loads and extent of vertical movement of the wheels are normally so large as to not be within the capacity of conventional suspension systems.

In many agricultural tractors and other off-road type earth moving and working vehicles, there are provided respective front and rear axles, each carrying a pair of wheels. One of the axles is rigidly attached to the body of the vehicle, whilst the other is pivotally connected at its central point to the body of the vehicle without any suspension media between that axle and the vehicle body. Thus in effect, the vehicle is supported on three points, namely the two wheels on the rigid axle and the one central pivot connection to the other axle. This triangular form of support for the vehicle body frequently leads to a deceptive situation where the operator considers the stability of the vehicle relates to the relatively widely spaced four points

-2-

of contact between the vehicle wheels and the ground, whereas the stability is really defined by the relatively narrow triangular formation of the three points of support. This deceptive situation frequently leads to hazardous operation and potential accidents.

5 A wide variety of suspension constructions for vehicles has been disclosed in patent literature, and the disclosures in U.S. patent Nos. 1,439,802 and 3,917,306, are considered to be closest relating prior art to the present invention. Each of these specifications disclose a vehicle having respective front and rear axle assemblies interconnected by a pair of transversely spaced rigid beams each pivoted centrally to the vehicle chassis or body. The beams pass along the respective opposite longitudinal sides of the vehicle chassis each constituting what might be called a rocker beam. At each end of the vehicle the rocker beams are connected to respective transversely disposed spring assemblies which in turn are pivotally connected to the vehicle chassis to pivot relative thereto about a central longitudinal axis. As the longitudinal members act in the manner of a centrally pivoted beam they are subjected to substantial bending loads and therefore must be of a rigid and hence relatively heavy construction. The use of such heavy beams in modern vehicles is generally unacceptable for a number of reasons, including the weight of the beams and the resultant additional strength required in the general vehicle construction, and the resultant increase in fuel consumption and/or relatively poor overall vehicle performance.

10
15
20
25
30
35 It is therefore the principal object of the present invention to provide in a vehicle support system for traversing uneven surfaces or terrain which provides an improved stability to the vehicle by maintaining a weight distribution between the wheels or other supports similar to that when traversing a substantially even surface, and limit the lateral tilting of the body of the vehicle, and is effective in operation, relatively economic to construct, and relatively light in weight.

-3-

With this object in view there is provided a land vehicle comprising a load carrying body, two axle and wheel assemblies, adapted to support the body to allow traversing thereof over land, said axle and wheel assemblies being spaced in opposite directions from the centre of gravity of the body and load carried thereby, each assembly being pivotally connected to the body for limited angular movement about a common or respective parallel axes extending generally in the longitudinal direction of the vehicle, and stabilising means interconnecting said two axle and wheel assemblies and including a torsion member rotatably supported by the body for movement about an axis not co-axial with both the axle and wheel assembly pivot axes, said torque member being operatively coupled to the respective axle and wheel assemblies so that angular movement of either one of said assemblies relative to the body effects an opposite, preferably equal, angular movement of the other of said assembly relative to the body.

Preferably the stabilising means comprises a mechanical mechanism supported by the body and arranged to provide a constant coupling between the two axle and wheel assemblies to drive in either direction to achieve the required reversal in direction of angular movement between said assemblies. A gear train or a linkage system can be included to provide an interconnection to obtain the required reverse of the pivotal movement of the assemblies relative to the body. Conveniently each of the axle and wheel assemblies is directly coupled to respective directly meshing gears journalled in the body, to thereby obtain the required reversal in the direction of angular movement of the respective assemblies relative to the vehicle body.

The transmission of movement between the two support means by a torsion member journalled in the body about an axis offset laterally from or inclined to the axes of the axle and wheel assemblies resulting in the stability of the vehicle being improved, in that the body of the vehicle is only subject to an angular movement equal to one

-4-

half of the arithmetic sum of the angular movements of the two axle and wheel assemblies relative to the body. Thus if each of the assemblies are subject to equal and opposite angular movements relative to the body, then there is no angular movement transmitted to the body. However, in the event that one of the assemblies is subject to angular movement relative to the body and the other is prevented from angular movement, then the body itself will move relative to the non-movable axle and wheel assembly by an angle equal to half of the angle of movement of the one assembly relative to the other assembly. The stabilising means may be arranged to one axle and wheel assembly preferably the rear one, has a greater angular movement relative to the body than the other, such as a 3:2 ratio.

In a conventional land vehicle, each of the axle and wheel assemblies will conveniently comprise an axle rotatably supporting a wheel at each end. Each axle is pivotally connected to the vehicle body for relative angular movement about an axis normal to the axis of the wheels. Conveniently the pivotal connection comprises a respective rigid shaft journalled in bearings on the body and rigidly connected at one end to one axle and carrying a bevel gear at the opposite end. The two rigid shafts and their associated bevel gears are arranged co-axially, with the bevel gears on each of the shafts meshing with a further intermediate bevel gear rotatably supported on the vehicle body with an axis normal to the common axis of the two shafts.

In an alternative construction, the or each axle and wheel assembly comprises a transverse rigid member pivotally connected to the vehicle body, and respective arms pivotally connected to the rigid member on opposite sides of the pivot connection to the body and about axes parallel to the pivot axis of the rigid member. Each arm supporting a respective wheel for rotation about an axis transverse to the pivot axis of the rigid member to the body, and resilient suspension means interconnected between the arms

-5-

and/or the arms and the rigid member. Conveniently each axle and wheel assembly includes shock absorbing means to damp the pivotal movement between the respective wheels and the rigid member. The suspension means may include individual springs operably interposed between the
5 respective arms and the rigid member, such as individual coil springs or torsion bars. Alternatively, a single leaf spring may be provided centrally coupled to the rigid member with the respective ends coupled to the two arms.

10 Conveniently a power unit is mounted upon the body of the vehicle with the power transmission drive shafts to either or both of the axle and wheel assemblies pivotally mounted on the body. Conveniently, a transmission housing is pivotally mounted in bearings on the body and the housing
15 is rigidly attached to the axle and wheel assembly to provide a pivotal support between each assembly and the body. A drive shaft is provided to couple the power plant to the axle and wheel assembly.

In the case of a four wheel drive vehicle the power
20 unit may conveniently transmit its power through the differential transmission units to each of the four wheels on the vehicle. Each assembly includes a differential transmitting power to the wheel axles from the transmission shaft, which in turn can be driven by a third differential
25 mounted on the rigid frame directly connected to the power unit.

Also where suspension means are provided between the wheels and the member supporting them and pivotally coupled to the body, the suspension can be of a pneumatic or
30 hydro-pneumatic type. Also the stabilising means can have a degree of resilience so that there is some loss of rotatory movement between the respective axle assemblies. Thus the torsion member can be designed to twist to a degree in operation to provide a resilient character. The invention
35 will be more readily understood from the following description of some practical arrangements of the invention as illustrated in the accompanying drawings.

-6-

In the drawings:

Figure 1 is a diagrammatic plan view of one arrangement of a land vehicle incorporating the present invention;

5 Figure 2 is a diagrammatic plan view of a modification of the arrangement shown in Figure 1;

Figure 3 is a front view of the arrangement as shown in Figure 2 with one wheel located higher than the other.

10 Figure 4 is a plan view of an alternative application of the invention to a land vehicle;

Figure 5 is a front view of an alternative suspension system to that shown in Figures 2 and 3.

Referring now to Figure 1, the vehicle frame or chassis 60 is of a rigid construction and may take a variety of forms, that shown in the drawing being merely one of such forms. The frame 60 is supported at either end by a front and rear wheel assembly 61 and 62 respectively.

20 The front wheel assembly 61 is pivotally supported in the frame 60 by bearing units 63 and 64 and the rear axle assembly 62 is pivotally supported in bearing units 65 and 66 in the sub-frame 59 which is pivotally supported in the frame by bearing units 75 and 76. The front and rear axle assemblies 61 and 62 are coupled by arms 67 and 68 to the universal jointed shaft 69 rotatably supported in the frame 25 60 and sub-frame 59 at bearing 57 and 58 respectively. The arms 67 and 68 are connected to the shaft 69, one above and one below the axis of the shaft 69, resulting in rotational movement of one of the axle assemblies relative to the frame 30 60 inducing an equal and opposite rotational movement of the other wheel assembly relative to the frame 60.

35 The sub-frame 59 is pivotally connected at bearing units 75 and 76 to the main frame 60 for angular movement about a horizontal transverse axis, generally parallel to the axis of the wheels of the rear wheel assembly 62. The bearing units 75 and 76 may incorporate a torsion bar or bars 77 arranged to normally hold the rear wheel assembly 62

-7-

at the desired normal height relative to the frame 60, and to permit limited up and down movement of the rear axle with respect to the frame 60 through the twisting of the torsion bars.

5 Alternatively, other forms of spring means, such as coil springs or leaf springs may be interposed between the frame 60 and the sub-frame 59 to control suspension movement between the rear axle assembly 62 and the main frame 60.

10 The front and rear axle assemblies 61 and 62 each incorporate drive axles 81 and 82, with respective differentials 83 and 84 coupled to the common gear box 85 by the drive shafts 86 and 87.

15 In this configuration, there is no suspension provided between the front axle and the frame 60, although if required, the forward converging portion 84 of the frame 60 could be pivotally connected to the frame 60 in a like manner to the connection between the sub-frame 59 and the main frame 60 at the rear of the vehicle as above described.

20 Referring now to Figure 2 of the drawings, there is shown a plan view of one end of a vehicle similar to that shown in Figure 1 but with the wheel and axle assembly modified to incorporate an independent suspension for each of the wheels. The forward portion of the chassis 40 incorporates two parallel cross members 41 and 42, interconnected by upwardly arched extensions 43 of the side rails 45 of the chassis 40.

25 The wheel and axle assembly 44 has a central transmission housing 48 which is pivotally mounted in the chassis 40 by the bearing units 47 and 48 which are arranged co-axially generally on the longitudinal axis of the vehicle chassis. As can be better seen in Figure 3, the transmission housing 48 has pivotally connected thereto respective pairs of suspension arms 53 and 54 which are also pivotally connected to the respective wheels 51, 52.

30 Respective drive shafts 52 and 53 respectively couple the wheels 51 and 52 to the transmission mechanism carried within the transmission housing 48. The springs 58 and 59

35

-8-

are coupled between the lower of the pairs of arms 49 and 50 and the brackets 60 and 61 projecting from the transmission housing 48. It will thus be seen that the wheels 51 and 52 are mounted to the transmission housing 48 by what is generally a conventional wishbone type suspension system. However, it is important to note that unlike in conventional vehicles, the springs 58 and 59 are not connected to the actual chassis or body of the vehicle, but are connected to the transmission housing 48 which is free to pivot relative to the chassis 40 about the longitudinal axis thereof as represented by bearing assemblies 46 and 47.

In the alternative construction as shown in Figure 4 of the drawings, there is provided a rigid elongated chassis 90 consisting of a pair of side rails 91 and 92 and a plurality of cross members as hereinafter described. The rear axle assembly 93 has a rigid drive axle 94 with wheels 95 at either end thereof. The A frame 96 is pivotally supported in the side rails 91 and 92 by bearing units 97 and 98, with the rear axle assembly 93 pivotally supported in the A frame by bearing units 99 and 100 for angular movement about the general longitudinal axis of the vehicle. At the rear, the A frame 96 is preferably connected through a ball or universal type joint 104 with the transverse leaf spring 101, which is connected by conventional shackle constructions 102 and 103 to the respective longitudinal rails of the chassis 91 and 92. The spring 101 thus provides a sprung suspension for the rear axle assembly 93.

The torsion shaft 105 is connected through a universal joint 80 to the rear axle assembly 93 so as to pivot therewith relative to the A frame 96. The pivot axis of the universal joint 80 is on the common axis of the bearing units 97, 98. At the forward end the torsion shaft 105 is rotatably supported in the bearing unit 81 in the cross member 106 and forward thereof carries the gear 107. The shaft 105 incorporates a sliding joint 82 of known construction to accommodate minor variations in the length of the shaft that arise as the A frame 96 pivots relative to the frame 90.

-9-

The front axle assembly 110 includes a drive axle 111 and wheels 112. The front axle assembly 110 includes a central rigid box member 113 which is pivotally supported by bearing units 114 and 115 in the respective cross members 116 and 117. The extension 118 of the member 113 is coupled by a belt or chain drive 121 to the torsion shaft 119 which is also supported in the cross members 116 and 106 and carries a gear 120 meshing with the gear 107 on the torsion shaft 105. The respective wheels 112 are connected by conventional double wishbone type suspension systems 122 to the central box member 113 of the front wheel assembly 110. Conventional coil springs or torsion bars are incorporated into the double wishbone assembly to provide independent sprung suspension for each of the front wheels 112. The construction of the double wishbone suspension is well-known in the vehicle industry and is therefore not further described herein.

In the above described construction, the respective front and rear wheel assemblies 93 and 110 are each provided with a sprung suspension and are each supported in the vehicle main frame 90 for angular movement relative thereto about a common longitudinal axis passing through the bearing units 99, 100, 114 and 115. The axle assemblies are interconnected by the control mechanism incorporating the belt drive 118, the torsion shafts 105 and 119, and the meshing spur gears 107 and 120. It is to be noted the pivot axis of the front and rear wheel assemblies is parallel to and offset from the axes of the torque shafts. This interconnection provides that a pivotal movement of one of the axle assemblies relative to the vehicle frame will induce an equal and opposite angular movement of the other wheel assembly relative to the vehicle frame.

Referring now to Figure 5 of the drawings, an alternative front axle and wheel assembly 20 is shown in elevation and it is to be understood that a rear axle and wheel assembly may also be of a similar construction. The transverse beam 21 is supported in a body such as the body

-10-

40 as previously described with reference to Figure 2. The arms 24 and 25 are pivotally connected at 26 and 27 respectively to the ends of the beam 21 for rotation relative thereto about axes parallel to the longitudinal axis of the bearings supporting the beam 21.

The spring assembly 28 has respective compression members 29 and 30 pivoted respectively at 31 and 32 to the arms 24 and 25. Supported between the compression members 29 and 30 is a compression spring 33 which under normal vehicle operating conditions will be in a compressed condition so that the axes of the wheels 22 and 23 are substantially horizontal when the vehicle is on a flat surface. It will be appreciated that the spring assembly 28 will transmit loads between the wheels 22 and 23 so that a deflection of one wheel in one direction will tend to induce a corresponding deflection of the other wheel in the opposite direction. Where such movement cannot take place either wholly or partly, there will be a resulting increase in the degree of compression of the spring 33. In normal operating conditions when one wheel strikes an obstacle, there may be a composite movement of that wheel rising and the other wheel lowering, and of the axle assembly rotating in the bearing 23 relative to the vehicle frame which will induce an opposite rotation of the other axle assembly. A conventional shock absorber device 34 is connected between the compression members 29 and 30 to function as a shock absorber in the conventional manner.

In the various practical arrangements described the invention has been applied to a land vehicle, however, it may also be applied to a water craft or vessel of the multi-hull or multi-float type. Thus, in the constructions described such as with reference to Fig. 1 of the drawings, the wheels can be replaced by floats.

35

-11-

THE CLAIMS DEFINING THE INVENTION ARE AS FOLLOWS:

1. A land vehicle comprising a load carrying body, two axle and wheel assemblies adapted to support the body to allow traversing thereof over land, said axle and wheel assemblies being spaced in opposite directions from the centre of gravity of the body and load carried thereby, each assembly being pivotally connected to the body for limited angular movement about a common or respective parallel axes extending generally in the longitudinal direction of the vehicle, and stabilising means interconnecting said two axle and wheel assemblies and including a torsion member rotatably supported by the body for movement about an axis not co-axial with both the axle and wheel assembly pivot axes, said torsion member being operatively coupled to the respective axle and wheel assemblies so that angular movement of either one of said assemblies relative to the body effects an opposite, preferably equal, angular movement of the other of said assembly relative to the body.

2. A vehicle as claimed in claim 1, wherein the stabilising means includes the torsion member supported by the body for relative angular movement about an axis extending generally in the longitudinal direction of the vehicle and laterally offset from the axis of rotation of at least one of the axle and wheel assemblies.

3. A vehicle as claimed in claim 1, wherein the stabilising means includes a first member supported in the body for relative angular movement about an axis substantially co-axial with the pivot axis of one of the wheel assemblies, and the torsion member is supported by the body for relative angular movement about an axis extending generally parallel to said first member and laterally offset from the axis thereof, said torsion member and first member being coupled so either one will rotate relative to the body in response to rotation of the other relative to the body.

-12-

4. A vehicle as claimed in claim 3, wherein the first member and the second member are coupled to each other to rotate in opposite directions and are coupled to the respective axle and wheel assemblies to rotate in the same direction thereas.

5. A vehicle as claimed in claim 2, where the torsion member is coupled at longitudinally spaced locations to the respective axle and wheel assemblies.

6. A vehicle as claimed in claim 1, wherein first and second members are supported co-axially by body for rotation relative to the body, the first and second members being respectively attached to a respective axle and wheel assembly to rotate therewith, each first and second member having a respective bevel gear mounted thereon to rotate therewith, and the torsion member is a further bevel gear mounted in drive engagement with the bevel gears on each of the first and second members and rotatably supported by the body for rotation about an axis inclined to the axis of rotation of the axle and wheel assemblies.

7. A vehicle as claimed in any one of the preceding claims wherein at least one of the axle and wheel assemblies comprises a rigid member pivotally connected to the body for angular movement about said longitudinal axis, a pair of laterally spaced ground engaging wheels one on either side of said rigid member and connected to said rigid member by respective arm assemblies, each arm assembly being connected to the rigid member for angular movement relative thereto in a substantially vertical plane to permit raising and lowering of the wheel relative to the body, and the wheel being rotatable relative to the arm assembly about a horizontal axis generally transverse to said longitudinal axis of the body.

-13-

8. A vehicle as claimed in claim 7, wherein respective resilient means are interposed between each arm assembly and the rigid member and arranged to urge the wheel in a direction to engage the ground.
9. A vehicle as claimed in claim 7, wherein resilient means are interposed between the two arm assemblies and arranged to urge both wheels in a direction to engage the ground.
10. A vehicle as claimed in any one of claims 1 to 6, wherein the body includes a longitudinally extending main frame and a sub-frame pivotally connected to the main frame about and transverse to the main frame, one of said axle and wheel assemblies being mounted in said sub-frame for angular movement about said longitudinal axis, and resilient means operatively interposed between said sub-frame and main frame to urge the sub-frame in a direction so the wheels of said axle and wheel assembly to engage the ground.
11. A vehicle as claimed in claim 10, wherein the resilient means is a leaf spring.
12. A vehicle as claimed in claim 10, wherein the resilient means is one or more torsion bars.
13. A vehicle comprising a load carrying body, two float assemblies adapted to support the body to allow traversing thereof over water, said float assemblies being spaced in opposite directions from the centre of gravity of the body and load carried thereby, each assembly being pivotally connected to the body for limited angular movement about a common or respective parallel axes extending generally in the longitudinal direction of the vehicle, and stabilising means interconnecting said two float assemblies

-14-

and including a torsion member rotatably supported by the body for movement about an axis not co-axial with both the float assembly pivot axes, said torsion member being operatively coupled to the respective float assemblies so that angular movement of either one of said assemblies relative to the body effects an opposite, preferably equal, angular movement of the other of said assembly relative to the body.

14. A vehicle as claimed in claim 13, wherein the stabilising means includes a first member supported in the body for relative angular movement about an axis substantially co-axial with the pivot axis of one of the float assemblies, and the torsion member is supported by the body for relative angular movement about an axis extending generally parallel to said first member and laterally offset from the axis thereof, said torsion member and first member being coupled so either one will rotate relative to the body in response to rotation of the other relative to the body.

Fig .1.

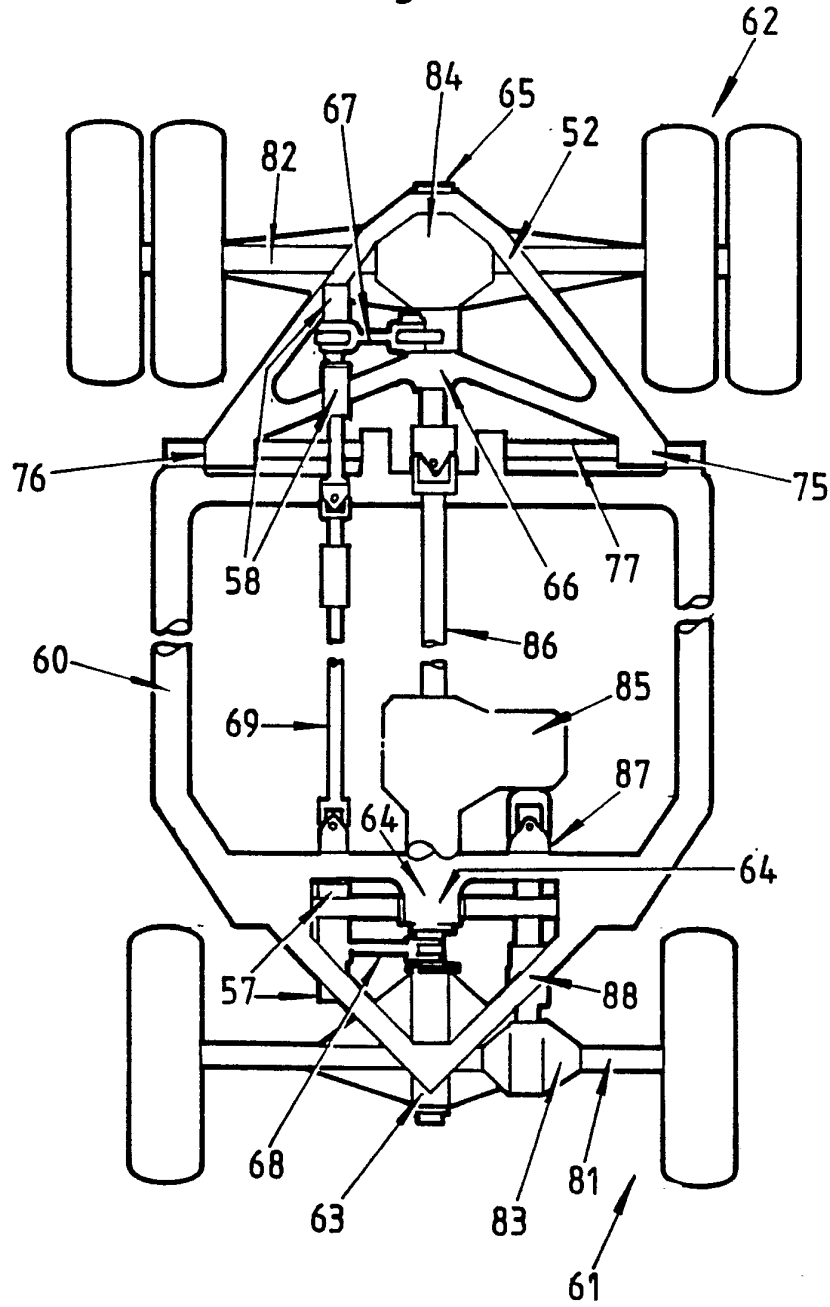

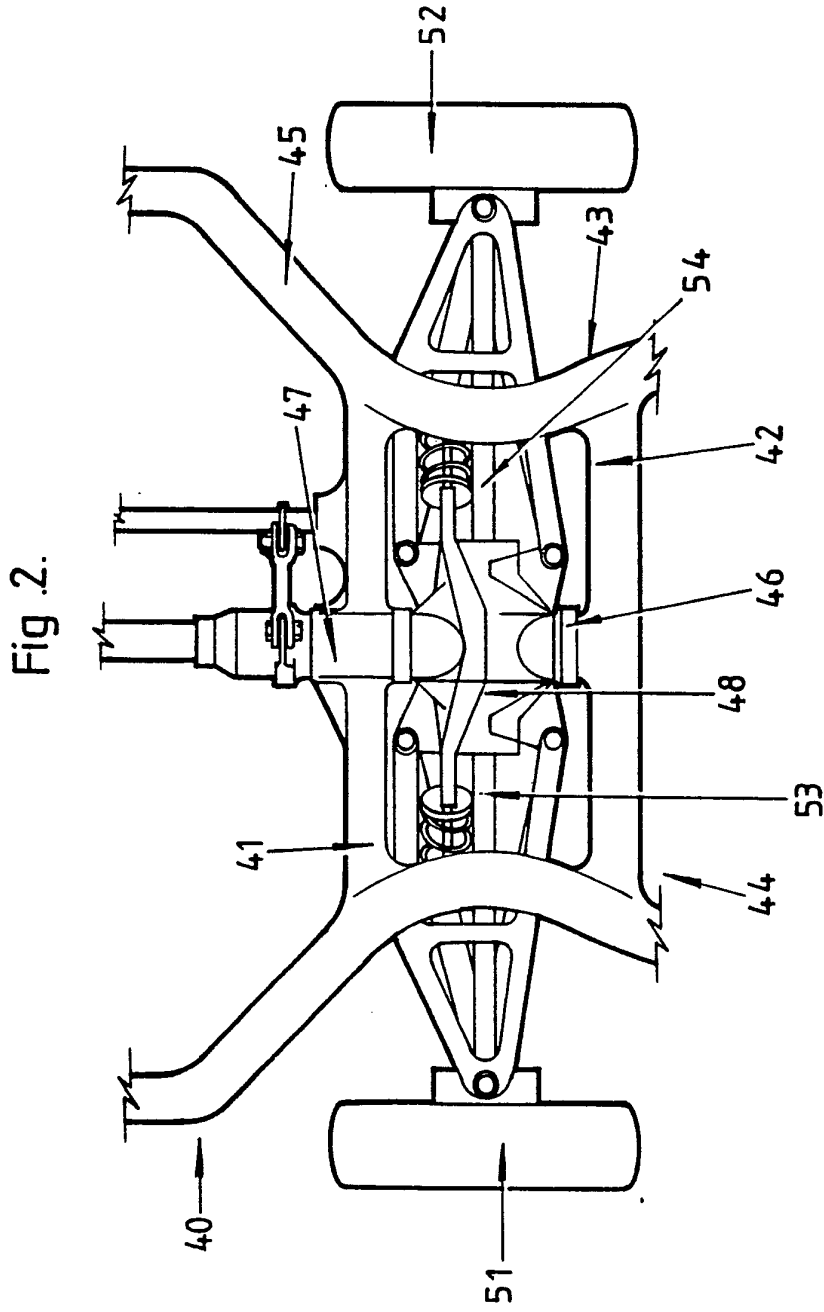

Fig. 3.

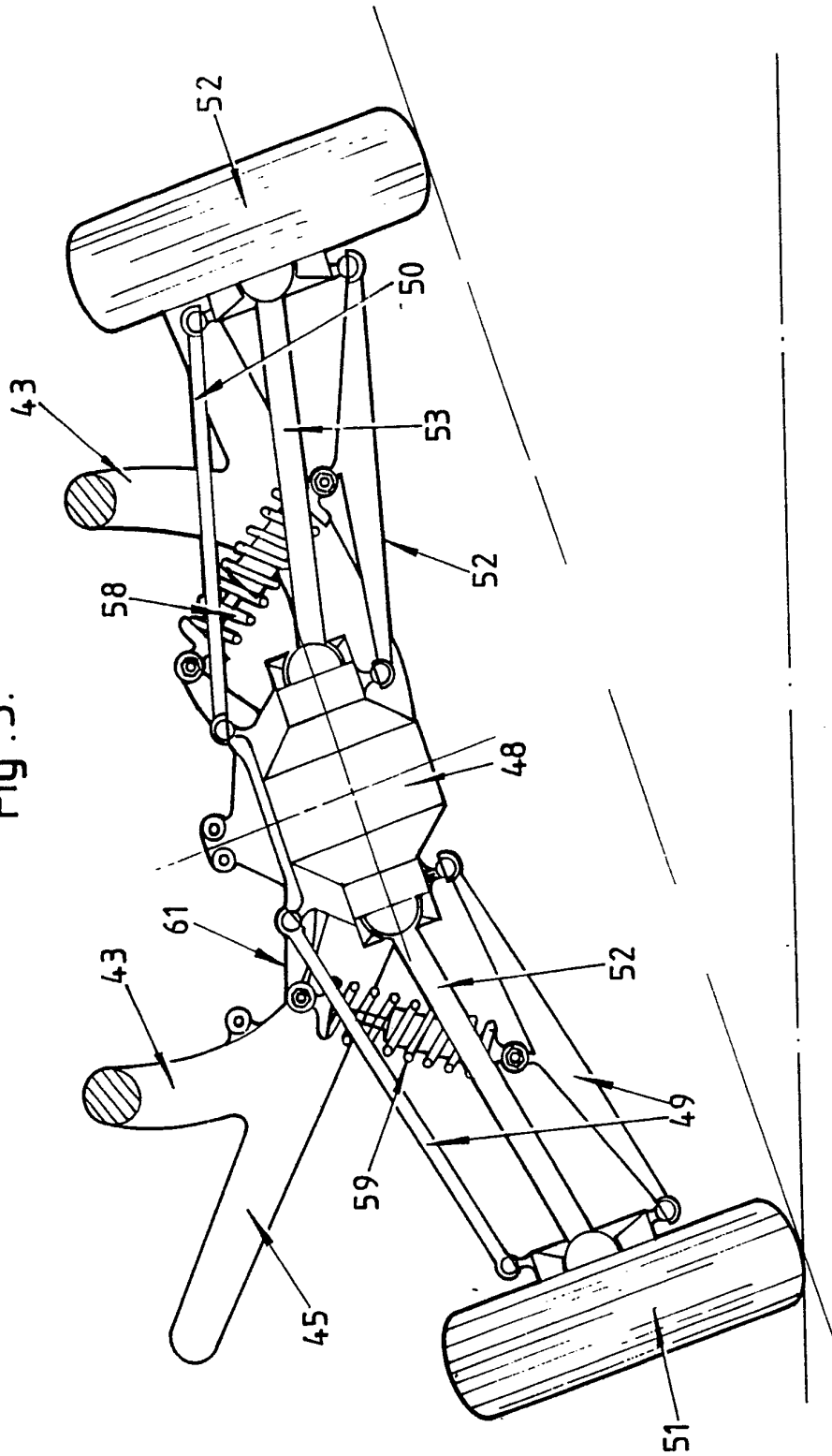

Fig 4.

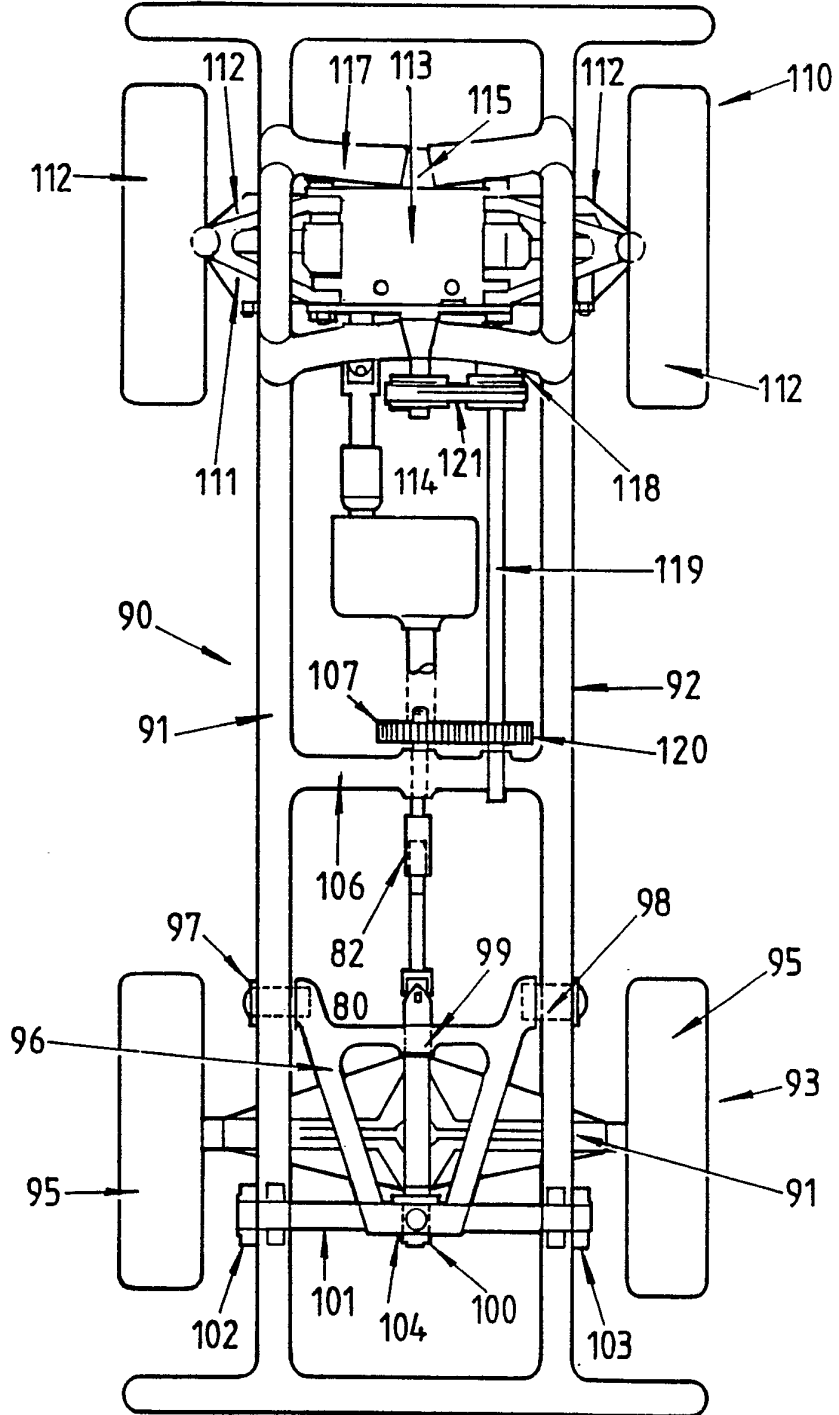
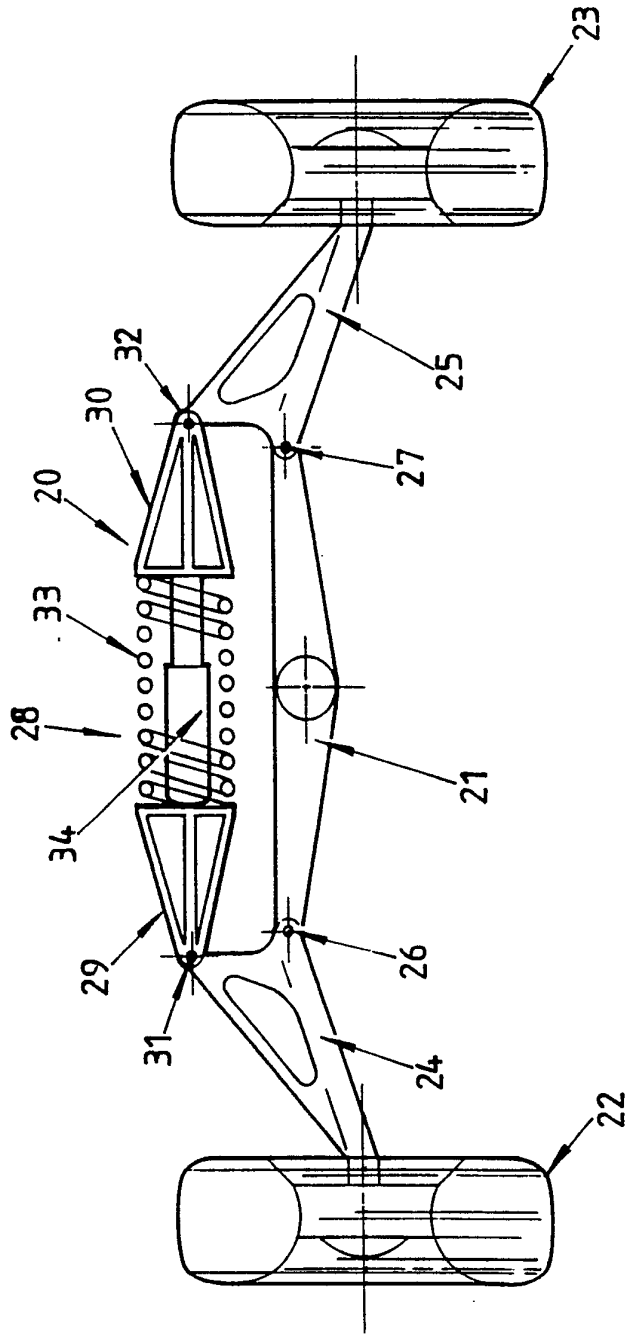

Fig. 5.



INTERNATIONAL SEARCH REPORT

International Application No. **PCT/AU 90/00146**

I. CLASSIFICATION OF SUBJECT MATTER (if several classification symbols apply, indicate all) 6		
According to International Patent Classification (IPC) or to both National Classification and IPC		
Int. Cl. ⁴ B60G 21/04		
II. FIELDS SEARCHED		
Minimum Documentation Searched 7		
Classification System	Classification Symbols	
IPC	B60G 21/04, 19/02	
Documentation Searched other than Minimum Documentation to the Extent that such Documents are Included in the Fields Searched 8		
AU: IPC as above, B63B 39/00, 1/40		
III. DOCUMENTS CONSIDERED TO BE RELEVANT 9		
Category*	Citation of Document, ¹¹ with indication, where appropriate, of the relevant passages 12	Relevant to Claim No 13
X,Y	FR,A, 741583 (RONDIER) 14 February 1933 (14.02.33) See page 1 line 39 to page 2 line 95	(1-2)
A	FR,A 997,849 (SAINTENOY) 10 January 1952 (10.01.52)	
X,Y	FR,A 2161017 (SMALLFRY LIMITED) 6 July 1973 (06.07.73) See page 2 lines 12 to page 3 line 21 page 5 line 15 to page 6 line 19 and fig 2.	(1-2)
X	FR,A, 865881 (SALMON) 6 June 1941 (06.06.41) See page 2 lines 37 to 83 and figs 1,3 and 7	(1-8)
X	AU,B, 47683/79 (526530) (DE PINGON) 13 December 1979 (13.12.79) See page 5, lines 1 to 17	(13)
<p>* Special categories of cited documents: 10</p> <p>"A" document defining the general state of the art which is not considered to be of particular relevance</p> <p>"E" earlier document but published on or after the international filing date</p> <p>"L" document which may throw doubts on priority claim(s) or which is cited to establish the publication date of another citation or other special reason (as specified)</p> <p>"O" document referring to an oral disclosure, use, exhibition or other means</p> <p>"P" document published prior to the international filing date but later than the priority date claimed</p> <p>"T" later document published after the international filing date or priority date and not in conflict with the application but cited to understand the principle or theory underlying the invention</p> <p>"X" document of particular relevance; the claimed invention cannot be considered novel or cannot be considered to involve an inventive step</p> <p>"Y" document of particular relevance; the claimed invention cannot be considered to involve an inventive step when the document is combined with one or more other such documents, such combination being obvious to a person skilled in the art.</p> <p>"&" document member of the same patent family</p>		
IV. CERTIFICATION		
Date of the Actual Completion of the International Search 2 AUGUST 1990 (02.08.90)	Date of Mailing of this International Search Report 8 August 1990	
International Searching Authority Australian Patent Office	Signature of Authorized Officer <i>P.J. White</i> P.J. WHITE	

ANNEX TO THE INTERNATIONAL SEARCH REPORT ON
INTERNATIONAL APPLICATION NO. PCT/AU 90/00146

This Annex lists the known "A" publication level patent family members relating to the patent documents cited in the above-mentioned international search report. The Australian Patent Office is in no way liable for these particulars which are merely given for the purpose of information.

Patent Document
Cited in Search
Report

Patent Family Members

AU 47683/79	EP 16017	ES 481319	FR 2427942
	GR 65193	IN 152388	IT 1118724
	JP 55500560	NL 7904537	NO 791911
	PT 69689	WO 8000018	MX 146681

FR 2161017	DE 2256934	IT 975827	JP 49055019
	ZA 7208206		

END OF ANNEX