



US 20080058785A1

(19) **United States**

(12) **Patent Application Publication**
Boyden et al.

(10) **Pub. No.: US 2008/0058785 A1**

(43) **Pub. Date: Mar. 6, 2008**

(54) **AUTOFLUORESCENT IMAGING AND TARGET ABLATION**

(75) Inventors: **Edward S. Boyden**, Cambridge, MA (US); **Roderick A. Hyde**, Redmond, WA (US); **Muriel Y. Ishikawa**, Livermore, CA (US); **Eric C. Leuthardt**, St. Louis, MO (US); **Nathan P. Myhrvold**, Medina, WA (US); **Dennis J. Rivet**, Portsmouth, VA (US); **Thomas Allan Weaver**, San Mateo, CA (US); **Lowell L. Wood JR.**, Bellevue, WA (US)

Correspondence Address:
SEARETE LLC
CLARENCE T. TEGREENE
1756 - 114TH AVE., S.E.
SUITE 110
BELLEVUE, WA 98004 (US)

(73) Assignee: **Searete LLC, a limited liability corporation of the State of Delaware**

(21) Appl. No.: **11/895,560**

(22) Filed: **Aug. 24, 2007**

Related U.S. Application Data

(63) Continuation-in-part of application No. 11/403,230, filed on Apr. 12, 2006.
Continuation-in-part of application No. 11/645,357, filed on Dec. 21, 2006.

Publication Classification

(51) **Int. Cl.**
A61B 18/18 (2006.01)
(52) **U.S. Cl.** **606/13**

(57) **ABSTRACT**

Apparatus, devices, methods, systems, computer programs and computing devices related to autofluorescent imaging and ablation are disclosed.

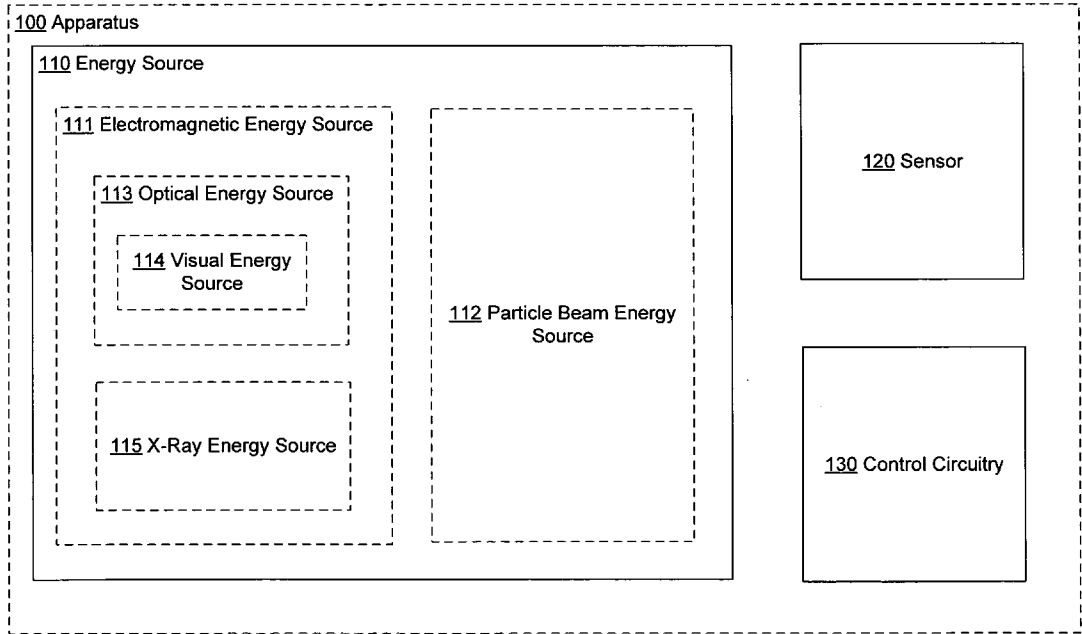

FIG. 1

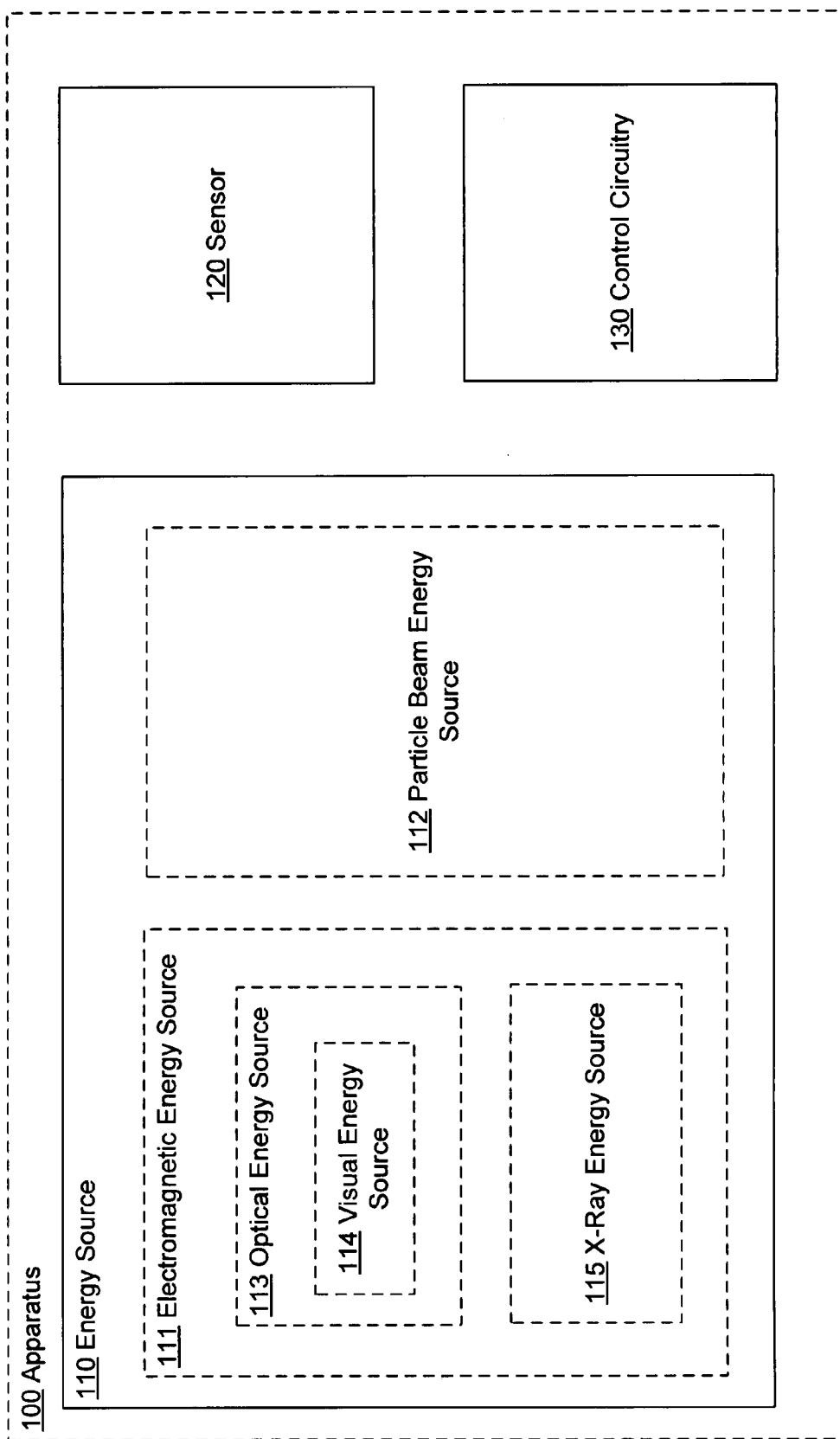

FIG. 2

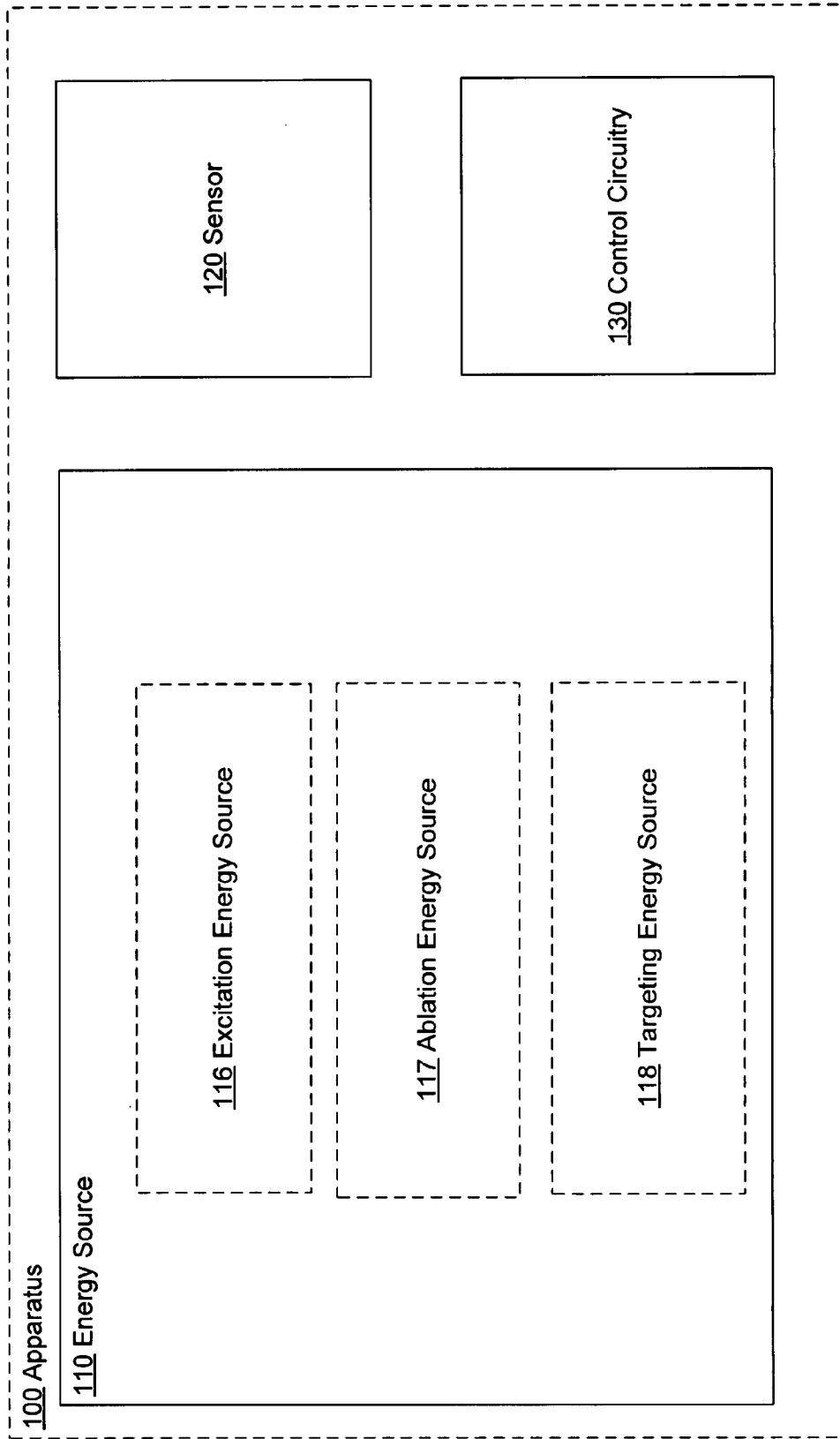

FIG. 3

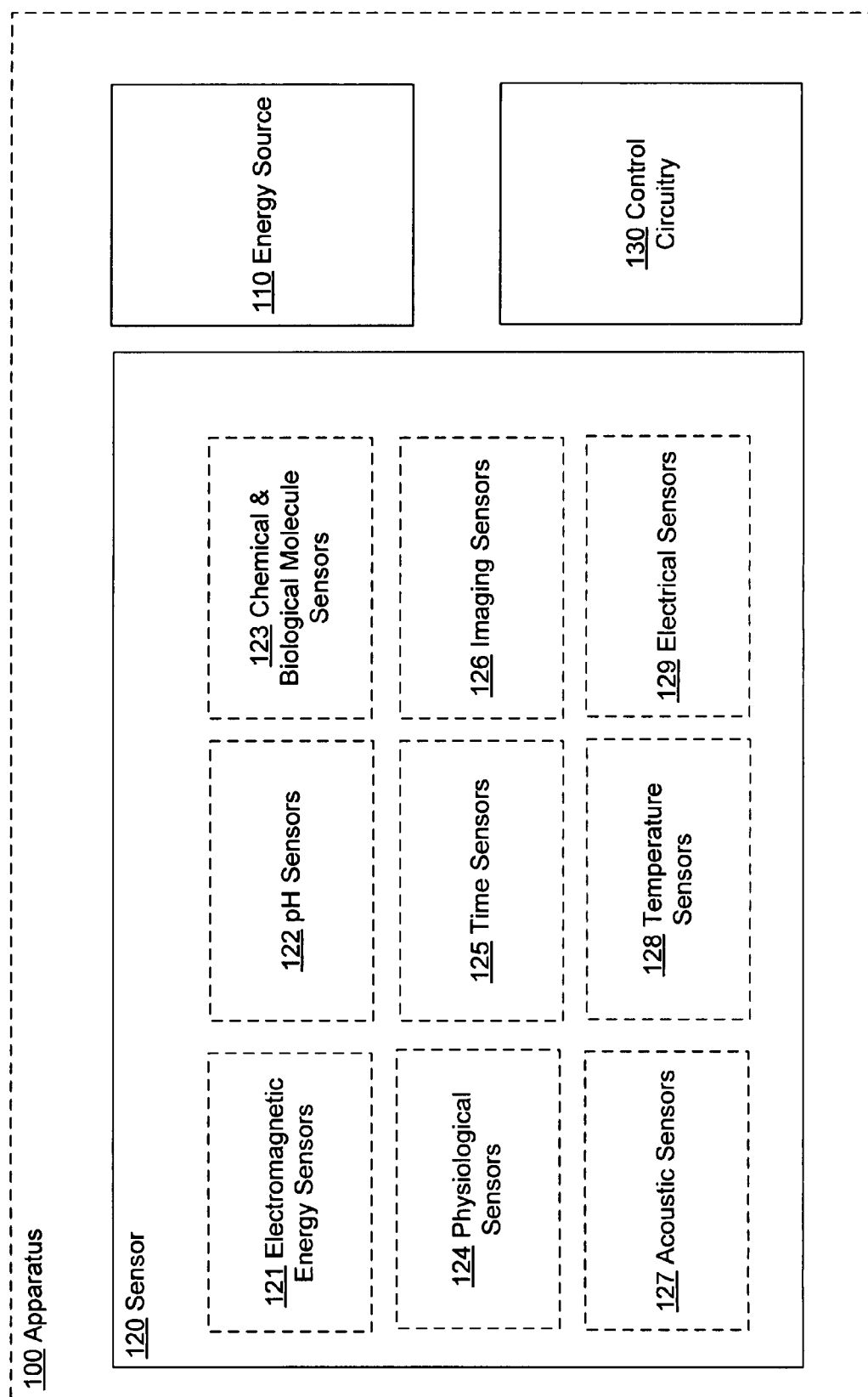

FIG. 4

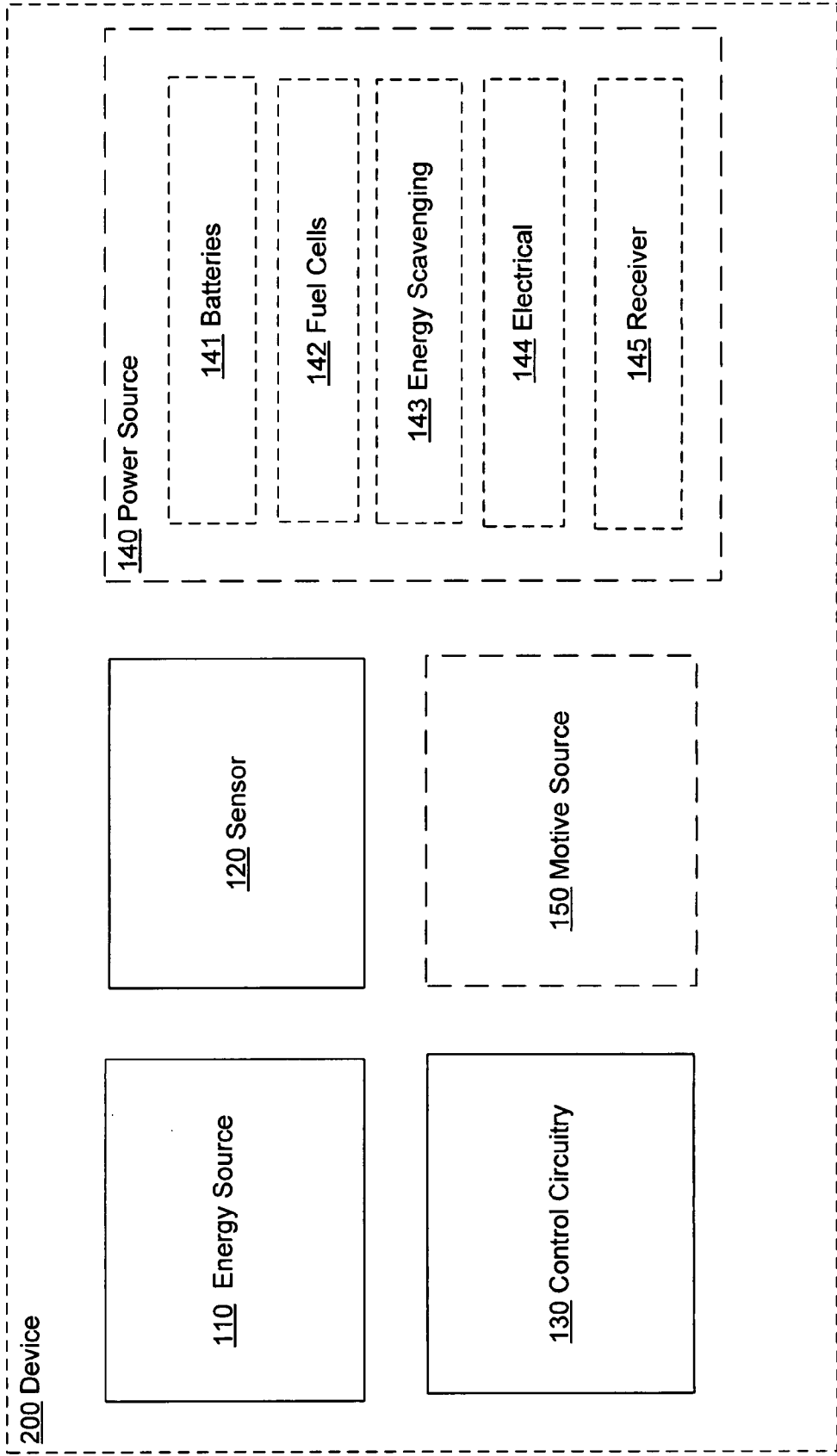

FIG. 5

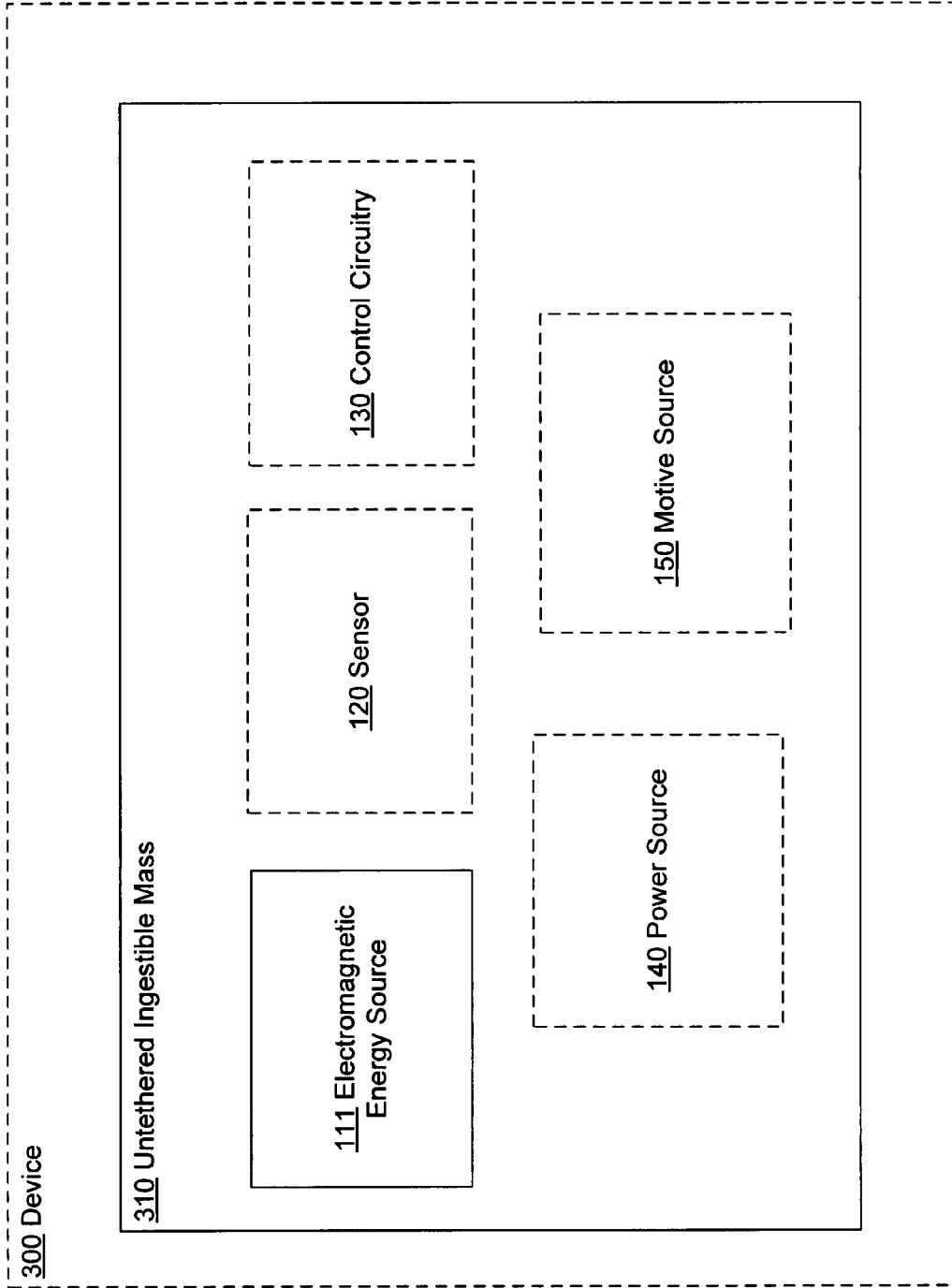

FIG. 6

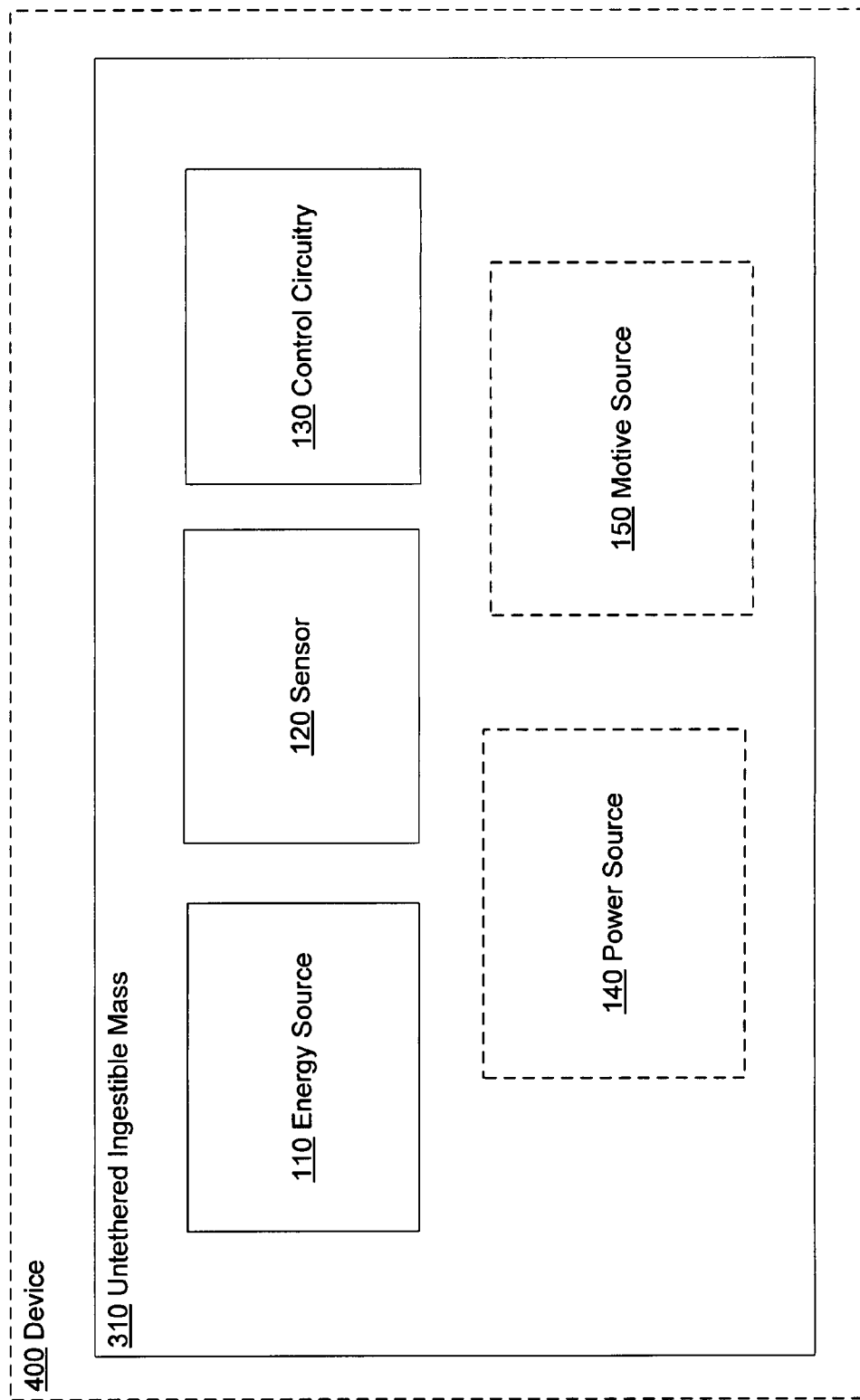

FIG. 7

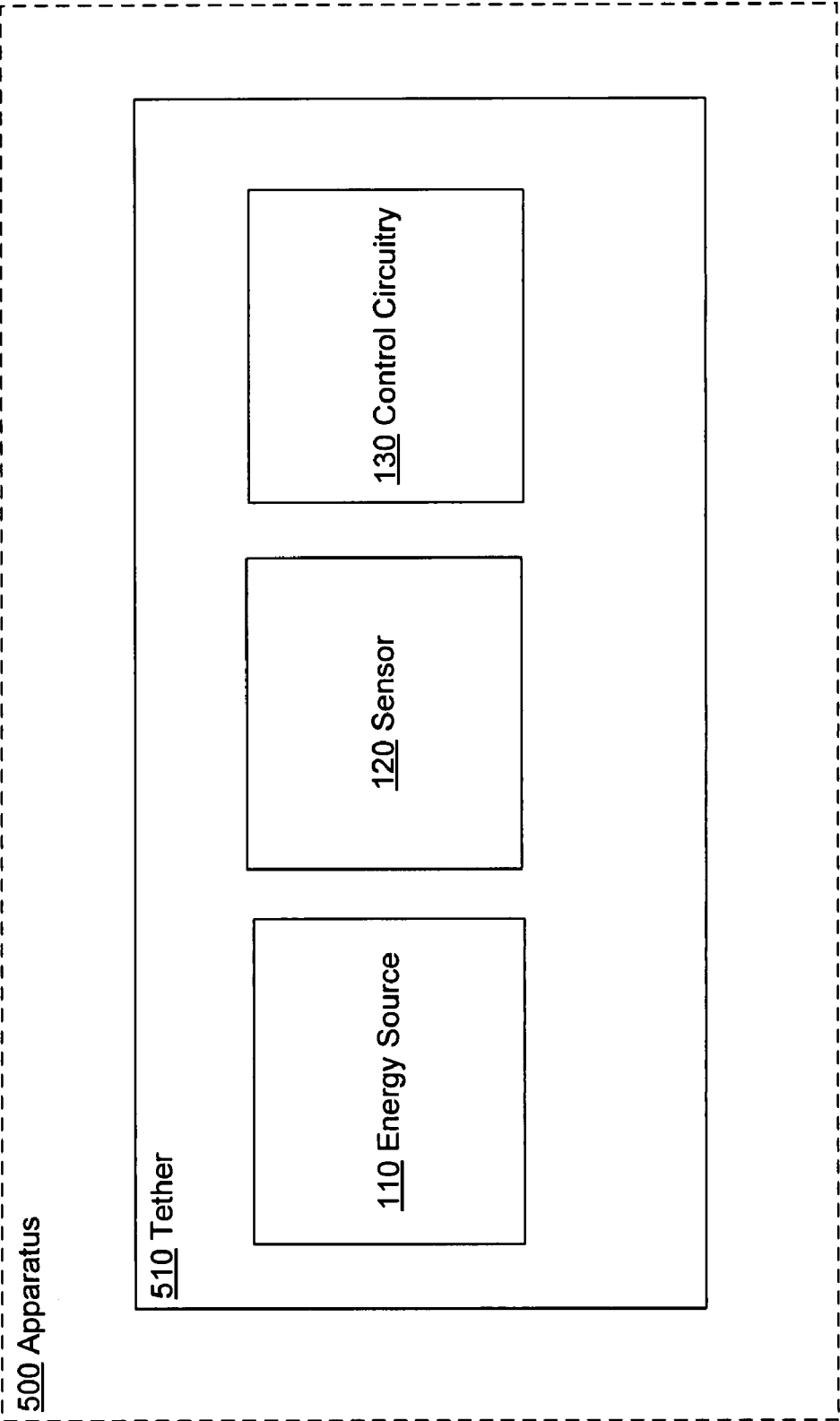

FIG. 8

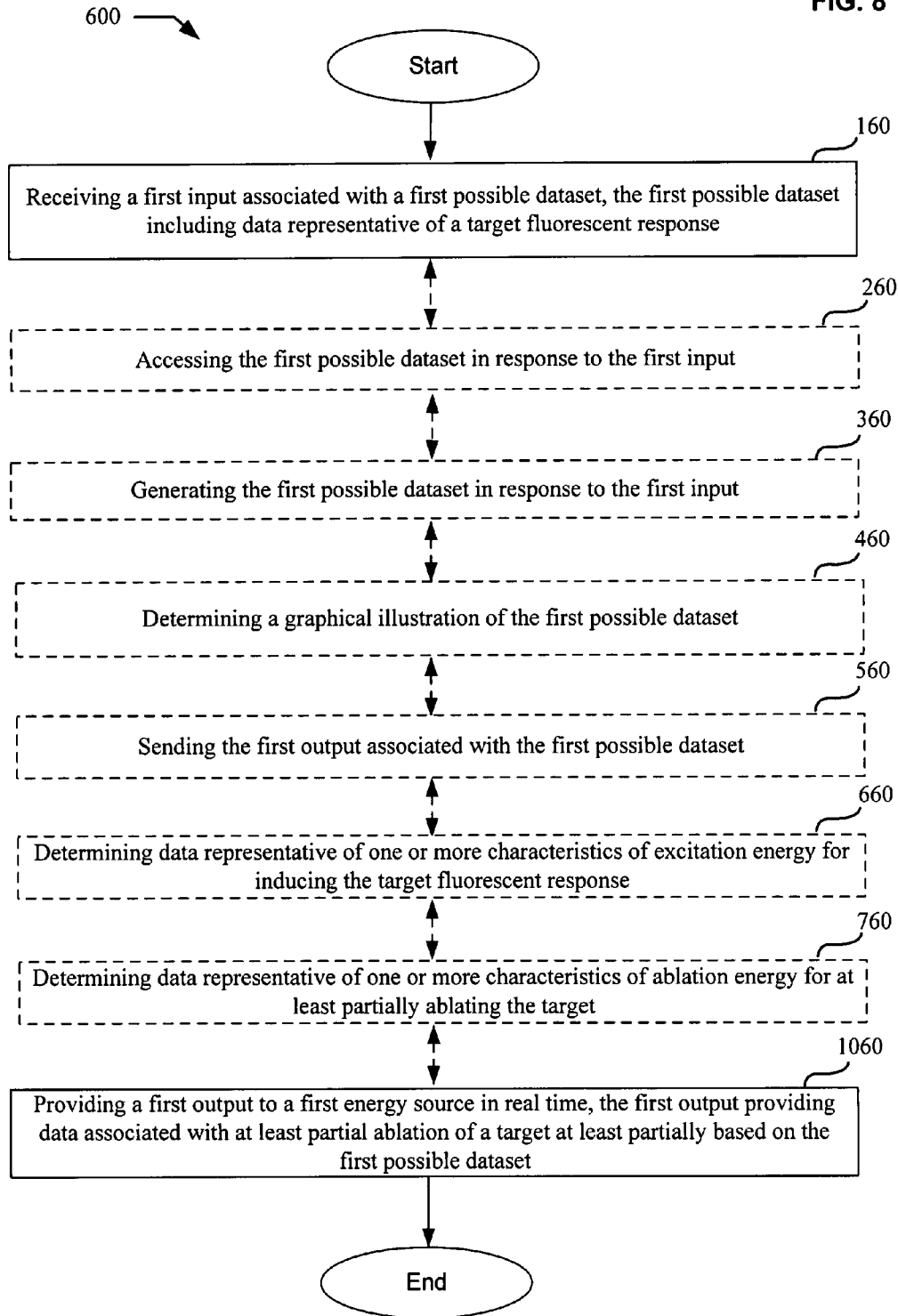
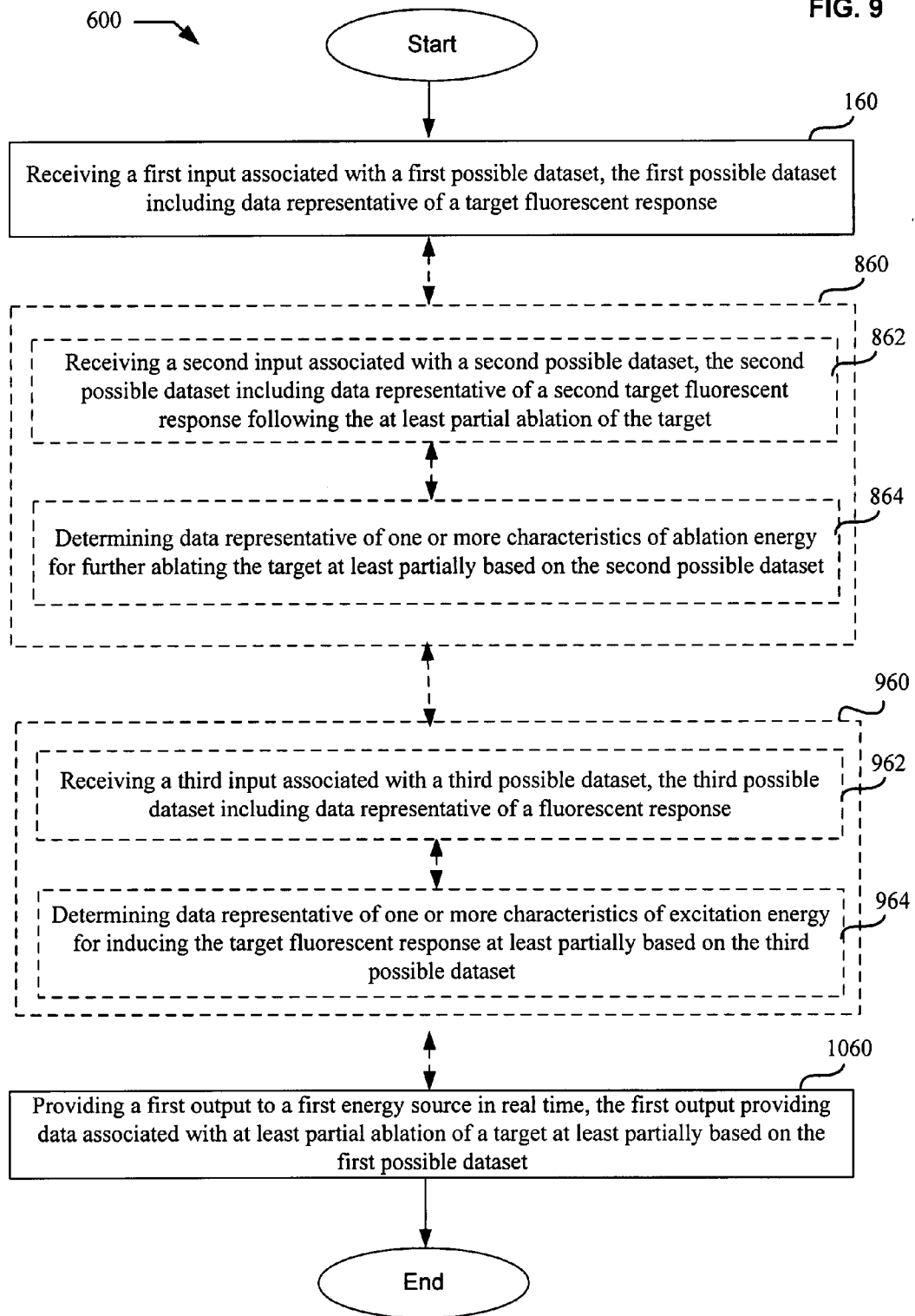

FIG. 9



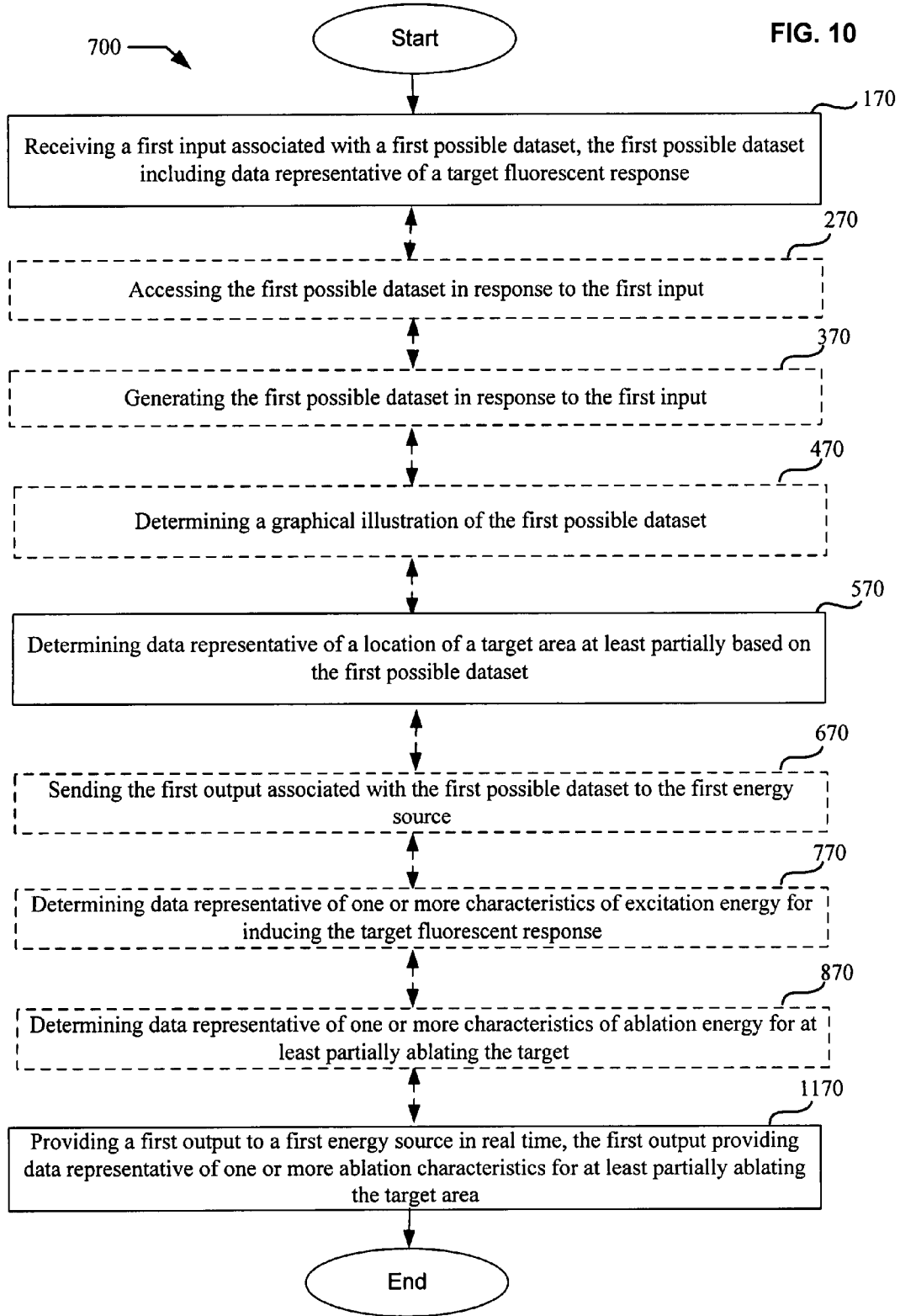

FIG. 11

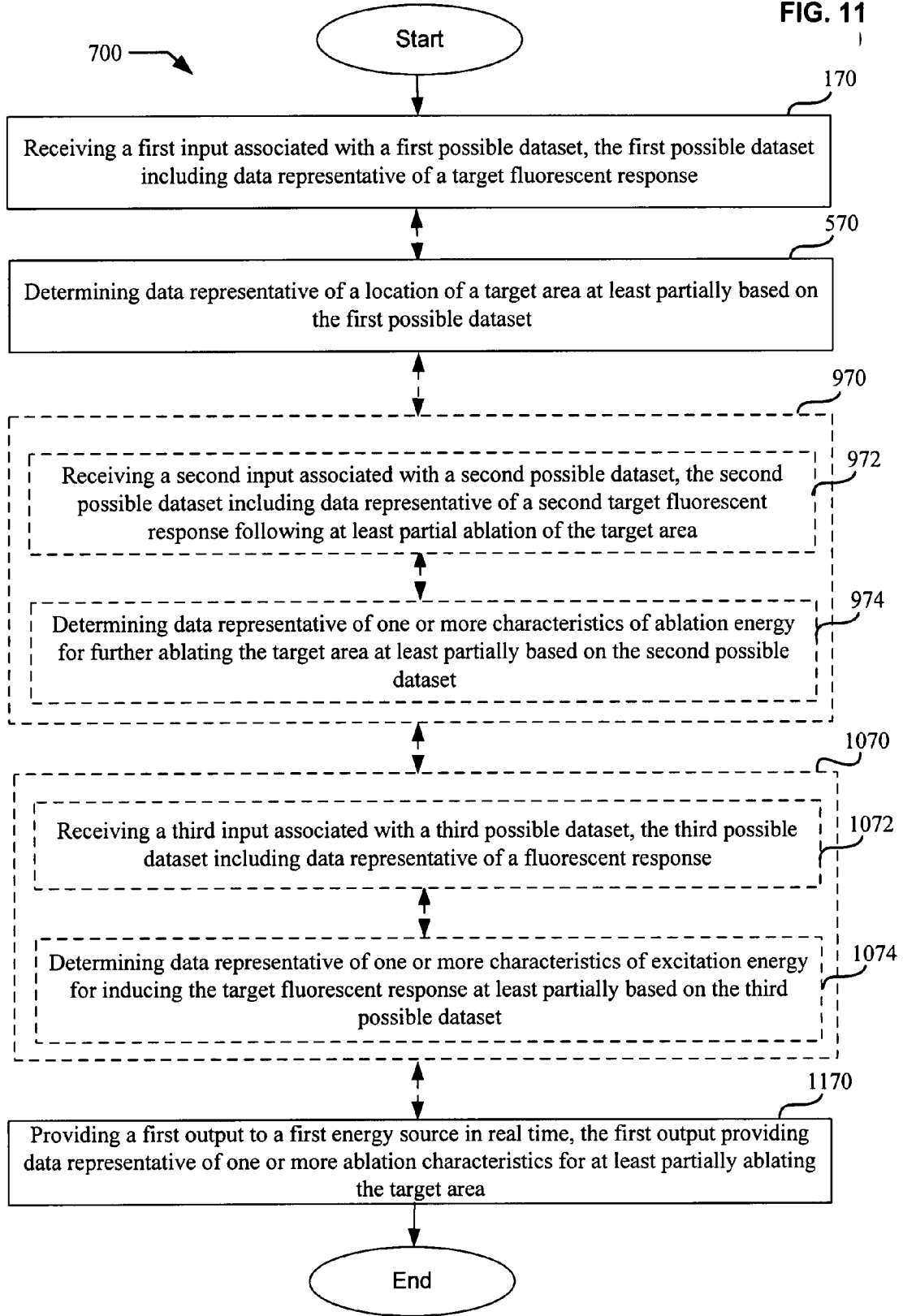

FIG. 12

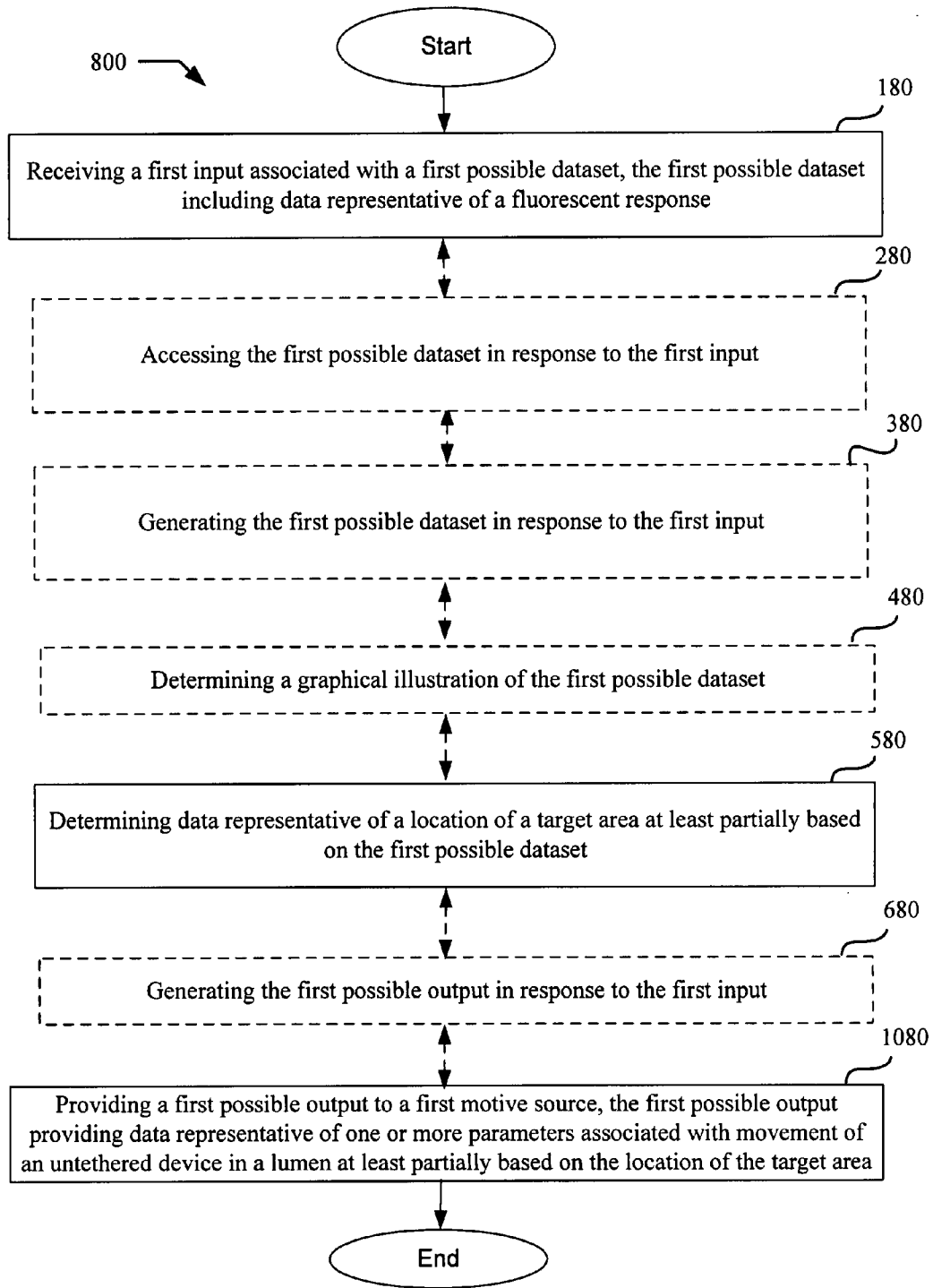

FIG. 13

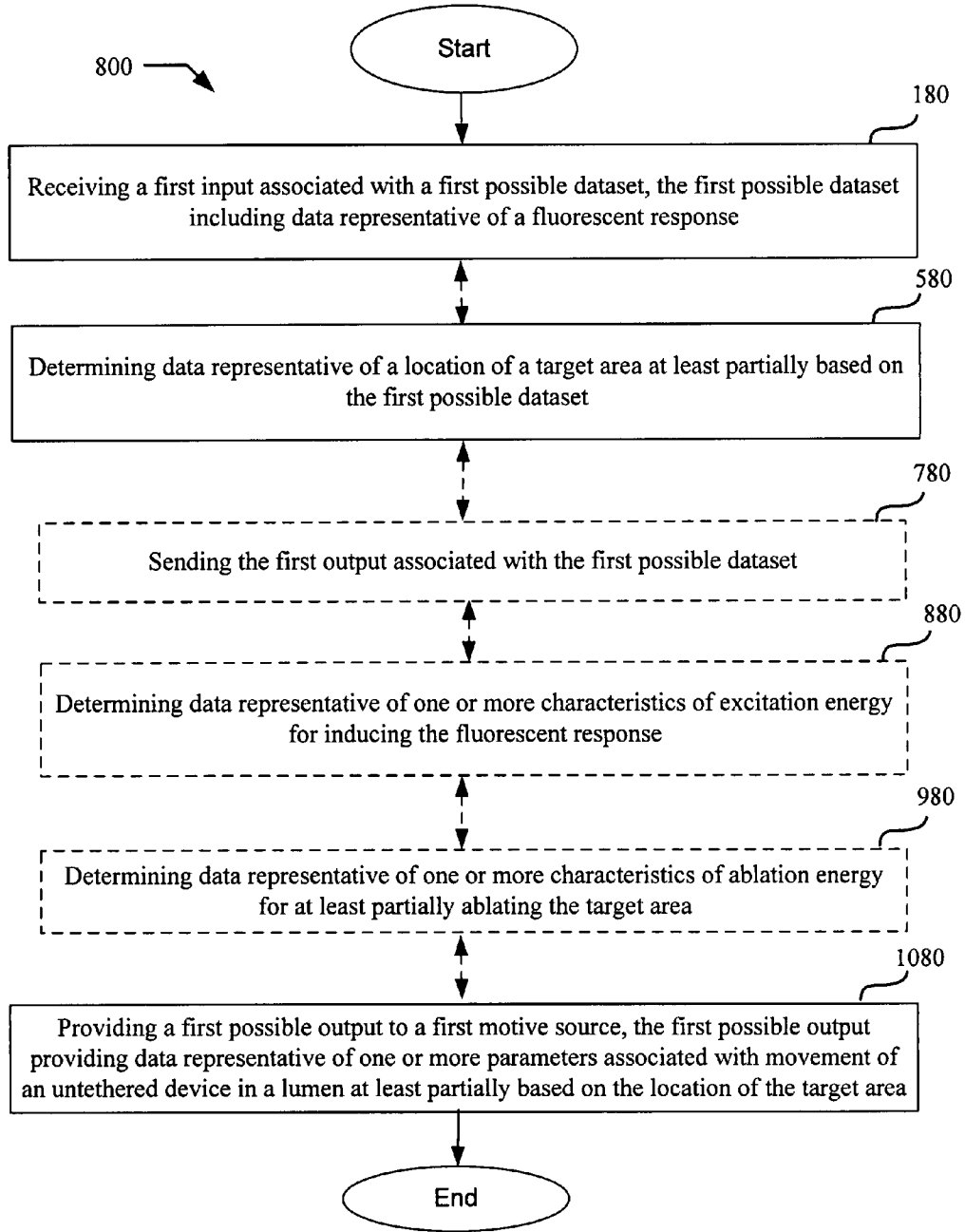

FIG. 14

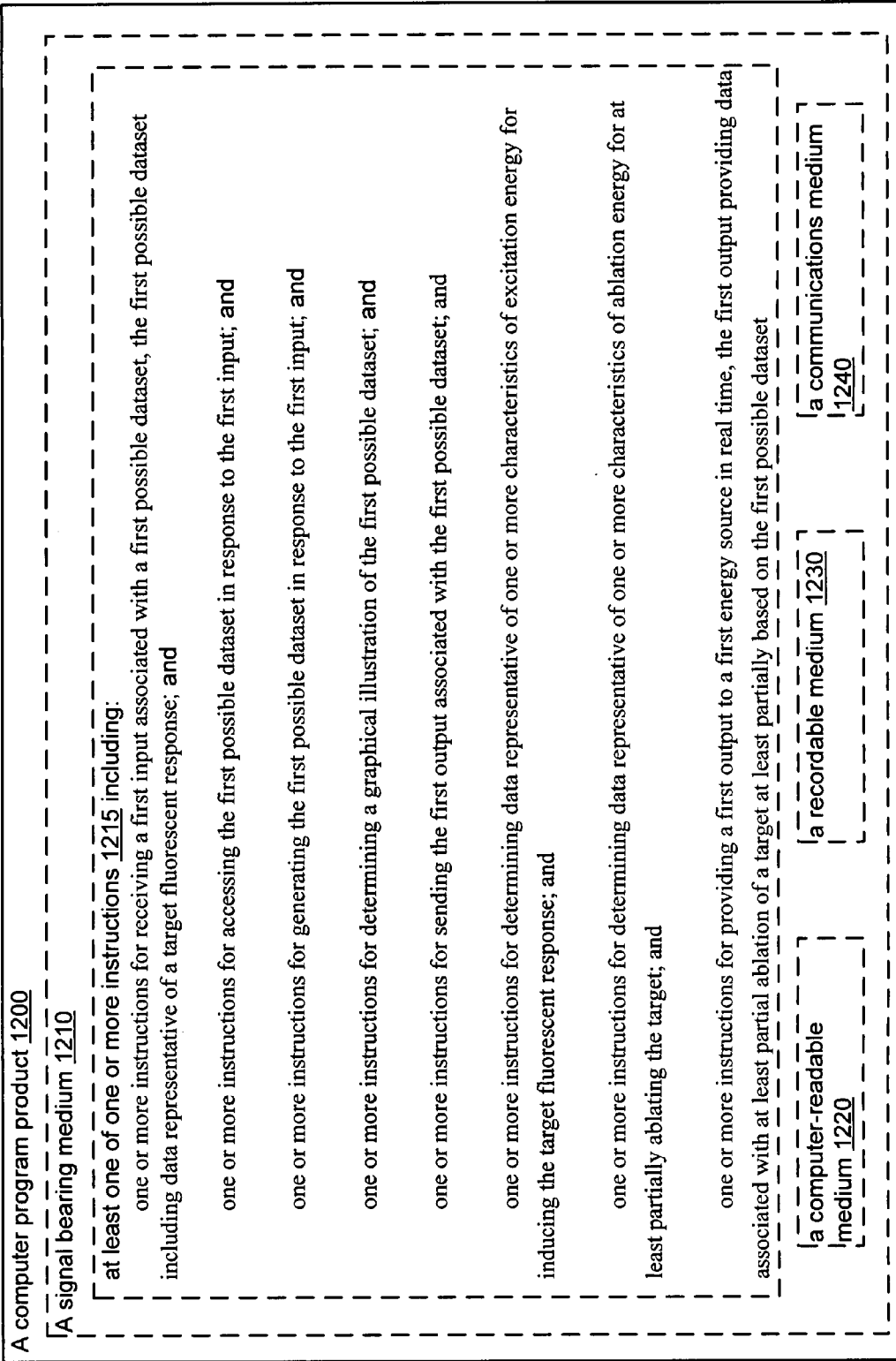

FIG. 15

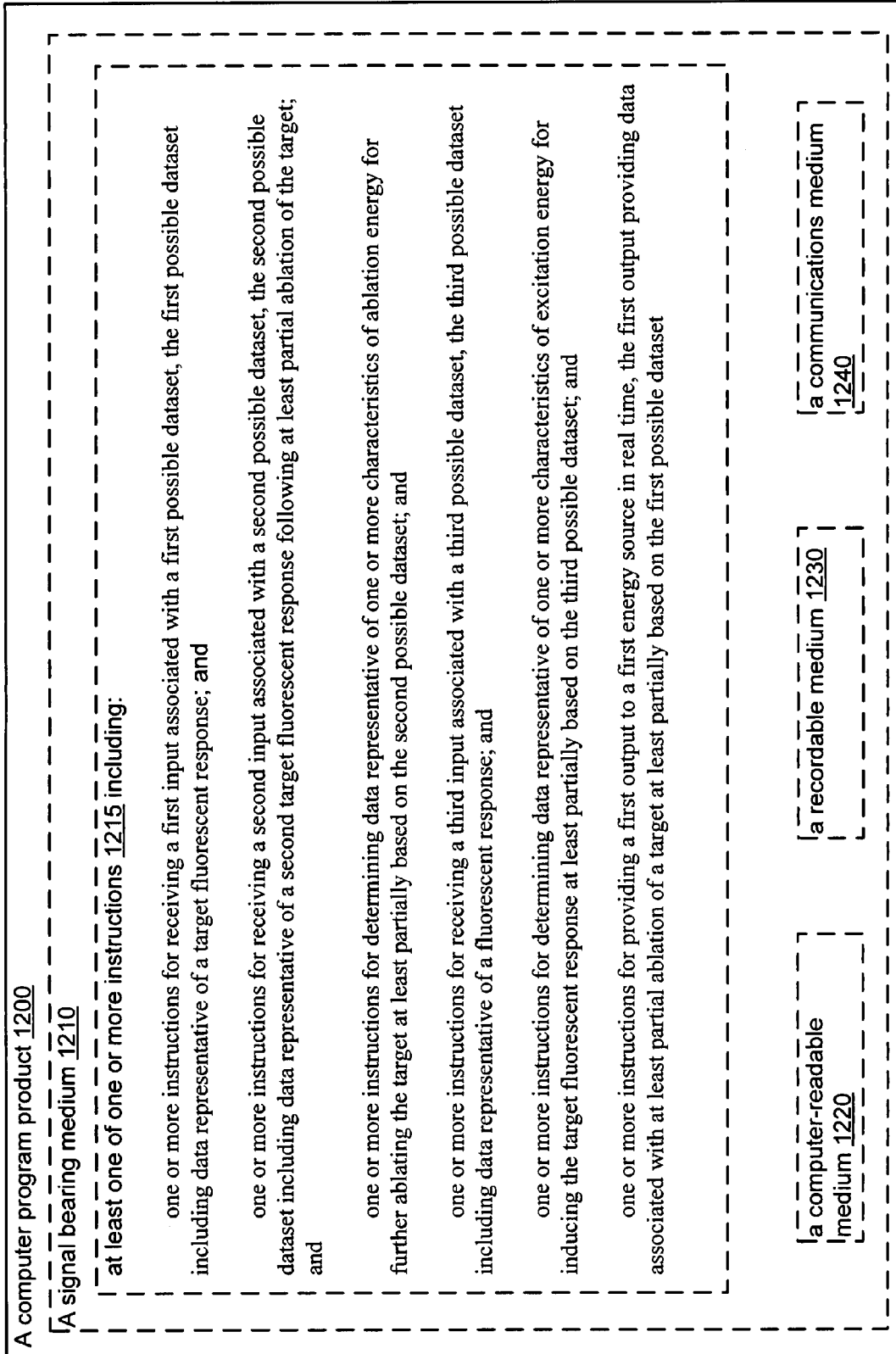

FIG. 16

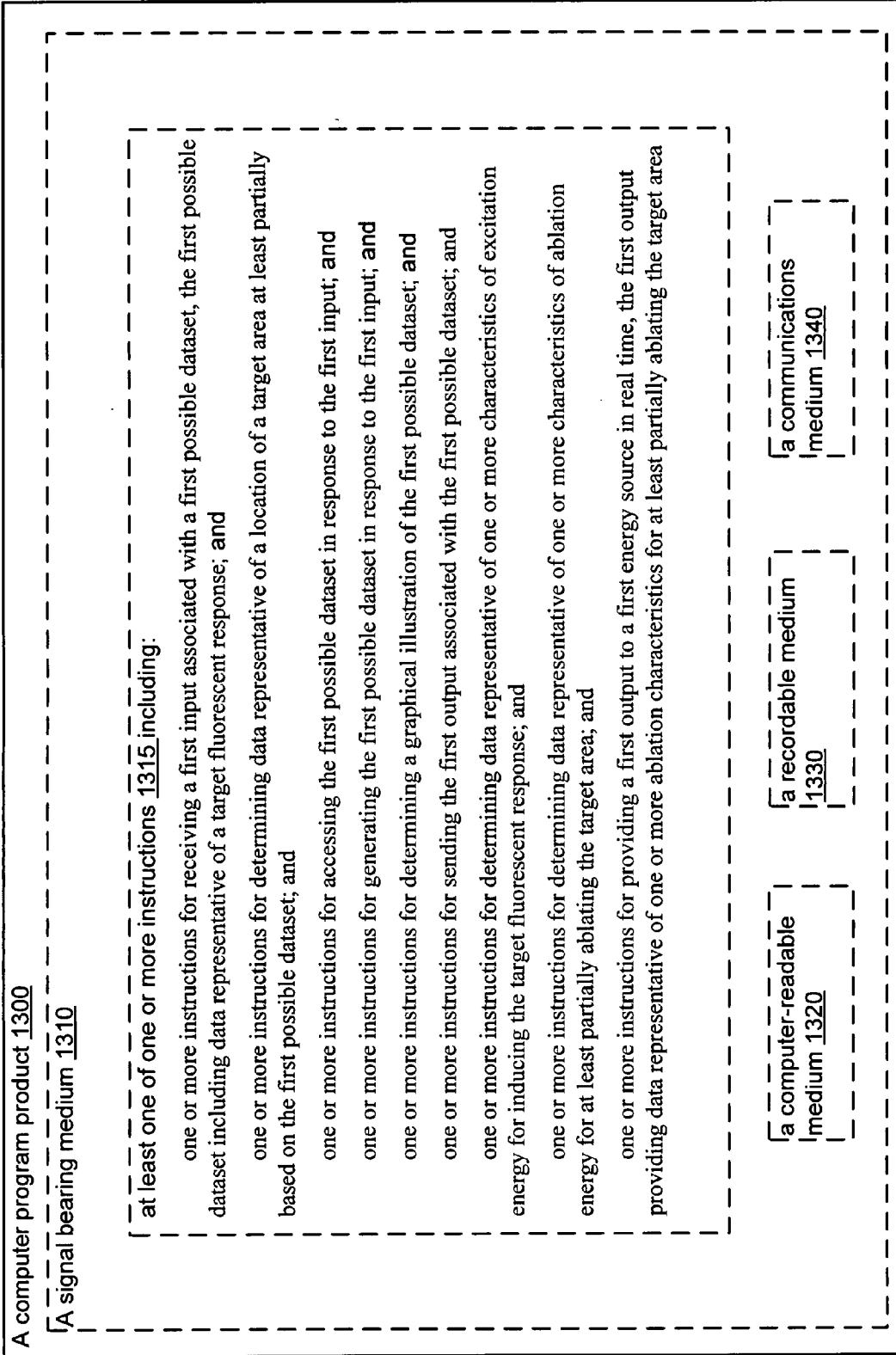

FIG. 17

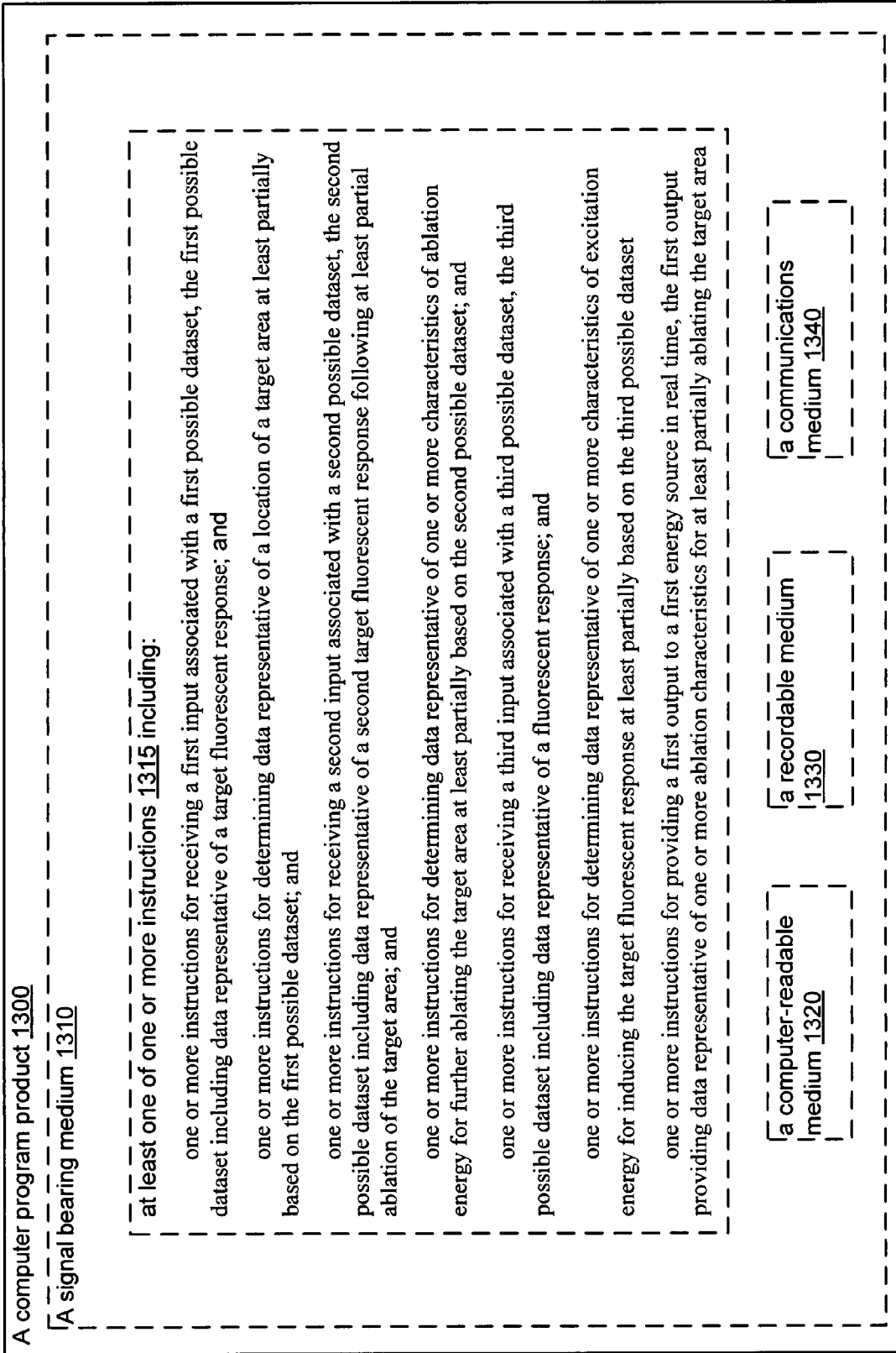

FIG. 18

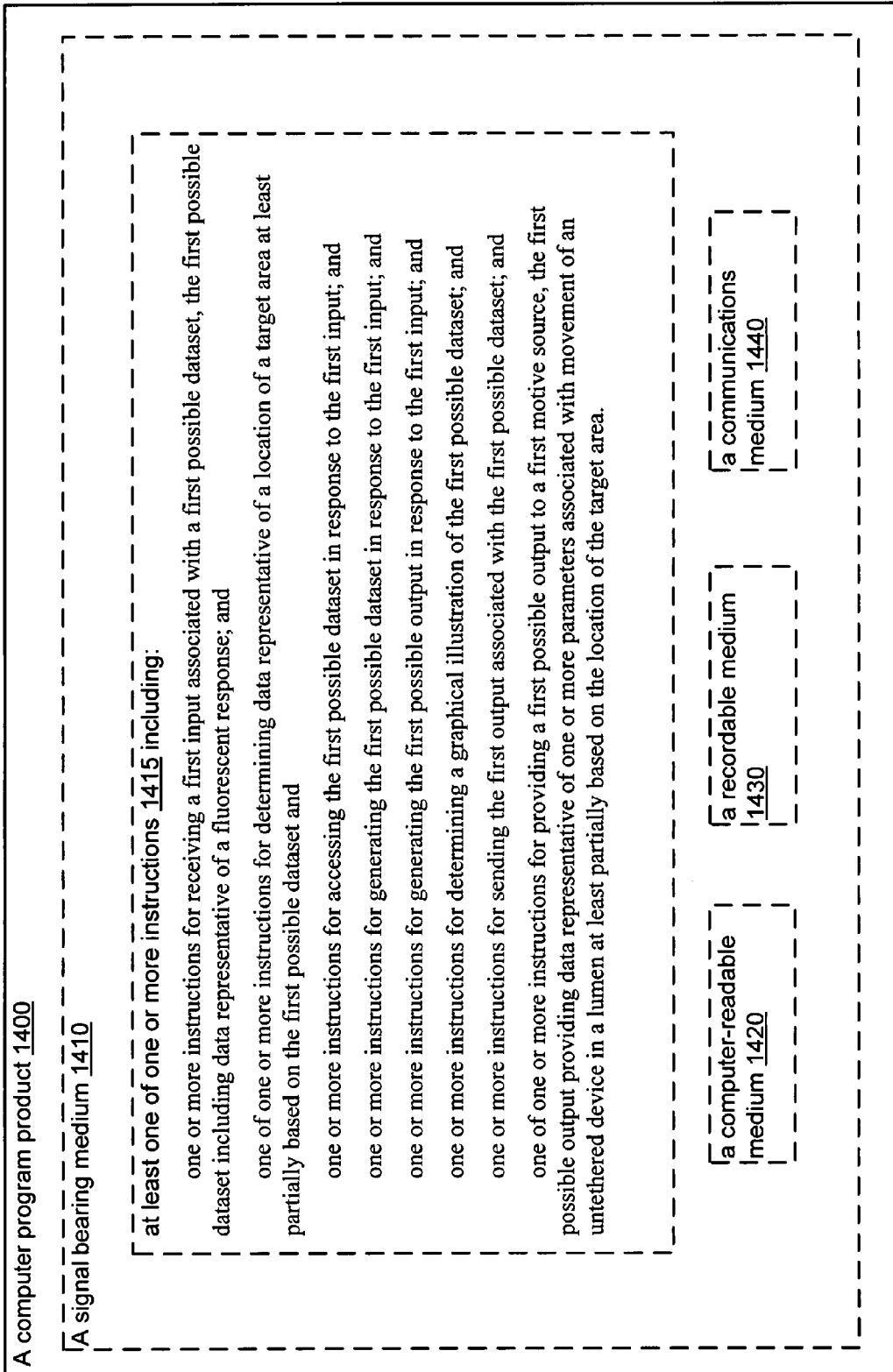

FIG. 19

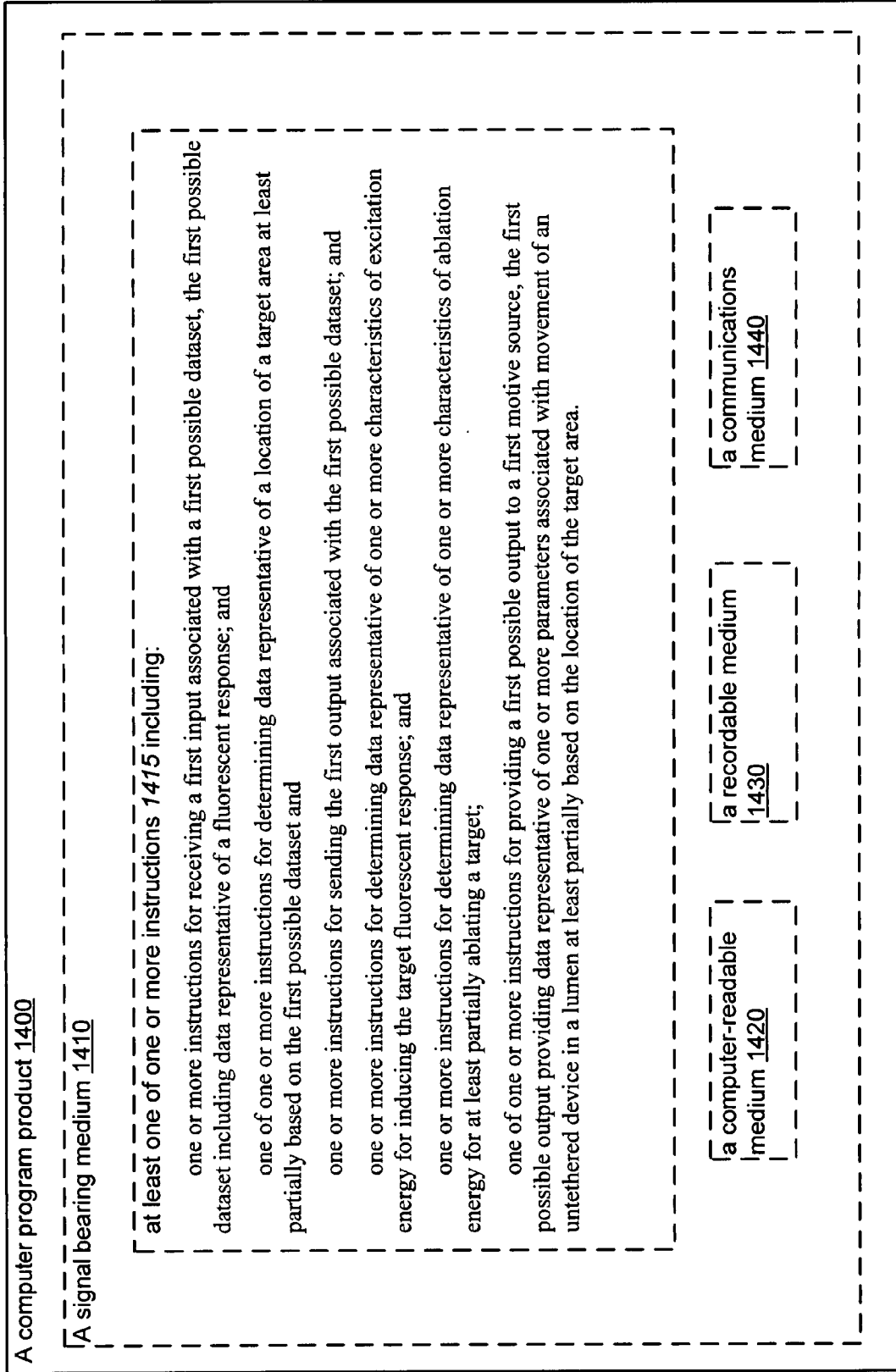

FIG. 20

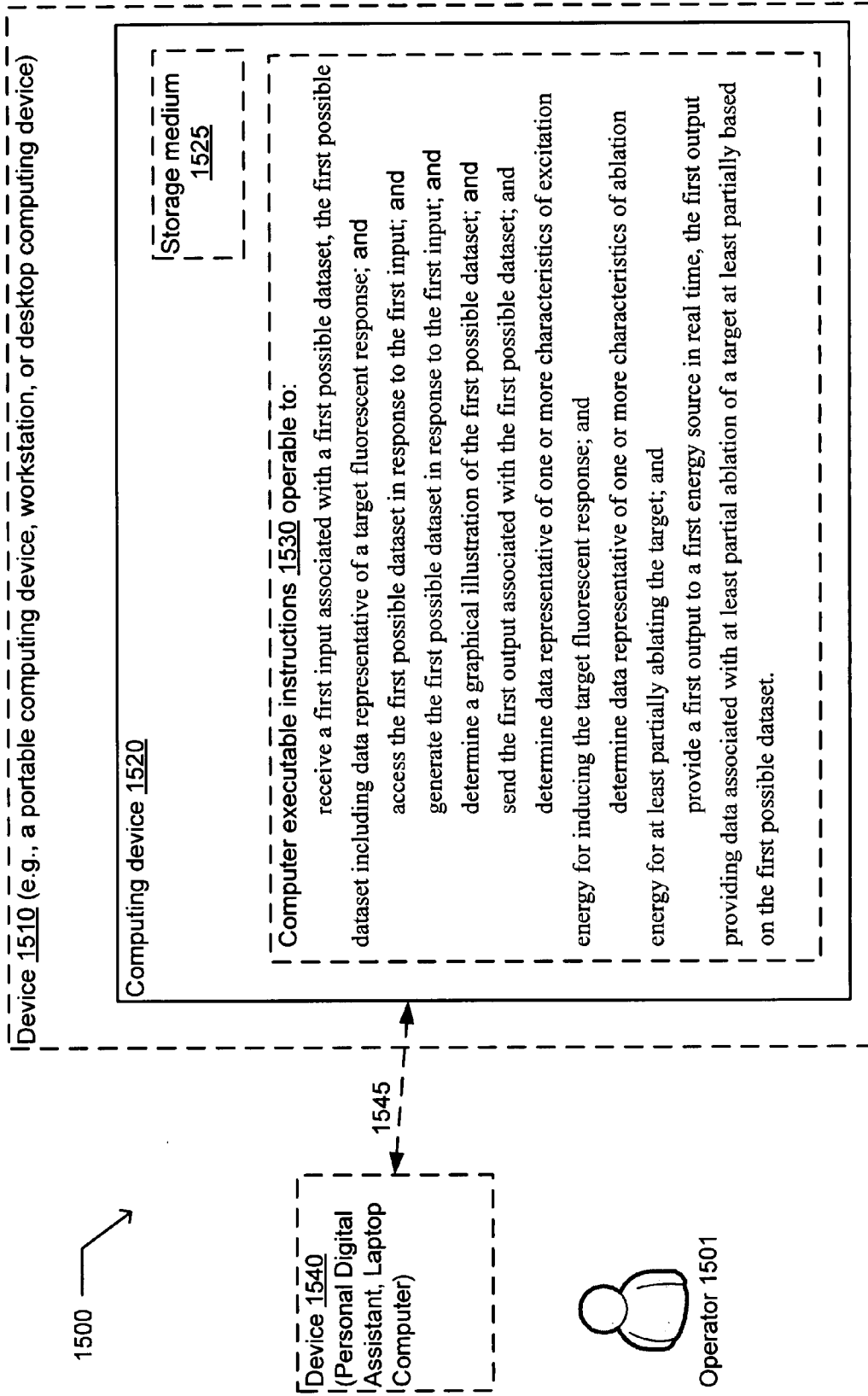

FIG. 21

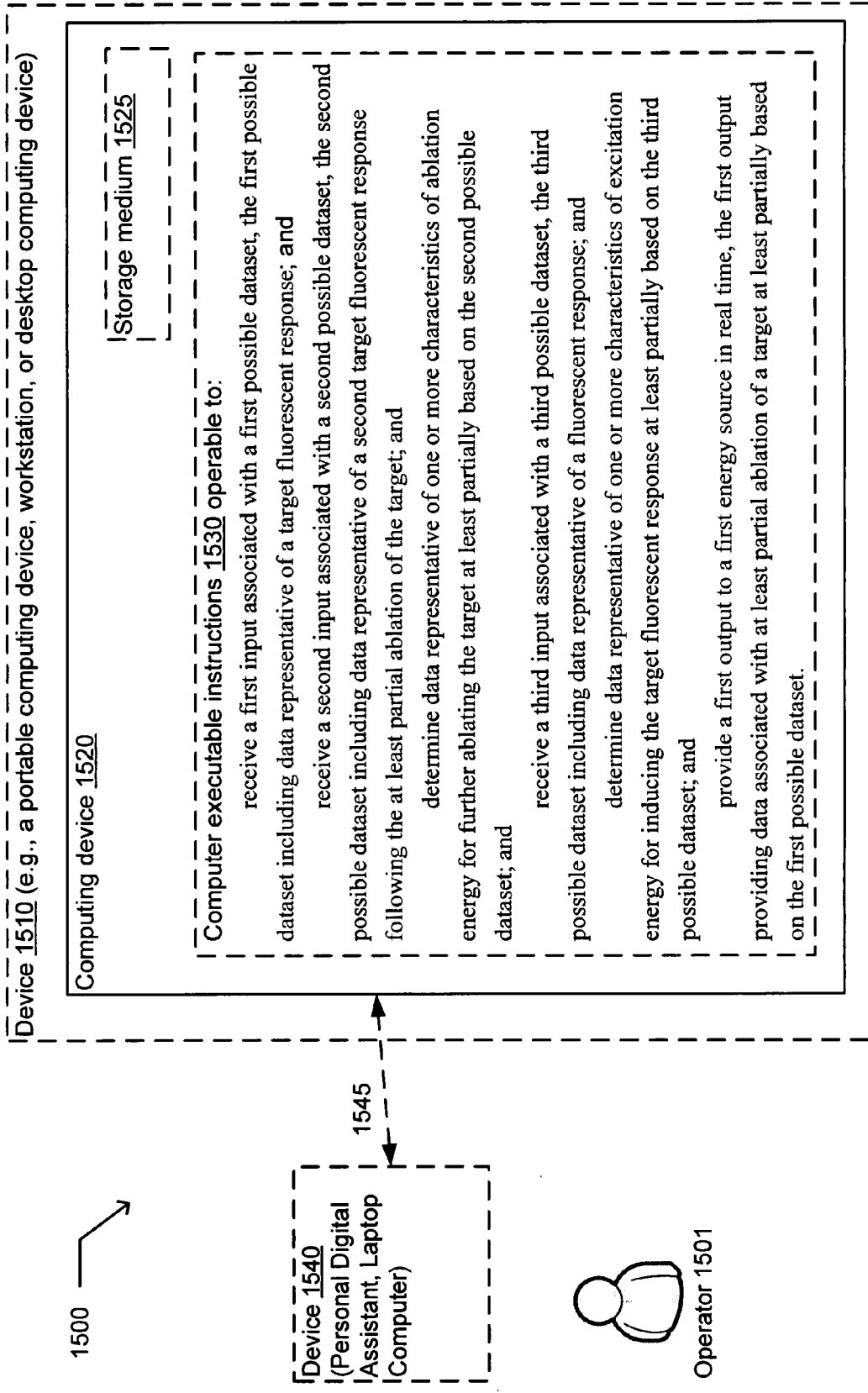

FIG. 22

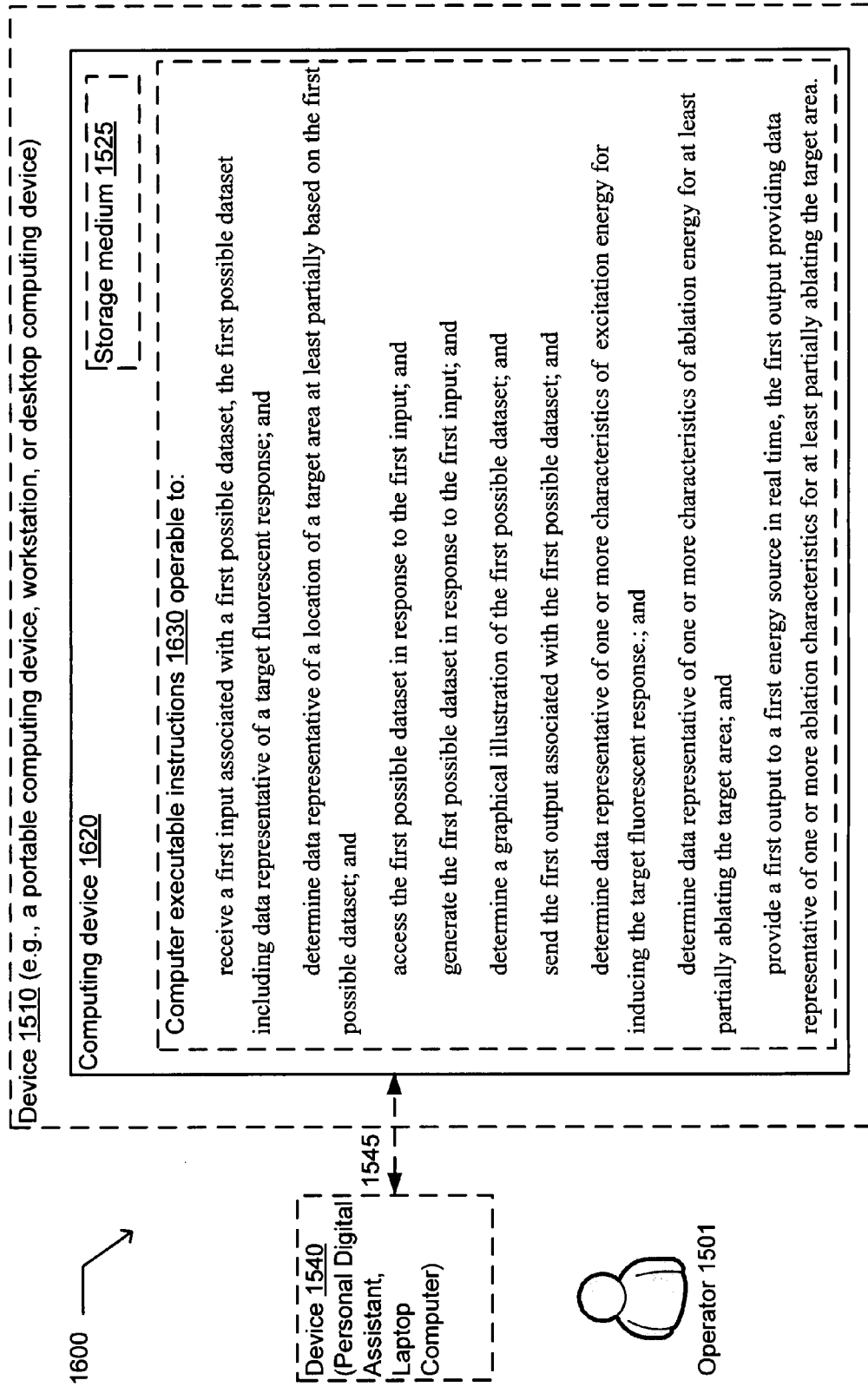

FIG. 23

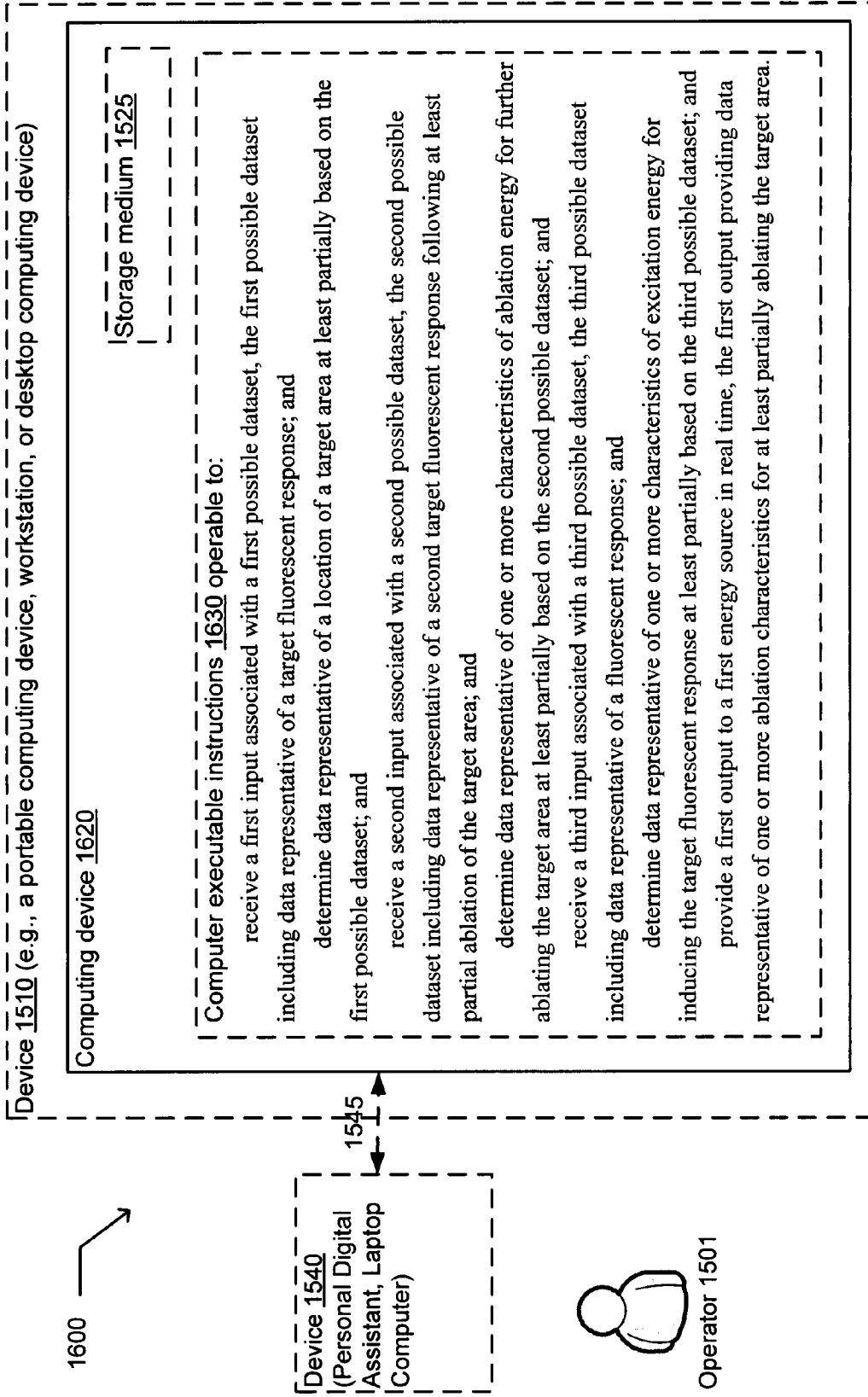

FIG. 24

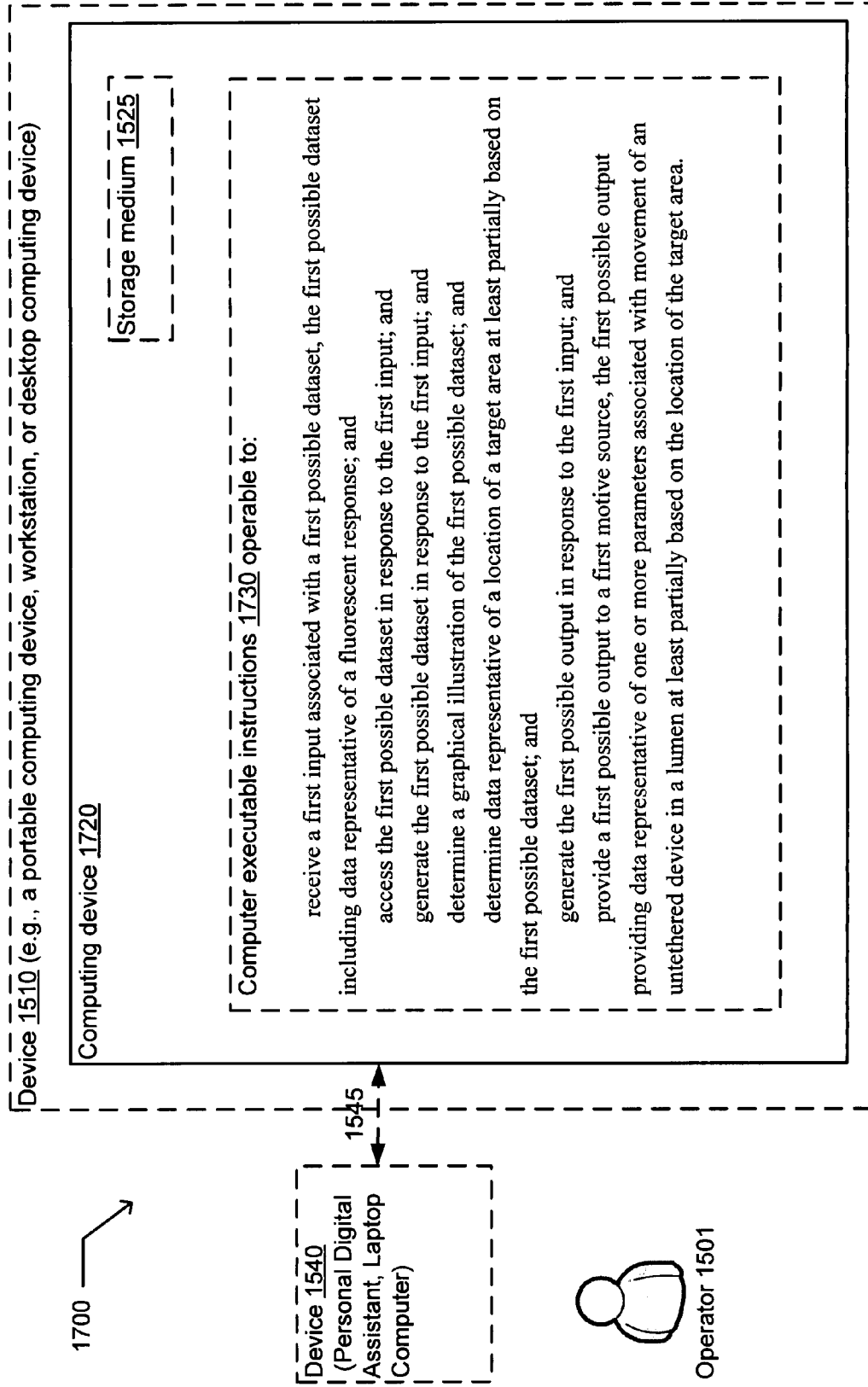

FIG. 25

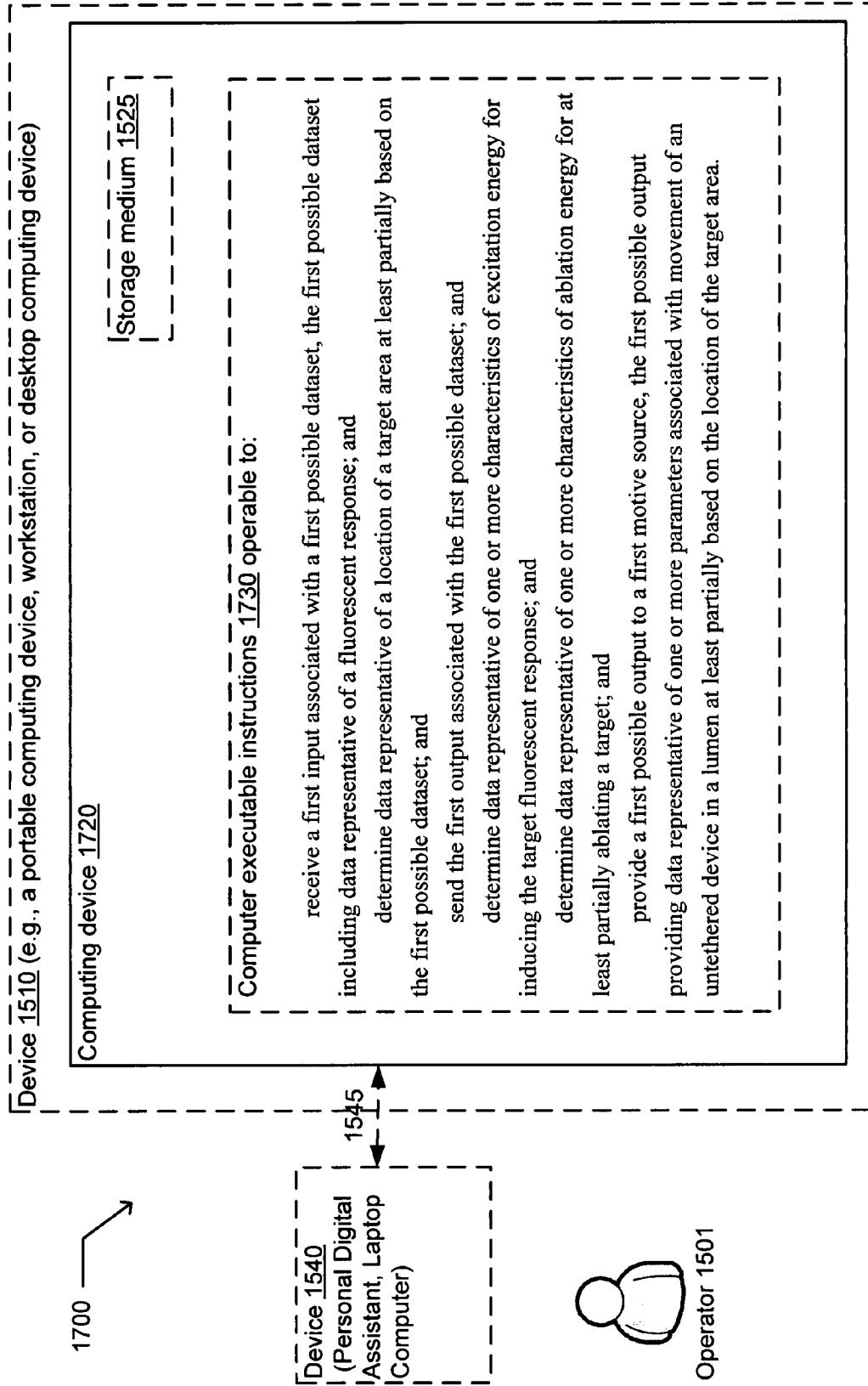

FIG. 26

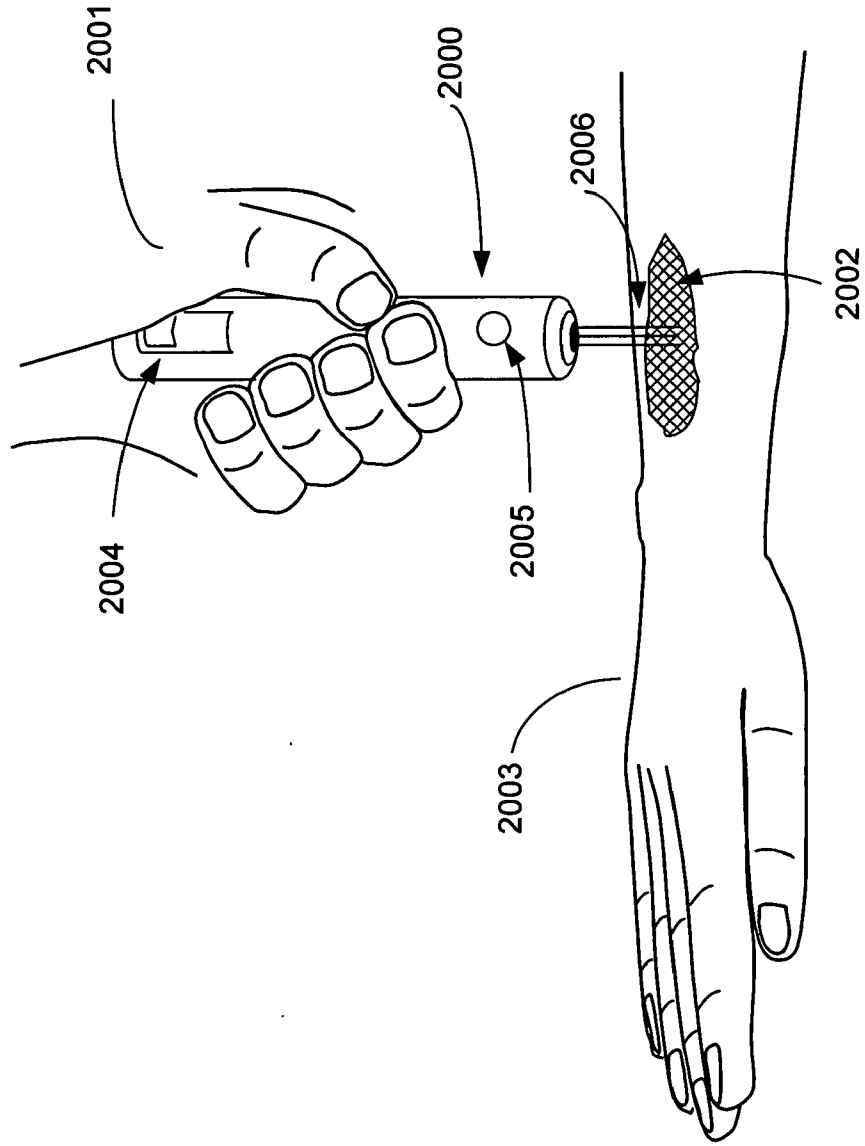

FIG. 27

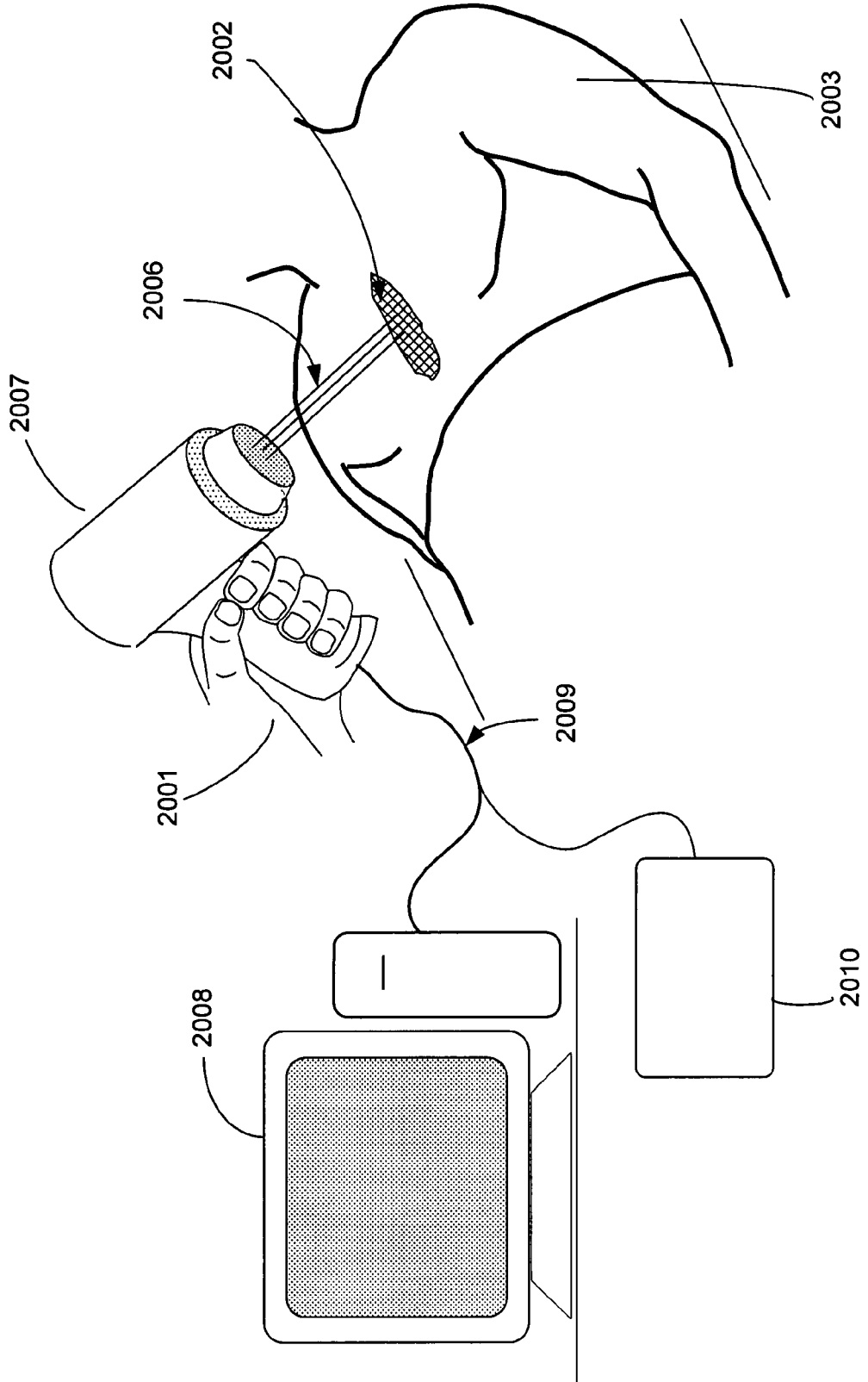

FIG. 28

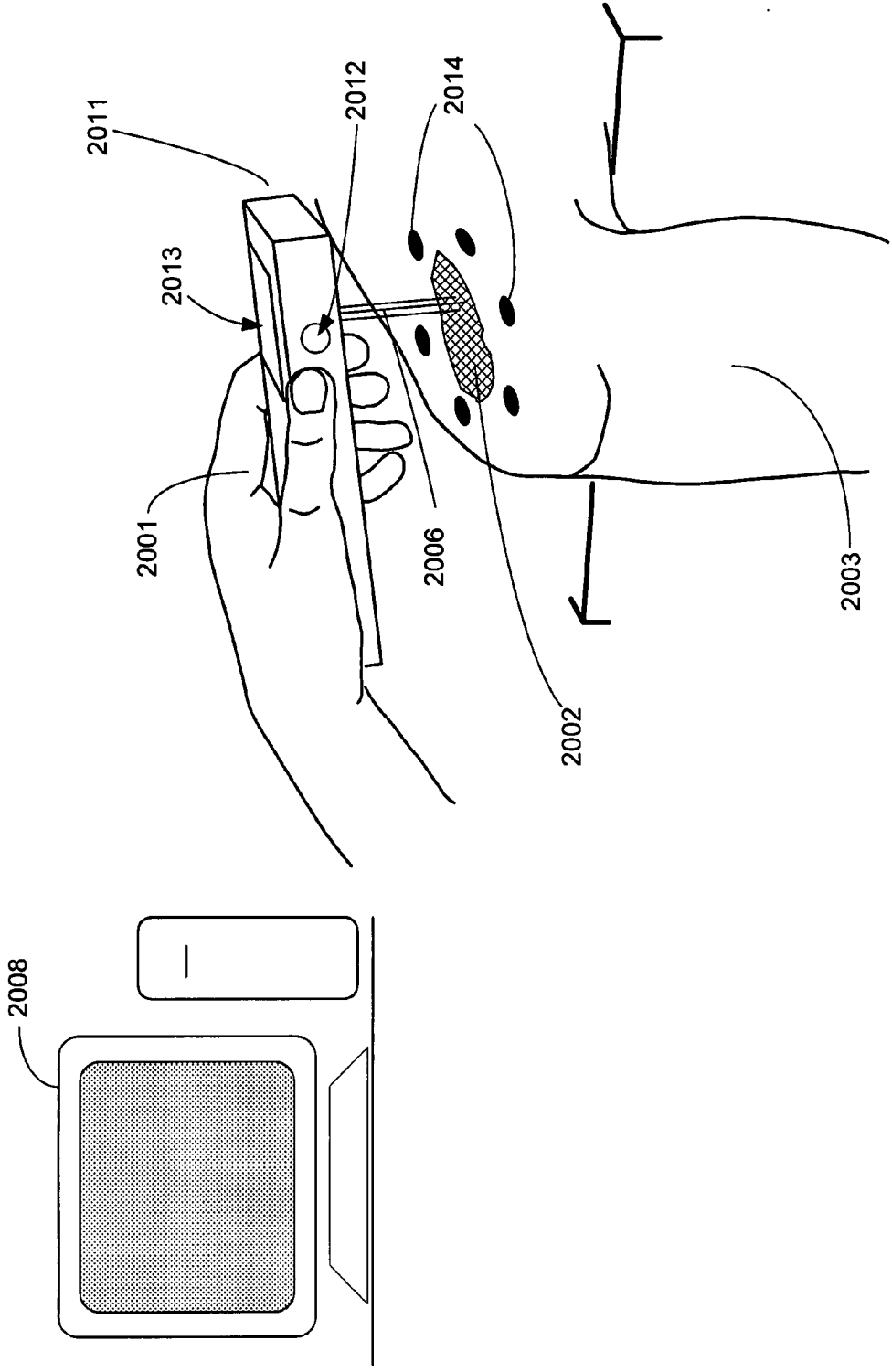

FIG. 29

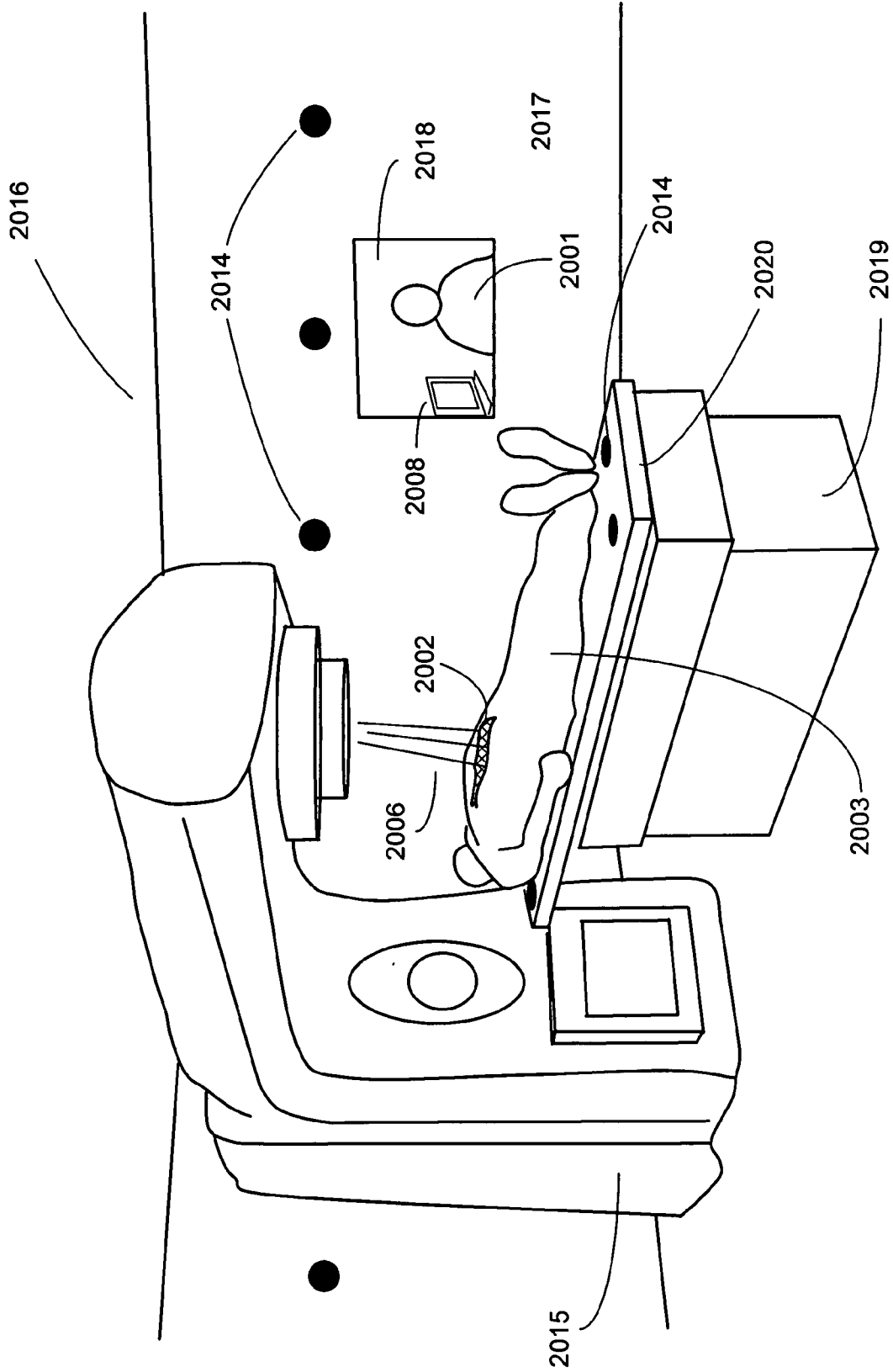

FIG. 30

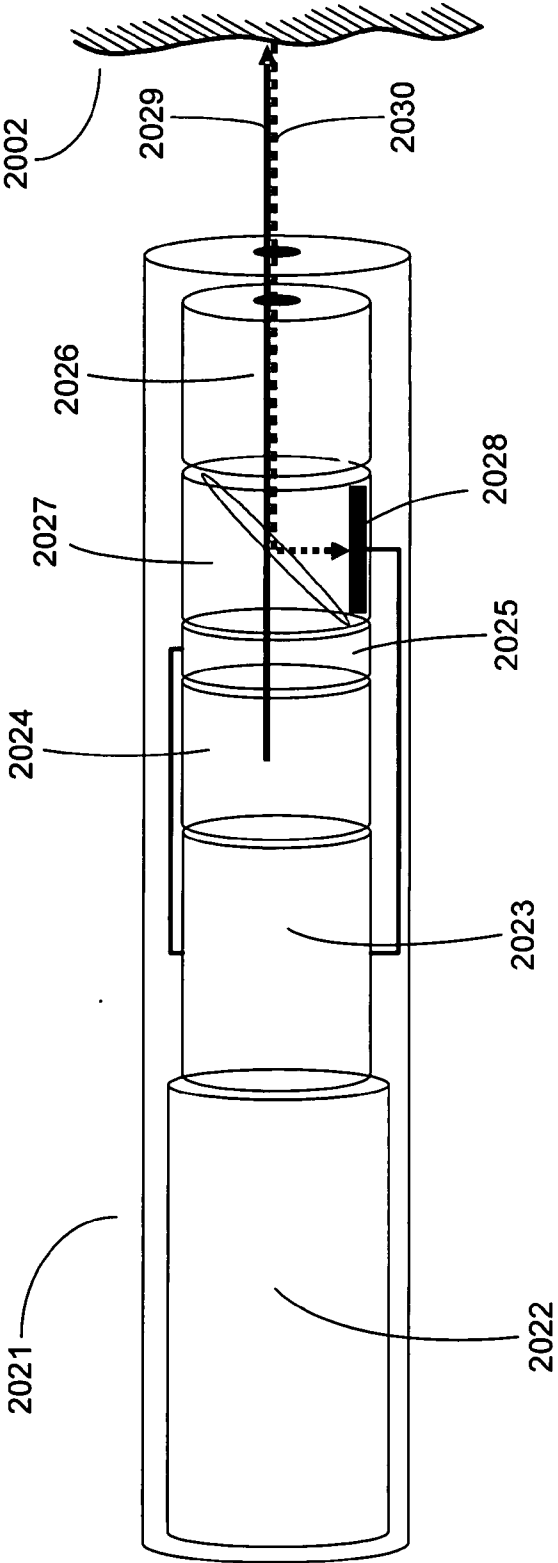

FIG. 31

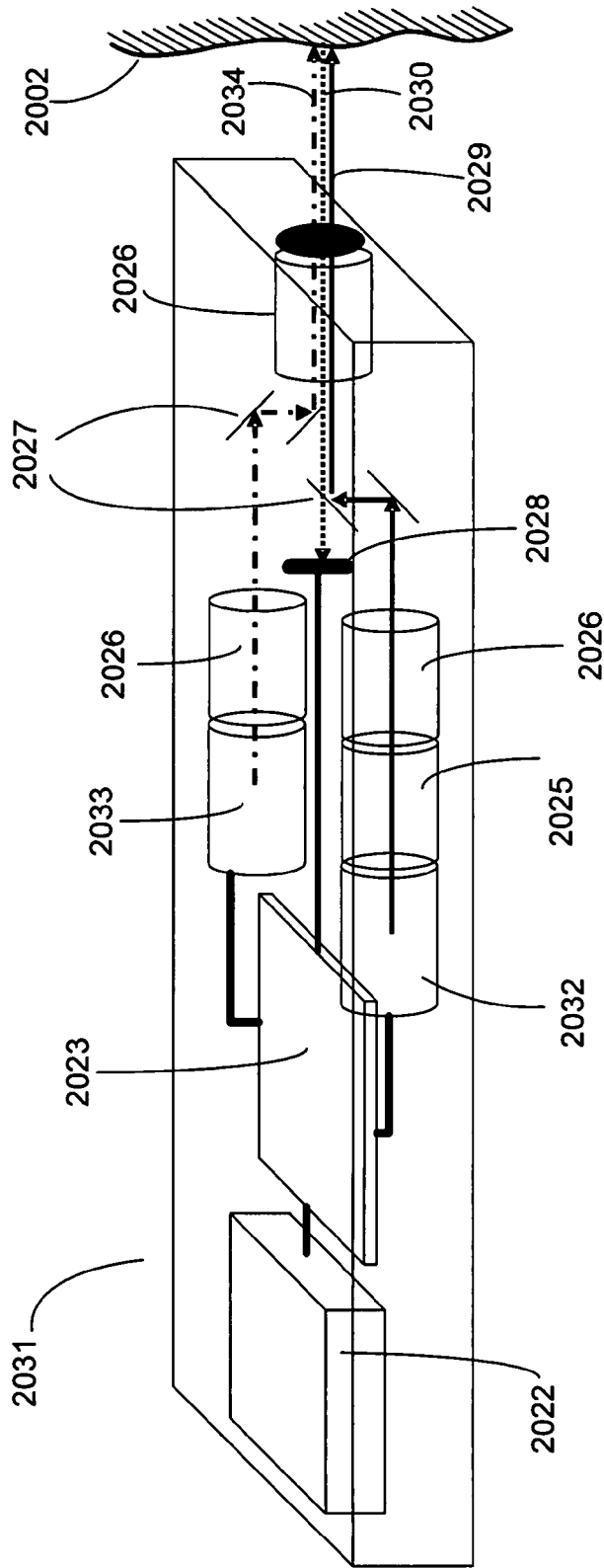

FIG. 32

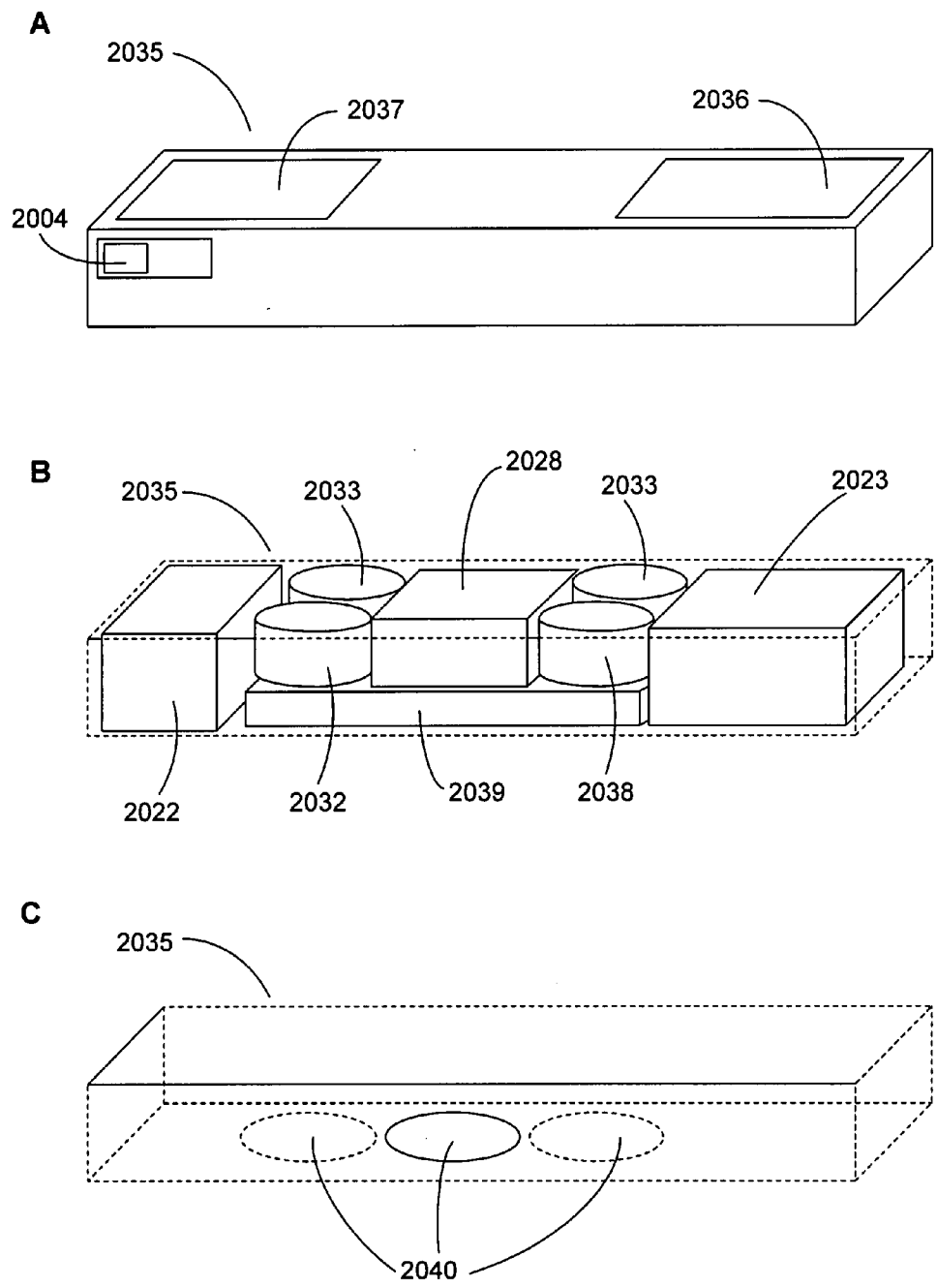

FIG. 33

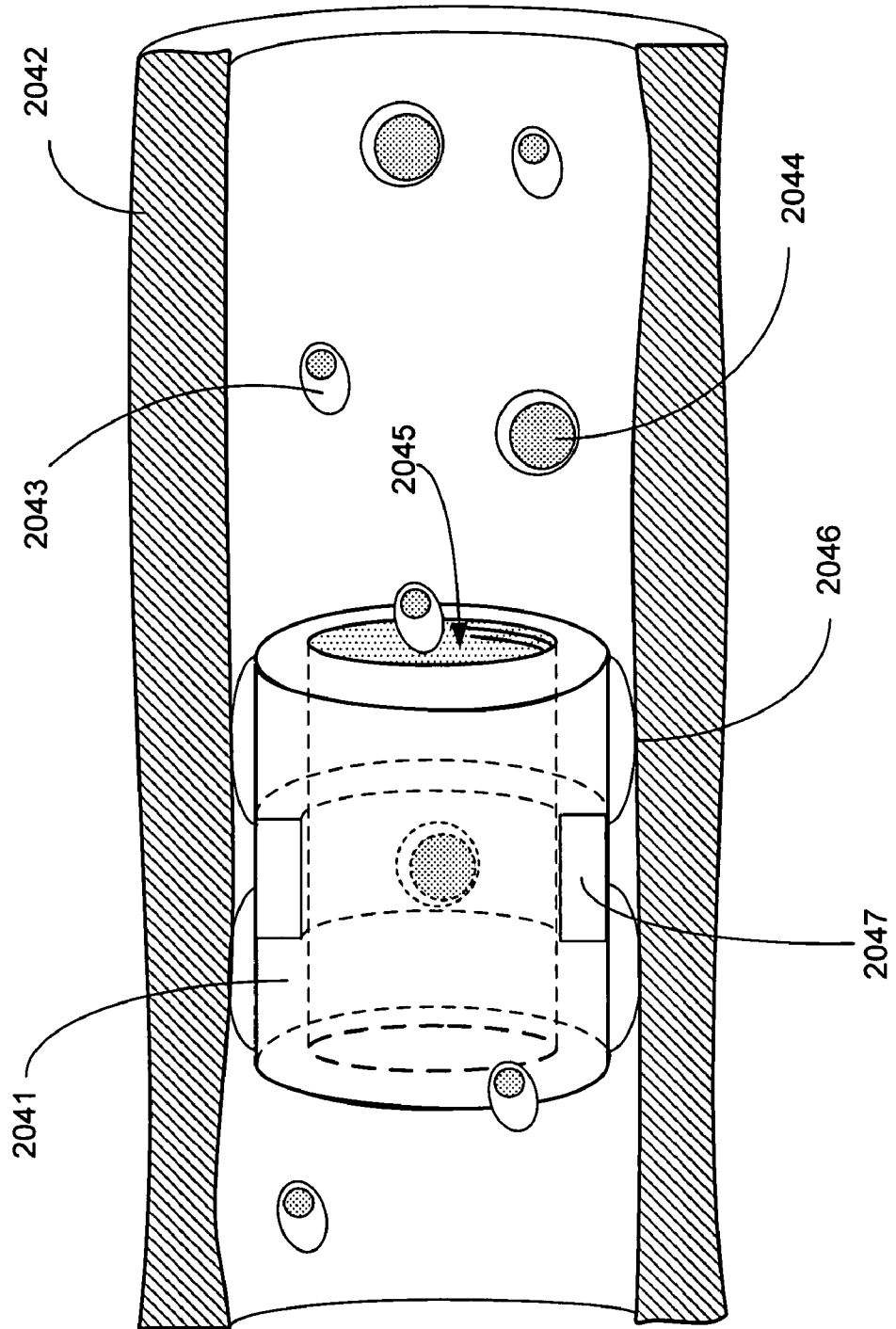

FIG. 34

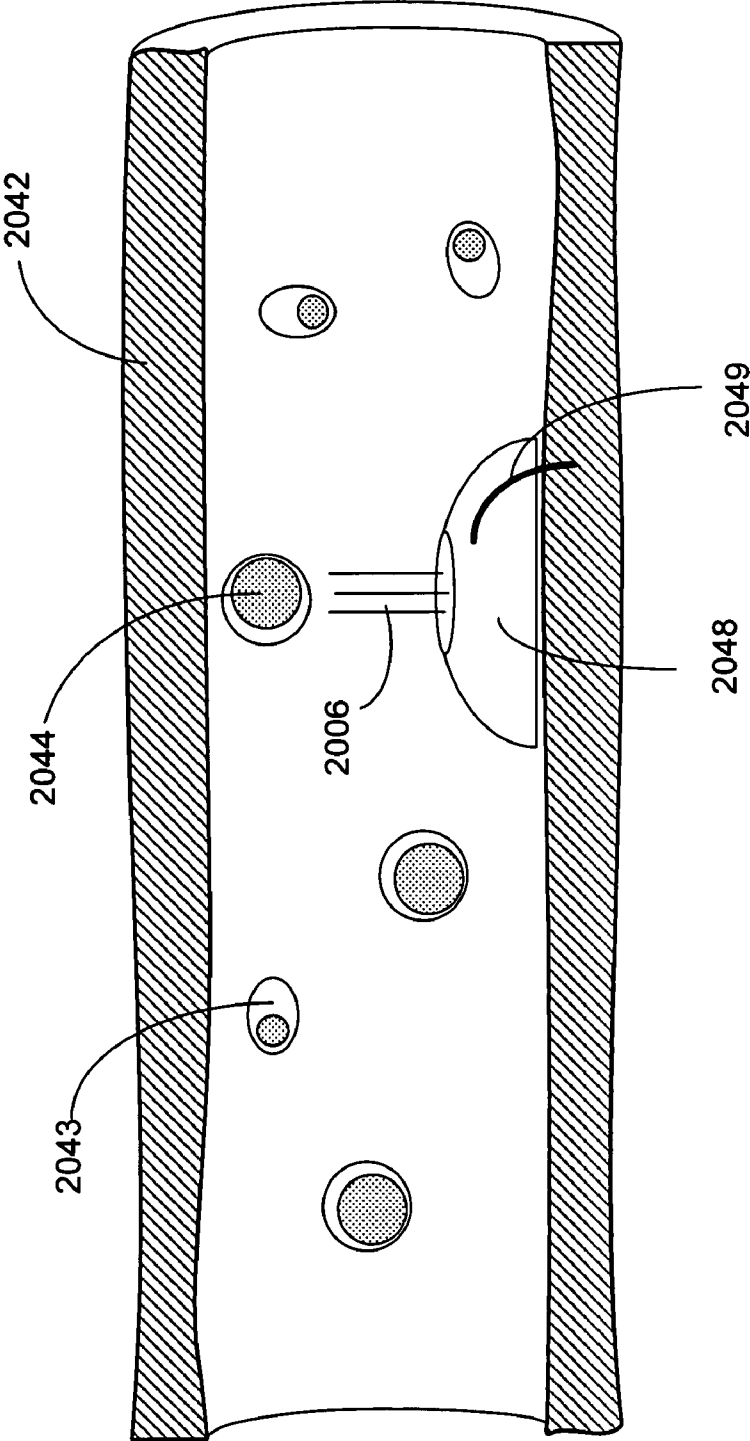

FIG. 35

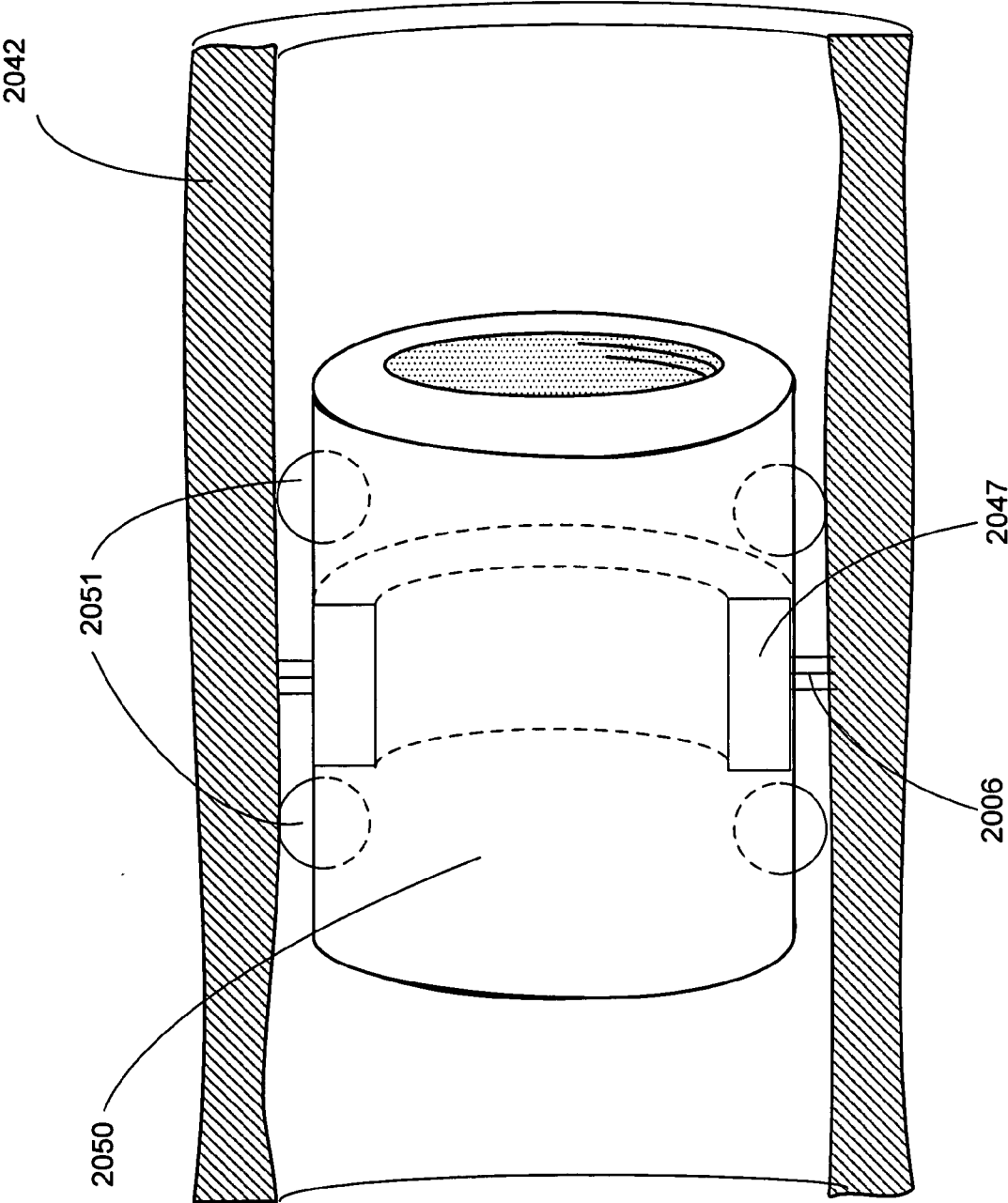

FIG. 36

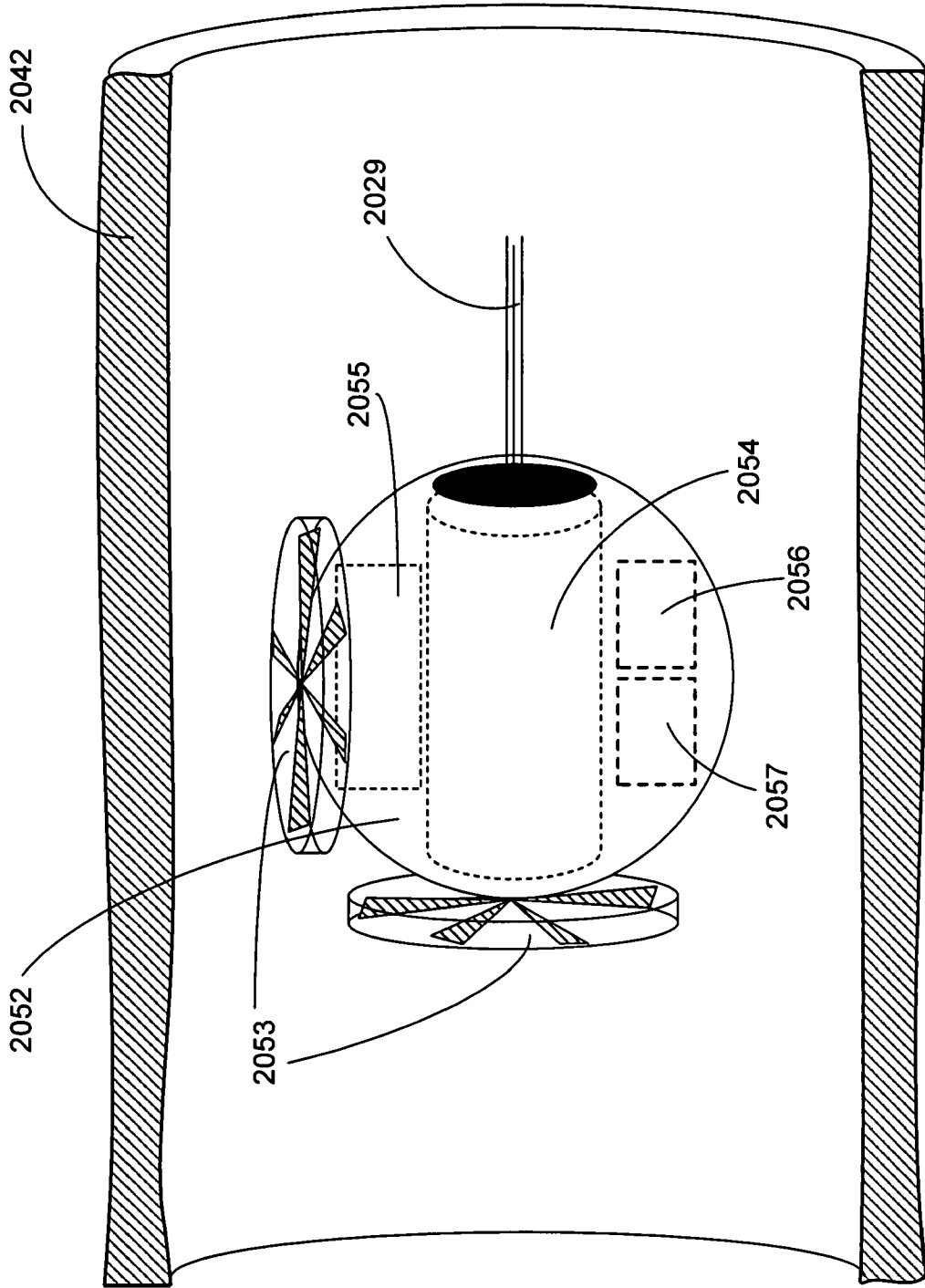

FIG. 37

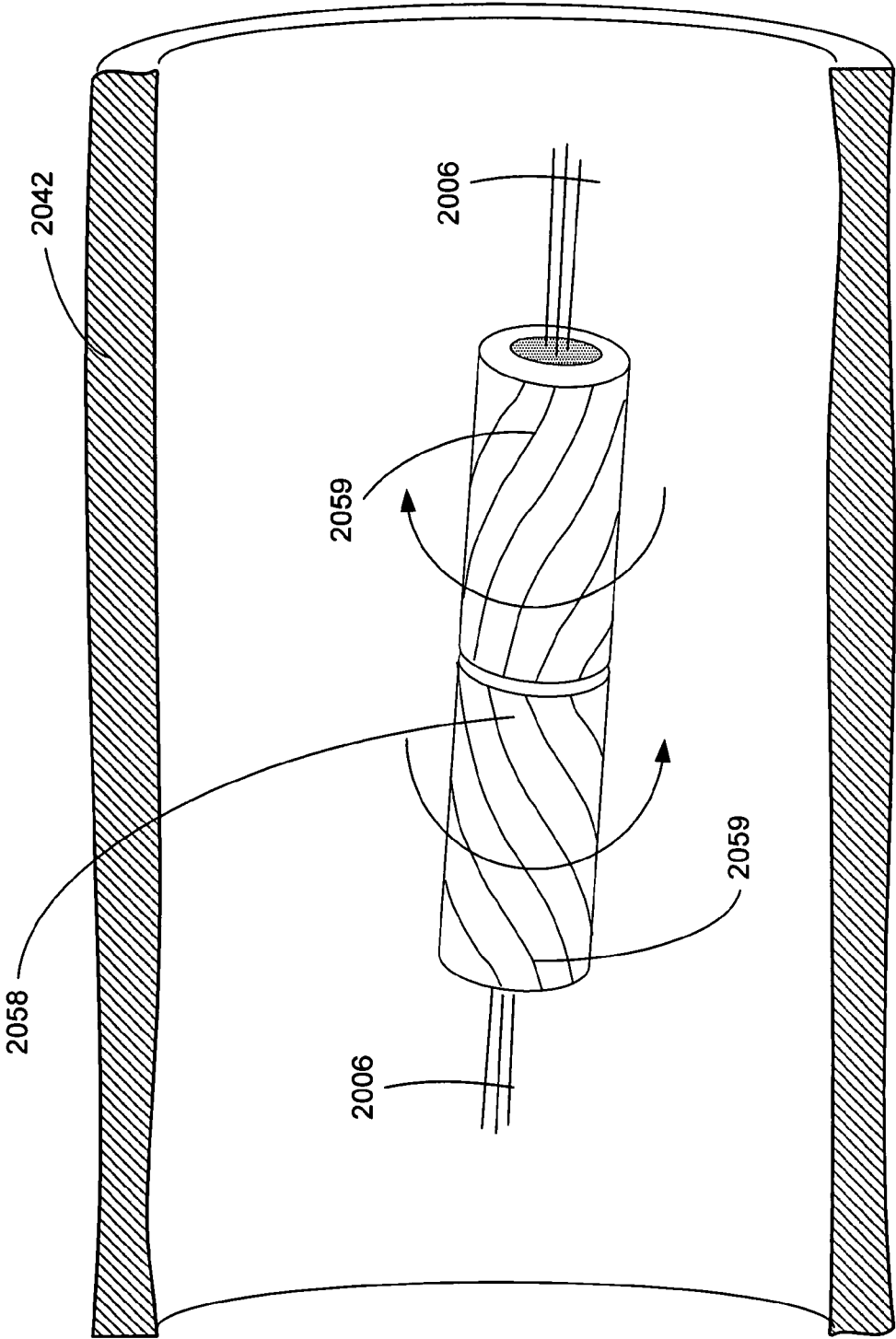

FIG. 38

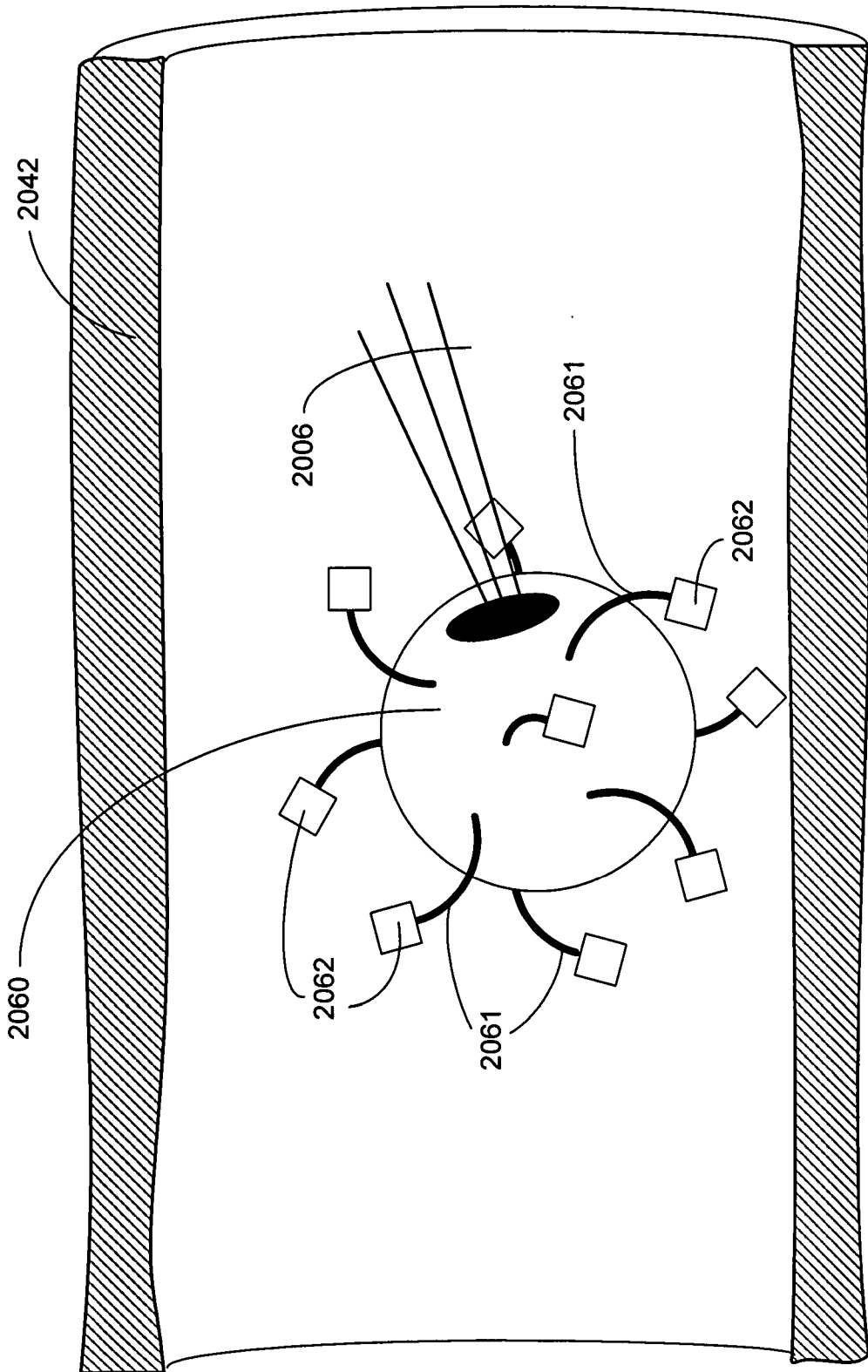

FIG. 39

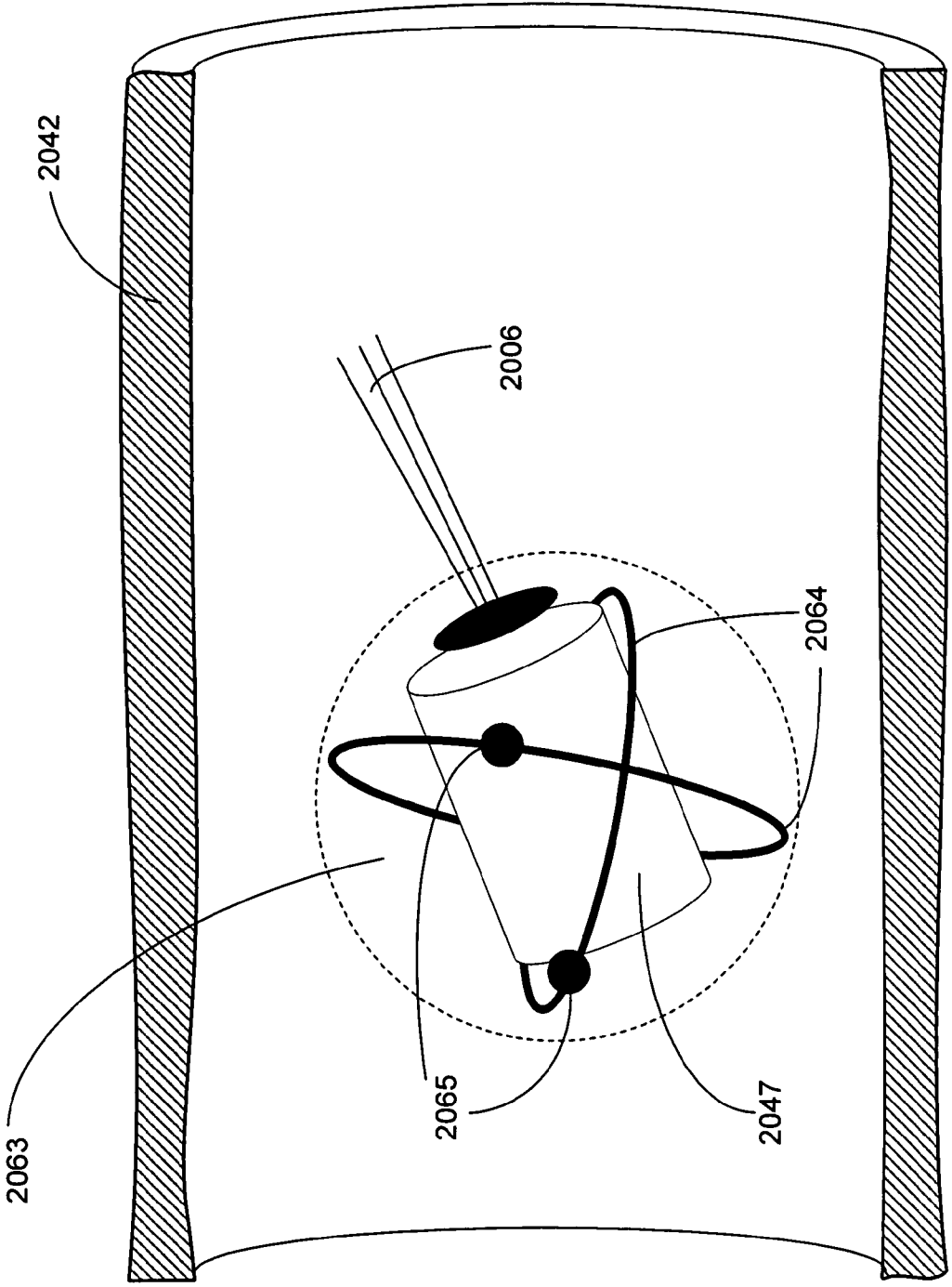
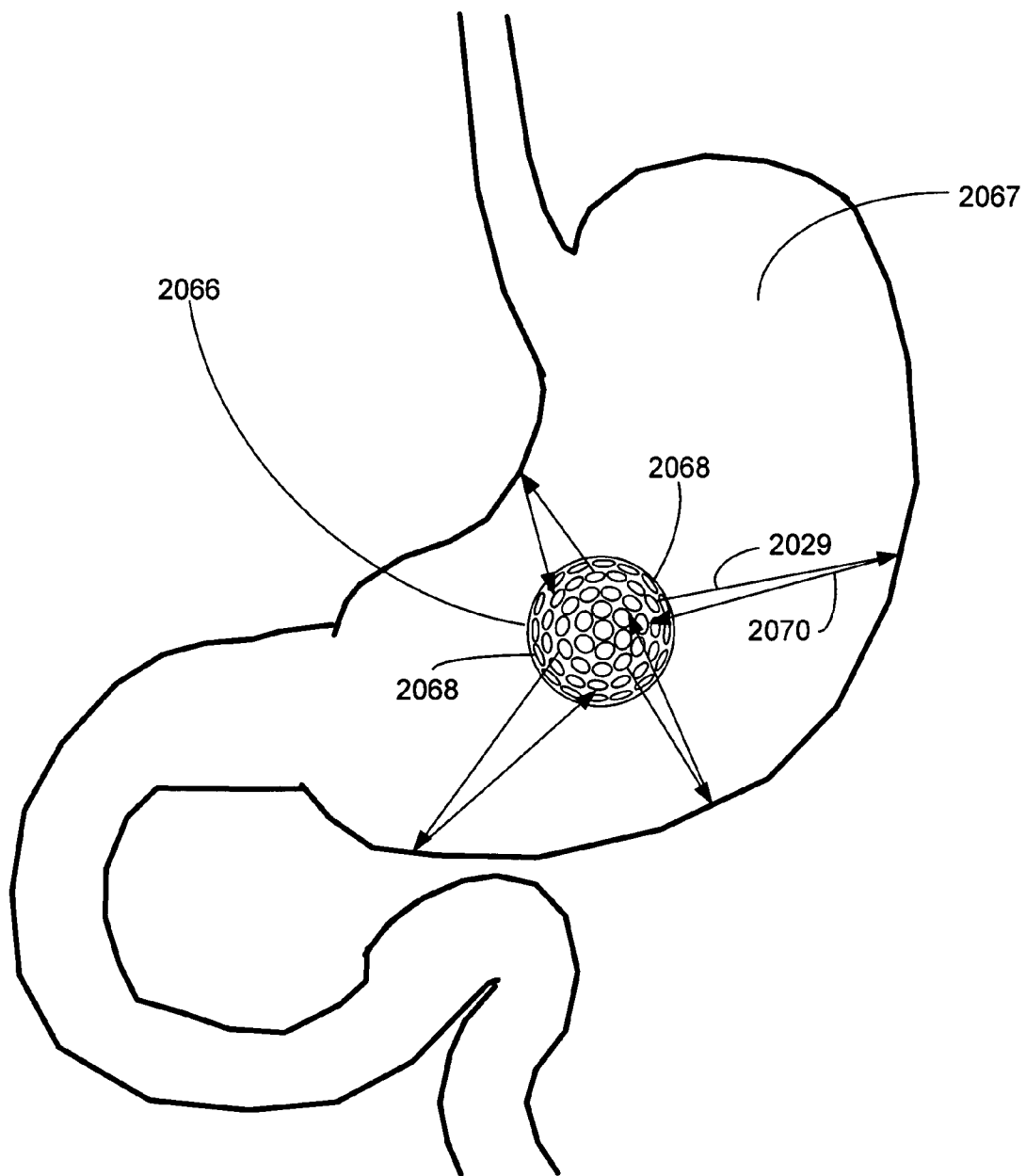

FIG. 40



AUTOFLUORESCENT IMAGING AND TARGET ABLATION

CROSS-REFERENCE TO RELATED APPLICATIONS

[0001] The present application is related to and claims the benefit of the earliest available effective filing date(s) from the following listed application(s) (the "Related Applications") (e.g., claims earliest available priority dates for other than provisional patent applications or claims benefits under 35 USC § 119(e) for provisional patent applications, for any and all parent, grandparent, great-grandparent, etc. applications of the Related Application(s)).

RELATED APPLICATIONS

[0002] For purposes of the USPTO extra-statutory requirements, the present application constitutes a continuation-in-part of U.S. patent application Ser. No. 11/403,230, entitled LUMENALLY-ACTIVE DEVICE, naming Bran Ferren; W. Daniel Hillis; Roderick A. Hyde; Muriel Y Ishikawa; Edward K. Y. Jung; Nathan P. Myhrvold; Elizabeth A. Sweeney; Clarence T. Tegreene; Richa Wilson; Lowell L. Wood, Jr. and Victoria Y. H. Wood as inventors, filed 12 Apr. 2006, which is currently co-pending, or is an application of which a currently co-pending application is entitled to the benefit of the filing date.

[0003] For purposes of the USPTO extra-statutory requirements, the present application constitutes a continuation-in-part of U.S. patent application Ser. No. 11/645,357, entitled LUMENALLY-TRAVELING DEVICE, naming Bran Ferren; W. Daniel Hillis; Roderick A. Hyde; Muriel Y Ishikawa; Edward K. Y. Jung; Eric C. Leuthardt; Nathan P. Myhrvold; Elizabeth A. Sweeney; Clarence T. Tegreene; Richa Wilson; Lowell L. Wood, Jr. and Victoria Y. H. Wood as inventors, filed 21 Dec. 2006, which is currently co-pending, or is an application of which a currently co-pending application is entitled to the benefit of the filing date.

[0004] For purposes of the USPTO extra-statutory requirements, the present application constitutes a continuation-in-part of United States patent application No. [To Be Assigned], entitled AUTOFLUORESCENT IMAGING AND TARGET ABLATION, naming Edward S. Boyden; Roderick A. Hyde; Muriel Y. Ishikawa; Eric C. Leuthardt; Nathan P. Myhrvold; Dennis J. Rivet; and Lowell L. Wood, Jr. as inventors, filed 24 Aug. 2007, which is currently co-pending, or is an application of which a currently co-pending application is entitled to the benefit of the filing date. [Attorney Docket No. 0606-002-012A-000000]

[0005] For purposes of the USPTO extra-statutory requirements, the present application constitutes a continuation-in-part of United States patent application No. [To Be Assigned], entitled SYSTEMS FOR AUTOFLUORESCENT IMAGING AND TARGET ABLATION, naming Edward S. Boyden; Roderick A. Hyde; Muriel Y. Ishikawa; Eric C. Leuthardt; Nathan P. Myhrvold; Dennis J. Rivet; and Lowell L. Wood, Jr. as inventors, filed 24 Aug. 2007, which is currently co-pending, or is an application of which a currently

co-pending application is entitled to the benefit of the filing date. [Attorney Docket No. 0606-002-012B-000000]

[0006] For purposes of the USPTO extra-statutory requirements, the present application constitutes a continuation-in-part of United States patent application No. [To Be Assigned], entitled SYSTEMS FOR AUTOFLUORESCENT IMAGING AND TARGET ABLATION, naming Edward S. Boyden; Roderick A. Hyde; Muriel Y. Ishikawa; Eric C. Leuthardt; Nathan P. Myhrvold; Dennis J. Rivet; and Lowell L. Wood, Jr. as inventors, filed 24 Aug. 2007, which is currently co-pending, or is an application of which a currently co-pending application is entitled to the benefit of the filing date. [Attorney Docket No. 0606-002-012C-000000]

[0007] For purposes of the USPTO extra-statutory requirements, the present application constitutes a continuation-in-part of United States patent application No. [To Be Assigned], entitled AUTOFLUORESCENT IMAGING AND TARGET ABLATION, naming Edward S. Boyden; Roderick A. Hyde; Muriel Y. Ishikawa; Eric C. Leuthardt; Nathan P. Myhrvold; Dennis J. Rivet; and Lowell L. Wood, Jr. as inventors, filed 24 Aug. 2007, which is currently co-pending, or is an application of which a currently co-pending application is entitled to the benefit of the filing date. [Attorney Docket No. 0606-002-012D-000000]

[0008] For purposes of the USPTO extra-statutory requirements, the present application constitutes a continuation-in-part of United States patent application No. [To Be Assigned], entitled SYSTEM FOR AUTOFLUORESCENT IMAGING AND TARGET ABLATION, naming Edward S. Boyden; Roderick A. Hyde; Muriel Y. Ishikawa; Eric C. Leuthardt; Nathan P. Myhrvold; Dennis J. Rivet; and Lowell L. Wood, Jr. as inventors, filed 24 Aug. 2007, which is currently co-pending, or is an application of which a currently co-pending application is entitled to the benefit of the filing date. [Attorney Docket No. 0606-002-012E-000000]

[0009] For purposes of the USPTO extra-statutory requirements, the present application constitutes a continuation-in-part of United States patent application No. [To Be Assigned], entitled AUTOFLUORESCENT IMAGING AND TARGET ABLATION, naming Edward S. Boyden; Roderick A. Hyde; Muriel Y. Ishikawa; Eric C. Leuthardt; Nathan P. Myhrvold; Dennis J. Rivet; and Lowell L. Wood, Jr. as inventors, filed 24 Aug. 2007, which is currently co-pending, or is an application of which a currently co-pending application is entitled to the benefit of the filing date. [Attorney Docket No. 0606-002-012F-000000]

[0010] For purposes of the USPTO extra-statutory requirements, the present application constitutes a continuation-in-part of United States patent application No. [To Be Assigned], entitled AUTOFLUORESCENT IMAGING AND TARGET ABLATION, naming Edward S. Boyden; Roderick A. Hyde; Muriel Y. Ishikawa; Eric C. Leuthardt; Nathan P. Myhrvold; Dennis J. Rivet; and Lowell L. Wood, Jr. as inventors, filed 24 Aug. 2007, which is currently co-pending, or is

an application of which a currently co-pending application is entitled to the benefit of the filing date. [Attorney Docket No. 0606-002-012G-000000]

[0011] The United States Patent Office (USPTO) has published a notice to the effect that the USPTO's computer programs require that patent applicants reference both a serial number and indicate whether an application is a continuation or continuation-in-part. Stephen G. Kunin, Benefit of Prior-Filed Application, USPTO Official Gazette Mar. 18, 2003, available at <http://www.uspto.gov/web/offices/com/sol/og/2003/week11/patbene.htm>. The present Applicant Entity (hereinafter "Applicant") has provided above a specific reference to the application(s) from which priority is being claimed as recited by statute. Applicant understands that the statute is unambiguous in its specific reference language and does not require either a serial number or any characterization, such as "continuation" or "continuation-in-part," for claiming priority to U.S. patent applications. Notwithstanding the foregoing, Applicant understands that the USPTO's computer programs have certain data entry requirements, and hence Applicant is designating the present application as a continuation-in-part of its parent applications as set forth above, but expressly points out that such designations are not to be construed in any way as any type of commentary and/or admission as to whether or not the present application contains any new matter in addition to the matter of its parent application(s).

[0012] All subject matter of the Related Applications and of any and all parent, grandparent, great-grandparent, etc. applications of the Related Applications is incorporated herein by reference to the extent such subject matter is not inconsistent herewith.

SUMMARY

[0013] The present application relates, in general, to apparatus and devices for fluorescent-based imaging and ablation of medical targets, as well as related methods and systems implementations. Such apparatus, devices, methods and/or systems are useful for ablating target cells and/or tissues as well as treatment, prevention, and/or amelioration of a variety of diseases and disorders. Apparatus and/or devices may be configured to be used externally or internally, to be handheld, intra-luminal, or ingestible, and/or to be tethered or untethered. Various methods and/or systems implementations include using one or more of the apparatus or devices for ablating target cells in wounds and/or surgical lesions, intra-lumenally, or in the digestive tract. Illustrative examples include using one or more of the apparatus, devices, methods and/or systems to treat *H. pylori* infection, and/or to test and ablate cancer margins.

[0014] The foregoing summary is illustrative only and is not intended to be in any way limiting. In addition to the illustrative aspects, embodiments, and features described above, further aspects, embodiments, and features will become apparent by reference to the drawings and the following detailed description.

BRIEF DESCRIPTION OF THE FIGURES

[0015] FIG. 1 shows a schematic of an illustrative apparatus in which embodiments may be implemented.

[0016] FIG. 2 shows a schematic of illustrative embodiments of the apparatus of FIG. 1, with illustrative examples of an energy source.

[0017] FIG. 3 shows a schematic of illustrative embodiments of the apparatus of FIG. 1, with illustrative examples of a sensor.

[0018] FIGS. 4-6 show a schematic of an illustrative untethered device in which embodiments may be implemented.

[0019] FIG. 7 shows a schematic of an illustrative tethered device in which embodiments may be implemented.

[0020] FIG. 8 and FIG. 9 show an operational flow representing illustrative embodiments of operations related to providing a first output to a first energy source in real time, the first output providing data associated with at least partial ablation of a target at least partially based on the first possible dataset.

[0021] FIG. 10 and FIG. 11 show an operational flow representing illustrative embodiments of operations related to providing a first output to a first energy source in real time, the first output providing data representative of one or more ablation characteristics for at least partially ablating a target area.

[0022] FIG. 12 and FIG. 13 show an operational flow representing illustrative embodiments of operations related to providing a first possible output to a first motive source, the first possible output providing data representative of one or more parameters associated with movement of an untethered device in a lumen at least partially based on the location of the target area.

[0023] FIGS. 14-19 show a partial view of an illustrative embodiment of a computer program product that includes a computer program for executing a computer process on a computing device.

[0024] FIGS. 20-25 show an illustrative embodiment of a system in which embodiments may be implemented.

[0025] FIG. 26 shows a schematic of an example of an illustrative embodiment of a handheld device in use on an illustrative subject.

[0026] FIG. 27 shows a schematic of an example of an illustrative embodiment of a device in use on an illustrative subject.

[0027] FIG. 28 shows a schematic of an example of an illustrative embodiment of a handheld device in use on an illustrative subject.

[0028] FIG. 29 shows a schematic of an example of an illustrative embodiment of a device in use on an illustrative subject.

[0029] FIGS. 30-31 show a schematic of an example of an illustrative embodiment of a handheld device.

[0030] FIGS. 32A, 32B, and 32C show a schematic of an example of an illustrative embodiment of a handheld device.

[0031] FIG. 33 shows a schematic of an example of an illustrative embodiment of an untethered device in use on an illustrative subject.

[0032] FIGS. 34-40 show a schematic of an example of an illustrative embodiment of an untethered device in use on an illustrative subject.

DETAILED DESCRIPTION

[0033] In the following detailed description, reference is made to the accompanying drawings, which form a part hereof. In the drawings, similar symbols typically identify similar components, unless context dictates otherwise. The illustrative embodiments described in the detailed description, drawings, and claims are not meant to be limiting. Other embodiments may be utilized, and other changes may be made, without departing from the spirit or scope of the subject matter presented here.

[0034] The present application relates, in general, to apparatus, devices, systems, and methods of fluorescent imaging, optionally autofluorescent imaging, and ablation of medical targets. Those having skill in the art will appreciate that the specific systems, apparatus, devices, and methods described herein are intended as merely illustrative of their more general counterparts.

[0035] In one aspect, FIG. 1 through FIG. 7 depict one or more embodiments of one or more apparatus 100 and/or 500 and/or devices 200, 300, and/or 400 configured to detect and ablate targets at least partially based on a fluorescent response. Although one or more embodiments of one or more apparatus and/or devices may be presented separately herein, it is intended and envisioned that one or more apparatus and/or devices and/or embodiments of one or more apparatus and/or devices, in whole or in part, may be combined and/or substituted to encompass a full disclosure of the one or more apparatus and/or devices. In some embodiments, one or more apparatus and/or devices may include one or more system implementations including methods of operations, and/or include one or more computing devices and/or systems configured to perform one or more methods. As disclosed below, one or more apparatus and/or devices may be used in one or more methods of treatment and/or methods for ablating targets described herein.

[0036] FIG. 1, FIG. 2, and FIG. 3 depict illustrative embodiments of one or more apparatus 100 having a first energy source 110 alignable to a lesion and configured to provide electromagnetic energy selected to induce a fluorescent response from a target area in the lesion; a sensor 120 configured to detect the fluorescent response; control circuitry 130 coupled to the sensor 120 and responsive to identify the target area; and a second energy source 110 responsive to the control circuitry 130 and configured to emit energy selected to at least partially ablate the target area.

[0037] FIG. 4, FIG. 5, and FIG. 6 depict illustrative embodiments of one or more untethered device 200, 300, and 400, respectively.

[0038] FIG. 4 depicts illustrative embodiments of one or more untethered device 200 having an energy source 100, optionally a first electromagnetic energy source 111 configured to function in a lumen and configured to provide electromagnetic energy selected to induce an auto-fluorescent response in one or more target cells in proximity to the lumen; a sensor 120 configured to detect the auto-fluorescent response; control circuitry 130 coupled to the sensor 120 and responsive to identify a target area; optionally a second electromagnetic energy source 111 responsive to the control circuitry 130 and configured to emit energy selected to at

least partially ablate the target area, optionally a power source 140, and optionally a motive source 150.

[0039] FIG. 5 depicts illustrative embodiments of one or more devices 300 for treating or ameliorating *H. pylori* infection including an untethered ingestible mass 310 optionally shaped for non-uniform movement having an electromagnetic energy source 111 optionally configured to emit variable directional electromagnetic energy in a manner selected to induce photodynamic cell death in *H. pylori*. In some embodiments, one or more devices 300 for ablating *H. pylori* include an untethered ingestible mass 310, optionally shaped for non-uniform movement, having an electromagnetic energy source 111 optionally configured to emit variable directional electromagnetic energy in a manner selected to induce photodynamic cell death in *H. pylori*.

[0040] FIG. 6 depicts illustrative embodiments of one or more devices 400 including an untethered ingestible mass 310 optionally configured to rotate, optionally shaped for non-uniform movement, wherein the untethered ingestible mass 310 includes: an energy source 110, optionally a first electromagnetic energy source 111 configured to provide electromagnetic energy selected to stimulate an auto-fluorescent response in one or more target cells in a digestive tract; a sensor 120 configured to detect the auto-fluorescent response; control circuitry 130 coupled to the sensor 120 and responsive to identify a target area; optionally a second electromagnetic energy source 111 responsive to the control circuitry 130 and configured to emit energy selected to at least partially ablate the target area, optionally a power source 140, and optionally a motive source 150.

[0041] FIG. 7 depicts illustrative embodiments of one or more tethered 510 apparatus 500 including a first energy source 110 configured to provide electromagnetic energy selected to stimulate an auto-fluorescent response in one or more target cells in an internal location; a sensor 120 configured to detect the auto-fluorescent response; control circuitry 130 coupled to the sensor 120 and responsive to identify a target area in real time; and optionally a second energy source 110 responsive to the control circuitry 130 and configured to emit energy selected to at least partially ablate the target area.

[0042] Embodiments of one or more apparatus 100 and/or 500 and/or devices 200, 300, and/or 400 may be configured for use in one or more lesions, lumens, and/or internal locations of an organism. In illustrative embodiments, one or more apparatus 100, in part or in whole, is optionally a handheld device configured for detecting and ablating microbial and/or pathological contamination or cancer cells, for example, in lesions, optionally wounds or surgical incisions. In illustrative embodiments, one or more devices 200, in part or in whole, is an intra-lumenally sized device (e.g. small enough to be placed in a blood vessel while not obstructing the flow) configured for detecting and ablating microbial and/or pathogenic infections or cancer cells/metastases, for example, in the blood stream. In illustrative embodiments, one or more devices 300 and/or 400, in whole or in part, is an ingestibly-sized device (e.g. the size of a large vitamin pill) configured for detecting and ablating microbial and/or pathogenic infections or cancer cells, for example, in the digestive tract. In illustrative embodiments, one or more apparatus 500, in whole or in part, is part of or attached to a device, optionally handheld (e.g. an endoscope

or fiber optic cable) and configured for detecting and ablating microbial and/or pathogenic infections or cancer cells, for example, in internal locations.

[0043] Embodiments of one or more apparatus **100** and/or **500** and/or devices **200**, **300**, and/or **400** may be configured as a self-contained unit that includes all functionalities necessary for operation of the device and/or apparatus, or configured as one or more subparts in one or more locations separate from one another, wherein one or more of the subparts includes one or more essential and/or non-essential functionalities. In illustrative examples, one subpart may be placed within a lumen of, for example, a blood vessel, and another subpart placed, for example, sub-cutaneously or within a larger or more accessible lumen. In illustrative embodiments, a remote portion may provide for monitoring of the lumen-based device or data collection or analysis. The remote portion may be at a separate location within the body of the subject, or outside the body of the subject. Data and/or power signals may be transmitted between the one or more subparts using electromagnetic signals, for example, or electrical or optical links. Methods of distributing functionalities of a system between hardware, firmware, and software at located at two or more sites are well known to those of skill in the art.

[0044] Embodiments of one or more apparatus **100** and/or **500** may be configured as a handheld unit, optionally self-contained and/or with one or more subparts in one or more other locations. In illustrative embodiments, a handheld unit includes one or more sources of energy **110**, and at least one monitor to provide viewing of the lesion and targeting electromagnetic energy **118**. In illustrative embodiments, a handheld unit includes control circuitry and at least one monitor for viewing lesion targeting information, as well as being connected to an energy source **110** and optionally one or more power sources **140** through one or more conduits. In illustrative embodiments, a handheld unit is wirelessly connected to control circuitry and to a monitor providing targeting information to an operator. In illustrative embodiments, apparatus **100** is a mounted, non-handheld, unit.

[0045] Embodiments of one or more apparatus **100** and/or **500** and/or devices **200**, **300**, and/or **400** may be described as having one or more subparts including, but not limited to, one or more energy sources **110**, one or more sensors **120**, one or more control circuitry **130**, one or more power sources **140**, and/or one or more motive sources **150**. In some embodiments, one or more subpart may be a physically distinct unit. In some embodiments, one or more subpart is combined with one or more other subpart to form a single unit with no physically discernible separation. Some embodiments include a first, second, third, fourth, fifth, etc. energy source **110**, sensor **120**, control circuitry **130**, power source **140**, and/or motive source **150**. One or more of the one, two three, four, five, etc. components may be the same component and/or physical entity, or one or more components may be a separate physical entity. For example, there may be two lasers in a device, or there may be one laser able to provide both excitation and ablation energy. For example, there may be two sensors in a device, or there may be one sensor able to detect a variety of energy wavelenths.

[0046] As used herein, the term “lesion” may include wounds, incisions, and/or surgical margins. In some embodi-

ments, the term “lesion” may include, but is not limited to, cells and/or tissues, optionally including cells and/or tissues of the skin and/or retina. Wounds may include, but are not limited to, scrapes, abrasions, cuts, tears, breaks, punctures, gashes, slices, and/or any injury resulting in bleeding and/or skin trauma sufficient for foreign organisms to penetrate. Incisions may include those made by a medical professional, such as but not limited to, physicians, nurses, mid-wives, and/or nurse practitioners, dental professionals, such as but not limited to, dentists, orthodontists, dental hygienists, and veterinary professionals, including but not limited to, veterinarians during treatment optionally including surgery. As used herein, the term “surgical margins” may include the edges of incisions, for example, cancer margins.

[0047] As used herein, the term “lumen” may include, but is not limited to, part or all of a nostril or nasal cavity, the respiratory tract, the cardiovascular system (e.g., a blood vessel, including for example, arteries, veins, and capillaries), the lymphatic system, the biliary tract, the urogenital tract (e.g. a ureter), the oral cavity, the digestive tract, the tear ducts, a glandular system, a male or female reproductive tract (e.g. fallopian tubes, uterus, the epididymis, vas deferens, ductal deferens, efferent duct, ampulla, seminal duct, ejaculatory duct, and/or urethra), the cerebral-spinal fluid space (e.g. the cerebral ventricles, the subarachnoid space, and/or the spinal canal), the thoracic cavity, the abdominal cavity, and other fluid-containing structures of an organism. Other lumens may be found in the auditory or visual system, or in interconnections thereof, e.g., the Eustachian tubes.

[0048] Also included within the scope of the term “lumen” are man-made lumens within the body, including vascular catheters, spinal fluid shunts, vascular grafts, bowel re-anastomoses, bypass grafts, indwelling stents of various types (e.g., vascular, gastrointestinal, tracheal, respiratory, urethral, genitourinary, etc.) and surgically created fistulas. Other man-made lumens may be found associated with one or more implants, such as but not limited to, partial and/or complete joint replacements (knee, hip, shoulder, ankle, etc.) and/or partial and/or complete bone replacements (spinal vertebra, femur, shin, etc.).

[0049] As used herein, the term “internal location” may include locations within the body of a subject appropriate for the placement of one or more device and/or apparatus. Internal locations may be natural and/or man-made. In illustrative embodiments, one or more devices and/or subparts may be associated with one or more manmade objects within a subject, such as but not limited to, one or more stents, screws, rods, artificial joints, etc. Such internal locations are known to those with skill in the art and/or described herein.

[0050] As used herein, the term “in proximity to” may include, but is not limited to, a space and/or area near to a defined area, such as a lesion, lumen and/or internal location. Locations that are in proximity to a lumen may include, for example, locations internal to the lumen, parts, or all, of the width of the lumen wall, and locations external to the lumen wall. In some embodiments, “in proximity to” may include distances such as, but not limited to, approximately 0.1, 1.0, 10, and/or 100 μms and/or 0.1, 1.0, 10, and/or 100 mms, and may optionally include larger and/or smaller distances depending on the energy provided (e.g. electromagnetic energy, particle beam, two-photon, pulsed, etc.) and/or the

sensitivity of detection. Those of skill in the art would know (and/or are able to calculate) the applicable distance for each form of energy.

[0051] As used herein, the term “subject” may include, but is not limited to, one or more living entities including, but not limited to, animals, mammals, humans, reptiles, birds, amphibians, and/or fish. The animals may include, but are not limited to, domesticated, wild, research, zoo, sports, pet, primate, marine, and/or farm animals. Animals include, but are not limited to, bovine, porcine, swine, ovine, murine, canine, avian, feline, equine, and/or rodent animals. Domesticated and/or farm animals include, but are not limited to, chickens, horses, cattle, pigs, sheep, donkeys, mules, rabbits, goats, ducks, geese, chickens, and/or turkeys. Wild animals include, but are not limited to, non-human primates, bear, deer, elk, raccoons, squirrels, wolves, coyotes, opossums, foxes, skunks, and/or cougars. Research animals include, but are not limited to, rats, mice, hamsters, guinea pigs, rabbits, pigs, dogs, cats and/or non-human primates. Pets include, but are not limited to, dogs, cats, gerbils, hamsters, guinea pigs and/or rabbits. Reptiles include, but are not limited to, snakes, lizards, alligators, crocodiles, iguanas, and/or turtles. Avian animals include, but are not limited to, chickens, ducks, geese, owls, sea gulls, eagles, hawks, and/or falcons. Fish include, but are not limited to, farm-raised, wild, pelagic, coastal, sport, commercial, fresh water, salt water, and/or tropical. Marine animals include, but are not limited to, whales, sharks, seals, sea lions, walruses, penguins, dolphins, and/or fish.

[0052] The dimensions and mechanical properties (e.g., rigidity) of the one or more apparatus **500** and/or devices **200**, **300**, and/or **400**, and particularly of the structural elements of the one or more apparatus and/or device, may be selected for compatibility with the location of use in order to provide for reliable positioning and/or to provide for movement of the apparatus and/or device while preventing damage to the lesion, lumen, and/or internal location and its surrounding structure. In illustrative embodiments, an apparatus and/or device may be internal or external, tethered or untethered, motile or immobile, and/or optionally ingestible.

[0053] The choice of structural element size and configuration appropriate for a particular body lumen and/or internal location may be selected by a person of skill in the art. Structural elements may be constructed using a variety of manufacturing methods, from a variety of materials. Appropriate materials may include metals, ceramics, polymers, and composite materials having suitable biocompatibility, sterilizability, mechanical, and physical properties, as will be known to those of skill in the art. Examples of materials and selection criteria are described, for example, in *The Biomedical Engineering Handbook* (Second Edition, Volume I, J. D. Bronzino, Ed., Copyright 2000, CRC Press LLC, pp. IV-1-43-31). Manufacturing techniques may include injection molding, extrusion, die-cutting, rapid-prototyping, etc., and will depend on the choice of material and device size and configuration. Sensing and energy-emitting portions of the devices as well as associated control circuitry may be fabricated on the structural elements using various microfabrication and/or MEMS techniques (see, e.g., U.S. Patent Applications 2005/0221529, 2005/0121411, 2005/0126916, and Nyitrai, et al. “Preparing Stents with Masking & Etching Technology” (2003) 26th International Spring Seminar on Electronics Technology pp. 321-324, IEEE), or

may be constructed separately and subsequently assembled to the structural elements, as one or more distinct components. See also, U.S. patent application Ser. Nos. 11/403,230 and 11/645,357.

[0054] The choice of structural element size and configuration appropriate for a motile, optionally affixable, device may be selected by a person of skill in the art. Configurations for structural elements of motile devices include, but are not limited to, a substantially tubular structure, one or more lumens in fluid communication with the body lumen, and/or an adjustable diameter (see, e.g., U.S. patent application Ser. Nos. 11/403,230 and 11/645,357). Structural elements may have the form, for example, of a short cylinder, an annulus, a cylinder, and/or a spiral. A spiral structure is disclosed, for example, in Bezrouk et al, (“Temperature Characteristics of Nitinol Spiral Stents” (2005) Scripta Medica (BRNO) 78(4):219-226. Elongated forms such as cylinders or spirals may be suitable for use in tubular lumen-containing structures such as, for example, blood vessels.

[0055] In addition to materials disclosed above, flexible material having adjustable diameter, taper, and length properties may be used as part of the structural material. For example, some materials may change from a longer, narrower configuration, to a shorter, wider configuration, or may taper over their length. Structural elements that may exhibit this type of expansion/contraction property may include mesh structures formed of various metals or plastics, and some polymeric materials, for example (see, e.g., “Agile new plastics change shape with heat” MIT News Office (Nov. 20, 2006) pp. 1-4; MIT Tech Talk (Nov. 22, 2006) p. 5; <http://web.mit.edu/newsoffice/2006/triple-shape.html>; and Shanpoor et al., Smart Materials and Structures (2005) 14:197-214, Institute of Physics Publishing).

[0056] In some embodiments, the structural element may include a self-expanding material, a resilient material, or a mesh-like material. Flexibility may also be conferred by configuration as well as material; the structural element may include a slotted structure and/or mesh-like material, for example. Structural elements may be formed from various materials, including metals, polymers, fabrics, and various composite materials, including ones of either inorganic or organic character, the latter including materials of both biologic and abiologic origin, selected to provide suitable biocompatibility and mechanical properties. The structural element may include a biocompatible material, and may include a bioactive component (such as a drug releasing coating or bioactive material attached to or incorporated into the structural element).

[0057] It is contemplated that additional components, such as energy sources **110**, sensors **120**, control circuitry **130**, power sources **140**, and/or motive sources **150** (e.g. propelling mechanisms), for example, will be attached, connected to, place within, manufactured on or in, and/or formed integrally with the structural element. Methods for manufacture and/or assembly are known in the art and/or described herein.

[0058] Embodiments of one or more apparatus **100** and/or **500** and/or devices **200**, **300**, and/or **400** may include one or more energy sources **110**. One or more energy sources **110** may include, but are not limited to, one or more electromagnetic energy sources **111** and/or one or more charged particle energy sources **112**. One or more electromagnetic

energy sources **111** may include, but are not limited to, one or more optical energy sources **113** and/or one or more X-ray energy sources **115**. One or more optical energy sources **113** may include, but are not limited to, one or more visual energy sources **114**. In some embodiments one or more electromagnetic energy source **111** is a laser.

[0059] In some embodiments, one or more apparatus **100** and/or **500** is, in whole or in part, handheld. In some embodiments one or more energy source **110**, optionally one or more electromagnetic energy source **111**, is handheld. In some embodiments one or more energy source **110**, optionally one or more electromagnetic energy source **111**, is in the same handheld unit. In some embodiments one or more energy source **110**, optionally one or more electromagnetic energy source **111**, is in a different handheld unit.

[0060] In some embodiments, one or more energy sources **110** optionally provide energy for excitation of a fluorescent response **116**, energy for targeting **118**, and/or energy for ablation **117** of one or more targets. In some embodiments, one energy source **110** provides excitation energy **116**, targeting energy **118**, and ablation energy **117**. In some embodiments, different energy sources **110** provide excitation energy **116**, targeting energy **118**, and ablation energy **117**. In some embodiments, one energy source **110** provides excitation energy **116** and ablation energy **117**, and optionally targeting energy **118**. In some embodiments, more than one energy source **110** provides excitation energy **116**. In some embodiments, more than one energy source provides ablation energy **117**.

[0061] In some embodiments, one or more electromagnetic energy sources **111** provide one or more of excitation energy **116**, ablation energy **117**, and/or targeting energy **118**. In some embodiments, one or more optical energy sources **113** (optionally visual energy sources **114**) provide one or more of excitation energy **116**, ablation energy **117**, and/or targeting energy **118**. In some embodiments, one or more X-ray energy sources **115** provide ablation energy. In some embodiments, one or more particle beam sources **112** provide ablation energy.

[0062] In some embodiments, one or more energy sources **110** are programmable, remote-controlled, wirelessly controlled, and/or feedback-controlled.

[0063] As used herein, the term “electromagnetic energy” may include radio waves, microwaves, terahertz radiation, infrared radiation, visible light, X-rays, and gamma rays. In some embodiments, one or more of these frequencies may be explicitly excluded from the general category of electromagnetic energy (e.g. electromagnetic energy sources, but not including X-ray energy sources). Electromagnetic energy (or radiation) with a wavelength between approximately 400 nm and 700 nm is detected by the human eye and perceived as visible light. Optical light may also include near infrared (longer than 700 nm) and ultraviolet (shorter than 400 nm). In illustrative embodiments, electromagnetic energy is generated at one or more wavelengths of approximately 100-280 nm, 180-350 nm, 200-340 nm, 250-400 nm, 250-450 nm, 280-315 nm, 280-540 nm, 300-460 nm, 300-600 nm, 300-700 nm, 310-510 nm, 315-400 nm, 350-390 nm, 350-700 nm, 360-370 nm, 360-600 nm, 375-425 nm, 375-440 nm, 400-1000 nm, 407-420 nm, 410-430 nm, 445-470 nm, 450-490 nm, 450-560 nm, 455-490 nm, 465-495 nm, 490-690 nm, 505-550 nm, 515-555 nm, 580-600

nm, 600-1600 nm, 250 nm, 265 nm, 290 nm, 330 nm, 335 nm, 337 nm, 340 nm, 350 nm, 352 nm, 360 nm, 365 nm, 385 nm, 395 nm, 400 nm, 405 nm, 410 nm, 420 nm, 430 nm, 435 nm, 436 nm, 440 nm, 444 nm, 450 nm, 455 nm, 460 nm, 465 nm, 469 nm, 470 nm, 480 nm, 481 nm, 483 nm, 485 nm, 486 nm, 487 nm, 488 nm, 490 nm, 495 nm, 500 nm, 506 nm, 514 nm, 516 nm, 520 nm, 530 nm, 538 nm, 545 nm, 546 nm, 550 nm, 560 nm, 570 nm, 581 nm, 585 nm, 600 nm, 609 nm, 610 nm, 620 nm, 630 nm, 632 nm, 635 nm, 636 nm, 640 nm, 644 nm, 665 nm, 670 nm, 700 nm, 880 nm, 950 nm, 1064 nm, 1320 nm, 2070 nm, and/or 2940 nm, among others.

[0064] As used herein, the term “charged particle” may include particles generated using one or more particle beams. A particle beam is optionally an accelerated stream of charged particles or atoms that may be directed by magnets and focused by electrostatic lenses, although they may also be self-focusing. Particle beams may be high energy beams (e.g. created in particle accelerators), medium and/or low energy beams.

[0065] Electromagnetic or optical energy is made up of photons. Electromagnetic energy includes, but is not limited to, single photon electromagnetic energy, two photon electromagnetic energy, multiple wavelength electromagnetic energy, and extended-spectrum electromagnetic energy. Electromagnetic energy may be used for excitation of fluorescence, targeting, and/or for ablation of one or more targets. As used herein, the term “fluorescence” may include the production of light (emission) following excitation by electromagnetic energy. Fluorescence may result from emissions from exogenously provided tags and/or markers, and/or an inherent response of one or more targets to excitation with electromagnetic energy. As used herein, the term “auto-fluorescence” may include an inherent fluorescent response from one or more targets.

[0066] Electromagnetic energy sources **111** may be configured to emit energy as a continuous beam or as a train of short pulses. In the continuous wave mode of operation, the output is relatively consistent with respect to time. In the pulsed mode of operation, the output varies with respect to time, optionally having alternating ‘on’ and ‘off’ periods. In illustrative examples, one or more energy sources are configured to emit pulsed energy to specifically ablate a limited area and/or a limited number of target cells. In illustrative examples, one or more energy sources are configured to emit continuous energy to excite endogenous fluorophores to emit fluorescence.

[0067] One or more electromagnetic energy sources **111** may include one or more lasers having one or more of a continuous or pulsed mode of action. One or more pulsed lasers may include, but are not limited to, Q-switched lasers, mode locking lasers, and pulsed-pumping lasers. Mode locked lasers emit extremely short pulses on the order of tens of picoseconds down to less than 10 femtoseconds, the pulses optionally separated by the time that a pulse takes to complete one round trip in the resonator cavity. Due to the Fourier limit, a pulse of such short temporal length may have a spectrum which contains a wide range of wavelengths.

[0068] In some embodiments, the electromagnetic energy is focused at a depth of approximately 0.1 mm, 0.2 mm, 0.3 mm, 0.4 mm, 0.5 mm, 0.6 mm, 0.7 mm, 0.8 mm, 0.9 mm, 1.0 mm, 1.1 mm, 1.2 mm, 1.3 mm, 1.4 mm, 1.5 mm, 1.6 mm, 1.7 mm, 1.8 mm, 1.9 mm, 2.0 mm, 2.1 mm, 2.2 mm, 2.3 mm,

2.4 mm, 2.5 mm, 2.6 mm, 2.7 mm, 2.8 mm, 2.9 mm, or 3.0 mm below the surface of the lesion, beyond the surface of a wall of the lumen, and/or beyond a surface of an internal location. In some embodiments, the electromagnetic energy is focused at a depth of approximately 0.1 to 3 mm, 0.1 to 2.5 mm, 0.1 to 2.0 mm, 0.1 to 1.5 mm, 0.1 to 1.0 mm, 0.1 to 0.5 mm, 0.5 to 3.0 mm, 0.5 to 2.5 mm, 0.5 to 2.0 mm, 0.5 to 1.5 mm, 0.5 to 1.0 mm, 1.0 to 3.0 mm, 1.0 to 2.5 mm, 1.0 to 2.0 mm, 1.0 to 1.5 mm, 1.5 to 3.0 mm, 1.5 to 2.5 mm, 1.5 to 2.0 mm, 2.0 to 3.0 mm, 2.0 to 2.5 mm, or 2.5 to 3.0 mm below the surface of the lesion, beyond the surface of a wall of the lumen, and/or beyond a surface of an internal location.

[0069] In some embodiments, the electromagnetic energy is generated by two photons having the same wavelength. In some embodiments, the electromagnetic energy is generated by two photons having a different wavelength. Electromagnetic energy generated by two photons is optionally focused at a depth below the surface of the lesion, beyond the surface of a wall of the lumen, and/or beyond a surface of an internal location, optionally at one or more depths as described above and/or herein.

[0070] As used herein, the term “two-photon” may include excitation of a fluorophore by two photons in a quantum event, resulting in the emission of a fluorescence photon, optionally at a higher energy than either of the two excitatory photons, optionally using a femtosecond laser. In some embodiments, two photon electromagnetic energy is coupled through a virtual energy level and/or coupled through an intermediate energy level.

[0071] As used herein, the term “extended-spectrum” may include a range of possible electromagnetic radiation wavelengths within the full spectrum of possible wavelengths, optionally from extremely long to extremely short. One of skill in the art is able to select appropriate ranges for the devices and methods disclosed herein based on information publicly available and/or disclosed herein.

[0072] In some embodiments, the electromagnetic energy may be defined spatially and/or directionally. In some embodiments, the electromagnetic energy may be spatially limited, optionally spatially focused and/or spatially collimated. In illustrative embodiments, the electromagnetic energy optionally contacts less than less than an entire possible area, or an entire possible target, and/or is limited to a certain depth within a tissue.

[0073] In some embodiments, the electromagnetic energy may be directionally limited, directionally varied, and/or directionally variable. In illustrative embodiments, the electromagnetic energy may be provided only in a single direction, for example 90 degrees from the horizontal axis of a device, or toward a lumen wall, a lesion, or an internal location. In illustrative embodiments, the electromagnetic energy may be provided over a range of directions for example, through movement of the electromagnetic source, through movement of the entire device (e.g. rotation, random movement, wobbling, tumbling), and/or through illumination from a variety of sources in the device.

[0074] Electromagnetic energy configured to induce a fluorescent response in a target may be selected, optionally manually, remotely, programmably, wirelessly, and/or using feedback information. Frequencies that induce a fluorescent response in one or more targets are known in the art and/or

discussed herein. In some embodiments, selection of excitation energy 116 may be performed in advance, or as a result of information received, optionally including feedback information, optionally from one or more sensors 120.

[0075] Electromagnetic energy and/or particle beam energy configured to ablate one or more targets may be selected, optionally manually, remotely, programmably, wirelessly, and/or using feedback information. Frequencies useful to at least partially ablate one or more targets are known in the art and/or discussed herein. In some embodiments, selection of ablation energy 117 may be performed in advance, or as a result of information received, optionally including feedback information, optionally from one or more sensors 120.

[0076] In addition to electromagnetic energy described herein, the ablation energy may be supplied by energetic charged particles, such as electrons, protons, or other ions. In one embodiment, the charged particles are directed towards the autofluorescent target in the form of particle beams. In another embodiment, the charged particles are emitted over relatively wide solid-angles, and address the designated autofluorescent target by virtue of spatial proximity.

[0077] In one embodiment, particle beams are generated outside the body by beam generators such as particle accelerators, cathode ray tubes, electrostatic accelerators, voltage-multiplier accelerators, Cockcroft-Walton accelerators, Van de Graaff accelerators, Alvarez accelerators, linear accelerators, circular accelerators, wakefield accelerators, collimated radioactive emitters, etc. The beams from these sources can be directed towards the autofluorescent target by mechanical, electrical, or magnetic methods. In some embodiments, the particle beams may be generated and directed from locations separate from the light source used to induce the autofluorescent response. In other embodiments, the particle beam may be generated in proximity to the autofluorescence inducing light source, by using compact particle sources such as electrostatic accelerators, Alvarez accelerators, linear accelerators, voltage-multiplier accelerators, Cockcroft-Walton accelerators, wakefield accelerators, collimated radioactive emitters, etc.

[0078] In some embodiments, particle beams are generated and delivered from inside the body. Compact particle beam generators such as electrostatic accelerators, Alvarez accelerators, linear accelerators, voltage-multiplier accelerators, Cockcroft-Walton accelerators, or wakefield accelerators can be used. In one embodiment of a voltage-multiplier accelerator, the staged voltage elements can use high-field-strength capacitors. In another embodiment, the staged voltages can be generated in an array of photocells by photogeneration using on-board or off-board light sources. In another embodiment of an in-vivo particle source, a radioactive emitter can be used to provide a charged particle source. One example of such a source is the Beta-Cath™ System, developed by Novoste Corp.

[0079] In one embodiment, in-vivo radioactive sources can be encapsulated within shielding which can be used to control charged particle exposure to nearby tissue. The shielding can have one or more portals, allowing for collimated emission. The shielding can be movable, either across all or part of its extent, or across one or more portal openings, in order to provide switchable particle sources.

Shielding can be controllably moved by mechanical techniques such as valves, shutters, or similar devices, can utilize movable liquids, such as Hg, or utilize other methods. The particles from these in-vivo sources can be directed towards the autofluorescent target by mechanical, electrical, or magnetic methods, or may rely upon proximity.

[0080] Embodiments of one or more apparatus **100** and/or **500** and/or devices **200**, **300**, and/or **400** may include one or more targeting electromagnetic energy sources **118**. Targeting electromagnetic energy is optionally from one or more optical energy sources **113**, optionally from one or more visible light sources **114**. In some embodiments, the one or more targeting energy source **118** is aligned with the excitation energy source **116** and/or the ablation energy source **117**. In illustrative embodiments, the targeting energy source **118** provides a visual indication of the directional alignment of the excitation energy **116** to induce a fluorescent response, and/or the ablation energy **117** to at least partially ablate one or more targets.

[0081] In some embodiments, the one or more targeting energy source **118** has the same spatial extent as the excitation energy **116** and/or the ablation energy **117**. In some embodiments, the one or more targeting energy source **118** has a different spatial extent than the excitation energy **116** and/or the ablation energy **117**. In illustrative embodiments, the targeting energy is a visually detectable beam of light that is narrower than the excitation energy and/or ablation energy beam. In illustrative embodiments, the targeting energy is a visually detectable beam of light that is focused at the midpoint of the excitation and/or ablation energy beam. In illustrative embodiments, the targeting energy is a visually detectable beam of light that is broader than the excitation and/or ablation energy beam.

[0082] Embodiments of one or more apparatus **100** and/or **500** and/or devices **200**, **300**, and/or **400** may include one or more sensors **120**. In some embodiments, one or more sensors **120** are the same sensor. In some embodiments, one or more sensors **120** are different sensors. In some embodiments, one or more sensors are in the same unit, optionally a handheld unit. In some embodiments, one or more sensors **120** are in separate units. In some embodiments, one or more sensors **120** are in the same and/or different units than one or more energy sources **110**.

[0083] The one or more sensors may include, but are not limited to, electromagnetic energy detectors **121** (e.g. optical energy such as near IR, UV, visual), pH detectors **122**, chemical and biological molecule detectors **123** (e.g. blood chemistry, chemical concentration, biosensors), physiological detectors **124** (e.g. blood pressure, pulse, peristaltic action, pressure sensors, flow sensors, viscosity sensors, shear sensors), time detectors **125** (e.g. timers, clocks), imaging detectors **126**, acoustic sensors **127**, temperature sensors **128**, and/or electrical sensors **129**. One or more sensors may be configured to measure various parameters, including, but not limited to, the electrical resistivity of the fluid, the density or sound speed of the fluid, the pH, the osmolality, or the index of refraction of the fluid at least one wavelength. The selection of a suitable sensor for a particular application or use site is considered to be within the capability of a person having skill in the art. One or more of these and/or other sensing capabilities may be present in a single sensor or an array of sensors; sensing capabilities are not limited to a particular number or type of sensors.

[0084] One or more biosensors **123** may detect materials including, but not limited to, a biological marker, an antibody, an antigen, a peptide, a polypeptide, a protein, a complex, a nucleic acid, a cell (and, in some cases, a cell of a particular type, e.g. by methods used in flow cytometry), a cellular component, an organelle, a gamete, a pathogen, a lipid, a lipoprotein, an alcohol, an acid, an ion, an immunomodulator, a sterol, a carbohydrate, a polysaccharide, a glycoprotein, a metal, an electrolyte, a metabolite, an organic compound, an organophosphate, a drug, a therapeutic, a gas, a pollutant, or a tag. A biosensor **123** may include an antibody or other binding molecule such as a receptor or ligand.

[0085] One or more sensors optionally include, in part or whole, a gas sensor such as an acoustic wave, chemiresistant, or piezoelectric sensors, or an electronic nose. One or more sensors are optionally small in size, for example a sensor or array that is a chemical sensor (Snow (2005) *Science* 307:1942-1945), a gas sensor (Hagleitner, et al. (2001) *Nature* 414:293-296.), an electronic nose, and/or a nuclear magnetic resonance imager (Yusa (2005), *Nature* 434:1001-1005). Further examples of sensors are provided in *The Biomedical Engineering Handbook*, Second Edition, Volume I, J. D. Bronzino, Ed., Copyright 2000, CRC Press LLC, pp. V-1-51-9, and U.S. Pat. No. 6,802,811).

[0086] One or more electromagnetic energy sensors **121** may be configured to measure the absorption, emission, fluorescence, or phosphorescence of one or more targets. Such electromagnetic properties may be inherent properties of all or a portion of one or more targets (e.g. autofluorescence), or may be associated with materials added or introduced to the body, surface, lumen, interior, and/or fluid, such as tags or markers for one or more targets. One or more targets may include, but are not limited to, at least a portion of one or more of a wound, a lesion, and/or an incision, one or more internal surfaces, one or more lumen fluids, one or more cells, one or more lumen walls, and/or one or more other interior locations.

[0087] In some embodiments, one or more sensors **120** are configured to detect a fluorescent response at a single wavelength of electromagnetic energy, at two wavelengths of electromagnetic energy, at multiple wavelengths of electromagnetic energy, or over extended-spectrum electromagnetic energy. In some embodiments, one or more sensors **120** are configured to detect excitation energy, ablation energy, and/or targeting energy. In illustrative embodiments, one or more sensors are configured to detect wavelengths of approximately 100-280 nm, 180-350 nm, 200-340 nm, 250-400 nm, 250-450 nm, 280-315 nm, 280-540 nm, 300-460 nm, 300-600 nm, 300-700 nm, 310-510 nm, 315-400 nm, 350-390 nm, 350-700 nm, 360-370 nm, 360-600 nm, 375-425 nm, 375-440 nm, 400-1000 nm, 407-420 nm, 410-430 nm, 445-470 nm, 450-490 nm, 450-560 nm, 455-490 nm, 465-495 nm, 490-690 nm, 505-550 nm, 515-555 nm, 580-600 nm, 600-1600 nm, 250 nm, 265 nm, 290 nm, 330 nm, 335 nm, 337 nm, 340 nm, 350 nm, 352 nm, 360 nm, 365 nm, 385 nm, 395 nm, 400 nm, 405 nm, 410 nm, 420 nm, 430 nm, 435 nm, 436 nm, 440 nm, 444 nm, 450 nm, 455 nm, 460 nm, 465 nm, 469 nm, 470 nm, 480 nm, 481 nm, 483 nm, 485 nm, 486 nm, 487 nm, 488 nm, 490 nm, 495 nm, 500 nm, 506 nm, 514 nm, 516 nm, 520 nm, 530 nm, 538 nm, 545 nm, 546 nm, 550 nm, 560 nm, 570 nm, 581 nm, 585 nm, 600 nm, 609 nm, 610 nm, 620 nm, 630 nm, 632 nm, 635 nm, 636 nm, 640 nm,

644 nm, 665 nm, 670 nm, 700 nm, 880 nm, 950 nm, 1064 nm, 1320 nm, 2070 nm, and/or 2940 nm.

[0088] In some embodiments, one or more sensors **120** are configured to detect a cumulative fluorescent response over a time interval. In some embodiments, one or more sensors **120** are configured to detect a fluorescent response at a specific time interval and/or at a specific time. In some embodiments, one or more sensors **120** are configured to detect a time-dependent fluorescent response. In illustrative embodiments, the cumulative fluorescent response is determined over milliseconds, seconds, and/or minutes following excitation. In some embodiments, the fluorescent response is detected over millisecond, second, and/or minute time intervals following excitation. In some embodiments, the fluorescent response is detected approximately femtoseconds, picoseconds, nanoseconds, milliseconds, seconds, and/or minutes after excitation.

[0089] In some embodiments, one or more sensors **120** are configured to be calibrated optionally at least partially based on an expected baseline fluorescence (e.g. normal fluorescence) for the fluid, tissue, cells, internal location, lesion, and/or lumen. As used herein, the term “normal fluorescence” may include the intrinsic fluorescence of one or more fluid, tissue, cells, internal location, lesion, and/or lumen as determined by researchers and/or medical or veterinary professionals for subjects of a certain age, ethnicity, etc. who do not have pathological conditions (e.g. control subjects). “Normal fluorescence” may include the intrinsic fluorescence of fluid, tissue, cells, internal location, lesion, and/or lumen of a subject prior to a pathological condition and/or of a comparable location not affected by the pathological condition.

[0090] Embodiments of one or more apparatus **100** and/or **500** and/or devices **200**, **300**, and/or **400** may be configured to detect a condition of interest including, but not limited to, a temperature, a pressure, a fluid flow, an optical absorption, optical emission, fluorescence, or phosphorescence, an index of refraction at least one wavelength, an electrical resistivity, a density or sound speed, a pH, an osmolality, the presence of an embolism, the presence (or absence) of an object (such as a blood clot, a thrombus, an embolus, a plaque, a lipid, a kidney stone, a dust particle, a pollen particle, a gas bubble, an aggregate, a cell, a specific type of cell, a cellular component or fragment, a collection of cells, a gamete, a pathogen, or a parasite), and/or the presence (or absence) of a substance such as a biological marker, an antibody, an antigen, a peptide, a polypeptide, a protein, a complex, a nucleic acid, a cell (and, in some cases, a cell of a particular type, e.g. by methods used in flow cytometry), a cellular component, an organelle, a gamete, a pathogen, a lipid, a lipoprotein, an alcohol, an acid, an ion, an immunomodulator, a sterol, a carbohydrate, a polysaccharide, a glycoprotein, a metal, an electrolyte, a metabolite, an organic compound, an organophosphate, a drug, a therapeutic, a gas, a pollutant, or a tag, for example.

[0091] As used herein, the term “target” may include a condition and/or material of interest. Materials of interest may include, but are not limited to, materials identifiable by their autofluorescent emissions (individually or as an aggregate signal), or through the use of tags detectable through fluorescence. Such materials may include, but are not limited to, target cells, target tissues, and/or target areas. Such

targets may include, but are not limited to, a blood clot, a thrombus, an embolus, a plaque, a lipid, a kidney stone, a dust particle, a pollen particle, an aggregate, a cell, a specific type of cell, a cellular component, an organelle, a collection or aggregation of cells or components thereof, a gamete, a pathogen, or a parasite.

[0092] One or more targets may include, but are not limited to, cancer, microbial cells, infected cells, and/or atherosclerotic cells. One or more cancer cells may include, but are not limited to, neoplastic cells, metastatic cancer cells, precancerous cells, adenomas, and/or cancer stem cells. Cancer types may include, but are not limited to, bladder cancer, breast cancer, colon cancer, rectal cancer, endometrial cancer, kidney (renal) cancer, lung cancer, leukemia, melanoma, non-Hodgkin's Lymphoma, pancreatic cancer, prostate cancer, skin (non-melanoma) cancer, and thyroid cancer. Cancers may include, but are not limited to, bone, brain, breast, digestive, gastrointestinal, endocrine, eye, genitourinary, germ line, gynecological, head and neck, hematologic/blood, leukemia, lymphoma, lung, musculoskeletal, neurologic, respiratory/thoracic, skin, and pregnancy-related. Microbial cells (microorganisms) may include, but are not limited to, bacteria, protists, protozoa, fungi, and/or amoeba. Pathogens may include, but are not limited to, bacteria, viruses, parasites, protozoa, fungi, and/or proteins. Bacteria may include, but are not limited to, *Escherichia coli*, *Salmonella*, *Mycobacterium* spp., *Bacillus anthracis*, *Streptococcus* spp., *Staphylococcus* spp., *Francisella tularensis*, and/or *Helicobacter pylori*. Viruses may include, but are not limited to, Hepatitis A, B, C, D, and/or E, Influenza virus, Herpes simplex virus, Molluscum contagiosum, and/or Human Immunodeficiency virus. Protozoa may include, but are not limited to, *Cryptosporidium*, *Toxoplasma* spp., *Giardia lamblia*, *Trypanosoma* spp., *Plasmodia* spp. and/or *Leishmania* spp. Fungi may include, but are not limited to, *Pneumocystis* spp., *Tinea*, *Candida* spp., *Histoplasma* spp., and/or *Cryptococcus* spp. Parasites may include, but are not limited to tapeworms and/or roundworms. Proteins may include, but are not limited to, prions.

[0093] As used herein, the term “fluid” may refer to liquids, gases, and other compositions, mixtures, or materials exhibiting fluid behavior. The fluid within the body lumen may include a liquid, or a gas or gaseous mixtures. As used herein, the term fluid may encompass liquids, gases, or mixtures thereof that also include solid particles in a fluid carrier. Liquids may include mixtures of two or more different liquids, solutions, slurries, or suspensions. Examples of liquids present within body lumens include, but are not limited to, blood, lymph, serum, urine, semen, digestive fluids, tears, saliva, mucous, cerebro-spinal fluid, intestinal contents, bile, epithelial exudate, or esophageal contents. Liquids present within body lumens may include synthetic or introduced liquids, such as blood substitutes, or drug, nutrient, fluorescent marker, or buffered saline solutions. Fluids may include liquids containing dissolved gases or gas bubbles, or gases containing fine liquid droplets or solid particles. Gases or gaseous mixtures found within body lumens may include inhaled and exhaled air, e.g. in the nasal or respiratory tract, or intestinal gases.

[0094] Embodiments of one or more apparatus **100** and/or **500** and/or device **200**, **300**, and/or **400** may include control circuitry **130**. In some embodiments, the control circuitry is configured to control one or more of one or more energy

sources **110**, one or more sensors **120**, and/or one or more power sources **140**. In some embodiments, the control circuitry **130** may be directly coupled, indirectly coupled, and/or wirelessly coupled to one or more energy sources **110**, one or more sensors **120**, and/or one or more power sources **140**. Control circuitry **130** may be electrical circuitry and/or other types of logic/circuitry including, for example, fluid circuitry, chemo-mechanical circuitry, and other types of logic/circuitry that provide equivalent functionality. The control circuitry **130** may include at least one of hardware, software, and firmware; in some embodiments the control circuitry may include a microprocessor. The control circuitry **130** may be located in or on the structural element of a device and/or at a location separate from the structural element. Various operation flows (e.g. **600**, **700**, and/or **800**) operable on control circuitry **130** are described herein and/or known in the art.

[**0095**] In some embodiments, the control circuitry **130** is responsive to identify a target, target area, and/or target cells, molecules, and/or tissues. In some embodiments, the control circuitry **130** identifies a target, target area, and/or target cells, molecules, and/or tissues by determining one or more of the direction, the distance, the tissue depth, the time, and/or the coordinates from which a fluorescent response originated, optionally in relation to the excitation energy **116** and/or the targeting energy **118**. In some embodiments, the control circuitry **130** identifies a target, target area, and/or target cells, molecules, and/or tissues by analysis of one or more characteristics of a fluorescent response (e.g. presence and/or absence of a fluorescent response and/or density of a fluorescent response—grouping of cells that if non-grouped would not be considered a target), optionally including but not limited to, the electromagnetic spectrum, or parts thereof, of a fluorescent response. In some embodiments, the control circuitry **130** identifies a target, target area, and/or target cells, molecules, and/or tissues in real time.

[**0096**] In some embodiments, the control circuitry **130** is responsive to select one or more characteristics of ablation energy **117** for at least partially ablating a target, target area, and/or target cells, molecules, and/or tissues. In some embodiments, the control circuitry **130** selects one or more characteristics of ablation energy **117** for at least partially ablating a target, target area, and/or target cells, molecules, and/or tissues responsive to one or more characteristics of the fluorescent response and/or the electromagnetic energy selected to elicit the fluorescent response. In some embodiments, the control circuitry **130** increases the ablation energy **117** responsive to an increase in the fluorescent response, and/or decreases the ablation energy **117** responsive to a decrease in the fluorescent response. In some embodiments, the control circuitry **130** selects one or more characteristics of the ablation energy **117** at least partially responsive to detection of one or more wavelengths of the fluorescent response.

[**0097**] In some embodiments, the control circuitry **130** is responsive to update targeting information on the basis of movement of part or all of an apparatus **100**, and/or **500** and/or a device **100**, **200**, and/or **300** and/or a target and/or target area. In illustrative embodiments, such target updating may be useful when the ablating energy **117** may be delivered at a time substantially later than the time at which autofluorescence radiation is detected, or when the target is moving in relation to the ablation energy source **117**. In this

case, the detected location must be updated to take into account possible motion of the target area and/or the device.

[**0098**] Motion of the autofluorescence location can be updated by registering the detected autofluorescence location relative to other, updatable, location information. In one example, the detected autofluorescence location is registered relative to fiducials on or within the individual. Then, the location of the fiducials is updated, and the site of the autofluorescence location at such time can be predicted based upon its known registration relative to the fiducial locations. In another example, the detected autofluorescence location is registered relative to features within an image of a related portion of the individual. Then, the image is updated and the location of the autofluorescence location at such time can be predicted based upon its known registration relative to the image features.

[**0099**] Motion, which may include location and/or orientation, of the device can be updated by a variety of methods, including inertial navigation, measurements based on beacons or fiducials, measurements based on orientation sensors, or combinations of such techniques. Inertial navigation can be performed with the support of accelerometers on the device, and may also incorporate use of gyroscopic sensors on the device. Beacons and/or fiducials can be used to measure the device's motion; the beacons or fiducials may be on the device and their location or direction measured by remote sensors. Alternatively, measurements of remote beacons or fiducials may be made by sensors on the device. Combined systems may be used, with mixtures of remote and on-board sensors, measuring the location or direction of remote or on-board beacons or fiducials. Orientation sensors, such as tilt sensors may be used to provide information of one or more aspects of the device's orientation. Motion information obtained from different sources or methods can be combined together to give improved motion estimates, using techniques such as nonlinear filtering, least-squares filtering, Kalman filtering, etc.

[**0100**] The updated autofluorescence location may then be combined, via a coordinate translation and rotation, with the updated position and location of the device. This results in updated coordinates or directions of the autofluorescence location with respect to the device, and can be used to direct the delivery of ablation energy.

[**0101**] In some embodiments, control circuitry receives information from one or more sensors and/or one or more external sources. Information may include, but is not limited to, a location of an untethered device, allowable dose limits (e.g. of energy for excitation and/or ablation and/or targeting), release authority (e.g. for release of energy for excitation, ablation, and/or targeting, and/or release from a tethered location, or from an affixed and/or stationary location), control parameters (e.g. for energy release, for motion, for power, for sensors, etc.), operating instructions, and/or status queries.

[**0102**] In some embodiments, control circuitry is feedback controlled, optionally from information from one or more sensors, and/or one or more external sources. In some embodiments, control circuitry is monitored by one or more external sources, provides outputs to one or more sources, and/or sends outputs to one or more sources. In some embodiments control circuitry is remote-controlled, wirelessly controlled, programmed, and/or automatic.

[0103] Embodiments of one or more apparatus **100** and/or **500** and/or devices **200**, **300** and/or **400** optionally include a power source **140**. One or more power sources may be configured to provide power to one or more of one or more motive sources, one or more control circuitry, one or more sensor, and/or one or more energy source.

[0104] Power sources **140** may include, but are not limited to, one or more batteries **141**, fuel cells **142**, energy scavenging **143**, electrical **144**, and/or receivers **145** located on and/or in the one or more apparatus and/or devices or separately from the one or more apparatus and/or devices. The one or more batteries may include a microbattery such as those available from Quallion LLC (<http://www.quallion.com>), may be designed as a film (U.S. Pat. Nos. 5,338,625 and 5,705,293), or may be a nuclear battery. The one or more fuel cells may be enzymatic, microbial, or photosynthetic fuel cells or other biofuel cells (US2003/0152823A1; WO03106966A2 Miniature Biofuel cell; Chen T et al. J. Am. Chem. Soc. 2001, 123, 8630-8631, A Miniature Biofuel Cell), and may be of any size, including the micro- or nano-scale.

[0105] The one or more energy-scavenging devices may include a pressure-rectifying mechanism that utilizes pulsatile changes in blood pressure, for example, or an acceleration-rectifying mechanism as used in self-winding watches, or other types of flow rectifying mechanisms capable of deriving energy from other flow parameters. The one or more electrical power sources may be located separately from the structural element of the device and connected to the structural element by a wire, or an optical power source located separately from the structural element and connected to the structural element by a fiber-optic line or cable. The one or more power receivers may be capable of receiving power from an external source, acoustic energy from an external source, and/or a power receiver capable of receiving electromagnetic energy (e.g., infrared energy) from an external source.

[0106] In illustrative embodiments, one or more power sources **140** are optionally part of and/or are configured to propel, move, and/or provide power to one or more motive sources **150**. One or more of the propelling mechanisms may include mechanical or micromechanical structures driven by at least one motor, micromotor, or molecular motor, or by expansion or change in configuration of a shape change polymer or metal. A molecular motor may be a biomolecular motor that runs on a biological chemical such as ATP, kinesin, RNA polymerase, myosin dynein, adenosinetriphosphate synthetase, rotaxanes, or a viral protein. In illustrative embodiments, one or more power sources **140** are configured to power one or more rotary motors, propellers, thrusters, and/or provide for jet propulsion, among others.

[0107] In some embodiments, the power source **140** optionally includes a power transmitter capable of transmitting power from one or more device to a secondary location. The power transmitter may be capable of transmitting at least one of acoustic power, electrical power, or optical power. The secondary location may be, for example, another device within the body, either in a body lumen or elsewhere that includes a power receiver and structures for using, storing and/or re-transmitting the received power.

[0108] Embodiments of one or more devices **200**, **300** and/or **400** may include one or more motive sources **150**.

The one or more motive sources **150** are configured for the type and nature of the lumen and/or internal location to be traveled. A lumen and/or internal location having a relatively uniform cross-section (height and/or width) over the length to be traveled may be traversed by most propelling mechanisms including, but not limited to, mechanisms that engage the lumen wall on more than one and/or several sides, that engage the lumen wall on one side only, that are able to change shape/size (see, e.g., U.S. Patent Application 2005/0177223), and/or that employ more than one means of propulsion. A lumen and/or internal location that varies significantly in cross-section over the length to be traveled may be traversed using some propelling mechanisms including, but not limited to, those that walk or roll along one side of a lumen, those that are able to change shape/size, and/or those that employ more than one mode of propulsion.

[0109] In illustrative embodiments, one or more motive sources **150** may encompass part or all of the structural elements of one or more devices **200**, **300**, and/or **400**. For example, one or more structural elements of one or more devices may be substantially cylindrical, and hollow and tubular in configuration, with a single central opening, optionally allowing the exterior of the cylindrical structural element to contact and engage the wall of a lumen, and the interior of the structural element (within the single central opening) to optionally form a fluid-contacting portion of the structural element. Optionally, one or more structural elements of one or more devices may be approximately hemispherical or hemi-ellipsoid, optionally allowing a portion of its cross-section to contact and/or engage the wall of a lumen without obstructing the movement of fluid within the body lumen. Optionally, one or more structural elements of one or more devices may be pill- or capsule-shaped, and adapted to move through a central portion of a body lumen. Lumen wall engaging portions may include, but are not limited to, rotating wheels, projections (e.g. arms), springs, hooks (e.g. claws), and/or tissue adhesives that are configured to engage wall portions and optionally to provide mobility to one or more devices.

[0110] A variety of motive sources **150** applicable for one or more devices are known in the art and/or described herein. See, for example, U.S. Pat. Nos. 5,337,732; 5,386,741; 5,662,587; and 6,709,388; and Kassim, et al. "Locomotion Techniques for Robotic Colonoscopy"; IEEE Engineering in Med & Biol. Mag. (2006) pp. 49-56; Christensen "Musclebot: Microrobot with a Heart" (2004) Technology.com, pp. 1-2 located at <http://www.technovelgy.com/ct/Science-Fiction-News.asp?NewsNum=46>; Ananthaswamy "First robot moved by muscle power" (2004), pp. 1-3; New Scientist; located at <http://www.newscientist.com/article.nsf?id=dn4714>; and Freitas "8.2.1.2 Arteriovenous Microcirculation"; "9.4.3.5 Legged Ambulation"; "9.4.3.6 Tank-Tread Rolling"; "9.4.3.7 Amoeboid Locomotion"; "9.4.3.8 Inchworm Locomotion"; "Nanomedicine Volume I: Basic Capabilities" (1999) pp. 211-214, pp. 316-318; Landes Bioscience; Georgetown, Tex., USA.

[0111] One or more motive source **150** may include, but is not limited to, one or more propelling mechanisms such as one or more cilium-like structures (see, e.g., U.S. Patent Application 2004/0008853; Mathieu, et al. "MRI Systems as a Mean of Propulsion for a Microdevice in Blood Vessels" (2003) pp. 3419-3422, IEEE; Lu, et al. "Preliminary Investigation of Bio-carriers Using Magnetotactic Bacteria"; Pro-

ceedings of the 28th IEEE EMBS Annual International Conference (2006); pp. 3415-3418 IEEE, and Martel "Towards MRI-Controlled Ferromagnetic and MC-1 Magnetotactic Bacterial Carriers for Targeted Therapies in Arterioleocapillary Networks Stimulated by Tumoral Angiogenesis" Proceedings of the 28th IEEE EMBS Annual International Conference (2006) pp. 3399-3402 IEEE.

[0112] One or more motive source **150** may include propelling mechanisms such as, but not limited to, rollers or wheel-like structures (see, e.g., U.S. Pat. No. 7,042,184 and U.S. Patent Application 2006/0119304; screw-like structures (see, e.g., Ikeuchi, et al. "Locomotion of Medical Micro Robot with Spiral Ribs Using Mucus" Seventh International Symposium on Micro Machine and Human Science (1996) pp. 217-222 IEEE); and/or appendages capable of walking motion (see, e.g., U.S. Pat. No. 5,574,347; Shristensen "Musclebot: Microrobot with a Heart" Technovelgy.com; pp. 1-2; (2004); located at <http://www.technovelgy.com/ct/Science-Fiction-News.asp?NewsNum=46>; and Martel "Fundamentals of high-speed piezo-actuated three-legged motion for miniature robots designed for nanometer-scale operations" pp. 1-8), and others. Appendage-like structures may intermittently engage the lumen wall and push the structural element with respect to the lumen wall with a walking-type motion, or may push against fluid within the lumen in a paddling or swimming motion. In some embodiments, the propelling mechanism may drive rotational movement of a lumen-wall-engaging structure with respect to the structural element, e.g., as in turning of a wheel or a screw element to propel the structural element through a lumen.

[0113] One or more motive source **150** may include propelling mechanisms such as, but not limited to, an inchworm-type propulsion mechanism with suction mechanisms for engaging a surface (see, e.g., Patrick, et al. "Improved Traction for a Mobile Robot Traveling on the Heart", Proceedings of the 28th IEEE EMBS Annual International Conference (2006) pp. 339-342 IEEE; Dario, et al. "A Micro Robotic System for Colonoscopy" Proceedings of the 1997 IEEE International Conference on Robotics and Automation (1997) pp. 1567-1572 IEEE; and Dongxiang, et al. "An earthworm based miniature robot for intestinal inspection" Proceedings of SPIE (2001) 4601:396-400 SPIE).

[0114] One or more motive source **150** may include propelling mechanisms such as, but not limited to, multiple lumen wall engaging structures, operating in sequence to alternately engage and disengage the lumen wall, to produce "peristaltic" motion (see, e.g., U.S. Pat. No. 6,764,441; U.S. Patent Application 2006/0004395; Mangain, et al. "Development of a Peristaltic Endoscope" IEEE International Conference on Robotics & Automation 2002; pp. 1-6; http://biorobots.cwru.edu/publications/ICRA02_Mangan_Endoscope.pdf; and Meier, et al. "Development of a compliant device for minimally invasive surgery" Proceedings of the 28th IEEE EMBS Annual International Conference (2006) pp. 331-334 IEEE).

[0115] One or more motive source **150** may include propelling mechanisms such as, but not limited to, one or more paddles, propellers, or the like, which push against fluid contained within the lumen rather than engaging the wall of the body lumen (see, e.g., U.S. Pat. No. 6,240,312; and Behkam, et al. Proceedings of the 28th IEEE EMBS Annual International Conference (2006) pp. 2421-2424 IEEE).

[0116] One or more motive source **150** may include mechanisms configured to allow affixation to a lumen wall or other interior location, either permanent or temporary. In illustrative embodiments, configurations for affixing may include, but are not limited to, one or more anchors configured to attach at least temporarily to a wall of the lumen, one or more hooks and/or claws, one or more adhesive materials and/or glues, one or more brakes to oppose the action of the propelling mechanism, one or more expanding elements, one or more suction-generating elements, and/or a shutoff for the propelling mechanism and/or for one or more power source **140**.

[0117] In some embodiments, one or more configurations for affixing one or more devices may be activated responsive to control circuitry. In some embodiments, one or more configurations for affixing one or more devices may be fixed or movable. Movable structures may include, but are not limited to, mechanical elements and/or materials that change shape or rigidity in response to temperature, electric field, magnetic field, or various other control signals. Affixation may be permanent, for extended periods, and/or temporary. As used herein, the term "extended periods" may include weeks to months to years and subsets thereof. As used herein, the term "temporary" may include seconds, to minutes, to hours, to days and subsets thereof.

[0118] One or more motive source **150** may include mechanisms configured to allow one or more device to become stationary relative to a flow of fluid through a lumen and/or an internal location. In illustrative embodiments, configurations for becoming stationary include, but are not limited to, becoming affixed to a lumen or other internal location (e.g. by one or more mechanism described above), and/or reversing the propelling mechanism. Illustrative embodiments of configurations for reversing a propelling mechanism include, but are not limited to, reverse orientation of one or more motive source **150** (e.g. oriented to provide motive force in a reverse direction, such as against the flow of fluid, for example), one or more motive source **150** configured to allow bi-directional orientation (e.g. provide motive force in two directions, optionally 180 degrees apart (in opposition)), and/or one or more motive source configured to allow motive force to be applied in variable orientations.

[0119] In one aspect, the disclosure is drawn to one or more methods for ablating one or more targets optionally at least partially based on a fluorescent response, optionally using one or more apparatus **100** and/or **500** and/or device **200**, **300** and/or **400** described herein. Although one or more methods may be presented separately herein, it is intended and envisioned that one or more methods and/or embodiments of one or more methods may be combined and/or substituted to encompass the full disclosure. In some embodiments, one or more methods may include one or more operations, and be implemented using one or more computing devices and/or systems.

[0120] In some embodiments, one or more methods of treatment include providing to a lesion electromagnetic energy selected to induce a fluorescent response from a target area; detecting the fluorescent response; identifying the target area at least partially based on an analysis of the detected fluorescent response; and providing energy to at least partially ablate the identified target area in real time. In

some embodiments, one or more methods for ablating one or more target cells include providing to a lesion electromagnetic energy selected to induce a fluorescent response from a target area; detecting the fluorescent response; identifying the target area at least partially based on an analysis of the detected fluorescent response; and providing energy to at least partially ablate the identified target area in real time.

[0121] In some embodiments, one or more methods for detecting and ablating a target area include providing an untethered device to a lumen of a subject; providing from the untethered device electromagnetic energy selected to induce an auto-fluorescent response in one or more target cells in proximity to the lumen; detecting the auto-fluorescent response using a sensor in the untethered device; identifying the target area at least partially based on an analysis of the detected auto-fluorescent response; and providing from the untethered device energy configured to at least partially ablate the identified target area. In some embodiments, one or more methods of treatment include providing an untethered device to a lumen of a subject; providing from the untethered device electromagnetic energy selected to induce an auto-fluorescent response in one or more target cells in the lumen; detecting the auto-fluorescent response using a sensor in the untethered device; identifying the target area at least partially based on an analysis of the detected auto-fluorescent response; and providing from the untethered device electromagnetic energy configured to at least partially ablate the identified target area.

[0122] In some embodiments, one or more methods for treating or ameliorating *H. pylori* infection include providing to a digestive tract of a subject an untethered ingestible mass, the untethered ingestible mass configured for non-uniform movement; and emitting electromagnetic energy from the untethered ingestible mass in a manner selected to induce photodynamic cell death in *H. pylori*. In some embodiments, one or more methods for ablating *H. pylori* include providing to a digestive tract of a subject an untethered ingestible mass, the untethered ingestible mass configured for non-uniform movement; and emitting electromagnetic energy from the untethered ingestible mass in a manner selected to induce photodynamic cell death in *H. pylori*.

[0123] In some embodiments, one or more methods for detecting and ablating a target area in a digestive tract include providing to a subject an optionally rotating untethered ingestible mass and/or optionally configured for non-uniform movement; providing from the untethered ingestible mass electromagnetic energy selected to induce an auto-fluorescent response in one or more target cells in the digestive tract; detecting the auto-fluorescent response using a sensor in the untethered device; identifying the target area at least partially based on an analysis of the detected auto-fluorescent response; and providing from the untethered device electromagnetic energy configured to at least partially ablate the identified target area. In some embodiments, one or more methods for treating a disease or disorder in a digestive tract include providing to a subject a rotating untethered ingestible mass; providing from the untethered ingestible mass electromagnetic energy selected to induce an auto-fluorescent response in one or more target cells in the digestive tract; detecting the auto-fluorescent response using a sensor in the untethered device; identifying the target area at least partially based on an analysis of the detected auto-fluorescent response; and providing from the

untethered device electromagnetic energy configured to at least partially ablate the identified target area. In some embodiments, one or more methods of treatment include providing to a subject a rotating untethered ingestible mass; providing from the untethered ingestible mass electromagnetic energy selected to induce an auto-fluorescent response in one or more target cells in the digestive tract; detecting the auto-fluorescent response using a sensor in the untethered device; identifying the target area at least partially based on an analysis of the detected auto-fluorescent response; and providing from the untethered device electromagnetic energy configured to at least partially ablate the identified target area.

[0124] In some embodiments, one or more methods for detecting and ablating one or more target cells include providing to an internal location a tethered device; providing from the tethered device electromagnetic energy selected to induce an auto-fluorescent response from the one or more target cells; detecting the auto-fluorescent response; identifying a target area at least partially based on an analysis of the detected auto-fluorescent response; and providing energy to at least partially ablate the identified target area in real time. In some embodiments, one or more methods of treatment include providing to an internal location a tethered device; providing from the tethered device electromagnetic energy selected to induce an auto-fluorescent response from one or more target cells; detecting the auto-fluorescent response; identifying a target area at least partially based on an analysis of the detected auto-fluorescent response; and providing energy to at least partially ablate the identified target area in real time.

[0125] Embodiments of one or more methods include affixing one or more devices **200**, **300**, and/or **400** to a location in a lumen and/or an interior location. As used herein, the term “affixing” may include, but is not limited to one or more processes by which the one or more devices may be held stationary in the lumen or internal location. The affixation may be temporary and/or permanent as described herein. Mechanisms by which one or more device may become affixed are known in the art and/or described herein.

[0126] Embodiments of one or more methods include moving one or more devices **200**, **300**, and/or **400** from one location to another within a lumen and/or internal location. As used herein, the term “moving” may include, but is not limited to, one or more processes by which a device may traverse a lumen and or internal location in one or more directions. Movement may be with the flow of an optional moving fluid (and/or gravity), against the flow of an optional moving fluid (and/or gravity), and or at an angle oblique to a moving flow of fluid (and/or gravity). Movement may be irrespective of the presence and/or absence of fluid and/or moving fluid. Movement may be temporary, intermittent, and/or continuous. Movement may be random and/or non-uniform. Movement may be controlled by control circuitry, either internal or external to the device. Movement may be associated with identification and/or ablation of a target. Mechanisms for moving one or more device are known in the art and/or are described herein.

[0127] In illustrative embodiments, moving an untethered device includes moving an untethered device by providing a motive force to the untethered device. As used herein, the term “motive force” may include, but is not limited to, a

mechanism that allows the untethered device to move within a lumen and/or internal location, such as for example, those described for a motive source and a power source herein. In some embodiments, a motive force is responsive to control circuitry, is remote-controlled, is programmable, and/or is feedback-controlled. In some embodiments, a motive force is powered by a battery, a capacitor, receives power from one or more external sources, and/or from one or more physiological sources. In some embodiments, a motive force is responsible for the random and or non-uniform movement of a device.

[0128] Embodiments of one or more methods include providing electromagnetic energy, optionally optical energy, to a target, target area, target cell, target tissue, lesion, incision, wound, internal location, and/or lumen, optionally selected to induce a fluorescent response. Providing electromagnetic energy optionally includes using a laser, optionally handheld, or other device to provide optical energy to a target.

[0129] Parameters associated with the selection of electromagnetic energy to induce a fluorescent response include, but are not limited to, the target, the environment associated with the target, the characteristics of the electromagnetic energy source, and/or the characteristics of the sensor.

[0130] The parameters associated with the target include, but are not limited to, the distance of the target from the electromagnetic source, the depth of the target beneath a surface (e.g. a lumen wall, an internal surface, a lesion surface), the inherent fluorescence of the target, the markers/tags used to identify the target, the size of the target, and/or the movement of the target (e.g. stationary, steady movement, variable movement, predictable movement, etc.).

[0131] The parameters associated with the environment include, but are not limited to, location (e.g. external, internal, lumen, wound, incision, etc.), milieu (e.g. fluid-filled, air-filled, blood, digestive contents, etc.), movement (e.g. stationary, steady movement, intermittent movement, predictable movement, etc.), physiologic parameters (e.g. pH, temperature, etc.), and/or non-target fluorescence (e.g. background fluorescence, non-specific fluorescence, intrinsic non-target fluorescence, etc.).

[0132] The parameters associated with the characteristics of the electromagnetic energy source include, but are not limited to, the wavelengths available for selection (e.g. single, two-photon, multiple, extended-spectrum, etc.), the strength of the emitted electromagnetic energy (e.g. limitations on distance and/or depth, etc.), the type of output (e.g. pulsed, two-photon, etc.), directionality (e.g. limited, variable, varied, etc.), and/or spatial parameters (e.g. limited, focused, collimated, etc.).

[0133] The parameters associated with the characteristics of the sensor include, but are not limited to, the detection limits associated with wavelength (e.g. single, two-photon, multiple, extended-spectrum, etc.), signal strength (e.g. sensitivity of detection, level above background, etc.), and/or time (e.g. detects cumulative readings over time, detects readings at certain time intervals, or at a certain time post excitation, etc.).

[0134] Embodiments of one or more methods include selecting the electromagnetic energy, optionally optical energy, to induce the fluorescent response. Methods for

selecting include, but are not limited, manually, remotely, automatically, programmably, wirelessly, and/or using control circuitry. Manually selecting includes, but is not limited to, manually operating one or mechanism (e.g. a switch, dial, button, etc.) on one or more apparatus **100** and/or **500**, and/or device **200**, **300**, and/or **400**, that controls the emitted wavelength from one or more electromagnetic energy source. Remotely selecting includes, but is not limited to, optionally wirelessly interacting with circuitry on one or more apparatus **100** and/or **500**, and/or device **200**, **300**, and/or **400** that controls the wavelength emitted from one or more electromagnetic energy source. Programmably selecting includes, but is not limited to, optionally using control circuitry, optionally part of one or more apparatus **100** and/or **500**, and/or device **200**, **300**, and/or **400** (e.g. internal and/or external), programmed, optionally manually, remotely, and/or wirelessly, to select the wavelength emitted from one or more electromagnetic energy source. Methods for programming control circuitry are well-known to one of skill in the art, and some applicable control circuitry is described herein.

[0135] Embodiments of one or more methods include monitoring the electromagnetic energy selected to induce a fluorescent response, optionally an auto-fluorescent response, optionally a target fluorescent response, monitoring the energy selected to ablate the target, optionally electromagnetic energy, optionally particle beam energy, and/or monitoring the targeting electromagnetic energy, optionally visual light. Methods of monitoring electromagnetic energy and/or particle beam energy are known in the art and/or described herein. Methods include, but are not limited to, using sensors able to detect one or more characteristics of the energy.

[0136] Embodiments of one or more methods include detecting a fluorescent response. Methods of detecting a fluorescent response include, but are not limited to, detecting a fluorescent response using one or more sensors, detectors, and/or monitors. Sensors, detectors, and/or monitors appropriate for detection and/or monitoring of the fluorescent response are known in the art and/or described herein. As used herein, the term “detecting” may include any process by which one or more characteristics of a fluorescent response may be measured and/or quantified.

[0137] Embodiments of one or more methods include identifying a target for ablation (e.g. target area, target cells, and/or target tissues). As used herein, the term “identifying a target” may include, but is not limited to, processes including selecting a target and/or determining a target. One or more methods for identifying a target for ablation optionally include analyzing a fluorescent response and/or other information, optionally using control circuitry, optionally in real time.

[0138] Analyzing a fluorescent response to at least partially identify a target for ablation may include, but is not limited to, evaluating a fluorescent response at least partially in reference to baseline fluorescence, background fluorescence, expected fluorescence, normal fluorescence, reference fluorescence, non-specific fluorescence, and/or intrinsic non-target fluorescence, etc. Analyzing a fluorescent response may include, but is not limited to, subtractively determining a target fluorescent response (e.g. subtracting the non-target fluorescence from the total fluorescence to

determine the target fluorescence). Analyzing a fluorescent response may include, but is not limited to, evaluating a fluorescent response at least partially based on detection at one or more wavelengths (e.g. single, multiple, extended-spectrum, etc.), based on time (e.g. one or more times, time intervals, and/or over time, etc.), based on direction (e.g. of origination of the emission, etc.), based on strength, and/or based on distance (e.g. of origination of emission from a sensor). In illustrative embodiments, analyzing a fluorescent response may include, but is not limited to, identifying “clumps” and/or “groups” of autofluorescent cells that in another context might be considered “normal”, but that are not normally grouped and so may be a target for ablation.

[0139] In illustrative embodiments, an analyzed target fluorescent response is used to determine the direction from which the response originated in order to provide ablation energy to the location and/or general area. In illustrative embodiments, an analyzed target fluorescent response is used to determine the coordinates from which the response originated in order to provide ablation energy to the location and/or general area.

[0140] As used herein, the term “location” may include, but is not limited to, one or more of a direction, an area, a depth, a site, or a size, etc. A location may be defined by spatial coordinates and/or temporal coordinates. A location may be defined as precisely as the cellular level, for example, or as broadly as a general area, or a general direction. Methods of determining a location based on the detection of a fluorescent response are known in the art and/or described herein. In illustrative embodiments, a target location may be the cancerous and/or pre-cancerous cells remaining in a surgical margin. In illustrative embodiments, a target location may be the microbial cell contamination remaining in a wound following a sterile wash. In illustrative embodiments, a target location may be the lumen of a blood vessel following detection of a target fluorescent response. In illustrative embodiments, a target location may be the lumen of the digestive tract in a area with an acidic pH.

[0141] Analyzing other information to at least partially identify a target for ablation may include, but is not limited to, analyzing information optionally provided by one or more sensors (e.g. intrinsic and/or extrinsic to one or more device and/or apparatus) and/or provided by one or more external sources (e.g. remotely and/or wirelessly, etc.). Analyzing information optionally provided by one or more sensors may include analyzing information including, but not limited to, environmental information such as, but not limited to, pH, temperature, pressure, chemistry, physiological measurements, dietary measurements, biological measurements, etc. In illustrative embodiments, identifying a target fluorescent response is at least partially based on identifying the pH of the environment, optionally detecting an acidic pH. Analyzing information optionally provided by one or more external sources may include analyzing information including, but not limited to, environmental information and/or medical and/or veterinary professional information.

[0142] Analyzing a fluorescent response to at least partially identify a target for ablation may include, but is not limited to, evaluating a fluorescent response in real time. As used herein, the term “in real time” may include, but is not limited to, immediate, rapid, not requiring operator inter-

vention, automatic, and/or programmed. In real time may include, but is not limited to, measurements in femtoseconds, picoseconds, nanoseconds, milliseconds, as well as longer, and optionally shorter, time intervals. In illustrative embodiments, analysis in real time is sufficiently rapid such that the target and the device have not moved and/or changed positions/locations significantly with respect to each other. In illustrative embodiments, a fluorescent response is detected and analyzed, and a target is identified without operator intervention and the target ablation information is provided to an energy source.

[0143] Embodiments of one or more methods include providing energy to at least partially ablate a target. One or more methods include providing energy to at least partially ablate a target in real time. As used herein the term “ablation or ablate” may include, but is not limited to, processes including destroying, modifying, removing, and/or eliminating, in part or in whole, a target and/or a material of interest. As used herein, ablation may include the process of removing material, optionally from a surface, by irradiating it, optionally with a laser beam. At low laser flux, the material is heated by the absorbed laser energy and evaporates or sublimates. At high laser flux, the material is typically converted to a plasma. Ablation may include the process of removing material with a pulsed laser, or a continuous wave laser.

[0144] Energy for ablation may include, but is not limited to, electromagnetic energy, X-ray energy, and particle beam energy. Electromagnetic energy such as light may cause, for example, a photoreaction, molecular bond breakage, heating, or other appropriate effect. Electromagnetic energy sources may include, but are not limited to, light sources such as light emitting diodes and laser diodes, or sources of other frequencies of electromagnetic energy, radio waves, microwaves, ultraviolet rays, infra-red rays, optical rays, terahertz beams, and the like.

[0145] As used herein, the term “at least partially ablate” may include partially and/or completely ablating a target. As used herein, the term “completely ablate” may include ablation of a target up to the applicable limits of detection (e.g. no longer detectable by the sensors used to detect the fluorescent response, no longer detectable over background, and/or no longer statistically significant). As used herein the term “partially ablate” may include ablation less than complete ablation, but where at least some detectable ablation occurs. At least some detection ablation includes, but is not limited to, ablation detectable by the sensors used to detect the fluorescent response, statistically significant ablation, detection by external sensors, and/or detection by inference from other measurements and/or sensor readouts.

[0146] Embodiments of one or more methods include providing targeting electromagnetic energy to a lesion, a lumen, an internal location, etc. methods for providing targeting electromagnetic energy are known in the art, and/or described herein. Targeting electromagnetic energy is optionally optical energy, optionally visible to the human eye. Targeting electromagnetic energy is optionally alignable with electromagnetic energy emitted to induce a fluorescent response and/or with energy emitted to at least partially ablate a target. In illustrative embodiments, targeting electromagnetic energy is aligned with the output from one or more energy sources as a visual aid to a medical and/or veterinary professional during treatment of a subject.

EXAMPLES

[0147] The following Examples are provided to illustrate, not to limit, aspects of the present invention. Materials and reagents described in the Examples are commercially available unless otherwise specified.

Example 1

Detection and Ablation of Pathogens Prior to Closing a Surgical Incision

[0148] A surgical incision is screened with a device that detects and ablates pathogens within the open lesion prior to closing to prevent postoperative infection. The device emits electromagnetic energy at wavelengths sufficient to induce autofluorescence of pathogens within the incision. The device detects the autofluorescence associated with the pathogens, and in real time automatically delivers energy sufficient to at least partially inactivate or ablate the pathogens. Optionally, the device detects the autofluorescence, collects and processes the data, and at the discretion of the surgeon or other medical practitioner (or veterinarian), a trigger mechanism, for example, is used to deliver energy sufficient to at least partially inactivate or ablate the pathogens at the coordinates associated with the autofluorescence. The device may be handheld, for example, and either self-contained or connected wirelessly or by wire to optionally a power supply, energy sources, control circuitry, and/or monitor. Alternatively, the device may be a fixed component of the surgical theater.

[0149] A pathogen or pathogens may be detected at the site of incision based on autofluorescence induced, for example, by electromagnetic energy. Naturally occurring autofluorescence in bacteria, for example, is derived from biomolecules containing fluorophores, such as porphyrins, amino acids tryptophan, tyrosine, and phenylalanine, and the coenzymes NADP, NADPH, and flavins (Koenig, et al. (1994) *J. Fluoresc.* 4:17-40; Kim, et al. (2004) *IEEE/EMB Magazine* January/February 122-129). The excitation maxima of these biomolecules lie in the range of 250-450 nm (spanning the ultraviolet/visible (UV/VIS) spectral range), whereas their emission maxima lie in the range of 280-540 (spanning the UV/VIS spectral range; Ammor (2007) *J. Fluoresc.* published on-line ahead of publication).

[0150] For example, two clinically important bacteria, *Enterococcus faecalis*, and *Staphylococcus aureus*, may be differentiated based on their respective autofluorescence in response to excitation spectra of 330-510 nm and emission spectra of 410-430 nm (Ammor (2007) *J. Fluoresc.* published on-line ahead of publication). Similarly, *Streptococcus pneumoniae*, *Moraxella catarrhalis*, and *Haemophilus influenzae* may be detected using fluorescence spectroscopy at excitation wavelengths of 250 and 550 nm and emission wavelengths of 265 and 700 nm (Ammor (2007) *J. Fluoresc.* published on-line ahead of publication). Bacteria associated with community acquired pneumonia, *Legionella anisa* and *Legionella dumoffii*, autofluoresce blue-white when exposed to long-wave (365-nm) UV light (Thacker, et al. (1990) *J. Clin. Microbiol.* 28:122-123). *Bacillus* spores will autofluoresce when excited by UV irradiation at a wavelength of 352 nm (Laflamme, et al. (2006) *J. Fluoresc.* 16:733-737). *Clostridium sporogenes*, *Pseudomonas aeruginosa*, *Pseudomonas fluorescens*, *Kocuria rhizophila*, *Bacteroides*

vulgatis, *Serratia marcescens*, and *Burkholderia cepacia* emit yellow-green fluorescent signal when illuminated with blue light (Sage, et al. (2006) *American Biotechnology Laboratory* 24:20-23).

[0151] Autofluorescence of endogenous porphyrins may also be used to detect bacteria. A number of bacteria produce protoporphyrins, including *Propionibacterium acnes*, *Bacillus thuringiensis*, *Staphylococcus aureus*, and some strains of *Clostridium*, *Bifidobacterium*, and *Actinomyces* (Koenig, et al. (1994) *J. Fluoresc.* 4:17-40). Bacteria may also be detected using fluorescence lifetimes measured at 430, 487, and 514 nm after selective excitation at 340, 405, and 430 nm (Bouchard, et al. (2006) *J. Biomed. Opt.* 11:014011, 1-7).

[0152] Autofluorescence may also be used to detect members of the fungi family. For example, *Candida albicans* irradiated with electromagnetic energy at wavelengths of 465-495 nm autofluoresces at an emission wavelength of 515-555 nm (Mateus, et al. (2004) *Antimicrob. Agents and Chemother.* (2004) 48:3358-3336; Graham (1983) *Am. J. Clin. Pathol.* 79:231-234). Similarly, *Aspergillus niger* and *Aspergillus versicolor* may be detected using autofluorescence in response to excitation at 450-490 nm and emission at 560 nm (Sage, et al. (2006) *American Biotechnology Laboratory* 24:20-23; Graham (1983) *Am. J. Clin. Pathol.* 79:231-234).

[0153] A pathogen or pathogens at the site of incision may be inactivated or killed by energy emitted from a device in response to detection of the pathogen by autofluorescence using the same device. Many pathogens are inactivated or killed by UV germicidal irradiation (Anderson, et al. (2000) *IEEE Transactions on Plasma Science* 28:83-88; Hancock, et al. (2004) *IEEE Transactions on Plasma Science* 32:2026-2031). UV light ranges from UVA (400-315 nm), also called long wave or 'blacklight'; UVB (315-280 nm), also called medium wave; and UVC (<280 nm), also called short wave or 'germicidal'."

[0154] Optionally, a wavelength may be used that completely or partially inactivates pathogens but limits damage to surrounding tissue. For example, a wavelength of 630 nm partially inhibits growth of *Pseudomonas aeruginosa* and *Escherichia coli* (Nussbaum, et al. (2002) *J. Clin. Laser Med. Surg.* 20:325-333). Similarly, a number of oral bacteria, including *Acinobacillus actinomycetemcomitans*, *Fusobacterium nucleatum*, *Porphyromonas gingivalis*, *Pneovotella intermedia*, and *Streptococcus sanguis*, may be partially inactivated using a diode 665 laser at 100 mW for 30 s (energy density 10.6 J/cm²) or 60 s (energy density 21.2 J/cm²) at a distance of 5 mm (Chan, et al. (2003) *Lasers Surg. Med.* 18:51-55).

[0155] Inactivation of bacteria by a diode 665 laser may be enhanced, for example, by pre-staining the bacteria with methylene blue (Chan, et al. (2003) *Lasers Surg. Med.* 18:51-55). Similarly, oral bacteria may be inactivated using a He-Ne laser at 30 mW for 30 s (energy density 3.2 J/cm²) or 60 s (energy density 6.4 J/cm²) in combination with methylene blue (Chan, et al. (2003) *Lasers Surg. Med.* 18:51-55).

[0156] Alternatively, a pathogen or pathogens may be inactivated or killed at the incision site with a form of laser thermal ablation using, for example, a CO₂ or Nd:YAG laser

(Bartels, et al. SPIE Vol 2395:602-606). For example, *Staphylococcus aureus* may be partially inactivated or killed using high-power Nd:YAG laser radiation between 50 and 300 W with laser pulse frequencies of 5 to 30 Hz and pulse energies from 2 to 30 J, resulting in a range of energy densities from 800 to 270 J/cm² (Yeo, et al. (1998) Pure Appl. Opt. 7:643-655). *Escherichia coli* 0157:H7, for example, is extremely sensitive to heat with a maximum tolerance of approximately 35 degrees centigrade (U.S. Pat. No. 6,030,653).

[0157] Pathogens may be inactivated or killed using X-ray and gamma electromagnetic energy. For example, *Escherichia coli* 0157:H7, *Salmonella*, and *Campylobacter jejuni* may be at least partially inactivated or killed using cobalt-60 gamma radiation at doses of 0.5 to 3 kGy (Clavero, et al. (1994) Applied Environ. Microbiol. 60:2069-2075).

[0158] Alternatively, pathogens may be inactivated or killed using a form of particle beam irradiation. For example, *Salmonella*, *Yersinia*, and *Campylobacter* may be at least partially ablated using accelerated electrons with doses of irradiation ranging from 1-3 kGy (Sarjeant, et al. (2005) Poult. Sci. 84:955-958). Similarly, *Bacillus* endospores may be at least partially ablated using electron beam irradiation with doses ranging from 5 to 40 kGy (Helfinstine, et al. (2005) Applied Environ. Microbiol. 71:7029-7032).

[0159] Viruses may be inactivated on a surface using UV irradiation (Tseng & Li, (2007) J. Occup. Environ. Hyg. 4:400-405). Fungi, for example *Aspergillus flavus* and *Aspergillus fumigatus*, may also be inactivated using UV germicidal irradiation at 12-98 mJ/cm² (Green, et al. (2004) Can. J. Microbiol. 50:221-224).

[0160] Alternatively, energy may be used that disrupts the function of heme iron porphyrins associated with iron uptake and utilization, inactivating iron dependent bacteria such as *Escherichia coli* and *Salmonella* (U.S. Pat. No. 6,030,653). Pathogens may be inactivated by irradiating the surface with visible and near infrared light having wavelengths of approximately 465 nm, 600 nm, and 950 nm, respectively.

[0161] In some instances, the entirety of the affected tissue may be irradiated to at least partially inactivate or kill pathogens. Alternatively, focused energy may be directed only to those sites emitting pathogen-associated autofluorescence or fluorescence. A pathogen or pathogens at the site of incision may be inactivated or killed by energy emitted from a device in either the presence or absence of prophylactic antibiotics (Dellinger, et al. (1994) Clin. Infect. Dis. 18:422-427).

[0162] There are a number of microbial pathogens of concern during surgical treatment that may lead to difficult to treat nosocomial or hospital acquired infection, including methicillin-resistant *Staphylococcus aureus* (MRSA), *Staphylococcus epidermidis*, *Streptococcus pyogenes*, *Pseudomonas aeruginosa*, vancomycin-resistant Enterococci (VRE), extended spectrum β -lactamase-producing bacteria (ESBL), multi-drug resistance in *Mycobacterium tuberculosis* (MDRTB) strains as well as multi-drug resistant Gram-negative bacteria (Lichtenstern, et al. (2007) Dig. Surg. 24:11; NIAID (National Institute of Allergy and Infectious Disease) Profile Fiscal Year 2005, Selected Scientific Areas of Research, Antimicrobial Resistance, pages 52-55).

[0163] The Gram-positive bacteria *Staphylococcus aureus* is a common cause of superficial skin infections such as boils, furuncles, styes, impetigo. *S. aureus* is also a major cause of nosocomial and community-acquired infections, particularly in individuals debilitated by chronic illness, traumatic injury, burns or immunosuppression, as well as a common cause of postoperative infection. The infection may produce abscesses at the stitches or may cause extensive destruction of the incision site. Postoperative infections caused by *S. aureus* may appear a few days to several weeks after an operation but may develop more slowly in an individual taking antibiotics. Upon bloodstream dissemination or by continuous spread, *S. aureus* can readily survive in various deep tissues and can cause, among others, abscess formation, osteomyelitis, endocarditis, and sepsis. *S. aureus* may be detected by autofluorescence at the incision site using a device emitting electromagnetic energy at a wavelength, for example, of 488 nm (Hilton (1998) SPIE 3491:1174-1178). Optionally, *S. aureus* may be distinguished from, for example, *Escherichia coli* and *Enterococcus faecalis* based on emission spectra induced by excitations at 410-430 nm (Giana, et al. (2003) J. Fluoresc. 13:489-493; Ammor (2007) J. Fluoresc. published on-line ahead of publication).

[0164] *S. aureus* associated with the incision site may be killed or inactivated by irradiating the tissue with energy, for example, at a short UV "germicidal" wavelength as described above. Alternatively, *S. aureus* may be inactivated using a blue light with a wavelength, for example, of 405 nm at doses ranging from 1-20 Jcm⁻² (Guffey, et al. (2006) Photomed. Laser Surg. 24:680-683). Optionally, a blue light may be combined, for example, with an infrared light at a wavelength of 880 nm to promote tissue repair in combination with bacterial ablation (Guffey, et al. (2006) Photomed. Laser Surg. 24:680-683). In some instances, the entirety of the effected tissue may be irradiated. Alternatively, focused energy may be directed only to those sites emitting *S. aureus*-associated autofluorescence.

[0165] The Gram-negative bacteria *Pseudomonas aeruginosa* is another common cause of nosocomial infections, particularly in patients hospitalized with cancer, cystic fibrosis, and burns, and has a mortality rate of 50%. Other infections caused by *Pseudomonas* species include endocarditis, pneumonia, and infections of the urinary tract, central nervous system, wounds, eyes, ears, skin, and musculoskeletal system. *P. aeruginosa* is an opportunistic and ubiquitous pathogen with limited tissue penetration on its own, gaining entry to the host, for example, through burns, wounds, intravenous and urinary catheterization, and surgical procedures. *P. aeruginosa* may be detected by autofluorescence at the incision site using a device emitting electromagnetic energy at a wavelength, for example, of 488 nm (Hilton (1998) SPIE 3491:1174-1178). *P. aeruginosa* contains a pigment called pyocyanin which appears blue in visible light and may also be used for detection.

[0166] *P. aeruginosa* may be killed using a blue light with a wavelength, for example, of 405 nm at doses ranging from 1-20 Jcm⁻² (Guffey, et al. (2006) Photomed. Laser Surg. 24:680-683). Alternatively, irradiation using a wavelength, for example, of 630 nm at 1-20 Jcm⁻² may partially inactivate *P. aeruginosa* (Nussbaum, et al. (2002) J. Clin. Laser Med. Surg. 20:325-333).

Example 2

Detection and Ablation of Pathogens Prior to Closing and/or Bandaging a Wound

[0167] A wound may be screened with a handheld device that detects and ablates pathogens within the open lesion prior to closing (e.g. suturing) and/or bandaging to prevent possible microbial infection. The device emits electromagnetic energy at wavelengths sufficient to induce autofluorescence of pathogens within the wound. Alternatively, the device emits electromagnetic energy at wavelengths sufficient to induce fluorescence of reagents applied to the wound to selectively detect pathogens, such as, for example, a chemical dye or an antibody or aptamer conjugated to a fluorescent tag. Pathogens may include bacteria, fungi and/or viruses. The handheld device detects the autofluorescence or reagent-induced fluorescence associated with the pathogens and in real time automatically delivers energy sufficient to ablate or kill the pathogens. Optionally, the handheld device detects the autofluorescence, collects and processes the data, and at the discretion of the user, a trigger mechanism, for example, is used to deliver energy sufficient to at least partially inactivate or ablate the pathogens at the coordinates associated with the autofluorescence.

[0168] Pathogens commonly associated with wound infections include the Gram-positive cocci *Streptococcus pyogenes*, *Enterococcus faecalis*, and *Staphylococcus aureus*, the Gram-negative rods *Pseudomonas aeruginosa*, *Enterobacter* species, *Escherichia coli*, *Klebsiella* species, and *Proteus* species, the anaerobes *Bacteroides* and *Clostridium*, and the fungi *Candida* and *Aspergillus* (World Wide Wounds January 2004). Additional microbes of concern include *Burcella*, which infects cows, sheep, and goats, and can be transmitted through secretion and excretion to open wounds, *Bartonella henselae*, which is associated with cats and can cause "cat scratch fever", and *Clostridium tetani* which survives for years in soil and animal feces and can cause infection in both superficial wounds and deep in contaminated wounds of individuals not immunized against tetanus (Park, et al. (2001) J. Bacteriol. 183:5751-5755). In addition, *Vibrio vulnificus* is an emerging human pathogen which is found primarily in sea water and can be transmitted into open wounds and cause infection (Oliver, et al. (1986) Applied Environmental Microbiology 52:1209-1211). Among healthy individuals, ingestion of *V. vulnificus* can cause vomiting, diarrhea, and abdominal pain. In immunocompromised persons, particularly those with chronic liver disease, *V. vulnificus* can invade the bloodstream through a wound, causing primary septicemia and a 50% mortality rate.

[0169] A pathogen or pathogens may be detected at the wound site based on autofluorescence induced by electromagnetic energy at specific or multiple wavelengths, as described herein. *Bartonella henselae*, for example, has weak autofluorescence at an excitation wavelength of 485 nm and emission wavelength of 538 nm (Park, et al. (2001) J. Bacteriol. 183:5751-5755). Some strains of *V. vulnificus* exhibit bioluminescence with maximal light emission at 483 nm (Oliver, et al. (1986) Applied Environmental Microbiology 52:1209-1211).

[0170] Alternatively, pathogens may be detected at the wound site based on addition of an agent or agents that

fluoresces and binds selectively to the pathogen, allowing for detection and subsequent ablation of the pathogen. For example, a fluorescent stain such as BacLight™ Green or BacLight™ Red bacterial stain (absorption/emission: 480/516 and 581/644, respectively) may be used to detect, for example, *Staphylococcus aureus* and *Escherichia coli* (Invitrogen, Carlsbad, Calif.). & aureus may also be detected at the wound site based on binding of immunoglobulins to the bacterial cell wall. Protein A on the surface of *S. aureus* readily binds the IgG class of immunoglobulins (Hjelm, et al. (1972) FEBS Lett. 28:73-76). To detect *S. aureus*, the incision site may be briefly sprayed with a sterile saline solution containing, for example, an IgG antibody conjugated to a fluorescent tag, for example FITC, Rhodamine, or Cy3, and rinsed. The fluorescence is detected by the handheld device. In response, energy is emitted specifically to the fluorescing site and the bacteria are killed.

[0171] Alternatively, pathogens may be detected at the wound site using fluorescently labeled antibodies. For example, *Streptococcus pyogenes*, one of the main pathogens associated with necrotizing fasciitis, may be detected using antibodies from commercial sources (e.g. AbD SEROTEC, Oxford, UK; Affinity BioReagents, Golden, Colo.; GeneTex, Inc. San Antonio, Tex.). Antibodies against *S. pyogenes* may be conjugated, for example, with a fluorescent tag such as the Alexa Fluors, FITC, Oregon Green, Texas Red, Rhodamine, Pacific Blue, Pacific Orange, Cy3, or Cy5 using labeling kits available from commercial sources (e.g. Invitrogen, Carlsbad, Calif.; Pierce, Rockford, Ill.). Alternatively, antibodies to *S. pyogenes* may be labeled with quantum dot nanocrystals using labeling kits from commercial sources (e.g. Invitrogen, Carlsbad, Calif.). Similarly, *P. aeruginosa* and *S. aureus*, for example, may be detected at the wound site using commercially available antibodies tagged with a fluorophore (e.g. Accurate Chemical & Scientific Co., Westbury, N.Y.; AbD SEROTEC, Oxford, UK; Cell Sciences Inc., Canton, Mass.).

[0172] The fluorescing bacterial stain, immunoglobulin, antibody, or aptamer may be administered to the wound in a sterile solution, rinsed and the wound subsequently screened with the handheld device. The handheld device may be placed in close proximity to a wound and emits electromagnetic energy at wavelengths ranging, for example, from 300 to 700 nm to excite autofluorescence of endogenous molecules or fluorescence of a probe associated with the pathogen. The resulting fluorescence is detected by the handheld device which subsequently emits energy sufficient to at least partially inactivate or ablate the pathogen. In some instances, the entirety of the effected tissue may be irradiated. Alternatively, focused energy may be directed only to those sites emitting pathogen-associated autofluorescence or fluorescence.

[0173] Autofluorescence may also be used to detect members of the fungi family. For example, *Candida albicans* irradiated with electromagnetic energy at wavelengths of 465-495 nm autofluoresces at an emission wavelength of 515-555 nm (Mateus, et al. (2004) Antimicrobial Agents and Chemotherapy 48:3358-3336; Graham (1983) Am. J. Clin. Pathol. 79:231-234). Similarly, *Aspergillus niger* and *Aspergillus versicolor* may be detected using autofluorescence in response to excitation at 450-490 nm and emission at 560 nm (Sage, et al. (2006) American Biotechnology Laboratory 24:20-23; Graham (1983) Am. J. Clin. Pathol.

79:231-234). Alternatively, fungi may be detected in a wound using the non-selective dye, Congo Red, which fluoresces at excitation maxima of 470 and 546 nm when irradiated with electromagnetic energy at wavelengths ranging from 450-560 nm (Slifkin, et al. (1988) J. Clin. Microbiol. 26:827-830).

[0174] A pathogen or pathogens at the wound site may be inactivated or killed by energy emitted from a handheld device in response to detection of the pathogen or pathogens by autofluorescence using the same handheld device. Energy in the form of UV irradiation may be used to at least partially inactivate or kill a pathogen or pathogens as described herein. Alternatively, a pathogen, for example *Escherichia coli*, may be at least partially inactivated or killed at a wound site in response to fluence doses ranging from 130-260 J/cm² using a 810 nm diode laser (Jawhara, et al (2006) Lasers Med. Sci. 21:153-159). Alternatively, a pathogen or pathogens may be at least partially inactivated or killed at the wound site with a form of laser thermal ablation using energy emitted, for example, from a CO₂ (10,600 nm) or a Nd:YAG (1064 nm) laser (Bartels, et al. SPIE Vol 2395:602-606). For example, *Staphylococcus epidermidis*, a common skin bacteria, may be killed using pulsed radiation from a Nd:YAG laser with an exposure of 1000-2000 J/cm² (Gronqvist, et al. (2000) Lasers Surg. Med. 27:336-340). Alternatively, a pathogen at a wound site may be at least partially inactivated or killed using electron beam or x-ray or gamma irradiation as described herein.

[0175] Optionally, energy emitted from the handheld device may be combined with a photosensitive agent applied directly to the wound (Maisch (2007) Lasers Med. Sci. 22:83-91; Jori, et al. (2006) Lasers Surg. Med. 38:468-481). As such, the photosensitive agent may be administered to the wound in a sterile solution, allowed to incubate for a certain interval, for example 1-30 minutes, rinsed and subsequently screened with the handheld device. The wound may be irradiated by the handheld device first with wavelengths sufficient to detect the photosensitive agent and second with energy sufficient to at least partially inactivate or kill the pathogens. For example, *Staphylococcus aureus* and *Pseudomonas aeruginosa* may be inactivated using either a 0.95-mW helium-neon laser (632 nm) or a 5-mW indium-gallium-aluminum-phosphate laser (670 nm) with exposure doses ranging from 0.1 to 10.0 J/cm² in combination with the bacterial sensitizing agent, toluidine blue 0, (DeSimone, et al. (1999) Phys. Ther. 79:839-846). Alternatively, a diode laser with an emission wavelength, for example, of 808 nm may be used in combination with a topically applied fluorescing dye, for example, indocyanine green (ICG), to inactivate a pathogen or pathogens (Bartels, et al. SPIE Vol 2395:602-606). ICG may be used to concentrate the diode laser energy to very specific "stained" areas with minimal damage to surrounding tissue. Optionally, a polycationic photosensitizer conjugated between, for example, poly-L-lysine and chlorin_{e6}, may be topically applied to a wound and subsequently irradiated with a diode laser at 665 nm at doses ranging from, for example, 40-160 J/cm² to kill bacteria (Hamblin, et al. (2002) Photochem. Photobiol. 75:51-57). Optionally, pathogens in a wound site, such as, for example, *Staphylococcus aureus* and *Staphylococcus epidermidis*, may be at least partially inactivated using energy from, for example, an argon-ion pumped dye laser (wavelength of 630 nm with total light dose of 180 J/cm²) in combination with 5-aminolevulinic acid or Photofrin

(Karrer, et al (1999) Lasers Med. Sci. 14:54-61; Nitzan, et al (1999) Lasers Med. Sci. 14:269-277).

Example 3

Detection and Ablation of Pathogens on Oral or Skin Surfaces

[0176] An oral cavity or surface of the skin may be screened with a device that detects and ablates pathogens associated with plaque and acne, respectively. The device emits electromagnetic energy at wavelengths sufficient to induce autofluorescence of pathogens on the surface. Alternatively, the device emits electromagnetic energy at wavelengths sufficient to cause fluorescence of reagents added to the surface to selectively detect pathogens, such as, for example, a chemical dye or an antibody or aptamer conjugated to a fluorescent tag. Pathogens may include bacteria, fungi and/or viruses. The device detects the autofluorescence or reagent-induced fluorescence associated with the pathogens and in real time automatically delivers energy sufficient to ablate or kill the pathogens. Optionally, the device detects the autofluorescence, collects and processes the data, and at the discretion of the physician or other medical practitioner, a trigger mechanism, for example, is used to deliver energy sufficient to at least partially inactivate or ablate the pathogens at the coordinates associated with the autofluorescence. The device may be handheld, for example, and either self-contained or connected wirelessly or by wire to optionally a power supply, energy sources, control circuitry, and/or monitor. Alternatively, the device may be a fixed component of, for example, a dentist's or doctor's office.

[0177] A device emitting energy may be used to detect and ablate the pathogens associated with dental plaque. For example, pathogens associated with caries and dental plaques, including *Actinomyces odontolyticus*, *Prevotella intermedia*, *Porphyromonas gingivalis*, *Peptostreptococcus*, *Candida albicans*, and *Corynebacterium*, all autofluoresce in response to violet-blue light at a wavelength of 405 nm (van der Veen, et al. (2006) Caries Res. 40:542-545; Koenig, et al. (1994) J. Fluoresc. 4:17-40). Similarly, healthy dental tissue may be distinguished from carious lesions based on the autofluorescence of the associated pathogens (Koenig, et al. (1994) J. Fluoresc. 4:17-40). For example, healthy dental tissue irradiated with an excitation wavelength, for example, of 405 nm may exhibit a broad emission spectra in the short-wavelength portion of the visible spectrum while fluorescence spectra from a carious lesion may have a maxima in the red spectral region with a main band at 635 nm, for example (Koenig, et al. (1994) J. Fluoresc. 4:17-40). Once the autofluorescence is detected, energy emitted from the device may be used to at least partially inactivate or kill the fluorescing bacteria in real time using the methods and/or devices described herein.

[0178] A device emitting energy may be used to detect and ablate the pathogens associated with acne vulgaris. For example, the Gram-positive bacteria *Propionibacterium acnes*, which are involved in the pathogenesis of acne vulgaris, may be detected on the surface of the skin using autofluorescence (Koenig, et al. (1994) J. Fluoresc. 4:17-40; Shalita, et al (2001) SPIE Vol. 4244, p. 61-73). A laser emitting radiation at 407 nm, for example, may be used to detect fluorescent spots in the nasal area and in pimples of

acne patients. The spots may differ in color, with their spectrum consisting of three main peaks, at about 580-600, 620, and 640 nm, and may be associated with autofluorescence induced by endogenous porphyrins such as protoporphyrin and coproporphyrin (Koenig, et al. (1994) *J. Fluoresc.* 4:17-40). Once the autofluorescence is detected, energy emitted from the device, for example, UV radiation, may be used to at least partially inactivate or kill the fluorescing bacteria in real time using the methods described herein. Alternatively, electromagnetic energy emitted from the device in the violet-blue range (407-420 nm) may be used to at least partially inactivate or kill pathogens associated with acne vulgaris by activating the endogenous porphyrins and causing photo-destructive ablation of the bacteria (Shalita, et al (2001) *SPIE Vol. 4244*, p. 61-73). For example, patients with acne vulgaris may be treated with a 400w UV-free, enhanced blue (407-420 nm) metal halide lamp producing, for example, 90 mW/cm² homogeneous illumination (Shalita, et al (2001) *SPIE Vol. 4244*, p. 61-73).

[0179] Alternatively, a pathogen in the oral cavity or on the surface of the skin may be at least partially inactivated or killed using electron beam or x-ray or gamma irradiation as described herein.

Example 4

Detection and Ablation of Cancer and Cancer Margins

[0180] Tissue may be screened with a device that detects and ablates cancerous cells optionally in real time. The device emits electromagnetic energy at wavelengths to induce autofluorescence selected to differentiate between normal and cancerous cells. Alternatively, the device emits electromagnetic energy at wavelengths sufficient to cause fluorescence of reagents added to the tissue to selectively detect cancerous cells, such as, for example, a photosensitizer, a chemical dye, or an antibody or aptamer conjugated to a fluorescent tag. Autofluorescence or reagent-induced fluorescence associated with cancerous cells may be used to detect cancers and to aide in surgical intervention. In addition, autofluorescence or reagent-induced fluorescence associated with cancerous cells may be used to aide a medical practitioner in defining the margins of a solid tumor to ensure thorough excision of the lesion.

[0181] The device detects the autofluorescence or reagent-induced fluorescence associated with the cancerous cells and in real time delivers energy sufficient to at least partially inactivate or ablate the cancerous cells. Optionally, the device detects the autofluorescence, collects and processes the data, and at the discretion of the surgeon or other medical (or veterinary) practitioner, a trigger mechanism, for example, is used to deliver energy sufficient to at least partially inactivate or ablate the cancerous cells at the coordinates associated with the autofluorescence. The device may be handheld, for example, and either self-contained or connected wirelessly or by wire to optionally a power supply, energy sources, control circuitry, and/or monitor. Alternatively, the device may be a fixed component of a surgical theater, doctor's office, or other venue for patient treatment.

[0182] Electromagnetic energy emitted from a device may be used to induce autofluorescence of a tissue such as, for

example, the surface of the skin or the surface of an internal organ exposed during surgery. The differences in the properties of emitted fluorescence may be used to distinguish between normal and pathological tissue. Tissue may be illuminated with electromagnetic energy at specific wavelengths of ultraviolet or visible light, for example. Endogenous fluorophores will absorb the energy and emit it as fluorescent light at a longer wavelength. Tissue autofluorescence may originate from aromatic amino acids such as tryptophan, tyrosine, and phenylalanine (excitation wavelengths of 200-340 nm, emission wavelengths of 360-370, 455 nm), from reduced pyridine nucleotides such as nicotinamide adenine dinucleotide (NADH, excitation wavelength of 360 nm, emission wavelength of 460 nm), from flavins and flavin nucleotides such as riboflavin and flavin mononucleotide (excitation wavelengths of 360 nm, 445-470 nm, emission wavelengths of 440 nm, 520 nm), from structural proteins such as collagen, and from lipopigments such as ceroid and lipofuscin (Chung, et al. (2005) *Current Surgery* 62:365-370; DaCosta, et al. (2005) *J. Clin. Path.* 58:766-774).

[0183] Differences in the properties of emitted autofluorescence may be used to distinguish, for example, between normal and cancerous cells and tissue in a variety of epithelial organ systems, including the cervix, colon, bladder, bronchus and oral mucosa (*Ann. Surg. Oncol.* (2003) 11:65-70; Weingandt, et al. (2002) *BJOG* 109:947-951; DaCosta, et al. (2005) *J. Clin. Path.* 58:766-775; Chiyo, et al. (2005) *Lung Cancer* 48:307-313). For example, changes in autofluorescence emission (350 to 700 nm) of premalignant or malignant lesions in the oral cavity relative to normal tissue may be detected using excitation wavelengths of 337 nm, 365 nm, and 410 nm (Gillenwater, et al. (1998) *Arch. Otolaryngol. Head Neck Surg.* 124:1251-1258). In this instance, the fluorescence intensity of normal mucosa may be greater than that of abnormal areas, while the ratio of red fluorescence (635 nm) to blue fluorescence (455-490 nm) intensities may be greater in abnormal areas. Autofluorescence may also be used to distinguish between normal and cancerous cells in non-epithelial organ systems, such as, for example, between normal white and gray matter and cancerous cells in the brain (U.S. Pat. No. 6,377,841).

[0184] Alternatively, cancerous cells may be detected using electromagnetic energy in combination with a light-activated dye. For example, Photofrin® (Axcen Pharma, Inc.) administered systemically to patients with cancer in the oral cavity, esophagus or bronchus accumulates preferentially in cancerous cells. Fluorescence of activated Photofrin® in cancer cells may be measured at 630 nm, for example, in response to excitation wavelengths of 405 nm and 506 nm 1-50 hours after administration (Braichotte, et al. (1995) *Cancer* 75:2768-2778).

[0185] As cancerous cells are identified based on differences in autofluorescence relative to normal cells using the device, the same device may be used in real time to ablate the identified cancerous cells. A cancerous cell or cells may be ablated by energy in the form of high-intensity light emitted, for example, by a laser. Lasers are commonly used to treat superficial cancers, such as basal cell skin cancer and the very early stages of some cancers, such as cervical, penile, vaginal, vulvar, and non-small cell lung cancer (National Cancer Institute (2004) *Lasers in Cancer Treatment FactSheet*). Energy emitted from a laser may also be

used to relieve certain symptoms associated with cancer, such as bleeding or obstruction. For example, a laser may be used to shrink or destroy a tumor blocking the trachea or the esophagus or to remove polyps or tumors blocking the colon or stomach.

[0186] A variety of lasers with varied excitation wavelengths and penetration potential may be used to generate electromagnetic energy sufficient to ablate a cancer cell or cells (Burr Interventional Technologies for Tissue Volume Reduction, October 2004). For example, a cancer cell or cells may be ablated using a CO₂ laser (10,600 nm, 0.1-0.2 mm penetration depth). Alternatively, cancer cells may be ablated by a Yttrium-Aluminium-Garnet (YAG) laser with Neodymium (Nd, 1064 nm or 1320 nm, 3-4 mm penetration depth), Erbium (Er, 2940 nm, with <0.1 mm penetration depth), or Holmium (Ho, 2070 nm). Alternatively, cancer cells may be ablated by diode lasers (600-1600 nm), argon laser (488 nm and 514 nm, 1-1.5 mm penetration depth), or an excimer laser (180-350 nm, cell/tissue disintegration). As such, the device may contain one or more of the lasers described herein as an optical energy source for use in exciting and/or ablating the target tissue.

[0187] Alternatively, a cancer cell or cells may be ablated by electromagnetic energy emitted from a laser in combination with a photosensitizing agent in a process termed photodynamic therapy (PDT; National Cancer Institute (2004) Lasers in Cancer Treatment FactSheet). For example, a patient may be injected with a photosensitizing agent such as, for example, Photofrin or 5-aminolevulinic acid, which after a few days concentrates in the cancerous cells. Electromagnetic energy from, for example, a laser is then used to activate the photosensitizing agent which has a subsequent toxic effect on the cancer cell or cells and results in cell death.

[0188] Alternatively, a cancer cell or cells may be ablated using x-ray energy. X-ray therapy or radiotherapy may be used to treat almost every type of solid tumor, including cancers of the brain, breast, cervix, larynx, lung, pancreas, prostate, skin, spine, stomach, uterus, or soft tissue sarcomas (National Cancer Institute (2004) Radiation Therapy for Cancer FactSheet). As such, the device may include a standard linear accelerator that emits X-ray electromagnetic energy at wavelengths sufficient for therapeutic ablation of cancerous cells. Alternatively, the device may contain a miniature X-ray emitter (see e.g. U.S. Patent Application 2004/218724 A1). Alternatively, the device may contain radioisotopes such as cobalt 60, cesium 137, or europium 152, for example, that emit strong gamma rays and may be used to ablate cancerous cells. Optionally, the device may contain other intrinsically radioactive isotope such as those that might be used for brachytherapy, including, for example, iodine 125, iodine 131, strontium 89, phosphorous, palladium, or phosphate (National Cancer Institute (2004) Radiation Therapy for Cancer FactSheet).

[0189] Alternatively, a cancer cell or cells may be ablated by using particle beam energy generated for example by a betatron, cyclotron or microtron (Podgorsak, Chapter 5). Alternatively, particle beam energy may be generated using LINAC (linear accelerator)-based external beam radiotherapy. Medical LINACs accelerate electrons to kinetic energies from 4 to 25 MeV using microwave radiofrequency waves at 10³ to 10⁴ MHz (Podgorsak, Chapter 5). A LINAC

may provide X-rays in the low megavoltage range (4 to 6 MV). Alternatively, a LINAC may provide both X-rays and electrons at various megavoltage energies, for example, two photon energies (6 and 18 MV) and several electron energies (6, 9, 12, 16, and 22 MeV; Podgorsak, Chapter 5).

[0190] Breast cancer may be detected using a device that emits electromagnetic energy at a wavelength or wavelengths sufficient to induce autofluorescence of malignant tissue. For example, an excitation-emission matrix of tissue autofluorescence generated using incremental excitation and emission wavelengths may be used to differentiate between normal and malignant breast tissue (Ann. Surg. Oncol. (2003) 11:65-70). Breast tissue may be irradiated with electromagnetic energy at excitation wavelengths of 300 to 460 nm, for example, in 10 to 20 nm increments and the resulting fluorescence emission recorded in 5 to 10 nm increments beginning with a wavelength, for example, 10 nm longer than the excitation wavelength, up to, for example, 600 nm (e.g. 360 to 600 nm for a 350 nm excitation). An excitation-emission matrix may be generated using this information and changes in peaks and valleys of fluorescence intensity may be used to distinguish between normal and malignant tissue. Optionally, a N₂ laser emitting 7 nsec pulses with a repetition rate of 10 Hz, pulse energy of 200 μJ, and filtered excitation wavelength of 337 nm may be used to distinguish between autofluorescence of normal and malignant breast tissue (Gupta, et al. (1997) Lasers Surg. Med. 21:417-422). Alternatively, cancerous breast tissue may be ablated using X-ray energy, for example, from a miniature electron beam-driven X-ray source at doses of 5 to 20 Gy (Ross, et al. (2005) Breast Cancer Res. 7:110-112). Alternatively, a breast tumor may be at least partially ablated using electron beam intra-operative radiotherapy with a radiation dose of 17 to 21 Gy (Ross, et al. (2005) Breast Cancer Res. 7:110-112).

[0191] Squamous intraepithelial lesions of the cervix may be differentiated from normal squamous tissue by autofluorescence using an electromagnetic energy emission wavelength of 460-nm (U.S. Pat. No. 5,623,932). Alternatively, cervical intraepithelial neoplasia may be differentiated from normal tissue by autofluorescence using a frequency tripled Nd:YAG laser with an excitation wavelength of 355 nm (Nordstrom, et al. (2001) Lasers Surg. Med. 29:118-127). Under these conditions, normal tissue may have an autofluorescence maxima (~460 nm) that is shifted to the left relative to neoplastic tissue (~470 nm) and is of higher intensity, allowing for differentiation between normal and abnormal tissue (Nordstrom, et al. (2001) Lasers Surg. Med. 29:118-127). Optionally, excitation wavelengths between 375 and 440 nm to induce autofluorescence may be used to distinguish between normal and precancerous lesions of the cervix (Weingandt, et al. (2002) BJOG 109:947-951). Alternatively, a fluorophore synthesized in the tissue after administration of a precursor molecule may be used in combination with electromagnetic energy to detect cancerous cells, for example, in the cervix (Andrejevic-Blant, et al. (2004) Lasers Surg. Med. 35:276-283). For example, cervical intraepithelial neoplasia may be detected by first applying 5-aminolevulinic acid topically to the cervix followed by porphyrin fluorescence spectroscopy (Keefe, et al. (2002) Lasers Surg. Med. 31:289-293). Cervical cancer may be ablated using laser conization or vaporization using, for example, a CO₂ laser focused to spot size of 0.1-0.2 mm with a continuous beam of 40-60 W and a power density of

80,000-165,000 W/cm² (Bekassy, et al. (1997) *Lasers Surg. Med.* 20:461-466) or a garnet (Nd:YAG) laser.

[0192] The early stages of melanoma may be detected using a device that emits electromagnetic energy at incremental wavelengths ranging, for example, from 400-1000 nm using, for example, an acoustic-optic tunable filter (ACTF) in combination with, for example, a white light generated with a Kr—Ar laser (Farkas, et al. (2001) *Pigment Cell Res.* 14:2-8). Spectral imaging of this sort may also be accomplished, for example, using rotating interference filters, the Fabry-Perot interferometer, liquid crystal tunable filters (LCTF), gratings or prisms, or Fourier transform spectroscopy (Chung, et al. (2005) *Current Surgery* 62:365-370). The reflected light from the potentially cancerous pigmented tissue is collected at specific wavelengths. A microprocessor may be used to generate a profile of emission intensity across the electromagnetic energy spectrum. The resulting profile may be compared with that of normal pigmented tissue to identify specific areas of dysplasia. Autofluorescence may also be used to differentiate between normal skin and non-melanoma skin lesions. For example, autofluorescence induced by an excitation wavelength of 410 nm may be used to distinguish between normal tissue, basal cell carcinoma, squamous cell carcinoma, and actinic keratosis (Panjepour, et al. (2002) *Lasers Surg. Med.* 31:367-373). Optionally, autofluorescence may be used to distinguish between sun-exposed and sun-protected areas of skin and may also indicate regions of sun damage (Davies, et al. (2001) *Applied Spectroscopy* 55:1489-1894). Once the areas of dysplasia or sun damage are identified, the device may emit in real time energy sufficient to ablate the abnormal cell or cells. For example, the lesion may be ablated using a carbon dioxide laser with a wavelength of 10,600 nm and a power output of 80 W (Gibson, et al. (2004) *Br. J. Surg.* 91:893-895).

Example 5

Detection and Ablation of Gastrointestinal Pathogens with an Untethered Ingestible Device

[0193] An untethered ingestible device may be used to detect and ablate gastrointestinal pathogens optionally in real time. The device emits electromagnetic energy at wavelengths sufficient to induce autofluorescence of pathogens within the gastrointestinal tract. Alternatively, the device emits electromagnetic energy at wavelengths sufficient to induce fluorescence of reagents added to the gastrointestinal tract to selectively detect pathogens, such as, for example, a chemical dye or an antibody or aptamer conjugated to a fluorescent tag. Pathogens may include bacteria, fungi and/or viruses. The untethered ingestible device detects the autofluorescence or reagent-induced fluorescence associated with the pathogens and in real time delivers energy sufficient to inactivate or ablate the pathogens. Optionally, the untethered ingestible device detects the autofluorescence, wirelessly transmits data to an external source, and at the discretion of the physician or other medical practitioner, a trigger mechanism, for example, is used to deliver energy sufficient to at least partially inactivate or ablate the pathogens at the coordinates associated with the autofluorescence.

[0194] Pathogens commonly associated with gastrointestinal disorders include bacteria, such as certain strains of *Escherichia coli* (e.g. *Escherichia coli* 0157:H7), various

strains of *Salmonella*, *Vibrio cholera*, *Campylobacter*, *Listeria monocytogenes*, *shigella*, and *Helicobacter pylori*, viruses such as rotavirus and Calicivirus, and parasites such as *Giardia lamblia*, *Entamoeba histolytica* and *Cryptosporidium*.

[0195] A pathogen may be detected in the gastrointestinal tract based on autofluorescence induced, for example, by electromagnetic energy. In general, pathogens such as bacteria and fungi may be detected by autofluorescence as described herein. For example, *Escherichia coli* autofluorescence may be detected using excitation wavelengths of 250-400 nm and examined at an emission wavelength of 495 nm and higher through, for example, a long pass optical filter (Glazier, et al. (1994) *J. Microbiol. Meth.* 20:23-27; Hilton, et al. (2000) *Proc. SPIE* 4087:1020-1026). Alternatively, *Escherichia coli* autofluorescence maxima of 350 nm and 485 nm may be detected following excitation at 290 nm (Cabreda, et al. (2007) *J. Fluoresc.* 17:171-180). Alternatively, *Salmonella* as well as *Escherichia coli* autofluoresce when irradiated with electromagnetic energy at a wavelength of 488 nm (Hilton (1998) *SPIE* 3491:1174-1178). The Coccidia class of bacteria, which are transmitted through a fecal-oral route via contaminated water and food and are associated with watery diarrhea, may also be detected based on autofluorescence (Bialek, et al. (2002) *Am. J. Trop. Med. Hyg.* 67:304-305). For example, *Isospora belli* and *Cyclospora* fluoresce a bluish violet color under UV excitation (365 nm) and fluoresce a bright green under violet excitation (405 nm).

[0196] A pathogen within the gastrointestinal tract may be inactivated or killed by energy emitted from an untethered ingestible device in response to detection of the pathogen by autofluorescence using the same untethered ingestible device. In general, pathogens such as bacteria and fungi may be inactivated or killed by various wavelengths of electromagnetic energy as described herein. For example, *Escherichia coli* may be partially or completely inactivated, for example, by a 60 s exposure to a UV electromagnetic energy source at wavelengths of 100-280 nm (Anderson, et al. (2000) *IEEE Transactions on Plasma Science* 28:83-88). The intestinal parasites *Cryptosporidium* and *Giardia* may also be at least partially inactivated or killed using UV irradiation from, for example, a mercury arc lamp at a fluence of 40 mJ/cm² (Li, et al. (2007) *Appl. Environ. Microbiol.* 73:2218-2223). Alternatively, *Escherichia coli* and *Salmonella enteritidis* may be inactivated using pulsed broad-spectrum electromagnetic energy with high UV content from, for example, a Xenon lamp (Anderson, et al. (2000) *IEEE Transactions on Plasma Science* 28:83-88). In this instance, targeted bacteria are subjected to 100-1000 pulses of broad-spectrum light with each pulse lasting, for example, 85 ns and having, for example, a power output of 10 MW. Alternatively, a pathogen within the gastrointestinal tract may be inactivated or killed by a particle beam, or x-ray, or gamma ray electromagnetic energy, as described herein.

[0197] *Helicobacter pylori* is a gram-negative bacterium which selectively colonizes the stomach and duodenum and is associated with chronic gastritis, gastric ulcer and increased risk for gastric adenocarcinoma. *H. pylori* may be detected in the antrum of the stomach by autofluorescence using an excitation wavelength, for example, of 405 nm (Hammer-Wilson, et al. (2007) *Scand. J. Gastroenterol.*

42:941-950). *H. pylori* naturally accumulates coproporphyrin and protoporphyrin which sensitize the bacteria to inactivation by visible light at wavelengths ranging from 375 to 425 nm (Hamblin, et al. (2005) *Antimicrob. Agents Chemother.* 49:2822-2827; U.S. Patent Application 2004/0039232 A1). As such, an untethered ingestible device emitting electromagnetic energy as described herein may be used to detect and at least partially inactivate or kill *H. pylori* in the gastrointestinal tract.

[0198] The untethered ingestible device may transit through the gastrointestinal tract by natural peristalsis after ingestion. Transit times may vary depending, for example, on the time required for gastric emptying and for transit through the small bowel. For example, transit time of an untethered ingestible device out of the stomach may range from 20-160 minutes depending upon, for example, the age of the patient and whether polyethylene glycol (PEG 400) or erythromycin are administered prior to and following ingestion of the device (Fireman, et al. (2005) *World J. Gastroenterol* 11:5863-5866). Similarly, transit time through the small bowel may range from 220-320 minutes depending, for example, upon the age of the patient and co-administered agents (Fireman, et al. (2005) *World J. Gastroenterol* 11:5863-5866).

[0199] The untethered ingestible device may be affixed to a specific site within the gastrointestinal tract, for example, by expanding to fill the lumen of the tract (U.S. Patent Application 2007/015621 A1). As such, the untethered ingestible device may be cylindrical in shape with a central core enabling free flow of fluids within the digestive tract.

[0200] Optionally, the untethered ingestible device may contain a means of locomotion with internal or external control that allows an operator to control movement of the device within the gastrointestinal tract. The device may use a locomotion system based on "inch-worm" motion using, for example, grippers and extensors, rolling tracks, or rolling stents (Rentschler, et al. (2006) SAGES Meeting; Rentschler, et al. (2007) *Surg. Endosc.* on-line ahead of publication). Alternatively, the device may use a helical wheel configuration on its surface with, for example, two independent motors that control the wheels, providing forward, backward, and turning capacity (see, e.g., Rentschler, et al. (2006) SAGES Meeting; Rentschler, et al. (2007) *Surg. Endosc.* on-line ahead of publication; U.S. Patent Application 2006/119304 A1). Alternatively, the device may use a locomotion system based on wheels or expanding and contracting components (see, e.g., U.S. Patent Application 2006/119304 A1).

Example 6

Detection and Ablation of Pathological Gastrointestinal Tissue with an Untethered Ingestible Device

[0201] An untethered ingestible device may be used to detect and ablate pathological gastrointestinal tissue in real time. The device emits electromagnetic energy at wavelengths sufficient to induce autofluorescence of pathological tissue within the gastrointestinal tract. Alternatively, the device emits electromagnetic energy at wavelengths sufficient to cause fluorescence of reagents added to the gastrointestinal tract to selectively detect pathological tissue,

such as, for example, a chemical dye or an antibody or aptamer conjugated to a fluorescent tag. Pathological tissue may include, for example, cancer or lesions associated with Crohns disease. The untethered ingestible device detects the autofluorescence or reagent-induced fluorescence associated with the pathological tissue and in real time delivers energy sufficient to at least partially ablate the pathological tissue. Optionally, the untethered ingestible device detects the autofluorescence, wirelessly transmits data to an external source, and at the discretion of the physician or other medical practitioner, a trigger mechanism, for example, is used to deliver energy sufficient to at least partially ablate the pathological tissue at coordinates associated with the autofluorescence.

[0202] For example, changes in autofluorescence emission (350 to 700 nm) of premalignant or malignant lesions in the oral cavity relative to normal tissue may be detected using excitation wavelengths of 330, nm, 337 nm, 365 nm, and 410 nm (Gillenwater, et al. (1998) *Arch. Otolaryngol. Head Neck Surg.* 124:1251-1258; Tsai, et al. (2003) *Lasers Surg. Med.* 33:40-47). In this instance, the fluorescence intensity of normal mucosa may be greater than that of abnormal areas, while the ratio of red fluorescence (635 nm) to blue fluorescence (455-490 nm) intensities may be greater in abnormal areas. Alternatively, autofluorescence induced by excitation wavelengths of 365, 385, 405, 420, 435, and 450 nm may be combined with diffuse reflectance spectroscopy to detect pre-malignant and malignant lesions in the oral mucosa (de Veld, et al. (2005) *Lasers Surg. Med.* 36:356-364). Based on the relative autofluorescence, the cancerous cells may be identified and irradiated with electromagnetic energy sufficient to ablate the cell or cells, as described herein.

[0203] Autofluorescence may be used to distinguish between normal and neoplastic tissue in patients with Barrett's esophagus (Borovika, et al. (2006) *Endoscopy* 38:867-872; Pfefer, et al. (2003) *Lasers Surg. Med.* 32:10-16) For example, fluorescence spectra excited at 337 nm and 400 nm may be used to distinguish between normal and neoplastic tissue (Pfefer, et al. (2003) *Lasers Surg. Med.* 32:10-16). Alternatively, fluorescence maxima may be compared at various emission wavelengths, for example, 444, 469, 481, 486, 545, 609, and 636 nm following excitation at 337 nm and 400 nm. Autofluorescence may be observed with a long-pass filter with a cut-off wavelength >470 nm to optimize fluorescence detection and minimize excitation light (Borovika, et al. (2006) *Endoscopy* 38:867-872). Alternatively, adenocarcinoma in patients with Barrett's esophagus may be detected using electromagnetic energy in combination with an agent that concentrates in cancerous cells and that fluoresces upon laser excitation, such as, for example, Photofrin® (von Holstein, et al. (1999) *Gut* 39:711-716).

[0204] Autofluorescence may be used to distinguish between normal, hyperplastic and adenomatous colonic mucosa (DaCosta, et al. (2005) *J. Clin. Path.* 58:766-774; Eker, et al. (1999) *Gut* 44:511-518). Irradiation of colon mucosa with ultraviolet light or blue light with a wavelength of 488 nm, for example, induces emission of green and red regions of autofluorescence. In normal tissue, collagen and elastin emit weak green fluorescence. In hyperplastic tissue or polyps, increased collagen produces intense green fluorescence. Dysplastic or malignant lesions may have

enhanced red fluorescence compared with either normal or hyperplastic polyps (DaCosta, et al. (2005) J. Clin. Path. 58:766-774).

[0205] An untethered ingestible device emitting electromagnetic energy at a wavelength or wavelengths sufficient to induce autofluorescence such as ultraviolet or blue light, for example, is used to irradiate the colon. Fluorescence emission is detected at wavelengths of 505-550 nm and >585 nm, for example, to detect the green and red autofluorescence, respectively. Alternatively, shifts in the autofluorescence emission maxima following excitation at 337 nm may be used to distinguish normal from adenomatous tissue (Eker, et al. (1999) Gut 44:511-518).

[0206] Optionally, electromagnetic energy may be combined with 5-aminolevulinic acid (ALA) to differentiate between normal colon tissue and adenomatous polyps (Eker, et al. (1999) Gut 44:511-518). For example, ALA at a dose of 5 mg/kg body weight may be administered orally to patients 2 to 3 hours prior to investigation followed by irradiation of the colon tissue with excitation wavelengths of 337 nm, 405 nm, and 436 nm. Normal versus abnormal tissue may be distinguished based on relative shifts in the emission maxima (Eker, et al. (1999) Gut 44:511-518).

[0207] Based on the relative autofluorescence, the cancerous cells are identified and may be irradiated with energy sufficient to ablate the cell or cells, as described herein. For example, colorectal adenomas may be ablated using an Nd:YAG (1064 nm) with maximal power output of 100 W (Norberto, et al. (2005) Surg. Endosc. 19:1045-1048). Alternatively, X-ray energy administered at a total dose of 20 Gy may be used to treat colon cancer (Kosmider, et al. (2007) World J. Gastroenterol. 13:3788-3805).

[0208] Autofluorescence imaging may be used to detect the severity of ulcerative colitis (Fujiya, et al. (2007) Dig. Endoscopy 19 (Suppl. 1):S145-S149). For example, differences in inflammatory state may be distinguished by autofluorescence, with severely inflamed mucosa associated with purple autofluorescence, atrophic regenerative mucosa associated with faint purple autofluorescence with green spots, and normal mucosa associated with green autofluorescence.

Example 7

Detection and Ablation of Pathogens in a Lumen with an Untethered Device

[0209] An untethered device may be used to detect and ablate pathogens within a lumen in real time. The device emits electromagnetic energy at wavelengths sufficient to induce autofluorescence of pathogens within the lumen. Alternatively, the device emits electromagnetic energy at wavelengths sufficient to cause fluorescence of reagents added to the lumen to selectively detect pathogens, such as, for example, a chemical dye or an antibody or aptamer conjugated to a fluorescent tag. Pathogens may include bacteria, fungi and/or viruses. A lumen may include that associated with blood vessels, the urogenital tract, and the respiratory tract, for example. The untethered luminal device detects the autofluorescence or reagent-induced fluorescence associated with the pathogens and in real time delivers energy sufficient to inactivate or ablate the pathogens. Optionally, the untethered luminal device detects the autofluorescence, wirelessly transmits data to an external source,

and at the discretion of the physician or other medical practitioner, a trigger mechanism, for example, is used to deliver energy sufficient to at least partially ablate the pathogen at coordinates associated with the autofluorescence.

[0210] An untethered device in the lumen of a blood vessel may be used to detect and ablate pathogens associated with blood infections or septicemia. Gram-negative enteric bacilli, *Staphylococcus aureus*, and *Streptococcus pneumoniae* are the most common pathogens in the United States associated with micronemia and sepsis. As such, electromagnetic energy emitted from a luminal device may be used to detect autofluorescence associated, for example, with blood borne bacteria as described herein. The pathogens are subsequently ablated using, for example, UV electromagnetic energy as described herein.

[0211] An untethered device in the lumen of a blood vessel may be used to detect and ablate parasites in the blood stream. For example, autofluorescence associated with the food vacuole of the malaria parasite *Plasmodium* spp. may be used to detect infected erythrocytes with in the blood stream (Wissing, et al. (2002) J. Biol. Chem. 277:37747-37755). As such, an untethered luminal device may induce autofluorescence of parasites at a wavelength, for example, of 488 nm (Wissing, et al. (2002) J. Biol. Chem. 277:37747-37755). Alternatively, erythrocytes infected with *Plasmodium* spp. may be detected by pre-staining the cells with acridine orange, which when excited at 490 nm emits green light at 530 nm (Wissing, et al. (2002) J. Biol. Chem. 277:37747-37755). Other nucleic-acid binding dyes may be used for this purpose including Hoechst 33258, thiazole orange, hydroethidine, and YOYO-1 (Li, et al. (2007) Cytometry 71A:297-307). As such, the dyes bind to parasite DNA in the infected erythrocytes which are otherwise free of DNA. Erythrocytes autofluoresce upon excitation at a wavelength of 545 nm with an emission wavelength of 610 nm associated with the heme porphyrin (Liu, et al. (2002) J. Cereb. Blood Flow Metab. 22:1222-1230). As such, the untethered luminal device may optionally first identify an erythrocyte based on autofluorescence at one wavelength, followed by detection of a parasite within the erythrocyte based on autofluorescence or dye induced fluorescence at a second wavelength. The untethered luminal device may detect fluorescence associated with infected erythrocytes and in real time emit energy at wavelengths sufficient to at least partially ablate the infected cells.

[0212] An untethered luminal device may be used to detect and ablate pathogens associated with urinary tract infections (UTI), for example, in the lumen of the bladder. For example, *Escherichia coli* uropathogenic strains are the most common cause of urinary tract infections (Finer, et al. (2004) Lancet Infect. Dis. 4:631-635). *Escherichia coli* may be detected in the bladder, for example, using electromagnetic energy to induce autofluorescence as described herein. An untethered luminal device may be inserted into the bladder via a catheter. Once inserted, the untethered luminal device may scan the internal surface of the bladder with electromagnetic energy sufficient to induce autofluorescence of pathogens. In response to autofluorescence, the untethered luminal device may emit energy sufficient to at least partially inactivate pathogens, as described herein.

[0213] Optionally, the untethered luminal device may be affixed to a specific site within a lumen, for example, by

expanding to fill the lumen (see, e.g., U.S. Patent Application 2007/015621 A1). As such, the untethered luminal device may be cylindrical in shape with a central core enabling free flow of fluids within the lumen. Alternatively, the untethered luminal device may be affixed to a specific site within a lumen using, for example, a hook or claw-like structure, an adhesive or glue-like material, or suction (see, e.g., U.S. Patent Application 2007/015621 A1).

[0214] Optionally, the untethered luminal device may contain a means of locomotion with internal or external control that allows an operator to control movement of the device within the lumen by means described herein. Alternatively, the untethered luminal device may be controlled by external magnetic energy. For example, an untethered luminal device in an artery, for example, may be manipulated using a clinical magnetic resonance imaging system (see, e.g., Mathieu, et al. Proceedings of the 2005 IEEE, Engineering in Medicine and Biology 27th Annual Conference, Shanghai, China, Sep. 1-4, 2005, 4850-4853; Martel, et al. (2007) Applied Physics Letters 90:114105-1-3). As such, the untethered luminal device may be constructed, at least in part, with ferromagnetic material.

Example 9

Detection and Ablation of Pathological Tissue in a Lumen with an Untethered Device

[0215] An untethered device may be used to detect and ablate pathological tissue or cells within a lumen in real time. The device emits electromagnetic energy at wavelengths sufficient to induce autofluorescence of pathological tissue within the lumen. Alternatively, the device emits electromagnetic energy at wavelengths sufficient to cause fluorescence of reagents added to the lumen to selectively detect pathological tissue, such as, for example, a chemical dye or an antibody or aptamer conjugated to a fluorescent tag. Pathological tissue may include cancer, atherosclerosis, and inflammation, for example. A lumen may include that associated with blood vessels, the urogenital tract, and the respiratory tract, for example. The untethered luminal device detects the autofluorescence or reagent-induced fluorescence associated with the pathogens and in real time delivers energy sufficient to inactivate or ablate the pathological tissue. Optionally, the untethered luminal device detects the autofluorescence, wirelessly transmits data to an external source, and at the discretion of the physician or other medical practitioner, a trigger mechanism, for example, is used to deliver energy sufficient to at least partially ablate the pathological tissue at coordinates associated with the autofluorescence.

[0216] An untethered device in the lumen of a blood vessel, for example, may be used to detect and ablate tissue and cells associated with, for example, an atherosclerotic plaque. For example, autofluorescence associated with macrophages in a plaque may be used to characterize an atherosclerotic lesion (Marcu, et al. (2005) Atherosclerosis 181:295-303). The accumulation of macrophages in the fibrous cap of an atherosclerotic plaque are indicative of inflammation as well as instability of the plaque. The lumen of a blood vessel may be irradiated, for example, with 1 ns pulses of electromagnetic energy at a wavelength of 337 nm. The resulting autofluorescence may be detected at specific maxima wavelengths, for example, 395 nm and 450 nm, or

over a range of wavelengths, for example, from 300-600 nm (Marcu, et al. (2005) Atherosclerosis 181:295-303). Differences in the autofluorescence spectra may be used to differentiate between normal, collagen thick and macrophage thick plaques (Marcu, et al. (2005) Atherosclerosis 181:295-303). Alternatively, the lumen of a blood vessel may be irradiated with electromagnetic energy ranging in wavelength from 350 to 390 nm and the resulting autofluorescence detected at critical wavelengths, for example, of 570, 600, 480, or 500 nm may be sufficient to differentiate between structurally viable tissue and an atherosclerotic plaque (U.S. Pat. No. 5,046,501).

[0217] The untethered device may subsequently in real time emit energy sufficient to at least partially ablate the atherosclerotic plaque based on the differential autofluorescence. An excimer laser operating in the ultraviolet range may be used to ablate an atherosclerotic plaque (Morguet, et al. (1994) Lasers Surg. Med. 14:238-248). Alternatively, other laser systems may be used to ablate an atherosclerotic plaque, including, for example, a CO₂ laser, Nd:YAG laser or an argon laser (Morguet, et al. (1994) Lasers Surg. Med. 14:238-248).

[0218] An untethered device in the lumen of a blood vessel, for example, may be used to detect and ablate cells associated with, for example, a hematological form of cancer. For example, leukemia is characterized by an increase in immature lymphoblasts in circulation. These cells may have a distinct autofluorescence relative to normal lymphocytes. As such, fluorescence associated with the lymphoblasts may be detected and the cells subsequently ablated using the methods described herein.

[0219] An untethered device in the lumen of a blood vessel may be used to detect and ablate cells that have migrated from a solid tumor and are on route to metastasis elsewhere in the body. These cells may be identified using the untethered device to generate and detect autofluorescence. Alternatively, these cells may be identified using the untethered device to induce and detect fluorescence associated with a reagent that specifically binds to a cancer cell, such as a fluorescent antibody or aptamer. For example, circulating tumor cells associated with breast cancer may be detected using a fluorescently tagged antibody or aptamer to a tumor specific cell-surface antigen such as, for example, the Her2/Neu epidermal growth factor receptor (Gilbey, et al. (2004) J. Clin. Pathol. 57:903-911). Patients with increased breast epithelial cells in circulation have a higher rate of metastasis and poorer outcome. As such, fluorescence associated with the breast cancer cell may be detected and the cell subsequently ablated by the untethered luminal device using the methods described herein.

Example 10

Detection and Ablation of Pathogens in a Lumen with a Tethered Device

[0220] A tethered device may be used to detect and ablate pathogens within a lumen in real time. The device emits electromagnetic energy at wavelengths sufficient to induce autofluorescence of pathogens within the lumen. Alternatively, the device emits electromagnetic energy at wavelengths sufficient to cause fluorescence of reagents added to the lumen to selectively detect pathogens, such as, for

example, a chemical dye or an antibody or aptamer conjugated to a fluorescent tag. Pathogens may include bacteria, fungi and/or viruses. A lumen may include that associated with blood vessels, gastrointestinal tract, the urogenital tract, or the respiratory tract, for example. The tethered luminal device detects the autofluorescence or reagent-induced fluorescence associated with the pathogens and in real time delivers energy sufficient to inactivate or ablate the pathogens.

[0221] A tethered device in the lumen of a blood vessel, for example, may be used to detect and ablate pathogens in the blood such as those associated with septicemia and malaria using electromagnetic energy, as described herein.

[0222] A tethered device in the lumen of the lung, for example, may be used to detect and ablate pathogens associated with bronchial infections, such as bronchitis, pneumonia, and tuberculosis. *Streptococcus pneumoniae* is the most common cause of community-acquired pneumonias whereas *Pseudomonas aeruginosa*, *Escherichia coli*, *Enterobacter*, *Proteus*, and *Klebsiella* are commonly associated with nosocomial-acquired pneumonia. Although the incidence of tuberculosis is low in industrialized countries, *M tuberculosis* infections still continue to be a significant public health problem in the United States, particularly among immigrants from developing countries, intravenous drug abusers, patients infected with human immunodeficiency virus (HIV), and the institutionalized elderly. Autofluorescence induced by electromagnetic energy may be used to detect various bacterial pathogens, as described herein. A tethered device may be inserted into the lung comparable, for example, to a bronchoscope, and used to detect pathogens. In response to autofluorescence, the same tethered device may emit in real time energy sufficient to at least partially inactivate pathogens, as described herein.

Example 11

Detection and Ablation of Pathological Tissue in a Lumen with Tethered Device

[0223] A tethered device may be used to detect and ablate pathological tissue or cells within a lumen in real time. The device emits electromagnetic energy at wavelengths sufficient to induce autofluorescence of pathological tissue within the lumen. Alternatively, the device emits electromagnetic energy at wavelengths sufficient to cause fluorescence of reagents added to the lumen to selectively detect pathological tissue, such as, for example, a chemical dye or an antibody or aptamer conjugated to a fluorescent tag. Pathological tissue may include cancer, atherosclerosis, and inflammation, for example. A lumen may include those associated with blood vessels, the urogenital tract, the gastrointestinal tract, or the respiratory tract, for example. The tethered luminal device detects the autofluorescence or reagent-induced fluorescence associated with the pathological tissue and in real time automatically delivers energy sufficient to at least partially ablate the pathological tissue.

[0224] Autofluorescence induced by an optical energy source may be used to detect pathological tissue as described herein. Alternatively, fluorescence associated with a selective marker may be induced by an optical energy source to detect pathological tissue as described herein. A tethered device that emits optical energy to induce autofluorescence

of pathological tissue may be configured, for example, like an endoscope (see, e.g., U.S. Patents U.S. Pat. No. 5,507,287; U.S. Pat. No. 5,590,660; U.S. Pat. No. 5,647,368; U.S. Pat. No. 5,769,792; U.S. Pat. No. 6,061,591; U.S. Pat. No. 6,123,719; U.S. Pat. No. 6,462,770B1). As such, a flexible optical tube sufficiently small enough to be inserted into a lumen may be attached to an optical energy source that emits wavelengths sufficient to induce autofluorescence such as for example, a nitrogen laser. The same flexible tube may transmit the emitted autofluorescence back to a CCD camera and control circuitry. Immediately upon receiving the emitted autofluorescence indicative of pathological tissue, a second emission of energy, from for example an Nd:YAG laser, is released to at least partially ablate the pathological tissue. Alternatively, the head of the flexible tube may contain a photodiode array sensor that directly detects the autofluorescence and triggers a second emission of energy sufficient to at least partially ablate the pathological tissue. Alternatively, the head of the flexible tube may contain shielded gamma emitting isotopes that exposure the tissue to radiation in real time in response to the detected autofluorescence.

[0225] A tethered device in the lumen of a blood vessel, for example, may be used to detect and ablate pathological tissue, for example, atherosclerotic plaques or circulating cancer cells as described herein.

[0226] Autofluorescence in combination with reflected light may be used to differentiate between normal, inflamed and pre-invasive lesions in the lung (Chiyo, et al. (2005) Lung Cancer 48:307-313; Gabrecht, et al. (2007) SPIE-OSA Vol. 6628, 66208C-1-8; US U.S. Pat. No. 5,507,287). For example, bronchial tissue may be irradiated with excitation wavelengths of 395-445 nm and autofluorescence detected at wavelengths of 490-690 nm. Simultaneously or subsequently, reflected light at 550 nm (green) and at 610 nm (red) may be collected and combined with the autofluorescence data to form a composite image. As such, the ratios of green/red and green/autofluorescence may be greater in squamous dysplasia relative to inflamed lung tissue associated with bronchitis, allowing for differentiation between these two disease states (Chiyo, et al. (2005) Lung Cancer 48:307-313). Based on the relative autofluorescence detected, the tethered device emits energy sufficient to at least partially ablate the cancerous tissue. For example, electromagnetic energy sufficient to ablate cancerous cells in the lung may be generated by a Neodymium YAG laser (1064 nm) with power output up to 100 W and tissue penetration of 1-5 mm (Hansen, et al. (2006) Minim. Invasive Ther. Allied Technol. 15:4-8).

Example 12

An Apparatus for Detection and Ablation of Pathogens and Pathological Tissue

[0227] FIG. 26, FIG. 27, and FIG. 28 show illustrative configurations of handheld versions of an apparatus 100 of FIG. 1. for the detection and ablation of pathogens and pathological tissue.

[0228] FIG. 26 shows an illustrative configuration of a handheld device 2000 which is completely self-contained and easily held in the hand of the user 2001. The user 2001 may be, for example, a surgeon or other medical practitioner

and/or a veterinarian, using the handheld device **2000**, for example, in a surgical theater, a hospital emergency room, a doctor, dentist, veterinary, or nurse practitioner's office. Alternatively, the user **2001** may be an emergency responder, using the hand held device **2000**, for example, out in the field at the site of an accident or on the battlefield. The user **2001** may hold the handheld device **2000** in proximity to a lesion or lesions **2002** on a patient **2003**. The lesion **2002** may be a surgical incision or a wound. A wound, for example, may be an abrasion, a burn, a puncture, or a deep gouge. Alternatively, the lesion **2002** may be on the surface of the skin or the surface of the oral cavity. The user **2001** turns on the handheld device **2000** using an on/off switch **2004**. Optionally, the user **2001** may use a button **2005** on the handheld device **2000** to activate or enable a beam of energy **2006** (optionally the same as **110**). The user **2001** activates a beam of energy **2006** in proximity to the lesion **2002** to detect and ablate pathogens and pathological tissue.

[0229] FIG. 27 shows an illustrative configuration of a handheld device **2007** which is held in the hand of the user **2001** and is optionally wirelessly connected to optional external control circuitry **2008**. Optionally, the handheld device **2007** is connected via a wire **2009** to external control circuitry **2008** or an external power source **2010**, or both. The user **2001** activates a beam of energy **2006** in proximity to the lesion **2002** to detect and ablate pathogens and pathological tissue.

[0230] FIG. 28 shows an illustrative configuration of a handheld device **2011** which is held in the hand of the user **2001**, and is used in conjunction with targeting aids **2014** surrounding the lesion **2002** on the surface of the patient **2003**. The targeting aids **2014** are used, for example, to register the position of autofluorescence associated with pathogens or pathological tissue within the lesion **2002** with respect to the surface of the patient **2003**. As such, the user **2001** may screen the entire lesion **2002**, noting the position of possible pathogens or pathological tissue. The user **2001** may subsequently return to specific regions of concern and at the discretion of the user **2001**, manually initiate ablation using, for example, a trigger **2012**. The handheld device **2011** may include a monitor **2013** that allows the user **2001** to observe the autofluorescence emitted from the lesion **2002** in real time and/or to observe a targeting beam of optionally visual light indicating the location of emitted energy for excitation and/or ablation.

[0231] Alternatively, the handheld device may be connected to an external display device and control circuitry **2008** as described in FIG. 27. The user **2001** places at least three targeting aids around the lesion **2002** on the patient **2003**. The user **2001** scans the surface of the lesion **2002** with the handheld device **2011** and data is collected regarding the position of autofluorescence associated with a pathogen or pathological tissue. The user **2001** may analyze the accumulated data and at the discretion of the user **2001**, return to specific regions of the lesion **2002** and use the trigger **2012** to initiate or enable irradiation with a beam of energy **2006** to ablate pathogens or pathological tissue. Alternatively, the targeting aids **2014** may be placed on fixed surfaces, for example, of the examination room. As such, the extremity with the lesion **2002** is immobilized to an examining surface, for example, to aide in location registration.

[0232] FIG. 29 shows an illustrative configuration of a stationary version of the apparatus **100** for the real time

detection and ablation of pathogens and pathological tissue. The stationary device **2015** may be a component of a room **2016** that is, for example, part of a surgical theater, an imaging and treatment facility, or a doctor's or dentist's or veterinarian's office. The stationary device **2015** may be used in conjunction with targeting aids **2014** placed at various locations around the room **2016**. In the example shown in FIG. 29, the targeting aids **2014** are affixed to the walls **2017** of the room **2016**. Alternatively, the targeting aids **2014** may be affixed to the ceiling, to the floor or to objects within the room, or a combination thereof.

[0233] The user **2001** may control the stationary device **2015** using control circuitry **2008** optionally in an auxiliary room **2018** optionally visually connected to the main room **2016** by a window or other viewing means, for example. The room **2016** may also contain a table **2019** upon which there is optionally a sliding platform **2020** for moving the patient **2003** into position relative to the stationary device **2015**. The sliding platform **2020** may also have strategically placed targeting aids **2014**. Alternatively, targeting aids **2014** may be placed on the patient **2003** in proximity to the lesion **2002** as described herein. In an alternative configuration, the patient **2003** may remain stationary on a table **2019** while some component of the stationary device **2015** is moved into the appropriate position relative to the lesion **2002**.

[0234] The user **2001** may scan a lesion **2002** with the stationary device **2015** using a beam of energy **2006** to detect autofluorescence associated with pathogens or pathological tissue. The beam of energy **2006** exciting the autofluorescence associated with the pathogen or pathological tissue may be emitted, for example, from a mercury arc lamp, a Xenon lamp, a UV eximer, a halogen lamp, a laser or light emitting diode at wavelengths ranging, for example, from 200 nm to 1000 nm. The stationary device **2015** may automatically ablate the pathogen or pathological tissue based on the emitted autofluorescence. Alternatively, data may be collected regarding the position of autofluorescence associated with a pathogen or pathological tissue. The user **2001** may analyze the accumulated data and at the discretion of the user **2001**, return to a specific region of the lesion **2002** based on orientation from the targeting aids **2014** and instruct the stationary device **2015** to emit a second beam of energy **2006** to ablate pathogens or pathological tissue. The second beam of energy **2006** may or may not be of the same wavelength and intensity as the first beam of energy **2006** used to excite fluorescence. The beam of energy **2006** inducing ablation of pathogens or pathological tissue may be an optical energy source, such as those described above, an X-ray energy source, a particle beam energy source, or a combination thereof.

[0235] FIG. 30, FIG. 31, and FIG. 32 show schematic representations of illustrative configurations of handheld versions of an apparatus **100** for the detection and ablation of pathogens and pathological tissue.

[0236] FIG. 30 shows a schematic representation of an illustrative configuration of a completely self-contained handheld device **2021** for the detection and ablation of pathogens and pathological tissue. The handheld device **2021** contains a power source **2022** which powers the control circuitry **2023**, the optical energy source **2024**, and other components of the device **2021**. The optical energy source **2024** may be, for example, a mercury arc lamp, a

Xenon lamp, a UV eximer, a halogen lamp, a nitrogen laser or a laser diode. The electromagnetic energy 2029 emitted from the optical energy source 2024 may pass through a filter 2025 that allows for emission of specific wavelengths appropriate for inducing autofluorescence of pathogens or pathological tissue as described herein. The electromagnetic energy 2029 may pass through a lens 2026 to focus the energy and optionally through a chromatic beam splitter 2027. The electromagnetic energy 2029 hits the lesion 2002 resulting in emission of autofluorescence 2030. The autofluorescence 2030 is detected by a sensor 2028 and as a result a second wave of electromagnetic energy 2029 is emitted in real time from the optical energy source 2024 at a wavelength and intensity sufficient to ablate the detected pathogen or pathological tissue as described herein.

[0237] FIG. 31 shows a schematic representation of an illustrative configuration of a handheld device 2031 in which separate energy sources are optionally used for detection and ablation of pathogens or pathological tissue. The handheld device 2031 may be powered by an internal power supply 2022. Optionally, the handheld device may be connected to an external power supply. The handheld device 2031 may be controlled by internal control circuitry 2023. Optionally, the handheld device 2031 may be connected either with or without wires to external control circuitry. The handheld device 2031 contains at least one optical energy source 2032. The handheld device 2031 may also contain a least one additional energy source 2033 for the ablation of pathogens or pathological tissue. The energy source 2033 may be an optical energy source, an X-ray source, or a particle beam source, or a combination thereof.

[0238] Electromagnetic energy 2029 emitted from the optical energy source 2032 may pass through a filter 2025 that allows for emission of specific wavelengths appropriate for inducing autofluorescence of pathogens or pathological tissue as described herein. The electromagnetic energy 2029 may pass through a lens 2026, a series of beam splitters 2027, and through a final lens 2026 prior to hitting the lesion 2002. The autofluorescence 2030 emitted by pathogens or pathological tissue in the lesion 2002 is detected by the sensor 2028. As a result, a second beam of electromagnetic energy 2029 may be emitted from the first optical energy source 2032. Alternatively, a second beam of energy 2034 may be emitted from the second energy source 2033 which is a level of energy sufficient to ablate a pathogen or pathological tissue as described herein. The ablation energy may pass through portions of the same beam path, or may use a fully or partially dedicated beam path.

[0239] FIG. 32 shows a schematic representation of an illustrative configuration of a handheld device 2035 in which multiple energy sources are optionally used for position, detection and ablation of pathogens or pathological tissue. As shown in FIG. 32A, the handheld device 2035 may include a monitor 2036 for observing the autofluorescence associated with a pathogen or a pathological tissue. Optionally, the handheld device 2035 may be connected with or without wires to an external display device. The handheld device 2035 may include a control panel 2037 allowing for entry of commands by the user. Optionally, the handheld device 2035 may be connected with or without wires to an external control panel associated, for example, with a computer. The handheld device may be turned on and off via a switch 2004.

[0240] As shown in FIG. 32B, the handheld device 2035 may be powered by an internal power supply 2022. Optionally, the handheld device may be connected to an external power supply. The handheld device 2035 may be controlled by internal control circuitry 2023. Optionally, the handheld device 2035 may be connected either with or without wires to external control circuitry. The handheld device 2035 contains at least one optical energy source 2032. The handheld device 2035 may also contain at least two additional energy sources 2033 for the ablation of pathogens or pathological tissue. The energy source 2033 may be an optical energy source, an X-ray source, or a particle beam source, or a combination thereof. The handheld device 2035 may also contain at least one targeting energy source 2038 for positioning the autofluorescence associated with a pathogen or pathological tissue relative to one or more targeting sensors, as described herein.

[0241] Energy emitted from the optical energy source 2032 may pass through a filter/focus unit 2039 that allows for emission of specific wavelengths appropriate for inducing autofluorescence of pathogens or pathological tissue as described herein. The autofluorescence emitted by pathogens or pathological tissue in a lesion is detected by the sensor 2028. The position of the autofluorescence in the lesion may be determined with the aide of the targeting energy source 2038 and targeting sensors positioned, for example, on the surface of the patient in proximity to the lesion or on various surfaces in a room or a combination thereof as described herein. After the autofluorescence is detected, a second beam of electromagnetic energy may be emitted from the first optical energy source 2032. Alternatively, a second beam of energy may be emitted from the second or third energy source 2033 at a level of energy sufficient to ablate a pathogen or pathological tissue as described herein.

[0242] As shown in FIG. 32C, energy emitted from or detected by the device 2035 passes through one or more openings 2040 at the bottom of the device 2035.

[0243] FIG. 33 and FIG. 34 show illustrative configurations of untethered versions of a device 200, 300 and/or 400 for the detection and ablation of pathogens and pathological tissue in the lumen, for example, of a blood vessel.

[0244] FIG. 33 shows an illustrative configuration of an untethered device 2041 for the detection and ablation of pathogens and pathological tissue in the lumen 2042 of a blood vessel, for example. Alternatively, the untethered device 2041 may be used in other lumens including those associated with the gastrointestinal tract, the respiratory tract, and the urogenital tract, for example. In this configuration, the untethered device 2041 may be a hollow cylinder that when placed in a lumen 2042 allows for the flow of fluid and cells 2043 through the central core 2045 of the cylinder. The hollow cylinder contains a detection and ablation unit 2047, which optionally contains a power source, control circuitry, one or more energy sources, and a sensor. Control of the device may be completely self-contained or controlled wirelessly by an external user.

[0245] As normal cells 2043 and abnormal cells 2044 pass through the central core 2045 of the untethered device 2041, the detection and ablation unit 2047 detects autofluorescence associated with the abnormal cells 2044 and in real time ablates the abnormal cells 2044. Abnormal cells 2044 may

be, for example, pathogens, pathological cells or cancerous cells as described herein. The untethered device **2041** may be reversibly fixed in a specific region of the lumen by virtue of inflatable pouches **2046** or other means.

[**0246**] FIG. **34** shows an illustrative configuration of an untethered device **2048** for the detection and ablation of pathogens and pathological tissue in the lumen **2042**, for example, of a blood vessel. Alternatively, the untethered device **2048** may be used in other lumens including those associated with the gastrointestinal tract, the respiratory tract, and the urogenital tract, for example. In this configuration, the untethered device **2048** may be fixed to the surface of a lumen by virtue of a hook **2049** which at the appropriate time and location latches on to the surface of the lumen. Control of the untethered device **2048** may be completely self-contained or controlled wirelessly by an external user. The untethered device **2048** may sit on the surface of a lumen and monitor the flow of fluid and normal cells **2043** and abnormal cells **2044**. The untethered device **2048** emits a beam of energy **2006** which detects abnormal cells **2044** based on autofluorescence and in real time ablates the abnormal cells.

[**0247**] FIG. **35**, FIG. **36**, and FIG. **37** show illustrative configurations of untethered versions of an apparatus **100** with controlled locomotion for the detection and ablation of pathogens and pathological tissue in a lumen associated with, for example, the circulatory system, the gastrointestinal tract, the respiratory tract, or the urogenital tract.

[**0248**] FIG. **35** shows an illustrative configuration of an untethered device **2050** with controlled locomotion for the detection and ablation of pathogens and pathological tissue in a lumen **2042**. In this configuration, the untethered device **2050** is a hollow cylinder and has two or more controllable wheels **2051** that allow the device to move along the surface of a lumen. Control of the movement of the untethered device **2050** may be completely self-contained or controlled wirelessly by an external user. The hollow cylinder contains a detection and ablation unit **2047**, which optionally contains a power source, control circuitry, one or more energy sources, and a sensor. As the untethered device moves along the surface of a lumen, a beam of energy **2006** is emitted towards the surface, for example, scanning for autofluorescence associated with a pathogen or pathological tissue. Once autofluorescence is detected, the untethered device **2050** emits a beam of energy **2006** from the detection and ablation unit **2047** sufficient to ablate the pathogen or pathological tissue.

[**0249**] FIG. **36** shows an illustrative configuration of an untethered device **2052** with controlled locomotion for the detection and ablation of pathogens and pathological tissue in a lumen **2042**. In the configuration shown, the untethered device **2052** is a sphere. Optionally, the untethered device **2052** may be any configuration that is compatible with housing the components necessary for detection and ablation of pathogens or pathological tissue in a lumen **2042**. The untethered device **2052** has two propellers **2053** mounted on the top and on the side of the sphere to allow the controlled movement of the device in all directions. Optionally, more or less propellers **2053** may be mounted on the device. Optionally, the one or more propellers **2053** may be mounted in different locations on the device. Control of the movement of the untethered device **2052** may be completely self-

contained or controlled wirelessly by an external user. As shown, the untethered device **2052** contains an energy source **2054**, control circuitry, **2055**, a sensor **2056**, and a power source **2057**. The energy source **2054** may be an optical energy source, an x-ray energy source, a particle beam energy source, or a combination thereof. The untethered device **2052** moves through a lumen **2042** scanning the surface of the lumen or cells flowing in the lumen with electromagnetic energy **2029** (optionally the same as **111**) sufficient to induce autofluorescence associated with a pathogen or pathological cell or tissue. Once autofluorescence is detected by the sensor **2056**, the untethered device **2052** emits energy sufficient to ablate the pathogen or pathological tissue.

[**0250**] FIG. **37** shows an illustrative configuration of an untethered device **2058** with controlled locomotion for the detection and ablation of pathogens and pathological tissue in a lumen **2042**. In this configuration, the two halves of the untethered device **2058** have grooves **2059** cut in opposite directions. The two halves of the untethered device **2058** rotate independently in opposite directions. Control of the movement of the untethered device **2058** may be completely self-contained or controlled wirelessly by an external user. Each half of the untethered device may have the independent capability of emitting and detecting a beam of energy **2006** sufficient to detect and ablate pathogens or pathological tissue.

[**0251**] FIG. **38** and FIG. **39** show illustrative configurations of untethered versions of an apparatus **100** with random movement for the detection and ablation of pathogens and pathological tissue in a lumen associated with, for example, the circulatory system, the gastrointestinal tract, the respiratory tract, or the urogenital tract.

[**0252**] FIG. **38** shows an illustrative configuration of an untethered device **2060** with random movement for the detection and ablation of pathogens and pathological tissue in a lumen. In this configuration, the untethered device **2060** is a sphere. Optionally, the untethered device **2060** may be any configuration that is compatible with housing the components necessary for detection and ablation of pathogens or pathological tissue in a lumen **2042**. The untethered device **2060** has one or more controllable arms **2061** attached to the surface. A paddle **2062** is attached to the end of each controllable arm **2061**. The one or more arms **2061** may move in varied directions relative to the surface of the untethered device and as such, randomly turn the untethered device **2060**. Control of the movement of the arms **2061** of the untethered device **2060** may be completely self-contained or controlled wirelessly by an external user. The untethered device **2060** randomly rotates based on the motion of the arms **2061** and associated paddles **2062**, scanning the surface of a lumen **2042** with a beam of energy **2006** sufficient to induce autofluorescence. Once autofluorescence associated with a pathogen or pathological tissue is detected, the untethered device **2060** emits energy sufficient to ablate the pathogen or pathological tissue.

[**0253**] FIG. **39** shows an illustrative configuration of an untethered device **2063** with random movement for the detection and ablation of pathogens and pathological tissue in a lumen. In this configuration, the untethered device **2063** is a sphere with two or more tracks **2064** within the interior of the sphere. Each track **2064** has at least one associated

weighted bead **2065** that is propelled along the track **2064**. Differential movement of the weighted beads will cause random rotation of the untethered device **2063**. The untethered device **2063** randomly rotates based on the motion of the two or more weighted beads, scanning the surface of a lumen **2042** with a beam of energy **2006**, optionally electromagnetic energy **2029** from a detection and ablation unit **2047** sufficient to induce autofluorescence. Once autofluorescence associated with a pathogen or pathological tissue is detected, the untethered device **2063** emits a beam of energy **2006** from the detection and ablation unit **2047** sufficient to ablate the pathogen or pathological tissue.

[**0254**] FIG. **40** shows an illustrative configuration of an untethered ingestible device **2066** for the detection and ablation of pathogens and pathological tissue in the lumen of the gastrointestinal tract **2067**. In the configuration shown, the untethered ingestible device is a sphere with multiple openings **2068** covering the surface of the sphere. The multiple openings **2068** may emit electromagnetic energy **2029** sufficient to induce autofluorescence of a pathogen or pathological tissue and/or pathogen cell death. The emitted autofluorescence **2070** induced by the electromagnetic energy **2029** is detected through one or more of the multiple openings **2068**. Once autofluorescence associated with a pathogen or pathological tissue is detected, the untethered ingestible device **2066** emits energy sufficient to ablate the pathogen or pathological tissue.

[**0255**] In one aspect, the disclosure is drawn to systems implementations including methods, computer programs, and systems for controlling optionally the detection and ablation and/or movement of targets optionally at least partially based on a fluorescent response. One or more of these systems implementations may be used as part of one or more methods for optionally detecting and ablating one or more targets optionally at least partially based on a fluorescent response, and/or implemented on one or more apparatus **100** and/or **500** and/or devices **200**, **300**, and/or **400** optionally configured to detect and/or to ablate one or more target cells. One or more of the operations, computer programs, and/or systems implementations described in association with one or more embodiments are envisioned and intended to also make part of other embodiments unless context indicates otherwise.

[**0256**] The operational flows may also be executed in a variety of other contexts and environments, and or in modified versions of those described herein. In addition, although some of the operational flows are presented in sequence, the various operations may be performed in various repetitions, concurrently, and/or in other orders than those that are illustrated. Although several operational flow sequences are described separately herein, these operational flows may be performed in sequence, in various repetitions, concurrently, and in a variety of orders not specifically illustrated herein. In addition, one or more of the steps described for one or more operational flow sequence may be added to another flow sequence and/or used to replace one or more steps in the flow sequence, with or without deletion of one or more steps of the flow sequence.

[**0257**] Operations may be performed with respect to a digital representation (e.g. digital data) of, for example, one or more characteristics of a fluorescent response, one or more characteristics of excitation energy **116**, one or more

characteristics of ablation energy **117**, one or more movement parameters, and/or one or more targeting parameters. The logic may accept a digital or analog (for conversion into digital) representation of an input and/or provide a digitally-encoded representation of a graphical illustration, where the input may be implemented and/or accessed locally or remotely. The logic may provide a digital representation of an output, wherein the output may be sent and/or accessed locally or remotely.

[**0258**] Operations may be performed related to either a local or a remote storage of the digital data, or to another type of transmission of the digital data. In addition to inputting, accessing querying, recalling, calculating, determining or otherwise obtaining the digital data, operations may be performed related to storing, assigning, associating, displaying or otherwise archiving the digital data to a memory, including for example, sending, outputting, and/or receiving a transmission of the digital data from (and/or to) a remote memory and/or unit, device, or apparatus. Accordingly, any such operations may involve elements including at least an operator (e.g. human or computer) directing the operation, a transmitting computer, and/or receiving computer, and should be understood to occur in the United States as long as at least one of these elements resides in the United States.

[**0259**] FIG. **8** and/or FIG. **9** depict embodiments of an operational flow **600** representing illustrative embodiments of operations related to providing a first output to a first energy source in real time, the first output providing data associated with at least partial ablation of a target at least partially based on the first possible dataset. In FIG. **8** and/or FIG. **9**, discussion and explanation may be provided with respect to one or more apparatus **100** and/or **500** and/or device **200**, **300** and/or **400** and methods described herein, and/or with respect to other examples and contexts.

[**0260**] In some embodiments, one or more methods include receiving a first input associated with a first possible dataset, the first possible dataset including data representative of a target fluorescent response; and providing a first output to a first energy source in real time, the first output providing data associated with at least partial ablation of a target at least partially based on the first possible dataset.

[**0261**] In illustrative embodiments, operational flow **600** may be employed in the process of target ablation to receive information associated with a target fluorescent response optionally from one or more apparatus **100** and/or **500** and/or devices **200**, **300**, and/or **400**, optionally including, but not limited to, information relating to the wavelength, intensity, strength, directionality, and/or spatial extent of the fluorescent response. In illustrative embodiments, operational flow **600** may be employed in the process of target ablation to analyze information associated with a target fluorescent response, optionally from one or more apparatus **100** and/or **500** and/or devices **200**, **300**, and/or **400**, to determine one or more characteristics of one or more energy source **110** and/or ablation energy **117** associated with at least partially ablating one or more target.

[**0262**] After a start operation, the operational flow **600** moves to a receiving operation **160**, receiving a first input associated with a first possible dataset, the first possible dataset including data representative of one or more target fluorescent response. For example, a first input may include,

but is not limited to, data representative of one or more wavelengths of excitation energy, direction, pulse time, timing, as well as detection wavelengths and timing. For example, a first input may include, but is not limited to, a condition, an illness, a cell and/or tissue type under investigation, and/or other disease and/or preventive medicine information

[0263] An optional accessing operation **260** accesses the first possible dataset in response to the first input. For example, data representative of one or more fluorescent responses, one or more autofluorescent responses, and/or one or more target fluorescent responses may be accessed. For example, data representative of background fluorescence, fluorescent tags and/or markers, and/or limits of detection may be accessed.

[0264] An optional generating operation **360** generates the first possible dataset in response to the first input. For example, data representative of one or more target fluorescent response may be generated optionally by eliminating and/or controlling for endogenous non-target fluorescence and/or non-specific fluorescence. For example, data representative of direction and/or location of a target, the presence or absence of a target, and/or the risk to non-target cells and tissues of ablation may be generated.

[0265] An optional determining operation **460** determines a graphical illustration of the first possible dataset. For example, data representative of one or more fluorescent responses, one or more autofluorescent responses, and/or one or more target fluorescent response may be graphically represented. For example, data representative of direction and/or location of a target optionally in relation to other non-target areas and/or the likelihood of collateral damage may be graphically represented.

[0266] An optional sending operation **560** sends the first output associated with the first possible dataset. For example, data representative of one or more fluorescent responses, one or more autofluorescent responses, and/or one or more target fluorescent response may be sent as part of the first output. For example, data representative of direction and/or location of a target may be sent optionally to an external source and/or to an ablation device.

[0267] An optional determining operation **660** determines data representative of one or more characteristics of excitation energy **116** for inducing the target fluorescent response. For example, data representative of one or more characteristics of excitation energy **116**, optionally including, but not limited to, wavelength, strength, mode, directionality, and/or spatial limitations may be determined.

[0268] An optional determining operation **760** determines data representative of one or more characteristics of ablation energy **117** for at least partially ablating a target. For example, data representative of one or more characteristics of ablation energy **117**, optionally including, but not limited to, wavelength, strength, mode, directionality, and/or spatial limitations may be determined.

[0269] An optional operation **860** includes an optional receiving operation **862** and an optional determining operation **864**. The optional receiving operation **862** receives a second input associated with a second possible dataset, the second possible dataset including data representative of a second target fluorescent response following the at least

partial ablation of the target. The optional determining operation **864** determines data representative of one or more characteristics of ablation energy **117** for further ablating a target at least partially based on the second possible dataset. For example, data representative of a second target fluorescent response may include one or more characteristics different from the first, previous and/or original target fluorescent response, optionally as a result of the at least partial ablation of the target. For example, the one or more characteristics may include, but are not limited to, presence, absence and/or reduction in the target fluorescent response.

[0270] An optional operation **960** includes an optional receiving operation **962** and an optional determining operation **964**. The optional receiving operation **962** receives a third input associated with a third possible dataset, the third possible dataset including data representative of a fluorescent response. The optional determining operation **964** determines data representative of one or more characteristics of excitation energy **116** for inducing a target fluorescent response at least partially based on the third possible dataset. For example, data representative of a fluorescent response may indicate the presence or absence of a target fluorescent response.

[0271] Then, a providing operation **1060**, provides a first output to a first energy source in real time, the first output providing data associated with at least partial ablation of a target at least partially based on the first possible dataset. For example, data representative of one or more characteristics of ablation energy **117**, one or more characteristics of the excitation energy **116**, one or more characteristics of the fluorescent response, one or more environmental parameters, and/or one or more targeting parameters.

[0272] FIG. **10** and/or FIG. **11** depict embodiments of an operational flow **700** representing illustrative embodiments of operations related to providing a first output to a first energy source in real time, the first output providing data representative of one or more ablation characteristics for at least partially ablating a target area. In FIG. **10** and/or FIG. **11**, discussion and explanation may be provided with respect to one or more apparatus **100** and/or **500** and/or device **200**, **300** and/or **400** and methods described herein, and/or with respect to other examples and contexts.

[0273] In some embodiments, one or more methods include receiving a first input associated with a first possible dataset, the first possible dataset including data representative of a target fluorescent response; determining data representative of a location of a target area at least partially based on the first possible dataset; and providing a first output to a first energy source in real time, the first output providing data representative of one or more ablation characteristics for at least partially ablating the target area.

[0274] In illustrative embodiments, operational flow **700** may be employed in the process of target ablation to receive information associated with a target fluorescent response optionally from one or more apparatus **100** and/or **500** and/or devices **200**, **300**, and/or **400**, optionally including, but not limited to, information relating to the wavelength, intensity, strength, directionality, and/or spatial extent of the fluorescent response. In illustrative embodiments, operational flow **700** may be employed in the process of target ablation to analyze information associated with a target fluorescent response to determine data associated with the

location of a target and one or more characteristics of one or more energy source **110** and/or ablation energy **117** associated with at least partially ablating one or more target.

[0275] After a start operation, the operational flow **700** moves to a receiving operation **170**, receiving a first input associated with a first possible dataset, the first possible dataset including data representative of one or more target fluorescent response. For example, a first input may include, but is not limited to, data representative of one or more wavelengths of excitation energy, direction, pulse time, timing, as well as detection wavelengths and timing. For example, a first input may include, but is not limited to, a condition, an illness, a cell and/or tissue type under investigation, and/or other disease and/or preventive medicine information

[0276] An optional accessing operation **270** accesses the first possible dataset in response to the first input. For example, data representative of one or more fluorescent responses, one or more autofluorescent responses, and/or one or more target fluorescent responses may be accessed. For example, data representative of background fluorescence, fluorescent tags and/or markers, and/or limits of detection may be accessed.

[0277] An optional generating operation **370** generates the first possible dataset in response to the first input. For example, data representative of one or more target fluorescent response may be generated optionally by eliminating and/or controlling for endogenous non-target fluorescence and/or non-specific fluorescence. For example, data representative of emissions as a function of wavelength in relation to time and/or distance may be generated.

[0278] An optional determining operation **470** determines a graphical illustration of the first possible dataset. For example, data representative of one or more fluorescent responses, one or more autofluorescent responses, and/or one or more target fluorescent response may be graphically represented. For example, data representative of possible results associated with (and/or corresponding to) one or more possible ablation parameters, optionally including use of particle beam and/or electromagnetic energy for target ablation, optionally in relation to other non-target areas and/or the likelihood of collateral damage may be graphically represented.

[0279] An optional determining operation **570** determining data representative of a location of one or more target area at least partially based on the first possible dataset. For example, data representative of a location of one or more target area may include, but is not limited to, direction, spatial extent, environment, and/or depth, optionally in relation to one or more excitation energy source **116**, one or more targeting energy source **118**, and/or one or more ablation energy source **117**.

[0280] An optional sending operation **670** sends the first output associated with the first possible dataset optionally to the first energy source, optionally the ablation energy source **117**. For example, data representative of one or more target fluorescent response, one or more characteristics of ablation energy **117**, and/or one or more targeting parameters may be sent as part of the first output.

[0281] An optional determining operation **770** determines data representative of one or more characteristics of exci-

tation energy **116** for inducing the target fluorescent response. For example, data representative of one or more characteristics of excitation energy **116**, optionally including, but not limited to, wavelength, strength, mode, directionality, and/or spatial limitations may be determined.

[0282] An optional determining operation **870** determines data representative of one or more characteristics of ablation energy **117** for at least partially ablating a target. For example, data representative of one or more characteristics of ablation energy **117**, optionally including, but not limited to, wavelength, strength, mode, directionality, and/or spatial limitations may be determined.

[0283] An optional operation **970** includes an optional receiving operation **972** and an optional determining operation **974**. The optional receiving operation **972** receives a second input associated with a second possible dataset, the second possible dataset including data representative of a second target fluorescent response following the at least partial ablation of the target. The optional determining operation **974** determines data representative of one or more characteristics of ablation energy **117** for further ablating a target at least partially based on the second possible dataset. For example, data representative of a second target fluorescent response may include one or more characteristics different from the first, previous and/or original target fluorescent response, optionally as a result of the at least partial ablation of the target. For example, the one or more characteristics may include, but are not limited to, presence, absence and/or extent of reduction in the target fluorescent response.

[0284] An optional operation **1070** includes an optional receiving operation **1072** and an optional determining operation **1074**. The optional receiving operation **1072** receives a third input associated with a third possible dataset, the third possible dataset including data representative of a fluorescent response. The optional determining operation **1074** determines data representative of one or more characteristics of excitation energy **116** for inducing a target fluorescent response at least partially based on the third possible dataset. For example, data representative of a fluorescent response may indicate the presence, absence, or extent of reduction of a target fluorescent response.

[0285] Then, a providing operation **1170**, provides a first output to a first energy source in real time, the first output providing data representative of one or more ablation characteristics for at least partially ablating the target area. For example, data representative of one or more characteristics of ablation energy **117**, one or more characteristics of the excitation energy **116**, one or more characteristics of the fluorescent response, one or more environmental parameters, and/or one or more targeting parameters.

[0286] FIG. 12 and/or FIG. 13 depict embodiments of an operational flow **800** representing illustrative embodiments of operations related to providing a first possible output to a first motive source, the first possible output providing data representative of one or more parameters associated with movement of an untethered device in a lumen at least partially based on the location of the target area. In FIG. 12 and/or FIG. 13, discussion and explanation may be provided with respect to one or more device **200** and/or **300** and methods described herein, and/or with respect to other examples and contexts.

[0287] In some embodiments, one or more methods include receiving a first input associated with a first possible dataset, the first possible dataset including data representative of a fluorescent response; determining data representative of a location of a target area at least partially based on the first possible dataset; and providing a first possible output to a first motive source, the first possible output providing data representative of one or more parameters associated with movement of an untethered device in a lumen at least partially based on the location of the target area.

[0288] In illustrative embodiments, operational flow 800 may be employed in the process of moving an untethered device in a lumen, optionally associated with target ablation, to receive information associated with a fluorescent response optionally from one or more devices 200 and/or 300, optionally including, but not limited to, information relating to the wavelength, intensity, strength, directionality, and/or spatial extent of the fluorescent response. In illustrative embodiments, operational flow 800 may be employed in the process of moving an untethered device in a lumen to analyze information associated with a target fluorescent response to determine data associated with the location of a target and one or more characteristics of one or more power source 140 and/or motive force, optionally associated with at least partially ablating one or more target.

[0289] After a start operation, the operational flow 800 moves to a receiving operation 180, receiving a first input associated with a first possible dataset, the first possible dataset including data representative of one or more fluorescent response. For example, data representative of one or more fluorescent response may include, but is not limited to, data representative of a target fluorescent response, a non-target fluorescent response, and/or a autofluorescent response. For example, a first input may include, but is not limited to, one or more characteristics of excitation energy, one or more characteristics of targeting energy, and/or one or more characteristics of ablation energy.

[0290] An optional accessing operation 280 accesses the first possible dataset in response to the first input. For example, data representative of one or more fluorescent responses, optionally data representative of one or more target fluorescent response and/or one or more autofluorescent response, may be accessed. For example, data representative of the presence and/or absence of a target fluorescent response and/or presence or absence of other non-target fluorescent responses may be accessed.

[0291] An optional generating operation 380 generates the first possible dataset in response to the first input. For example, data representative of one or more target fluorescent response may be generated optionally based on calculations associated with background fluorescent, signal to noise ratios, non-specific fluorescence, and/or endogenous non-target autofluorescence. For example, data representative of a location of a target area determined at least partially based on the fluorescent response may also be generated.

[0292] An optional determining operation 480 determines a graphical illustration of the first possible dataset. For example, data representative of one or more target fluorescent response may be graphically represented. For example, data representative of a location of one or more target area optionally in relation to the current device location may be

graphically represented. For example, data representative of one or more parameters associated with the movement of the untethered device associated with target ablation and/or target detection may be determined and/or generated.

[0293] A determining operation 580 determines data representative of a location of one or more target area at least partially based on the first possible dataset. For example, data representative of a location of one or more target area may include, but is not limited to, direction, spatial extent, environment, and/or depth, optionally in relation to one or more excitation energy source 116, one or more targeting energy source 118, and/or one or more ablation energy source 117. For example, data representative of a location of one or more target area may include, but is not limited to, one or more characteristics associated with movement of an untethered device for target ablation and/or target detection.

[0294] An optional generating operation 680 generates the first possible output in response to the first input. For example, a first possible output may include data representative of a location of one or more target area at least partially based on the first possible dataset. For example, a first possible output may include, but is not limited to, data representative of a direction of movement, a rate of movement, a speed of movement, a time of movement, a mechanism of movement, and/or a power source.

[0295] An optional sending operation 780 sends the first output associated with the first possible dataset optionally to a motive source 150 and/or a power source 140. For example, data representative of a direction of movement, a rate of movement, a speed of movement, a time of movement, a mechanism of movement, and/or a power source may be sent as part of the first output.

[0296] An optional determining operation 880 determines data representative of one or more characteristics of excitation energy 116 for inducing the fluorescent response. For example, data representative of one or more characteristics of excitation energy 116, optionally including, but not limited to, wavelength, strength, mode, directionality, and/or spatial limitations may be determined.

[0297] An optional determining operation 980 determines data representative of one or more characteristics of ablation energy 117 for at least partially ablating a target. For example, data representative of one or more characteristics of ablation energy 117, optionally including, but not limited to, wavelength, strength, mode, directionality, and/or spatial limitations may be determined.

[0298] Then, a providing operation 1080, provides a first possible output to a first motive source, the first possible output providing data representative of one or more parameters associated with movement of an untethered device in a lumen at least partially based on the location of the target area. For example, data representative of one or more characteristics of ablation energy 117, one or more characteristics of the excitation energy 116, one or more characteristics of the fluorescent response, one or more environmental parameters, and/or one or more targeting parameters.

[0299] The following include illustrative embodiments of one or more operations of operational flow 600, operational flow 700 and/or operational flow 800.

[0300] In illustrative embodiments, a target fluorescent response is optionally an auto-fluorescent response and/or elicited from one or more extrinsically provided markers.

[0301] In illustrative embodiments, a first input is from a sensor configured to detect one or more of a target fluorescent response, a fluorescent response, and/or an autofluorescent response. In illustrative embodiments, a first input is from one or more external sources, optionally remotely, programmably, and/or wirelessly received. The one or more external sources may include, but are not limited to, sensors, control circuitry, databases, and/or user interfaces.

[0302] In illustrative embodiments, a first input includes data representative of one or more measurements of electromagnetic energy. One or more measurements of electromagnetic energy optionally include, but are not limited to, one or more measurements of one or more wavelengths of the electromagnetic energy and/or measurements of an extended-spectrum of the electromagnetic energy. One or more measurements of electromagnetic energy optionally include, but are not limited to, measurements over a cumulative time interval and/or time dependent electromagnetic energy measurements. One or more time dependent measurements may include, but are not limited to, measurements at one or more times and/or measurements at one or more time intervals following excitation of a fluorescent response. One or more measurements of electromagnetic energy optionally include, but are not limited to, one or more measurements of the location of the source and/or incidence of electromagnetic energy (e.g. a fluorescent response, excitation energy **116**, ablation energy **117**, and/or targeting energy **118**). One or more measurements of the location of the source and/or incidence of electromagnetic energy include, but are not limited to, one or more measurements of a direction of incidence electromagnetic energy, and/or one or more measurements of a tissue depth of incidence electromagnetic energy. One or more measurements of electromagnetic energy optionally include, but are not limited to, one or more measurements of a strength of the electromagnetic energy.

[0303] In illustrative embodiments, a first input includes data representative of one or more characteristics of one or more targets and/or one or more diseases and/or disorders. In illustrative embodiments, a first input includes data representative of the target fluorescent response. Data representative of the target fluorescent response may include, but is not limited to, one or more measurements of electromagnetic energy, and/or one or more measurements of one or more temporal-spatial locations of the target fluorescent response. As used herein, the term “temporal-spatial locations” may include one or more temporal locations and/or one or more spatial locations. Data representative of a target fluorescent response may include, but is not limited to, a clustering of fluorescent responses that would otherwise be considered a normal response in the absence of clustering, or with limited clustering, or non-significant clustering. In illustrative embodiments, clustering might include cells forming a plaque, bacterial cells forming a colony, blood cells forming a clot, malaria-infected red blood cells aggregating, among others.

[0304] In illustrative embodiments, a first possible dataset includes data representative of one or more fluorescence characteristics of one or more possible constituents of the target area. As used herein, the term “constituents” may include, but is not limited to, cells, tissues, lumen, proteins, plaques, membranes, pathogens, microorganisms, and/or parasites, among others.

[0305] In illustrative embodiments, a first possible dataset includes data representative of one or more numerical measurements for one or more possible constituents of the target area. One or more numerical measurements may include, but are not limited to, one or more numerical measurements for normal levels of one or more possible constituents of the target area and/or for abnormal levels of one or more possible constituents of the target area.

[0306] In illustrative embodiments, a first possible dataset includes data representative of excitation energy **116**. Data representative of excitation energy **116** includes, but is not limited to, data representative of one or more characteristics of excitation energy **116**. Data representative of one or more characteristics of excitation energy **116** include, but are not limited to, strength of the excitation energy, one or more wavelengths of the excitation energy, one or more spatial parameters of the excitation energy, and/or one or more directional parameters of the excitation energy. One or more spatial parameters of the excitation energy include, but are not limited to, one or more spatial limitations of the excitation energy, optionally including, but not limited to, spatially focused and spatially collimated. One or more directional parameters of the excitation energy include, but are not limited to, directionally limited, directionally varied and directionally variable.

[0307] One or more characteristics of the excitation energy include, but are not limited to, manual, programmable, automatic, remote-controlled, and feedback-control. In illustrative embodiments, for example, subsequent excitation energy characteristics may be determined based on one or more characteristics of the fluorescent emissions associated with the characteristics of the previous excitation energy selected. For example, if the previous excitation energy induced a fluorescent response with high background and/or non-specific emissions, or without a target signal, a different excitation energy might be selected. In illustrative embodiments, for example, excitation energy may be at least partially determined by the location, and/or as a result of a prior ablation.

[0308] In illustrative embodiments, a first possible dataset includes data representative of ablation energy **117**. Data representative of ablation energy **117** optionally includes, but is not limited to data representative of one or more characteristics of the ablation energy **117**. One or more characteristics of the ablation energy include, but are not limited to, strength of the ablation energy, one or more wavelengths of the ablation energy, one or more spatial parameters of the ablation energy, and/or one or more directional parameters of the ablation energy. One or more spatial parameters of the ablation energy include, but are not limited to, one or more spatial limitations of the ablation energy, optionally including, but not limited to, spatially focused and spatially collimated. One or more directional parameters of the ablation energy include, but are not limited to, directionally limited, directionally varied and directionally variable.

[0309] One or more characteristics of the ablation energy include, but are not limited to, manual, programmable, automatic, remote-controlled, and feedback-controlled. One or more characteristics of the ablation energy include, but are not limited to, the minimum energy associated with at least partially ablating one or more target areas and/or one

or more non-target areas. One or more characteristics of the ablation energy include, but are not limited to, the one or more characteristics of the optimum energy associated with at least partially ablating one or more target areas while minimizing and/or reducing the ablation of one or more non-target areas (e.g. reducing collateral damage). In illustrative embodiments, one or more characteristics of ablation energy may be determined based on detection of only partial ablation from a prior ablation.

[0310] In some embodiments, ablation energy 117 is one or more of charged particles (e.g. from a particle beam) 112 or electromagnetic energy 111. In some embodiments, particle beam energy 112 may include, but is not limited to, electrons, protons, alpha particles, beta particles and/or gamma particles. In some embodiments, electromagnetic energy 111 may include, but is not limited to, optical energy 113 and/or X-ray 115 energy. In some embodiments, ablation energy 117 is pulsed energy.

[0311] In illustrative embodiments of a receiving operation 160, 170, and/or 180, receiving a first input associated with a first possible dataset includes, but is not limited to, receiving a first data entry associated with the first possible dataset. In illustrative embodiments, a first data entry may include, but is not limited to, one or more measurements of energy (optionally electromagnetic energy) and/or one or more measurements of one or more temporal-spatial locations of a fluorescent response (e.g. a target fluorescent response). In illustrative embodiments, a first data entry may include, but is not limited to, data representative of one or more characteristics of one or more targets, one or more diseases, and/or one or more disorders.

[0312] In illustrative embodiments of a receiving operation 160, 170, and/or 180, receiving a first input associated with a first possible dataset includes, but is not limited to, receiving a first data entry from a sensor, from a database, and/or from a user interface (e.g. from at least one submission element of a graphical user interface).

[0313] In illustrative embodiments of a receiving operation 160, 170, and/or 180, receiving a first input associated with a first possible dataset includes, but is not limited to, receiving a first data entry at least partially identifying one or more elements of the first possible dataset. In illustrative embodiments, one or more elements of the first possible dataset include one or more of one or more measurements of electromagnetic energy, one or more measurements of one or more temporal-spatial locations of a target fluorescent response, data representative of excitation energy, and/or data representative of ablation energy 117.

[0314] In illustrative embodiments of a receiving operation 160, 170, and/or 180, receiving a first input associated with a first possible dataset includes, but is not limited to, receiving a first request associated with the first possible dataset. In illustrative embodiments, the first request includes, but is not limited to, selecting and/or determining data representative of one or more measurements of electromagnetic energy, data representative of one or more measurements of one or more temporal-spatial locations of the target fluorescent response, and/or data representative of one or more characteristics of ablation energy.

[0315] In illustrative embodiments of a receiving operation 160, 170, and/or 180, receiving a first input associated

with a first possible dataset includes, but is not limited to, receiving a first request from a user interface (e.g. at least one submission element of a graphical user interface). In illustrative embodiments, the first request at least partially identifies and/or selects one or more elements of the first possible dataset. In illustrative embodiments, the first request provides instructions identifying, specifying, and/or determining data representative of one or more elements of the first possible dataset.

[0316] In illustrative embodiments of an optional accessing operation 260, 270, and/or 280 accessing the first possible dataset in response to the first input includes, but is not limited to, accessing the first possible dataset using a database management system engine. In some embodiments, the database management system engine is configured to query a first database to retrieve the first possible dataset therefrom. In illustrative embodiments, accessing the first possible dataset in response to the first input includes, but is not limited to, accessing the first possible dataset by querying a first database to retrieve data representative of one or more characteristics of one or more targets associated with one or more diseases and/or disorders.

[0317] In illustrative embodiments of an optional accessing operation 260, 270, and/or 280 accessing the first possible dataset in response to the first input includes, but is not limited to, accessing the first possible dataset from within a first database associated with a plurality of measurements of electromagnetic energy, a plurality of measurements of one or more temporal-spatial locations of the target fluorescent response, and/or a plurality of characteristics of ablation energy.

[0318] In illustrative embodiments of an optional accessing operation 260, 270, and/or 280 accessing the first possible dataset in response to the first input includes, but is not limited to, accessing the first possible dataset by associating data representative of one or more measurements of electromagnetic energy, data representative of one or more temporal-spatial locations of the target fluorescent response, and/or data representative of one or more characteristics of ablation energy with one or more elements of the first possible dataset.

[0319] In illustrative embodiments of an accessing operation 260, 270, and/or 280 accessing the first possible dataset in response to the first input includes, but is not limited to, accessing the first possible dataset by corresponding data representative of one or more measurements of electromagnetic energy, data representative of one or more temporal-spatial locations of the target fluorescent response, and/or data representative of one or more characteristics of ablation energy with one or more elements of the first possible dataset.

[0320] In illustrative embodiments of an accessing operation 260, 270, and/or 280 accessing the first possible dataset in response to the first input includes, but is not limited to, accessing the first possible dataset as being associated with data representative one or more measurements of electromagnetic energy, data representative of one or more measurements of one or more temporal-spatial locations of the target fluorescent response, and/or data representative of one or more characteristics of ablation energy.

[0321] In illustrative embodiments of an optional generating operation 360, 370, and/or 380, generating the first

possible dataset in response to the first input includes, but is not limited to, generating the first possible dataset using a database management system engine. In illustrative embodiments, generating the first possible dataset in response to the first input includes, but is not limited to, generating the first possible dataset using a database management system engine to retrieve data representative of one or more characteristics of one or more targets associated with one or more diseases and/or disorders.

[0322] In illustrative embodiments of an optional generating operation 360, 370, and/or 380, generating the first possible dataset in response to the first input includes, but is not limited to, generating the first possible dataset by corresponding and/or associating data representative of one or more measurements of electromagnetic energy, data representative of one or more measurements of temporal-spatial locations of the target fluorescent response, and/or data representative of one or more characteristics of ablation energy with one or more elements of the first possible dataset.

[0323] In illustrative embodiments of an optional generating operation 360, 370, and/or 380, generating the first possible dataset in response to the first input includes, but is not limited to, receiving a first request associated with the first possible dataset; and generating the first possible dataset in response to the first request, the first request specifying data representative of one or more measurements of electromagnetic energy, data representative of one or more measurements of one or more temporal-spatial locations of the target fluorescent response and/or data representative of one or more characteristics of ablation energy. In illustrative embodiments, the first request specifies one or more characteristics of one or more targets.

[0324] In illustrative embodiments of an optional generating operation 360, 370, and/or 380, generating the first possible dataset in response to the first input includes, but is not limited to, receiving a first request, the first request specifying data representative of one or more measurements of electromagnetic energy; and generating the first possible dataset in response to the first request at least partially by performing an analysis of data representative of one or more measurements of one or more temporal-spatial locations of the target fluorescent response.

[0325] In illustrative embodiments of an optional generating operation 360, 370, and/or 380, generating the first possible dataset in response to the first input includes, but is not limited to, receiving a first request, the first request specifying data representative of one or more measurements of one or more temporal-spatial locations of the target fluorescent response; and generating the first possible dataset in response to the first request at least partially by performing an analysis of data representative of one or more measurements of electromagnetic energy.

[0326] In illustrative embodiments of an optional generating operation 360, 370, and/or 380, generating the first possible dataset in response to the first input includes, but is not limited to, receiving a first request, the first request specifying data representative of one or more characteristics of ablation energy; and generating the first possible dataset in response to the first request at least partially by performing an analysis of data representative of one or more measurements of electromagnetic energy.

[0327] In illustrative embodiments of an optional generating operation 360, 370, and/or 380, generating the first possible dataset in response to the first input includes, but is not limited to, receiving a first request, the first request specifying data representative of one or more characteristics of ablation energy; and generating the first possible dataset in response to the first request at least partially by performing an analysis of data representative one or more measurements of one or more temporal-spatial locations of the target fluorescent response.

[0328] In illustrative embodiments of an optional determining operation 460, 470, and/or 480, determining a graphical illustration of the first possible dataset includes, but is not limited to, determining the graphical illustration of the first possible dataset for inclusion in a display element of a graphical user interface. In illustrative embodiments, determining a graphical illustration of the first possible dataset includes, but is not limited to, determining a graphical illustration of data representative of one or more characteristics of one or more targets associated with one or more diseases and/or disorders.

[0329] In illustrative embodiments of an optional determining operation 460, 470, and/or 480, determining a graphical illustration of the first possible dataset includes, but is not limited to, performing an analysis of one or more elements of the first possible dataset to determine the location of the target area; and determining the graphical illustration based on the analysis.

[0330] In illustrative embodiments of an optional determining operation 460, 470, and/or 480, determining a graphical illustration of the first possible dataset includes, but is not limited to, performing an analysis of one or more elements of the first possible dataset to determine the location of the target area; and determining the graphical illustration including data representative of one or more measurements of electromagnetic energy, data representative of one or more measurements of one or more temporal-spatial locations of the target fluorescent response, and/or data representative of one or more characteristics of ablation energy in association with a visual indicator related to the location of the target area.

[0331] In illustrative embodiments of an optional determining operation 460, 470, and/or 480, determining a graphical illustration of the first possible dataset includes, but is not limited to, performing an analysis of one or more elements of the first possible dataset to determine a first possible outcome; and determining the graphical illustration based on the analysis. In illustrative embodiments, the first possible outcome optionally includes, but is not limited to, one or more of a possible risk, a possible result, or a possible consequence.

[0332] In illustrative embodiments of an optional determining operation 460, 470, and/or 480, determining a graphical illustration of the first possible dataset includes, but is not limited to, performing an analysis of one or more elements of the first possible dataset to determine a first possible outcome; and determining the graphical illustration including data representative of one or more measurements of electromagnetic energy, data representative of one or more measurements of one or more temporal-spatial locations of the target fluorescent response, and/or data repre-

sentative of one or more characteristics of ablation energy in association with a visual indicator related to the first possible outcome.

[0333] In illustrative embodiments of an optional determining operation 460, 470, and/or 480, determining a graphical illustration of the first possible dataset includes, but is not limited to, determining a correlation between a first possible outcome and a type or characteristic of a visual indicator used in the graphical illustration to represent the first possible outcome.

[0334] In illustrative embodiments of an optional determining operation 460, 470, and/or 480, determining a graphical illustration of the first possible dataset includes, but is not limited to, determining the graphical illustration of a first possible outcome based on use of ablation energy having one or more characteristics. A first possible outcome may include, but is not limited to, partial ablation, complete ablation, non-target partial ablation, and/or non-target complete ablation, among others.

[0335] In illustrative embodiments of a determining operation 570 and/or 580, determining data representative of a location of a target area at least partially based on the first possible dataset includes, but is not limited to, determining data representative of the location of the target area at least partially based on the first possible dataset, the first possible dataset including one or more measurements of electromagnetic energy, and/or one or more measurements of the target fluorescent response. In illustrative embodiments, determining data representative of a location of a target area at least partially based on the first possible dataset includes, but is not limited to, determining data representative of one or more characteristics of one or more targets associated with one or more diseases and/or disorders.

[0336] In illustrative embodiments of a determining operation 570 and/or 580, determining data representative of a location of a target area at least partially based on the first possible dataset includes, but is not limited to, performing an analysis of one or more elements of the first possible dataset; and determining data representative of the location of the target area at least partially based on the analysis. In illustrative embodiments, analysis of the first possible dataset may include a determination of coordinates for ablation, and/or a determination that one or more target locations are not within range of ablation energy, and/or a determination that ablation of one or more targets has a possibility of causing non-target damage.

[0337] In illustrative embodiments of a determining operation 570 and/or 580, determining data representative of a location of a target area at least partially based on the first possible dataset includes, but is not limited to, performing an analysis of one or more elements of the first possible dataset and at least one additional instruction; and determining data representative of the location of the target area at least partially based on the analysis.

[0338] In illustrative embodiments of an optional generating operation 680, generating the first possible output in response to the first input includes, but is not limited to, generating the first possible output at least partially based on information associated with the location of a target and movement of an untethered device associated with ablation. In illustrative embodiments, one or more target is identified,

optionally in a location too distant and/or obstructed for ablation and one or more parameters associated with movement of the untethered device to a location optionally to facilitate ablation are generated. In illustrative embodiments, no targets are identified in a particular location and one or more parameters associated with movement of the untethered device to another location optionally to facilitate further screening are generated.

[0339] In illustrative embodiments of an optional sending operation 560, 670, and/or 780, sending a first output associated with the first possible dataset includes, but is not limited to, sending a first output to one or more of a motive source 150, a power source 140, and/or an energy source 110, optionally an excitation energy source 116 and/or an ablation energy source 117. In some embodiments, sending a first output associated with the first possible dataset includes, but is not limited to, sending a first output to one or more external sources, optionally to one or more control circuitry 130, optionally in an external and/or remote location, that optionally provide a graphical illustration of the output, and/or that provide analysis and feedback at least partially based on the output.

[0340] In illustrative embodiments of an optional determining operation 660, 770, and/or 880, determining data representative of one or more characteristics of excitation energy 116 for inducing the target fluorescent response includes, but is not limited to, determining one or more characteristics of excitation energy 116 based at least partially on one or more of, but not limited to, the location of the lesion, the lumen, and/or the internal location, the environmental characteristics of the location, the distance, depth of tissue, and putative target, as well as the characteristics of the expected surrounding constituents.

[0341] In illustrative embodiments, one or more characteristics of the excitation energy 116 include, but are not limited to, one or more of strength of the excitation energy, wavelengths of the excitation energy, spatial parameters of the excitation energy, and/or directional parameters of the excitation energy. In some embodiments, one or more spatial parameters of the excitation energy include, but are not limited to, one or more spatial limitations of the excitation energy and/or a depth of focus of the excitation energy. In some embodiments, one or more spatial limitations include, but are not limited to, spatially focused and spatially collimated. In some embodiments, one or more characteristics of the depth of focus of the excitation energy includes, but are not limited to, a depth of focus is below a surface of a lesion, beyond a surface of a wall of a lumen, and/or beyond a surface of an internal location. In illustrative embodiments, a depth of focus is approximately 0.1 mm to 3 mm below a surface of a lesion, beyond a surface of a wall of a lumen, and/or beyond a surface of an internal location. In some embodiments, one or more directional parameters include, but are not limited to, directionally limited, directionally varied and directionally variable.

[0342] In illustrative embodiments, one or more characteristics of the excitation energy 116 include, but are not limited to, manual, programmable, automatic, remote-controlled, and feedback-controlled. In illustrative embodiments, a care-giver (physician, veterinarian, dentist, etc.) makes the final determination for ablation based on information determined by one or more program, and manually releases the programmably determined ablation energy.

[0343] In illustrative embodiments, excitation energy **116** is electromagnetic energy, optionally optical energy. In illustrative embodiments, excitation energy **116** is pulsed energy. In illustrative embodiments, excitation energy **116** is optionally single photon electromagnetic energy, two photon electromagnetic energy, multiple wavelength electromagnetic energy, and/or extended-spectrum electromagnetic energy. In some embodiments, two photon electromagnetic energy is coupled through a virtual energy level and/or through an intermediate energy level. In some embodiments, two photon electromagnetic energy is generated by two photons having the same wavelength or by two photons having a different wavelength.

[0344] In illustrative embodiments of an optional determining operation **760**, **870**, and/or **980**, determining data representative of one or more characteristics of ablation energy for at least partially ablating the target area includes, but is not limited to, assessing one or more characteristics of one or more constituents, assessing one or more characteristics of the target (e.g. location, size, depth, distance, etc.), and/or selecting one or more energy sources. In illustrative embodiments, the one or more characteristics of the ablation energy are selected to optimally ablate the target area while minimizing ablation outside the target area.

[0345] In illustrative embodiments, optional receiving and determining operations **860** and/or **970** include receiving a second input associated with a second possible dataset, the second possible dataset including data representative of a second target fluorescent response following at least partial ablation of the target area; and determining data representative of one or more characteristics of ablation energy for further ablating the target area at least partially based on the second possible dataset. In illustrative embodiments, excitation energy is optionally provided following at least partial ablation of one or more target optionally to determine the extent of ablation of target and/or non-target tissues and/or cells. Emission information detected by one or more sensor is optionally used to determine locations (optionally coordinates) for additional ablation, as necessary.

[0346] In illustrative embodiments, optional receiving and determining operations **960** and/or **1070** include receiving a third input associated with a third possible dataset, the third possible dataset including data representative of a fluorescent response; and determining data representative of one or more characteristics of excitation energy for inducing the target fluorescent response at least partially based on the third possible dataset. In illustrative embodiments, excitation energy of one or more characteristics may not elicit an identifiable and/or detectable target fluorescent response by the sensor. At least partially based on the lack of detection of a target fluorescent response (and the characteristics of the excitation energy released), characteristics of an additional excitation energy for release are selected, and optionally provided to the electromagnetic energy source **11**, optionally one or more excitation energy source **116**.

[0347] In illustrative embodiments of a providing operation **1060** and/or **1170**, providing a first output to a first energy source in real time includes, but is not limited to, sending the first output to the first energy source in real time.

[0348] In illustrative embodiments of a providing operation **1060** and/or **1170**, providing a first output to a first energy source in real time includes, but is not limited to,

sending a first instruction associated with the first possible dataset to the first energy source. In illustrative embodiments, the first instruction contains data representative of one or more measurements of electromagnetic energy, data representative of one or more measurements of target fluorescent energy, data representative of one or more characteristics of ablation energy, data representative of one or more characteristics of targeting energy, and/or data representative of the location of the target area to be at least partially ablated.

[0349] In illustrative embodiments of a providing operation **1060** and/or **1170**, providing a first output to a first energy source in real time includes, but is not limited to, sending the first output to the first targeting energy source in real time, the first output providing data representative of the one or more ablation characteristics for at least partially ablating the target area.

[0350] In illustrative embodiments, a first energy source **110** is an electromagnetic energy source **111**, optionally an optical energy source **113** and/or an X-ray energy source **115**. In some embodiments, the first energy source **110** is a laser. In illustrative embodiments, a first energy source **110** is a charged particle source **112** that optionally provides particles including, but not limited to, electrons, protons, alpha particles, beta particles, and/or gamma particles.

[0351] In illustrative embodiments, a first output includes data representative of one or more characteristics of ablation energy **117** for at least partially ablating the target area. In illustrative embodiments, ablation energy **117** is electromagnetic energy and/or charged particles. In illustrative embodiments, a first output includes targeting data for at least partially ablating the target area. In illustrative embodiments, a first output includes data representative of the location of the target area to be at least partially ablated.

[0352] In illustrative embodiments, a first targeting energy **118** has a different spatial irradiation extent than the first energy source **110**. In some embodiments, the first targeting energy source provides electromagnetic targeting energy, optionally optical targeting energy, optionally visual targeting energy.

[0353] In illustrative embodiments of a providing operation **1080**, providing a first output to a first motive source includes, but is not limited to, providing a first output to a first motive source in real time. In illustrative embodiments of a providing operation **1080**, providing a first output to a first motive source includes, but is not limited to, sending the first output to the first motive source optionally in real time.

[0354] The following provides a description of illustrative computer program products **1200**, **1300**, and/or **1400** based on one or more of the operational flows **600**, **700**, and/or **800** and variations thereof as described above. These computer program products may also be executed in a variety of other contexts and environments, and or in modified versions of those described herein. In addition, although some of the computer program products are presented in sequence, the various instructions may be performed in various repetitions, concurrently, and/or in other orders than those that are illustrated. Although instructions for several computer program products are described separately herein, these instructions may be performed in sequence, in various repetitions, concurrently, and in a variety of orders not specifically

illustrated herein. In addition, one or more of the instructions described for one or more computer program products may be added to another computer program product and/or used to replace one or more instructions in the computer program products, with or without deletion of one or more instructions of the computer program products.

[0355] FIG. 14 and FIG. 15 show a schematic of a partial view of an illustrative computer program product 1200 that includes a computer program for executing a computer process on a computing device. An illustrative embodiment of the illustrative computer program product is provided using a signal bearing medium 1210, and may include at least one of one or more instructions 1215 including: one or more instructions for receiving a first input associated with a first possible dataset, the first possible dataset including data representative of a target fluorescent response; one or more instructions for accessing the first possible dataset in response to the first input; one or more instructions for generating the first possible dataset in response to the first input; one or more instructions for determining a graphical illustration of the first possible dataset; one or more instructions for sending the first output associated with the first possible dataset; one or more instructions for determining data representative of one or more characteristics of excitation energy for inducing the target fluorescent response; one or more instructions for determining data representative of one or more characteristics of ablation energy for at least partially ablating a target; one or more instructions for receiving a second input associated with a second possible dataset, the second possible dataset including data representative of a second target fluorescent response following at least partial ablation of a target; one or more instructions for determining data representative of one or more characteristics of ablation energy for further ablating a target at least partially based on the second possible dataset; one or more instructions for receiving a third input associated with a third possible dataset, the third possible dataset including data representative of a fluorescent response; one or more instructions for determining data representative of one or more characteristics of excitation energy for inducing the target fluorescent response at least partially based on the third possible dataset; one or more instructions for providing a first output to a first energy source in real time, the first output providing data associated with at least partial ablation of a target at least partially based on the first possible dataset. The one or more instructions may be, for example, computer executable and/or logic implemented instructions. In some embodiments, the signal bearing medium 1210 of the one or more computer program products 1200 include a computer-readable medium 1220, a recordable medium 1230, and/or a communications medium 1240.

[0356] FIG. 16 and FIG. 17 show a schematic of a partial view of an illustrative computer program product 1300 that includes a computer program for executing a computer process on a computing device. An illustrative embodiment of the illustrative computer program product is provided using a signal bearing medium 1310, and may include at least one of one or more instructions 1315 including: one or more instructions for receiving a first input associated with a first possible dataset, the first possible dataset including data representative of a target fluorescent response; one or more instructions for accessing the first possible dataset in response to the first input; one or more instructions for generating the first possible dataset in response to the first

input; one or more instructions for determining a graphical illustration of the first possible dataset; one or more instructions for determining data representative of a location of a target area at least partially based on the first possible dataset; one or more instructions for sending the first output associated with the first possible dataset; one or more instructions for determining data representative of one or more characteristics of excitation energy for inducing the target fluorescent response; one or more instructions for determining data representative of one or more characteristics of ablation energy for at least partially ablating a target; one or more instructions for receiving a second input associated with a second possible dataset, the second possible dataset including data representative of a second target fluorescent response following at least partial ablation of a target; one or more instructions for determining data representative of one or more characteristics of ablation energy for further ablating a target at least partially based on the second possible dataset; one or more instructions for receiving a third input associated with a third possible dataset, the third possible dataset including data representative of a fluorescent response; one or more instructions for determining data representative of one or more characteristics of excitation energy for inducing the target fluorescent response at least partially based on the third possible dataset; one or more instructions for providing a first output to a first energy source in real time, the first output providing data representative of one or more ablation characteristics for at least partially ablating the target area. The one or more instructions may be, for example, computer executable and/or logic implemented instructions. In some embodiments, the signal bearing medium 1310 of the one or more computer program products 1300 include a computer-readable medium 1320, a recordable medium 1330, and/or a communications medium 1340.

[0357] FIG. 18 and FIG. 19 show a schematic of a partial view of an illustrative computer program product 1400 that includes a computer program for executing a computer process on a computing device. An illustrative embodiment of the illustrative computer program product is provided using a signal bearing medium 1410, and may include at least one of one or more instructions 1415 including: one or more instructions for receiving a first input associated with a first possible dataset, the first possible dataset including data representative of a fluorescent response; one or more instructions for accessing the first possible dataset in response to the first input; one or more instructions for generating the first possible dataset in response to the first input; one or more instructions for determining a graphical illustration of the first possible dataset; one or more instructions for determining data representative of a location of a target area at least partially based on the first possible dataset; one or more instructions for generating the first possible output in response to the first input; one or more instructions for sending the first output associated with the first possible dataset; one or more instructions for determining data representative of one or more characteristics of excitation energy for inducing the target fluorescent response; one or more instructions for determining data representative of one or more characteristics of ablation energy for at least partially ablating a target; one or more instructions for providing a first possible output to a first motive source, the first possible output providing data representative of one or more parameters associated with move-

ment of an untethered device in a lumen at least partially based on the location of the target area. The one or more instructions may be, for example, computer executable and/or logic implemented instructions. In some embodiments, the signal bearing medium 1410 of the one or more computer program products 1400 include a computer-readable medium 1420, a recordable medium 1430, and/or a communications medium 1440.

[0358] The following provides a description of illustrative systems based on one or more of the operational flows 600, 700, and/or 800 and/or computer program products 1200, 1300, and/or 1400 and/or variations thereof as described above. These systems may also be executed in a variety of other contexts and environments, and or in modified versions of those described herein.

[0359] FIG. 20 and FIG. 21 show a schematic of an illustrative system 1500 in which embodiments may be implemented. In some embodiments, system 1500 may be the same as system 1600 and/or system 1700. In some embodiments, system 1500 may be different from system 1600 and/or system 1700. System 1500 may include a computing system environment 1510. System 1500 also illustrates an operator 1501 (e.g. a medical or veterinary professional, optionally a surgeon, a veterinarian, a nurse, a technician, etc.) using a device 1540 that is optionally shown as being in communication with a computing device 1520 by way of an optional coupling 1545. The optional coupling may represent a local, wide area, or peer-to-peer network, or may represent a bus that is internal to a computing device (e.g. in illustrative embodiments the computing device 1520 is contained in whole or in part within the device 1510, 1540, 200, 300, and/or 400 or within one or more apparatus 100 and/or 500, or one or more control circuitry 130). An optional storage medium 1525 may be any computer storage medium.

[0360] The computing device 1520 includes one or more computer executable instructions 1530 that when executed on the computing device 1520 cause the computing device 1520 receive a first input associated with a first possible dataset, the first possible dataset including data representative of a target fluorescent response; access the first possible dataset in response to the first input; generate the first possible dataset in response to the first input; determine a graphical illustration of the first possible dataset; send the first output associated with the first possible dataset; determine data representative of one or more characteristics of excitation energy for inducing the target fluorescent response; determine data representative of one or more characteristics of ablation energy for at least partially ablating a target; receive a second input associated with a second possible dataset, the second possible dataset including data representative of a second target fluorescent response following at least partial ablation of a target; determine data representative of one or more characteristics of ablation energy for further ablating a target at least partially based on the second possible dataset; receive a third input associated with a third possible dataset, the third possible dataset including data representative of a fluorescent response; determine data representative of one or more characteristics of excitation energy for inducing the target fluorescent response at least partially based on the third possible dataset; provide a first output to a first energy source in real time, the first output providing data associated with at least partial

ablation of a target at least partially based on the first possible dataset. In some illustrative embodiments, the computing device 1520 may optionally be contained in whole or in part within one or more parts of an apparatus 100 and/or 500 and/or one or more devices 200, 300, and/or 400 (e.g. control circuitry 130 of one or more tethered and/or untethered, internal and/or external, movable and/or fixed apparatus and/or device), or may optionally be contained in whole or in part within the operator device 1540.

[0361] The system 1500 includes at least one computing device 1510, 1520, 1540 and/or control circuitry 130 on which the computer-executable instructions 1530 may be executed. For example, one or more of the computing devices 1510, 1520, 1540 and/or control circuitry 130 may execute the one or more computer executable instructions 1530 and output a result and/or receive information from the operator 1501, from other external sources, and/or from one or more sensor 120, on the same or a different computing device 1510, 1520, 1540, 1610, 1620, 1640, 1710, 1720, and/or 1740 and/or output a result and/or receive information from one or more apparatus 100 and/or 500 and/or one or more device 200, 300 and/or 400 in order to perform and/or implement one or more of the techniques, processes, or methods described herein, and/or other techniques.

[0362] The computing device 1510, 1520, and/or 1540 may include one or more of a desktop computer, a workstation computer, a computing system comprised a cluster of processors, a networked computer, a tablet personal computer, a laptop computer, or a personal digital assistant, or any other suitable computing unit. In some embodiments, any one of the one or more computing devices 1510, 1520, and/or 1540 and/or control circuitry 130 may be operable to communicate with a database to access the first possible dataset and/or subsequent datasets. In some embodiments, the computing device 1510, 1520, and/or 1540 is operable to communicate with the one or more apparatus 100 and/or 500 and/or device 200, 300, and/or 400 (e.g. control circuitry 130).

[0363] FIG. 22 and FIG. 23 show a schematic of an illustrative system 1600 in which embodiments may be implemented. In some embodiments, system 1600 may be the same as system 1500 and/or system 1700. In some embodiments, system 1600 may be different from system 1500 and/or system 1700. System 1600 may include a computing system environment 1510. System 1600 also illustrates an operator 1501 (e.g. a medical or veterinary professional, optionally a surgeon, a veterinarian, a nurse, a technician, etc.) using a device 1540 that is optionally shown as being in communication with a computing device 1620 by way of an optional coupling 1545. An optional storage medium 1525 may be any computer storage medium.

[0364] The computing device 1620 includes one or more computer executable instructions 1630 that when executed on the computing device 1620 cause the computing device 1620 to receive a first input associated with a first possible dataset, the first possible dataset including data representative of a target fluorescent response; access the first possible dataset in response to the first input; generate the first possible dataset in response to the first input; determine a graphical illustration of the first possible dataset; determine data representative of a location of a target area at least partially based on the first possible dataset; send the first

output associated with the first possible dataset; determine data representative of one or more characteristics of excitation energy for inducing the target fluorescent response; determine data representative of one or more characteristics of ablation energy for at least partially ablating a target; receive a second input associated with a second possible dataset, the second possible dataset including data representative of a second target fluorescent response following at least partial ablation of a target; determine data representative of one or more characteristics of ablation energy for further ablating a target at least partially based on the second possible dataset; receive a third input associated with a third possible dataset, the third possible dataset including data representative of a fluorescent response; determine data representative of one or more characteristics of excitation energy for inducing the target fluorescent response at least partially based on the third possible dataset; provide a first output to a first energy source in real time, the first output providing data representative of one or more ablation characteristics for at least partially ablating the target area.

[0365] In some illustrative embodiments, the computing device 1620 may optionally be contained in whole or in part within one or more parts of an apparatus 100 and/or 500 and/or one or more devices 200, 300, and/or 400 (e.g. control circuitry 130 of one or more tethered and/or untethered, internal and/or external, movable and/or fixed apparatus and/or device), or may optionally be contained in whole or in part within the operator device 1540.

[0366] The system 1600 includes at least one computing device 1510, 1620, 1540 and/or control circuitry 130 on which the computer-executable instructions 1630 may be executed. For example, one or more of the computing devices 1510, 1620, 1540 and/or control circuitry 130 may execute the one or more computer executable instructions 1630 and output a result and/or receive information from the operator 1501, from other external sources, and/or from one or more sensor 120, on the same or a different computing device 1510, 1520, 1540, 1620, and/or 1720 and/or output a result and/or receive information from one or more apparatus 100 and/or 500 and/or one or more device 200, 300 and/or 400 in order to perform and/or implement one or more of the techniques, processes, or methods described herein, and/or other techniques.

[0367] The computing device 1510, 1620, 1540 may include one or more of a desktop computer, a workstation computer, a computing system comprised a cluster of processors, a networked computer, a tablet personal computer, a laptop computer, or a personal digital assistant, or any other suitable computing unit. In some embodiments, any one of the one or more computing devices 1510, 1620, and/or 1540 and/or control circuitry 130 may be operable to communicate with a database to access the first possible dataset and/or subsequent datasets. In some embodiments, the computing device 1510, 1620, and/or 1540 is operable to communicate with the one or more apparatus 100 and/or 500 and/or device 200, 300, and/or 400 (e.g. control circuitry 130).

[0368] FIG. 24 and FIG. 25 show a schematic of an illustrative system 1700 in which embodiments may be implemented. In some embodiments, system 1700 may be the same as system 1500 and/or system 1600. In some embodiments, system 1700 may be different from system

1500 and/or system 1600. System 1700 may include a computing system environment 1510. System 1700 also illustrates an operator 1501 (e.g. a medical or veterinary professional, optionally a surgeon, a veterinarian, a nurse, a technician, etc.) using a device 1540 that is optionally shown as being in communication with a computing device 1720 by way of an optional coupling 1545. An optional storage medium 1525 may be any computer storage medium.

[0369] The computing device 1720 includes one or more computer executable instructions 1730 that when executed on the computing device 1720 cause the computing device 1720 receive a first input associated with a first possible dataset, the first possible dataset including data representative of a fluorescent response; access the first possible dataset in response to the first input; generate the first possible dataset in response to the first input; determine a graphical illustration of the first possible dataset; determine data representative of a location of a target area at least partially based on the first possible dataset; generate the first possible output in response to the first input; send the first output associated with the first possible dataset; determine data representative of one or more characteristics of excitation energy for inducing the target fluorescent response; determine data representative of one or more characteristics of ablation energy for at least partially ablating a target; provide a first possible output to a first motive source, the first possible output providing data representative of one or more parameters associated with movement of an untethered device in a lumen at least partially based on the location of the target area.

[0370] In some illustrative embodiments, the computing device 1720 may optionally be contained in whole or in part within one or more parts of an apparatus 100 and/or 500 and/or one or more devices 200, 300, and/or 400 (e.g. control circuitry 130 of one or more tethered and/or untethered, internal and/or external, movable and/or fixed apparatus and/or device), or may optionally be contained in whole or in part within the operator device 1540.

[0371] The system 1700 includes at least one computing device 1510, 1720, 1540 and/or control circuitry 130 on which the computer-executable instructions 1730 may be executed. For example, one or more of the computing devices 1510, 1720, 1540 and/or control circuitry 130 may execute the one or more computer executable instructions 1730 and output a result and/or receive information from the operator 1501, from other external sources, and/or from one or more sensor 120, on the same or a different computing device 1510, 1520, 1540, 1620, and/or 1720 and/or output a result and/or receive information from one or more apparatus 100 and/or 500 and/or one or more device 200, 300 and/or 400 in order to perform and/or implement one or more of the techniques, processes, or methods described herein, and/or other techniques.

[0372] The computing device 1510, 1720, 1540 may include one or more of a desktop computer, a workstation computer, a computing system comprised a cluster of processors, a networked computer, a tablet personal computer, a laptop computer, or a personal digital assistant, or any other suitable computing unit. In some embodiments, any one of the one or more computing devices 1510, 1720, and/or 1540 and/or control circuitry 130 may be operable to communicate with a database to access the first possible

dataset and/or subsequent datasets. In some embodiments, the computing device **1510**, **1720**, and/or **1540** is operable to communicate with the one or more apparatus **100** and/or **500** and/or device **200**, **300**, and/or **400** (e.g. control circuitry **130**).

[0373] There is little distinction left between hardware and software implementations of aspects of systems; the use of hardware or software is generally (but not always, in that in certain contexts the choice between hardware and software can become significant) a design choice representing cost vs. efficiency tradeoffs. There are various vehicles by which processes and/or systems and/or other technologies described herein can be effected (e.g., hardware, software, and/or firmware), and that the preferred vehicle will vary with the context in which the processes and/or systems and/or other technologies are deployed. For example, if an implementer determines that speed and accuracy are paramount, the implementer may opt for a mainly hardware and/or firmware vehicle; if flexibility is paramount, the implementer may opt for a mainly software implementation; or, yet again alternatively, the implementer may opt for some combination of hardware, software, and/or firmware.

[0374] The foregoing detailed description has set forth various embodiments of the devices and/or processes via the use of block diagrams, flowcharts, and/or examples. Insofar as such block diagrams, flowcharts, and/or examples contain one or more functions and/or operations, it will be understood by those within the art that each function and/or operation within such block diagrams, flowcharts, or examples can be implemented, individually and/or collectively, by a wide range of hardware, software, firmware, or virtually any combination thereof. In one embodiment, several portions of the subject matter described herein may be implemented via Application Specific Integrated Circuits (ASICs), Field Programmable Gate Arrays (FPGAs), digital signal processors (DSPs), or other integrated formats. However, those skilled in the art will recognize that some aspects of the embodiments disclosed herein, in whole or in part, can be equivalently implemented in integrated circuits, as one or more computer programs running on one or more computers (e.g., as one or more programs running on one or more computer systems), as one or more programs running on one or more processors (e.g., as one or more programs running on one or more microprocessors), as firmware, or as virtually any combination thereof, and that designing the circuitry and/or writing the code for the software and/or firmware would be well within the skill of one of skill in the art in light of this disclosure. In addition, those skilled in the art will appreciate that the mechanisms of the subject matter described herein are capable of being distributed as a program product in a variety of forms, and that an illustrative embodiment of the subject matter described herein applies regardless of the particular type of signal bearing medium used to actually carry out the distribution. Examples of a signal bearing medium include, but are not limited to, the following: a recordable type medium such as a floppy disk, a hard disk drive, a Compact Disc (CD), a Digital Video Disk (DVD), a digital tape, a computer memory, etc.; and a transmission type medium such as a digital and/or an analog communication medium (e.g., a fiber optic cable, a waveguide, a wired communications link, a wireless communication link, etc.).

[0375] Those skilled in the art will recognize that it is common within the art to describe devices and/or processes in the fashion set forth herein, and thereafter use engineering practices to integrate such described devices and/or processes into data processing systems. That is, at least a portion of the devices and/or processes described herein can be integrated into a data processing system via a reasonable amount of experimentation. Those having skill in the art will recognize that a typical data processing system generally includes one or more of a system unit housing, a video display device, a memory such as volatile and non-volatile memory, processors such as microprocessors and digital signal processors, computational entities such as operating systems, drivers, graphical user interfaces, and applications programs, one or more interaction devices, such as a touch pad or screen, and/or control systems including feedback loops and control motors (e.g., feedback for sensing position and/or velocity; control motors for moving and/or adjusting components and/or quantities). A typical data processing system may be implemented utilizing any suitable commercially available components, such as those typically found in data computing/communication and/or network computing/communication systems.

[0376] The herein described subject matter sometimes illustrates different components contained within, or connected with, different other components. It is to be understood that such depicted architectures are merely exemplary, and that in fact many other architectures can be implemented which achieve the same functionality. In a conceptual sense, any arrangement of components to achieve the same functionality is effectively "associated" such that the desired functionality is achieved. Hence, any two components herein combined to achieve a particular functionality can be seen as "associated with" each other such that the desired functionality is achieved, irrespective of architectures or intermedial components. Likewise, any two components so associated can also be viewed as being "operably connected", or "operably coupled", to each other to achieve the desired functionality, and any two components capable of being so associated can also be viewed as being "operably couplable", to each other to achieve the desired functionality. Specific examples of operably couplable include but are not limited to physically mateable and/or physically interacting components and/or wirelessly interactable and/or wirelessly interacting components and/or logically interacting and/or logically interactable components.

[0377] With respect to the use of substantially any plural and/or singular terms herein, those having skill in the art can translate from the plural to the singular and/or from the singular to the plural as is appropriate to the context and/or application. The various singular/plural permutations may be expressly set forth herein for sake of clarity.

[0378] For ease of reading, all values described herein, and all numerical ranges described herein are approximate and should be read as including the word "about" or "approximately" prior to each numeral, unless context indicates otherwise. For example, the range "0.0001 to 0.01" is meant to read as "about 0.0001 to about 0.01."

[0379] It will be understood by those within the art that, in general, terms used herein, and especially in the appended claims (e.g., bodies of the appended claims) are generally intended as "open" terms (e.g., the term "including" should

be interpreted as “including but not limited to,” the term “having” should be interpreted as “having at least,” the term “includes” should be interpreted as “includes but is not limited to,” etc.). It will be further understood by those within the art that if a specific number of an introduced claim recitation is intended, such an intent will be explicitly recited in the claim, and in the absence of such recitation no such intent is present. For example, as an aid to understanding, the following appended claims may contain usage of the introductory phrases “at least one” and “one or more” to introduce claim recitations. However, the use of such phrases should not be construed to imply that the introduction of a claim recitation by the indefinite articles “a” or “an” limits any particular claim containing such introduced claim recitation to inventions containing only one such recitation, even when the same claim includes the introductory phrases “one or more” or “at least one” and indefinite articles such as “a” or “an” (e.g., “a” and/or “an” should typically be interpreted to mean “at least one” or “one or more”); the same holds true for the use of definite articles used to introduce claim recitations. In addition, even if a specific number of an introduced claim recitation is explicitly recited, those skilled in the art will recognize that such recitation should typically be interpreted to mean at least the recited number (e.g., the bare recitation of “two recitations,” without other modifiers, typically means at least two recitations, or two or more recitations). Furthermore, in those instances where a convention analogous to “at least one of A, B, and C, etc.” is used, in general such a construction is intended in the sense one having skill in the art would understand the convention (e.g., “a system having at least one of A, B, and C” would include but not be limited to systems that have A alone, B alone, C alone, A and B together, A and C together, B and C together, and/or A, B, and C together, etc.). In those instances where a convention analogous to “at least one of A, B, or C, etc.” is used, in general such a construction is intended in the sense one having skill in the art would understand the convention (e.g., “a system having at least one of A, B, or C” would include but not be limited to systems that have A alone, B alone, C alone, A and B together, A and C together, B and C together, and/or A, B, and C together, etc.). It will be further understood by those within the art that virtually any disjunctive word and/or phrase presenting two or more alternative terms, whether in the description, claims, or drawings, should be understood to contemplate the possibilities of including one of the terms, either of the terms, or both terms. For example, the phrase “A or B” will be understood to include the possibilities of “A” or “B” or “A and B.”

[0380] All references, including but not limited to patents, patent applications, and non-patent literature are hereby incorporated by reference herein in their entirety.

[0381] While various aspects and embodiments have been disclosed herein, other aspects and embodiments will be apparent to those skilled in the art. The various aspects and embodiments disclosed herein are for purposes of illustration and are not intended to be limiting, with the true scope and spirit being indicated by the following claims.

What is claimed is:

1. An apparatus including a tethered device comprising:
 - a first optical energy source configured to provide electromagnetic energy selected to stimulate an auto-fluorescent response in one or more target cells in an internal location;

- a sensor configured to detect the auto-fluorescent response;
 - control circuitry coupled to the sensor and responsive to identify a target area in real time; and
 - a second energy source responsive to the control circuitry and configured to emit energy selected to at least partially ablate the target area.
2. The device of claim 1, wherein the tethered device is a stent.
 3. The device of claim 1, wherein the tethered device is an endoscope.
 4. (canceled)
 5. The apparatus of claim 1, wherein the electromagnetic energy selected to induce the auto-fluorescent response is two photon electromagnetic energy.
 - 6-9. (canceled)
 10. The apparatus of claim 5, wherein the two photon electromagnetic energy is focused at a depth below a surface of the internal location.
 11. (canceled)
 12. The apparatus of claim 1, wherein the electromagnetic energy selected to induce the auto-fluorescent response is provided over multiple wavelengths.
 13. The apparatus of claim 1, wherein the electromagnetic energy selected to induce the auto-fluorescent response is extended-spectrum electromagnetic energy.
 - 14-18. (canceled)
 19. The apparatus of claim 1, wherein the electromagnetic energy selected to induce the auto-fluorescent response is directionally variable.
 20. The apparatus of claim 1, further comprising:
 - a third optical energy source alignable with the first optical energy source and configured to provide targeting electromagnetic energy, wherein the targeting electromagnetic energy provides a visual indication of an orientation of the electromagnetic energy selected to induce the auto-fluorescent response.
 - 21-26. (canceled)
 27. The apparatus of claim 1, wherein the electromagnetic energy selected to induce the auto-fluorescent response is programmable.
 28. The apparatus of claim 1, wherein the electromagnetic energy selected to induce the auto-fluorescent response is feedback-controlled.
 29. (canceled)
 30. The apparatus of claim 1, wherein the electromagnetic energy selected to induce the auto-fluorescent response is provided at a depth of approximately 0 to 3 mm below a surface of the internal location.
 - 31-34. (canceled)
 35. The apparatus of claim 1, wherein the sensor is configured to detect the auto-fluorescent response over extended-spectrum electromagnetic energy.
 36. The apparatus of claim 1, wherein the sensor is configured to detect a cumulative auto-fluorescent response over a time interval.
 37. The apparatus of claim 1, wherein the sensor is configured to detect a time dependent auto-fluorescent response.
 - 38-48. (canceled)
 49. The apparatus of claim 1, wherein the control circuitry is responsive to identify the target area by analysis of one or more characteristics of the auto-fluorescent response.

50. The apparatus of claim 1, wherein the control circuitry selects one or more characteristics of the energy emitted by the second energy source responsive to one or more characteristics of the auto-fluorescent response.

51-52. (canceled)

53. The apparatus of claim 1, wherein the second energy source emits X-ray energy.

54. The apparatus of claim 1, wherein the second energy source emits optical energy.

55. The apparatus of claim 1, wherein the second energy source emits charged particles.

56-58. (canceled)

59. The apparatus of claim 1, wherein one or more of the second energy source, the sensor, and the first optical energy source are in a single handheld unit.

60. The apparatus of claim 1, wherein the second energy source is manually operable.

61. The apparatus of claim 1, wherein the energy selected to at least partially ablate the target area is spatially limited.

62-66. (canceled)

67. The apparatus of claim 1, wherein the energy selected to at least partially ablate the target area is directionally variable.

68. The apparatus of claim 1, further comprising:

a fourth optical energy source alignable with the second energy source and configured to provide targeting electromagnetic energy, wherein the targeting electromagnetic energy provides a visual indication of the energy selected to at least partially ablate the target area.

69-71. (canceled)

72. A method for detecting and ablating one or more target cells comprising:

providing to an internal location a tethered device;

providing from the tethered device electromagnetic energy selected to induce an auto-fluorescent response from the one or more target cells;

detecting the auto-fluorescent response;

identifying a target area at least partially based on an analysis of the detected auto-fluorescent response; and

providing energy to at least partially ablate the identified target area in real time.

73. The method of claim 72, further comprising:

selecting the electromagnetic energy to induce the auto-fluorescent response.

74. The method of claim 73, wherein the electromagnetic energy to induce the auto-fluorescent response is selected using control circuitry.

75. The method of claim 73, wherein selection of the electromagnetic energy to induce the auto-fluorescent response is programmable.

76. The method of claim 72, wherein the target area includes microbial contamination.

77. The method of claim 72, wherein the target area includes cancer cells.

78-79. (canceled)

80. The method of claim 72, wherein the electromagnetic energy selected to induce the auto-fluorescent response is two photon electromagnetic energy.

81-84. (canceled)

85. The method of claim 80, wherein the two photon electromagnetic energy is focused at a depth below a surface of the internal location.

86-87. (canceled)

88. The method of claim 72, wherein the electromagnetic energy selected to induce the auto-fluorescent response is extended-spectrum electromagnetic energy.

89. The method of claim 72, wherein the electromagnetic energy selected to induce the auto-fluorescent response is spatially limited.

90-93. (canceled)

94. The method of claim 72, wherein the electromagnetic energy selected to induce the auto-fluorescent response is directionally variable.

95-97. (canceled)

98. The method of claim 72, further comprising:

providing to the internal location targeting electromagnetic energy alignable with the electromagnetic energy selected to induce the auto-fluorescent response, wherein the targeting electromagnetic energy provides a visual indication of an orientation of the electromagnetic energy selected to induce the auto-fluorescent response.

99-101. (canceled)

102. The method of claim 72, wherein the electromagnetic energy selected to induce the auto-fluorescent response is programmable.

103. The method of claim 72, wherein the electromagnetic energy selected to induce the auto-fluorescent response is feedback-controlled.

104. (canceled)

105. The method of claim 72, wherein the electromagnetic energy selected to induce the auto-fluorescent response is provided at a depth of approximately 0 to 3 mm below a surface of the internal location.

106-109. (canceled)

110. The method of claim 72, wherein the auto-fluorescent response is detected over an extended-spectrum of electromagnetic energy.

111. The method of claim 72, wherein the auto-fluorescent response is detected over a cumulative time interval.

112. The method of claim 72, wherein the auto-fluorescent response is detected in a time dependent manner.

113. The method of claim 72, wherein the auto-fluorescent response is detected by a sensor.

114. The method of claim 113, wherein one or more of the sensor, the electromagnetic energy selected to induce the auto-fluorescent response, and the energy to at least partially ablate the identified target area are provided by a single handheld unit.

115. (canceled)

116. The method of claim 72, wherein the target area is identified by determining one or more of a direction, a distance a time, a depth, or coordinates from which the auto-fluorescent response originated.

117-121. (canceled)

122. The method of claim 72, wherein the target area is identified by analysis of one or more characteristics of the auto-fluorescent response.

123. The method of claim 72, wherein the target area is identified using control circuitry.

124. The method of claim 72, wherein identification of the target area is at least partially based on one or more of a programmed or an automatic analysis of the detected auto-fluorescent response.

125. (canceled)

126. The method of claim 72, wherein one or more characteristics of the energy to at least partially ablate the identified target area is selected based on one or more characteristics of the auto-fluorescent response.

127-128. (canceled)

129. The method of claim 72, wherein the energy to at least partially ablate the identified target area is X-ray energy.

130. The method of claim 72, wherein the energy to at least partially ablate the identified target area is optical energy.

131. The method of claim 72, wherein the energy to at least partially ablate the identified target area is charged particles.

132. The method of claim 72, wherein microbial contamination or cancer cells in the target area are at least partially ablated.

133-136. (canceled)

137. The method of claim 72, wherein the energy to at least partially ablate the identified target area is spatially limited.

138-142. (canceled)

143. The method of claim 72, wherein the energy to at least partially ablate the identified target area is directionally variable.

144. (canceled)

145. The method of claim 72, further comprising:

providing to the internal location targeting electromagnetic energy alignable with the energy to at least partially ablate the identified target area, wherein the targeting electromagnetic energy provides a visual indication of an orientation of the energy to at least partially ablate the identified target area.

146-148. (canceled)

149. A method of treatment comprising:

providing to an internal location a tethered device;

providing from the tethered device electromagnetic energy selected to induce an auto-fluorescent response from one or more target cells;

detecting the auto-fluorescent response;

identifying a target area at least partially based on an analysis of the detected auto-fluorescent response; and

providing energy to at least partially ablate the identified target area in real time.

* * * * *