

No. 818,821.

PATENTED APR. 24, 1906.

W. C. FEELY.
COMMUNE.

APPLICATION FILED JUNE 24, 1906.

2 SHEETS—SHEET 1.

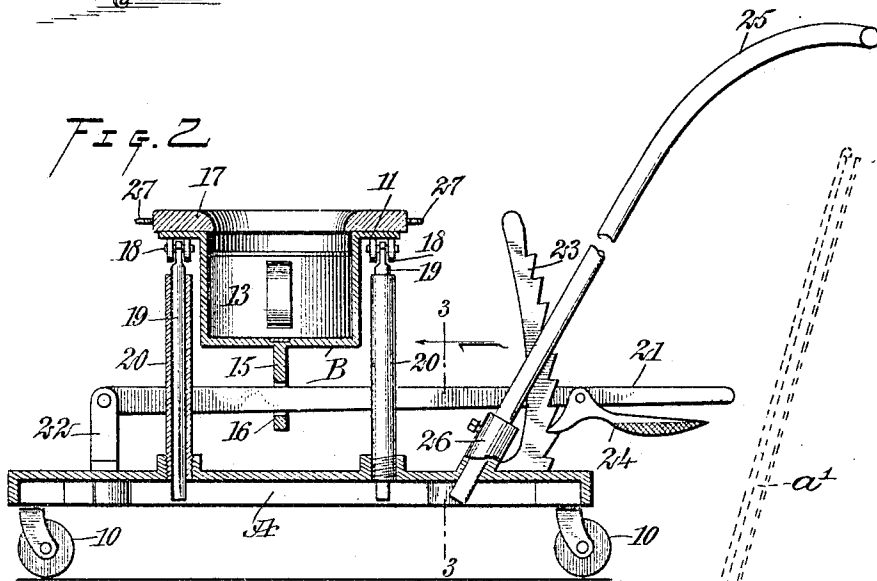
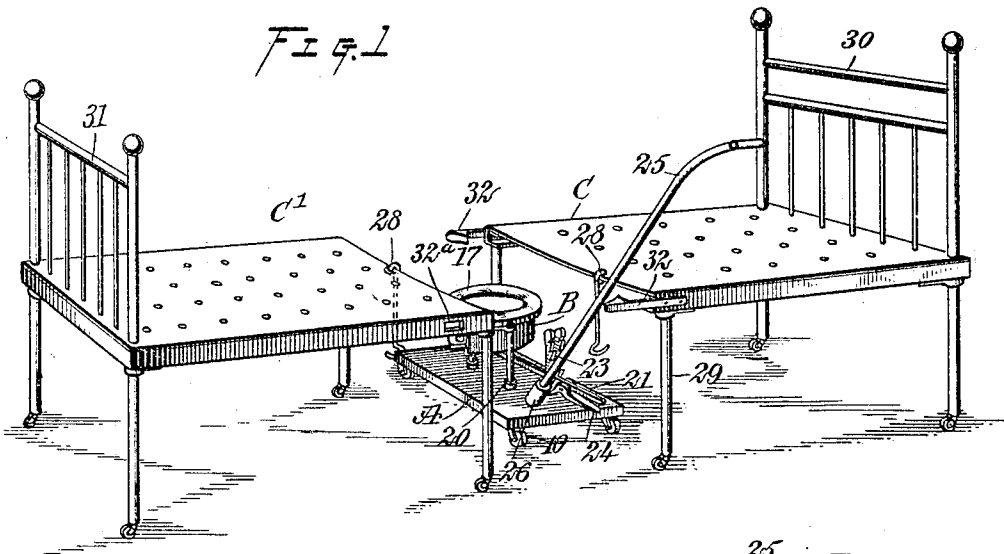
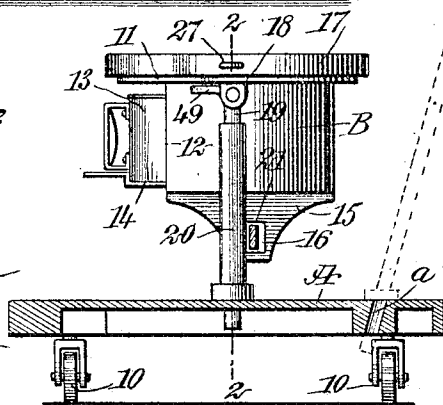

Fig. 3



WITNESSES:

John J. Neilly
John J. Neilly

INVENTOR
William C. Feely
BY *Mumford*
ATTORNEYS

No. 818,821.

PATENTED APR. 24, 1906.

W. C. FEELY.
COMMODORE.

APPLICATION FILED JUNE 24, 1905.

2 SHEETS—SHEET 2.

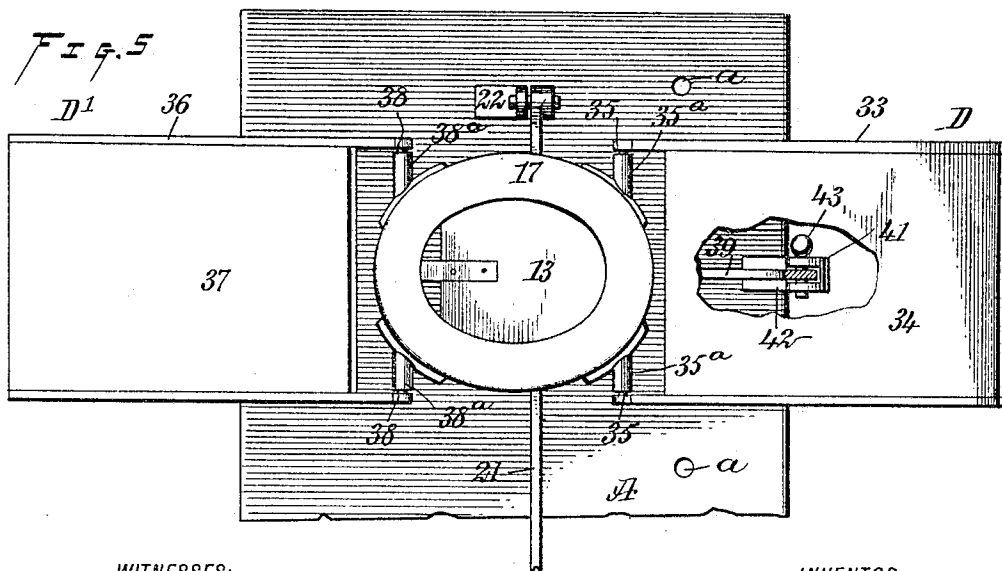
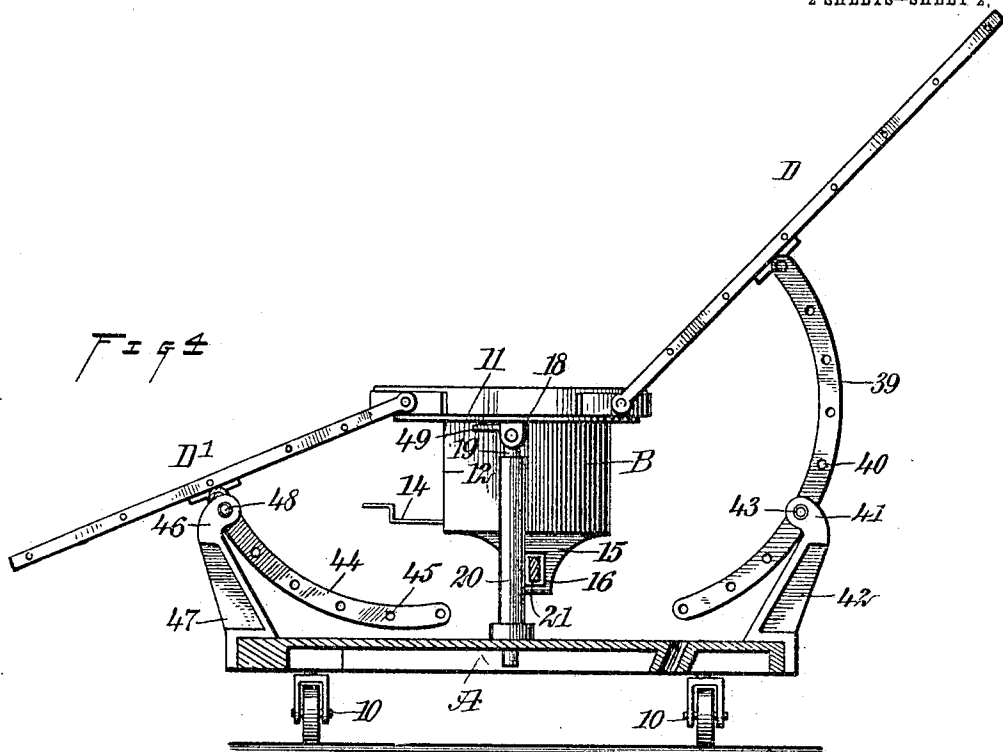

WITNESSES:

John J. Kille
Fred A. Ken

INVENTOR

William C. Feely

BY *Mumford*

ATTORNEYS

UNITED STATES PATENT OFFICE.

WILLIAM C. FEELY, OF NEW YORK. N. Y.

COMMODOE.

No. 818,821.

Specification of Letters Patent.

Patented April 24, 1906.

Application filed June 24, 1905. Serial No. 266,880.

To all whom it may concern:

Be it known that I, WILLIAM C. FEELY, a citizen of the United States, and a resident of the city of New York, borough of the Bronx, in the county and State of New York, have invented a new and Improved Commode, of which the following is a full, clear, and exact description.

The purpose of the invention is to provide a wheel-supported commode which may be used alone wherever needed, but which can be attached when required to the side of a bed, a couch, or equivalent article of furniture; and a further purpose of the invention is to provide a convenient means for bodily adjusting the commode, together with adjustable back and leg rests for the user.

Another purpose of the invention is to provide a construction of bed particularly adapted for use in connection with the commode.

The invention consists in the novel construction and combination of the several parts, as will be hereinafter fully set forth, and pointed out in the claims.

Reference is to be had to the accompanying drawings, forming a part of this specification, in which similar characters of reference indicate corresponding parts in all the figures.

Figure 1 is a perspective view of the bed and commode, illustrating the manner in which the two are used together. Fig. 2 is an enlarged vertical section through the commode, the section being taken practically on the line 2 2 of Fig. 3. Fig. 3 is a side elevation of the commode and a section through the wheeled support or truck, the section being taken practically on the line 3 3 of Fig. 2. Fig. 4 is a side elevation of the commode and a section through the truck, illustrating the application thereto of back and leg rests; and Fig. 5 is a plan view of the device as shown in Fig. 4, parts being broken away.

A represents a platform provided, preferably, with caster-wheels 10, which platform may be made of any desired material; but metal or a hard wood is preferred.

The body B of the commode is provided with an upper marginal flange 11 and an opening 12 in one side, through which a vessel 13 is introduced into the body and held in place by a suitable catch 14, as is shown in Fig. 3. A central web 15 is formed at the bottom portion of the body B, and in said web an opening 16 is made for a purpose to be hereinafter described, and a suitable seat

17 is secured to the flange 11. The flange 11 is provided upon its under face at opposite sides with downwardly-extending ears 18, and the upper ends of rods 19 are pivoted between the said ears. The rods 19 are mounted to slide in tubes 20, screwed or otherwise secured to the platform A. The tubes 20 extend through the platform, and the rods 19 are of sufficient length to extend through the tubes. A lever 21 is fulcrumed upon a standard 22, located upon the platform A, and said lever is passed through the opening 16 in the web 15 of the body of the commode, so that by raising and lowering the lever 21 the body of the commode will be correspondingly raised or lowered to adjust it for the convenience of the user.

The handle end of the lever 21 is passed between vertical rack-bars 23, and a thumb-latch 24, carried by the lever, engages with the teeth of the said rack-bars, whereby to hold the body of the commode in adjusted position. In order that the commode may be readily moved from place to place, a handle 25 is provided, which is shown as adjustably secured in a collar 26, formed upon the platform A.

The seat of the commode is shown provided with eyes 27, adapted to receive hooks 28, attached to the springs of a bed, for example, as is shown in Fig. 1, so as to hold the commode stationary at the bed side or in a given position relative to the bed. I desire it to be understood, however, that I do not confine myself to any particular means for securing the commode to a bed or similar article of manufacture.

In Fig. 1 I have illustrated a bed which is particularly adapted for use in connection with the commode. This bed is in two sections C and C', each section being complete in itself—that is to say, each section is provided with four legs 29, one at each corner, and one section—the section C, for example—has a headboard 30, and the other section C' a footboard 31. The sections C and C' of the bed may be connected in any approved manner when the bed is to be used wholly as such, and the means shown for producing such connection consists of latches 32, attached to one section—the head-section, for example—adapted for engagement with keepers 32^a, carried by the foot-section C'.

It is frequently desirable to have a back-rest for the commode, and such a rest in a simple form is illustrated by dotted lines in

Fig. 3, wherein the rest *a'* is provided with feet entering openings *a* produced in the platform A; but in Figs. 4 and 5 I have shown an adjustable head-rest D and an adjustable leg-rest D' as permanently attached to the commode. The head-rest D consists of a skeleton frame 33, having a body 34, of canvas or of any suitable material, attached thereto, and pins 35 are formed at the forward or inner ends of the side pieces of the frame 33, the said pins being adapted to enter sockets 35^a, which are secured in any approved manner to opposite sides of the seat 17 at the rear. The leg-rest D' consists of a skeleton frame 36 and a body-section 37 of canvas or like material, and the rear or inner ends of the side pieces of the said frame 36 are provided with pins 38, which enter sockets 38^a, secured to opposite sides of the said seat 17 at the front. A segmental arm 39, having a downward and forward curvature, is pivoted to the rear of the said head-rest, and this arm is provided with a series of apertures 40. The said arm is made to freely pass between the members of a bifurcated head 41, formed at the upper portion of a standard 42, the said standard being attached to the rear central portion of the platform A, and the said head-rest D is held in adjusted position by passing a pin 43 through the head 41 and the nearest aperture in the arm 39. The foot-rest D' is adjusted correspondingly to the head-rest D, as a segmental arm 44 is pivoted to the under face of the foot-rest D', which arm is given a downward and rearward curvature and is provided with a series of apertures 45. The arm 44 is loosely passed between the members of a bifurcated head 46, formed upon a standard 47, the said standard being secured to the forward central portion of the said platform A, as is shown in Fig. 4. Thus it will be observed that the commode can be used without head-rests or foot-rests or with both or either, and it is frequently desirable that the body of the commode shall be tilted rearward when in use, but cannot have a forward tilting movement—therefore the pivotal connection between the body B and the adjusting-bars 19. Lugs 49 are horizontally secured to the ears 18, the said lugs 49 extending forwardly, as is shown in Fig. 4, to an engagement with the under face of the flange 11 of the said body, as is shown in Fig. 4.

It is evident from the foregoing construction of commode that it may be rolled from place to place in a room or from one room to another and will be ready for use wherever

required, and if a person is an invalid and confined to a bed, sofa, or the like the commode can be placed in such connection with the bed or couch and so adjusted as to satisfactorily accommodate the invalid.

Having thus described my invention, I claim as new and desire to secure by Letters Patent—

1. A wheeled support, tubes secured thereto, a commode, side bars attached to the commode and mounted to slide in the said tubes, a lever fulcrumed upon the wheeled support, which lever is in operative connection with the commode to raise and lower the same, and a locking device for the lever.

2. A wheeled support, tubes secured to said support, a commode, adjusting-bars pivoted to the upper section of the commode, extending downwardly therefrom and into the said tubes, an extension from the lower portion of the commode, having an opening therein, a lever fulcrumed upon the said wheeled support, which lever passes through the opening in the said extension, and a locking mechanism for the lever.

3. A wheeled support, tubes secured to the said support, bars mounted to slide in the said tubes, a commode having pivotal connection with the upper portion of the bars, means for limiting the rocking movement of the commode upon said bars, a lever fulcrumed upon the wheeled support, being connected with the said commode to raise and lower the same, locking devices for the lever, and means for temporarily connecting the commode to a bed or a like article of manufacture.

4. A portable base, supports adjustable in the base, a commode having rocking attachment to the said support, and devices for raising and lowering the commode and supports.

5. A truck-base, supporting-bars adjustable in the base, and a commode pivotally connected with the said bars, head and foot rests pivotally connected with said commode, an adjusting device for the commode, whereby to raise and lower the same and its supports, independent adjusting devices for the head-rest and the foot-rest, and locking devices for the said adjusting devices.

In testimony whereof I have signed my name to this specification in the presence of two subscribing witnesses.

WILLIAM C. FEELY.

Witnesses:

J. FRED. ACKER,
JNO. M. RITTER.