



US008161857B2

(12) **United States Patent**  
**Roberts et al.**

(10) **Patent No.:** **US 8,161,857 B2**  
(45) **Date of Patent:** **Apr. 24, 2012**

(54) **BLIND AND SHADE CUTTING CENTER FOR CUTTING TWO DIFFERENT WINDOW COVERING PRODUCTS**

(75) Inventors: **David Roberts**, Greensboro, NC (US); **Thomas A. Caputo**, Greensboro, NC (US); **Richard D. Coulcher, Jr.**, Greensboro, NC (US); **David A. Schwartz**, High Point, NC (US)

(73) Assignee: **Newell Window Furnishings, Inc.**, High Pointe, NC (US)

(\*) Notice: Subject to any disclaimer, the term of this patent is extended or adjusted under 35 U.S.C. 154(b) by 1187 days.

1,382,433 A	6/1921	McCarty
1,647,254 A	11/1927	Simmons
1,721,276 A	7/1929	Marsilius
1,792,522 A	2/1931	Yates
1,924,162 A	8/1933	Mason
2,044,481 A	6/1936	Manley et al.
2,057,488 A	10/1936	Hochstadt
2,247,314 A	6/1941	Sellmeyer
2,418,515 A	4/1947	Lewis
D155,897 S	11/1949	Huntington
2,631,508 A	3/1953	Muehling
2,644,520 A	7/1953	Nelson
2,691,994 A	10/1954	Ferguson
2,747,625 A	5/1956	Small
2,789,639 A	4/1957	Lorentzen
2,806,493 A	9/1957	Gaskell
2,827,686 A	3/1958	Adelman

(Continued)

(21) Appl. No.: **10/462,897**

(22) Filed: **Jun. 13, 2003**

(65) **Prior Publication Data**

US 2003/0196530 A1 Oct. 23, 2003

**Related U.S. Application Data**

(62) Division of application No. 09/911,292, filed on Jul. 23, 2001, now Pat. No. 6,604,443.

(51) **Int. Cl.**  
**B26D 7/02** (2006.01)

(52) **U.S. Cl.** ..... **83/468**; 83/471.2; 83/437.1; 83/522.18

(58) **Field of Classification Search** ..... 83/454-455, 83/485, 613, 465, 471, 468, 468.1, 471.2, 83/437.1, 522.15, 522.18; 144/2.1, 5; 33/483, 33/486, 492

See application file for complete search history.

(56) **References Cited**

U.S. PATENT DOCUMENTS

239,691 A	4/1881	Appleton
421,027 A	2/1890	Hammond
702,200 A	6/1902	Greene

FOREIGN PATENT DOCUMENTS

CA 2136519 5/1996

(Continued)

*Primary Examiner* — Phong Nguyen

(74) *Attorney, Agent, or Firm* — Dennis J. Williamson; Moore & Van Allen, PLLC

(57) **ABSTRACT**

A sizing center for and a method of sizing different styles of window coverings includes at least two sizing mechanisms disposed on a sizing center in which each sizing mechanism is adapted to size a different style of window covering. Each window covering includes a color marking. At least two measuring scales are disposed on the sizing center, each measuring scale being associated with a sizing mechanism and having a different color, and each color associated with a sizing center being associated with a color marking of a window covering.

**7 Claims, 12 Drawing Sheets**

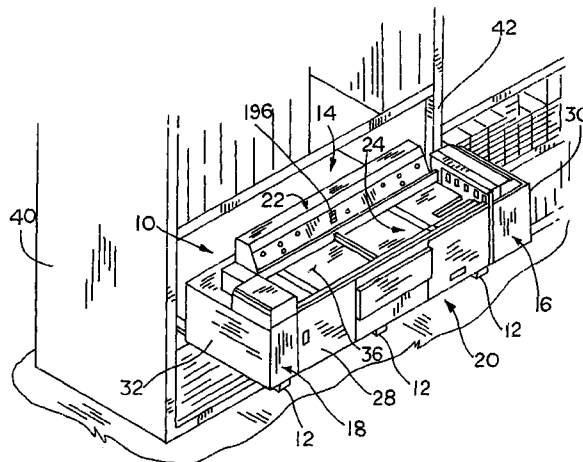

U.S. PATENT DOCUMENTS					
2,883,736 A	4/1959	Crane	5,031,488 A *	7/1991	Zumeta ..... 81/180.1
2,949,943 A	8/1960	Islandsrud	5,037,253 A	8/1991	Molaro et al.
2,987,085 A	6/1961	Porter	5,054,206 A	10/1991	Carlson
3,260,146 A	7/1966	Child	5,056,388 A	10/1991	Dekker et al.
3,263,544 A	8/1966	Margolien	5,060,709 A	10/1991	Simon
3,292,232 A	12/1966	Nilsson	5,072,494 A	12/1991	Graves et al.
3,391,591 A	7/1968	Funke	5,103,702 A	4/1992	Yannazzone
3,470,926 A	10/1969	Dohm	5,119,854 A	6/1992	Chanoine
3,501,849 A *	3/1970	Olsen ..... 434/233	5,215,512 A	6/1993	De Dompierre
3,513,740 A	5/1970	Burghart	5,251,382 A	10/1993	Hellar
3,564,893 A	2/1971	Richards et al.	5,339,716 A	8/1994	Sands et al.
3,584,380 A	6/1971	Mehler et al.	5,392,524 A	2/1995	Hill
3,618,297 A	11/1971	Hamrick	5,456,149 A	10/1995	Elsenheimer et al.
3,634,975 A	1/1972	Hensley	5,667,152 A	9/1997	Mooring
3,664,221 A	5/1972	Breetvelt	5,740,053 A	4/1998	Iwama
3,677,117 A	7/1972	Cutter	5,787,774 A	8/1998	Richards et al.
3,715,946 A	2/1973	Kaltenbach	5,799,557 A	9/1998	Wang
3,736,631 A	6/1973	Edixhoven	5,806,245 A	9/1998	Satrom
3,750,509 A	8/1973	Kruse	5,806,394 A	9/1998	Marocco
3,766,815 A	10/1973	Edixhoven	5,816,126 A	10/1998	Pluber
4,018,118 A	4/1977	Goff	5,819,619 A	10/1998	Miller et al.
4,036,092 A	7/1977	Kaltenbach	5,826,317 A	10/1998	van Oostrom et al.
4,055,206 A	10/1977	Griffin	5,882,155 A	3/1999	Testa
4,067,252 A	1/1978	Peddinghaus et al.	5,927,172 A	7/1999	Wang
4,139,043 A	2/1979	Donofrio	5,943,932 A	8/1999	Sberveglieri
4,151,768 A	5/1979	Shockovsky	5,971,839 A	10/1999	Schmelzer
4,188,693 A	2/1980	Edixhoven	6,003,217 A	12/1999	Graves et al.
4,201,256 A	5/1980	Truhan	6,003,218 A	12/1999	Schumann et al.
4,214,493 A	7/1980	Elhaus	6,079,306 A	6/2000	Liu
4,227,902 A	10/1980	Olson	6,089,134 A	7/2000	Marocco
4,230,005 A	10/1980	Varga	6,142,196 A	11/2000	Schumann et al.
4,233,782 A	11/1980	Perrault	6,178,857 B1	1/2001	Marocco
4,262,564 A	4/1981	Kaltenbach	6,202,014 B1	3/2001	Brandt et al.
4,270,253 A	6/1981	Herb et al.	6,334,379 B1	1/2002	Sudano
4,326,864 A	4/1982	Sittler	6,336,388 B1	1/2002	Marocco
4,338,710 A	7/1982	Stursa et al.	6,362,893 B1	3/2002	Francis et al.
4,367,665 A	1/1983	Terpstra et al.	6,405,406 B1	6/2002	Chen
4,407,614 A	10/1983	Muhr et al.	6,412,381 B1	7/2002	Wang et al.
4,457,197 A	7/1984	Wepner et al.	6,418,762 B1	7/2002	Munch et al.
4,468,995 A	9/1984	Mireles-Saldivar	6,427,571 B1	8/2002	Hsu
4,492,301 A	1/1985	Inaba et al.	6,500,048 B1	12/2002	Bar
4,545,100 A	10/1985	Gaillard et al.	6,523,275 B2 *	2/2003	Medford et al. .... 33/759
4,567,930 A	2/1986	Fischer	6,535,294 B1	3/2003	Arledge, Jr. et al.
4,576,072 A	3/1986	Terpstra	6,561,121 B1	5/2003	Rose
4,606,099 A	8/1986	Schluep	6,604,443 B2	8/2003	Roberts et al.
4,619,166 A	10/1986	Valavaara	6,615,698 B2	9/2003	Chuang et al.
4,625,868 A	12/1986	Bischof	6,783,563 B1	8/2004	Eckhoff
4,632,259 A *	12/1986	Cameron ..... 211/119	2002/0117039 A1	8/2002	Huang
4,639,987 A	2/1987	Georgopoulos	2002/0178884 A1	12/2002	Chuang et al.
4,721,058 A	1/1988	Hayamizu et al.	2003/0033919 A1	2/2003	Lin
4,726,273 A	2/1988	Miceli	2003/0066403 A1	4/2003	Lin
4,730,372 A	3/1988	Tsuchida	2003/0110913 A1	6/2003	Chen
4,771,667 A	9/1988	Forman et al.	2003/0140756 A1	7/2003	Lin
4,790,226 A	12/1988	Tsuchida			
4,807,363 A	2/1989	Clifton, Jr.			
4,819,530 A	4/1989	Huang			
4,823,449 A	4/1989	Chang			
4,876,795 A	10/1989	Chun-cheng			
4,901,419 A	2/1990	Voss			
4,907,325 A	3/1990	Hsu			
4,907,337 A	3/1990	Krusi			
4,924,740 A	5/1990	Wright			
4,928,369 A	5/1990	Schnebly et al.			
4,987,765 A	1/1991	Nishimura et al.			
4,993,131 A	2/1991	Graves et al.			
D316,979 S	5/1991	Reynolds			

FOREIGN PATENT DOCUMENTS

CA	2355507	2/2003
CN	250743	7/1995
CN	269841	2/1996
DE	223 048 C	6/1910
DE	857 677 C	12/1952
EP	0 265 564	6/1988
EP	0 273 535	7/1988
EP	0629 475 A1	6/1994
GB	1 213 388 A	11/1970
GB	2 258 686 A	2/1993

\* cited by examiner

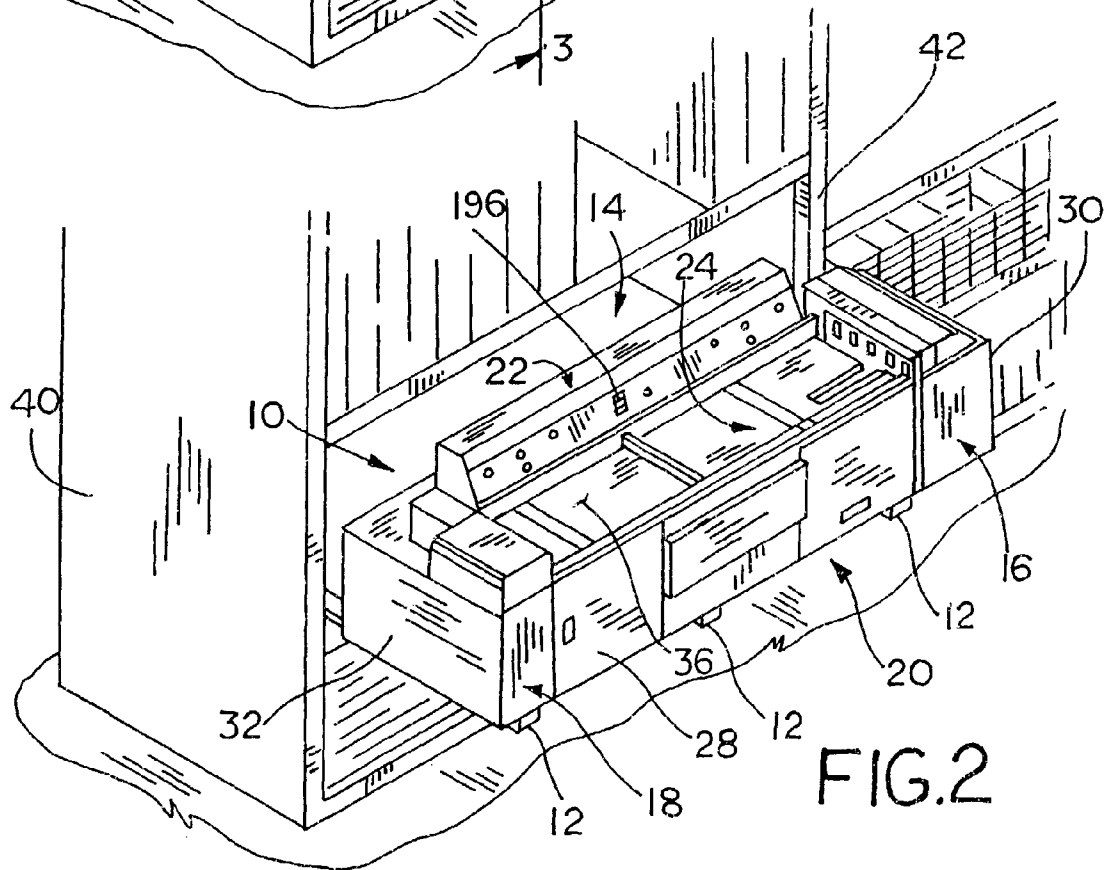
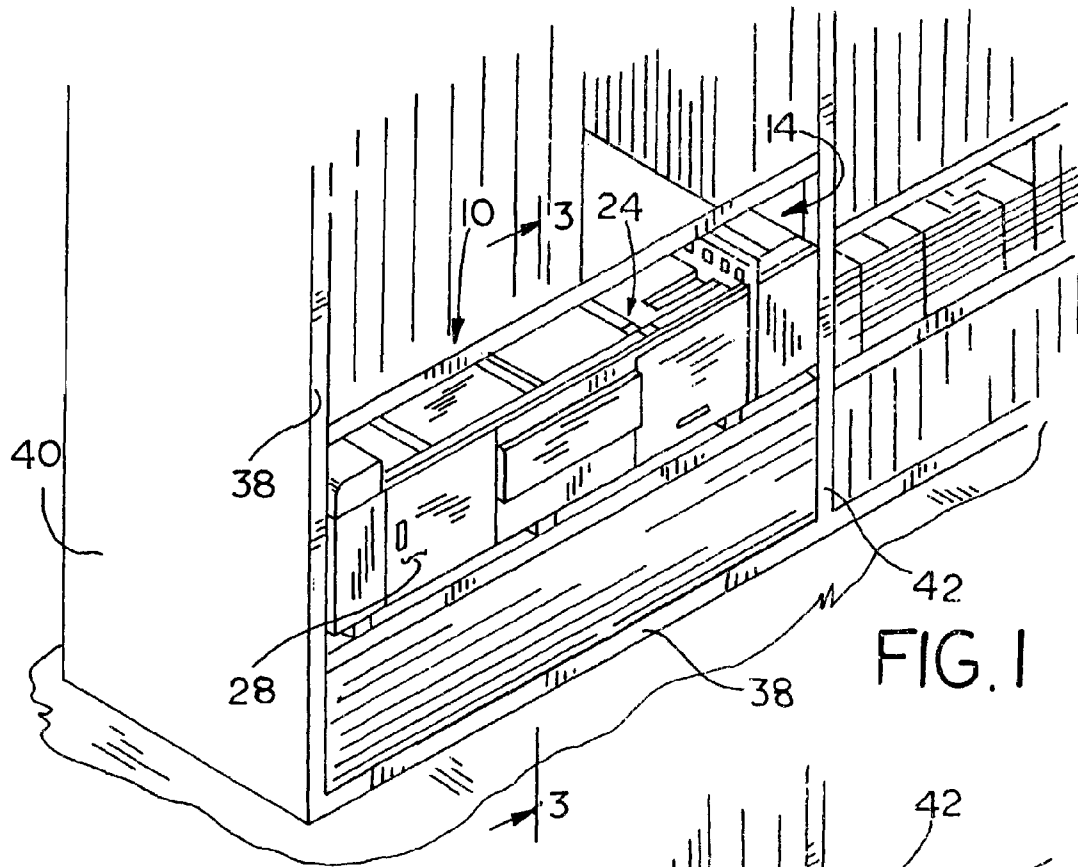

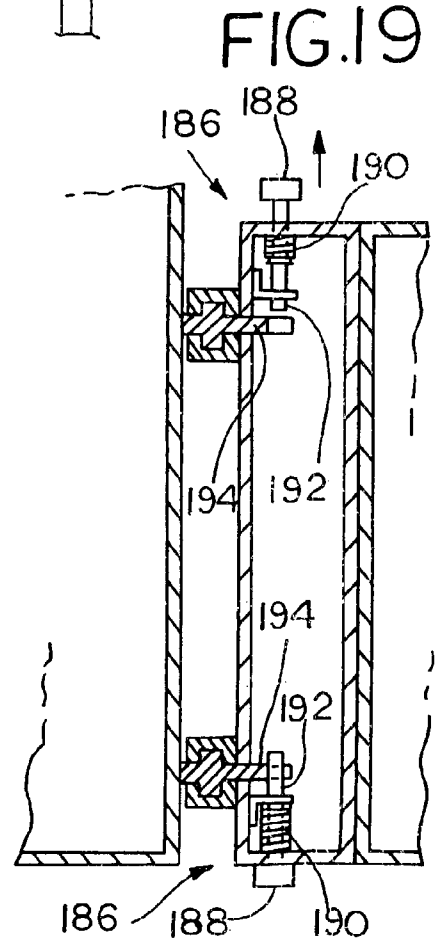
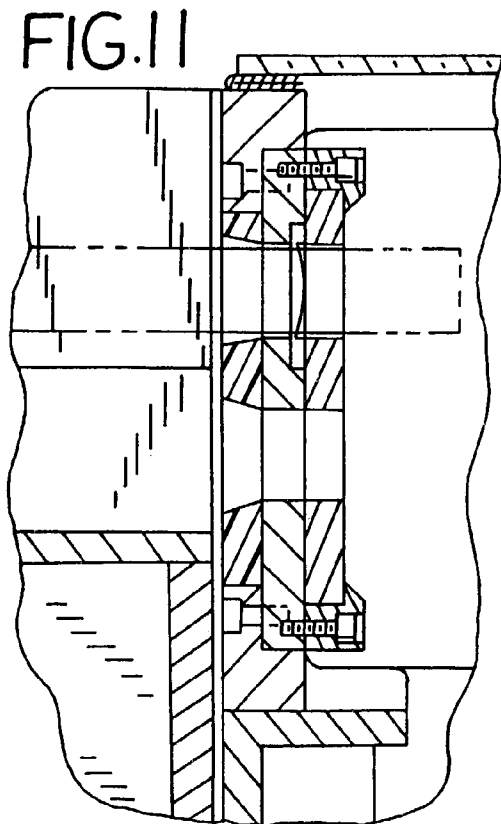
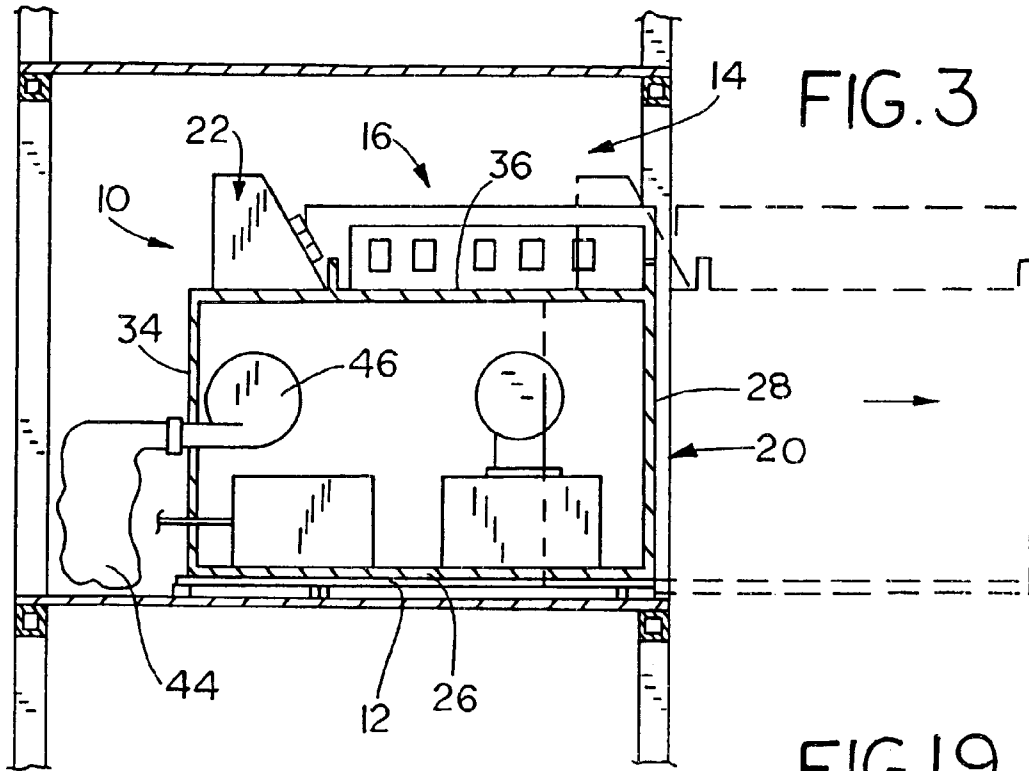

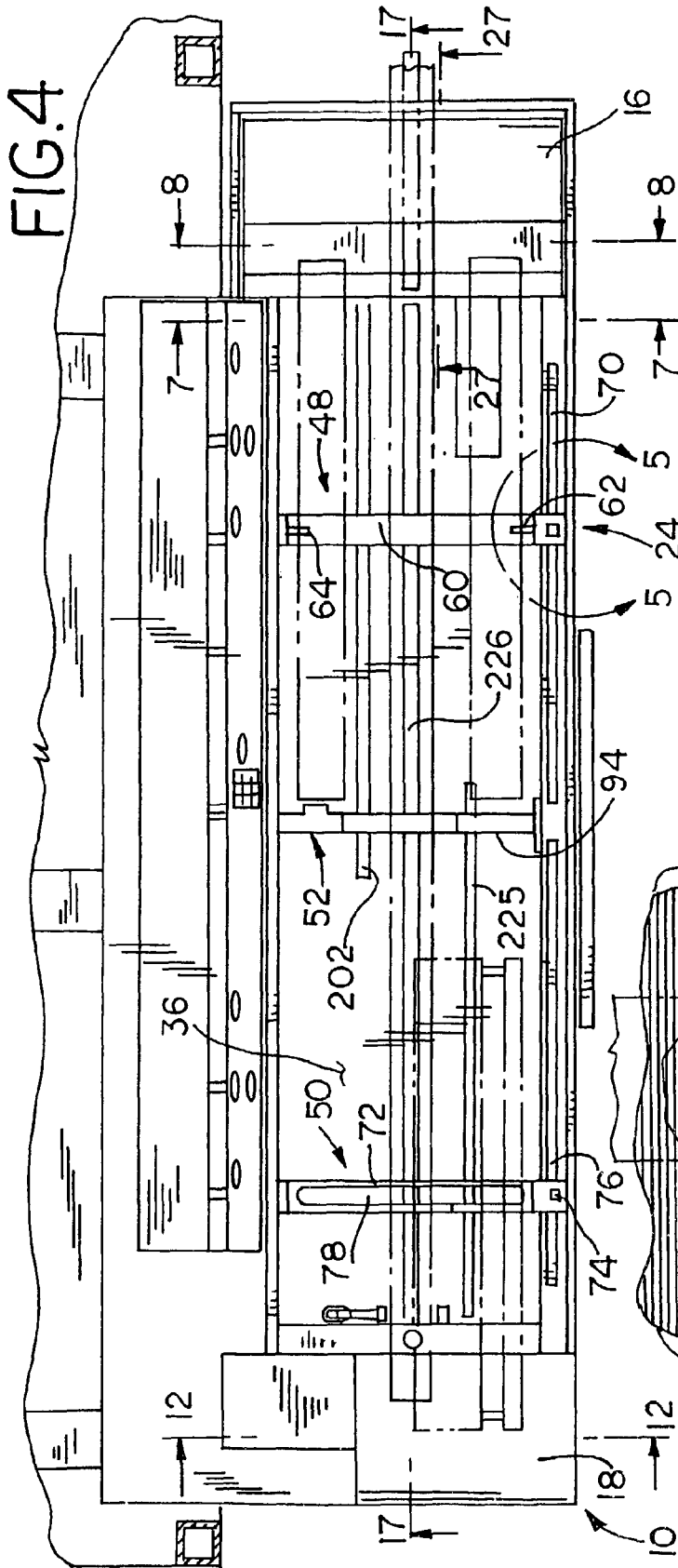

FIG. 4

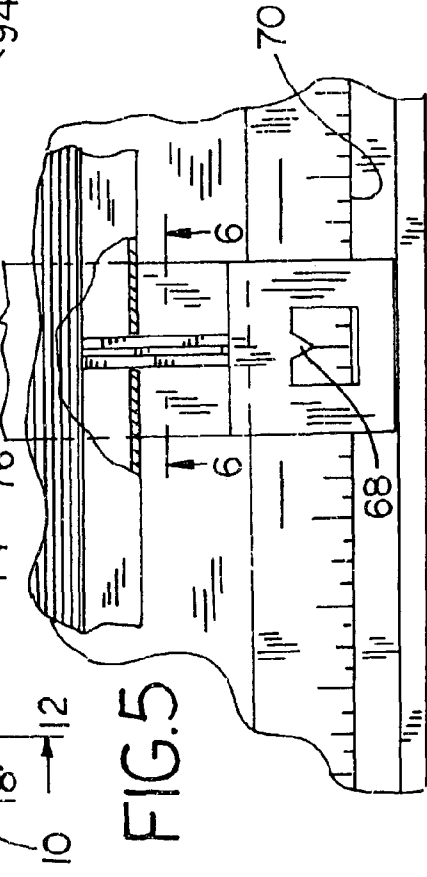

FIG. 5

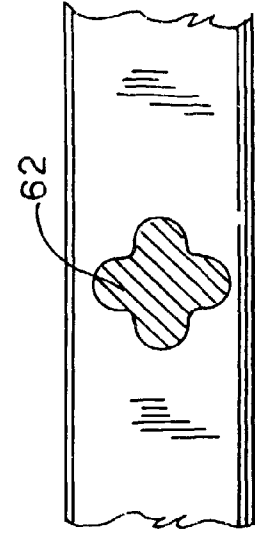
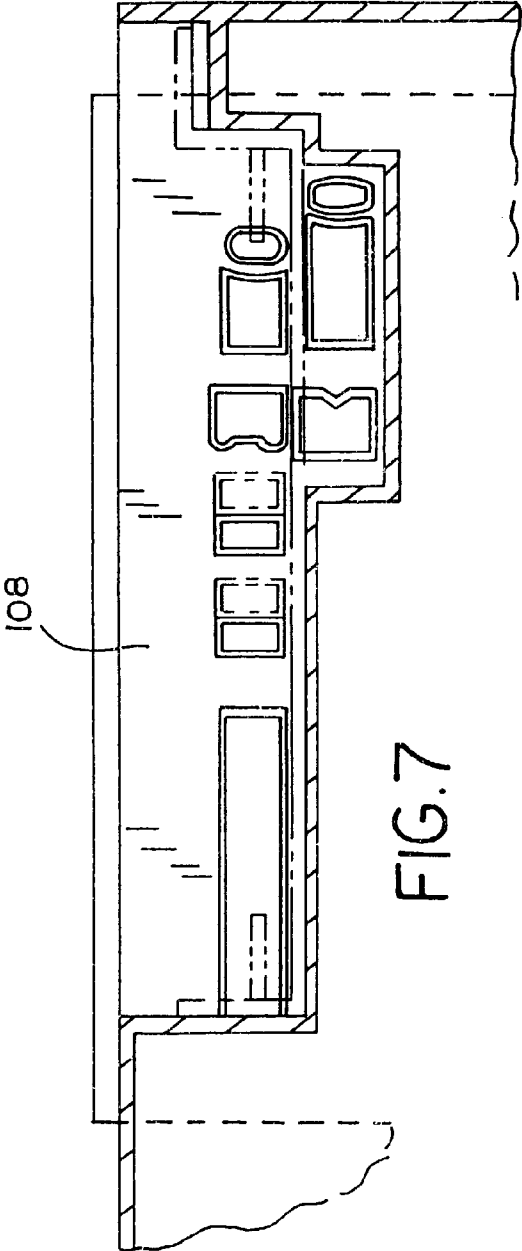
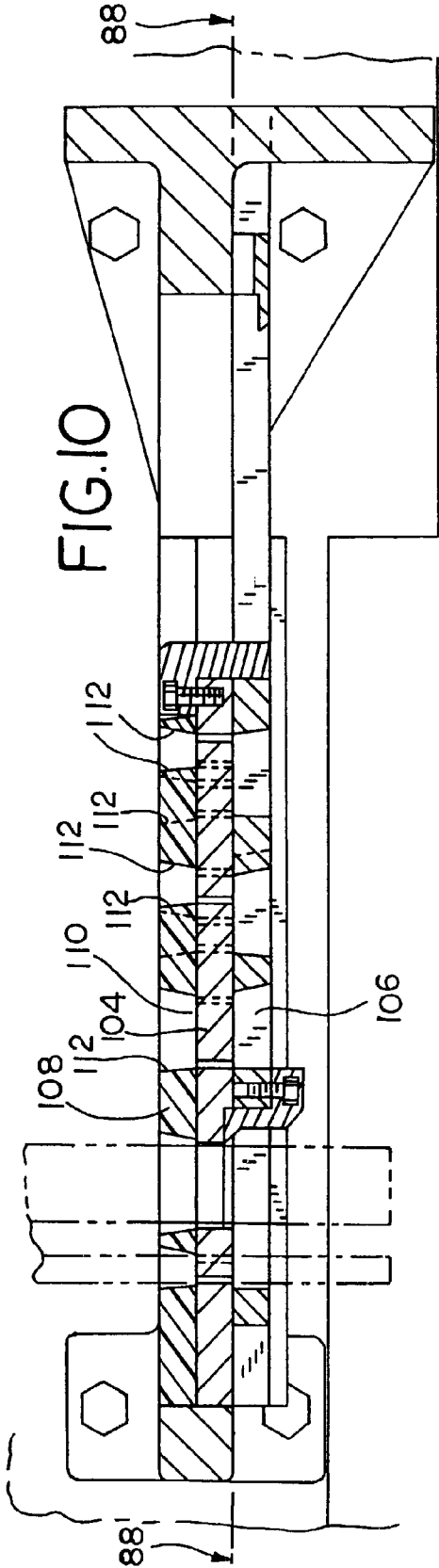
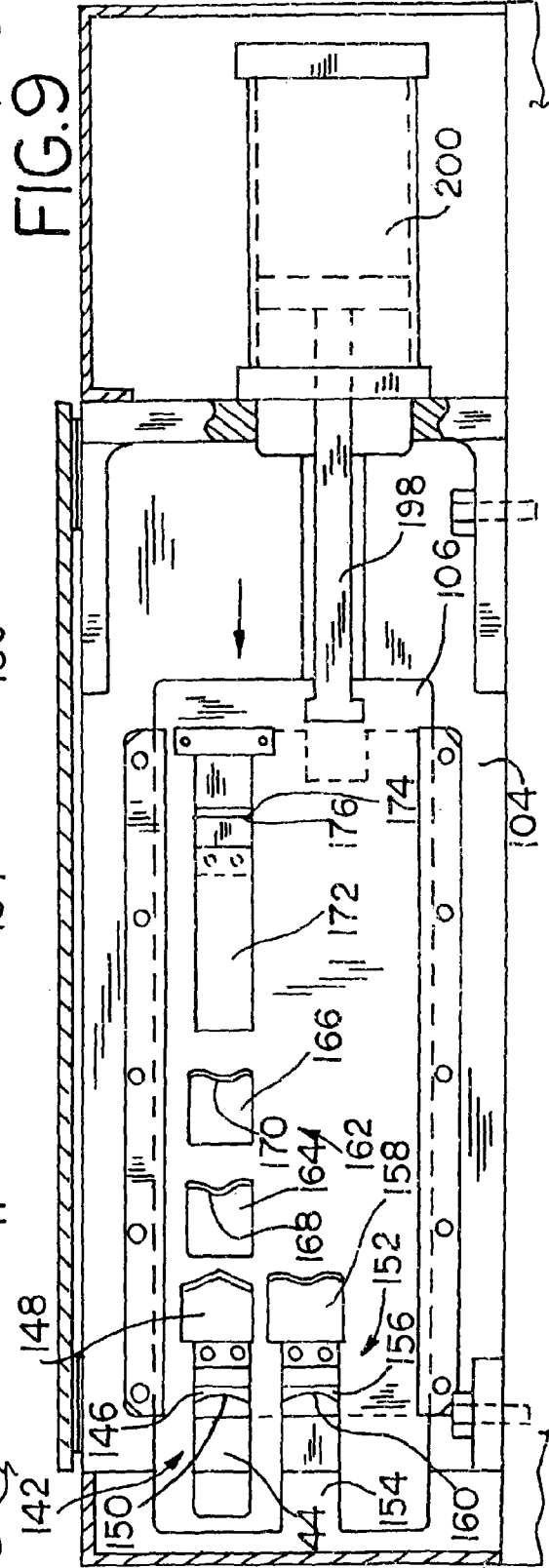
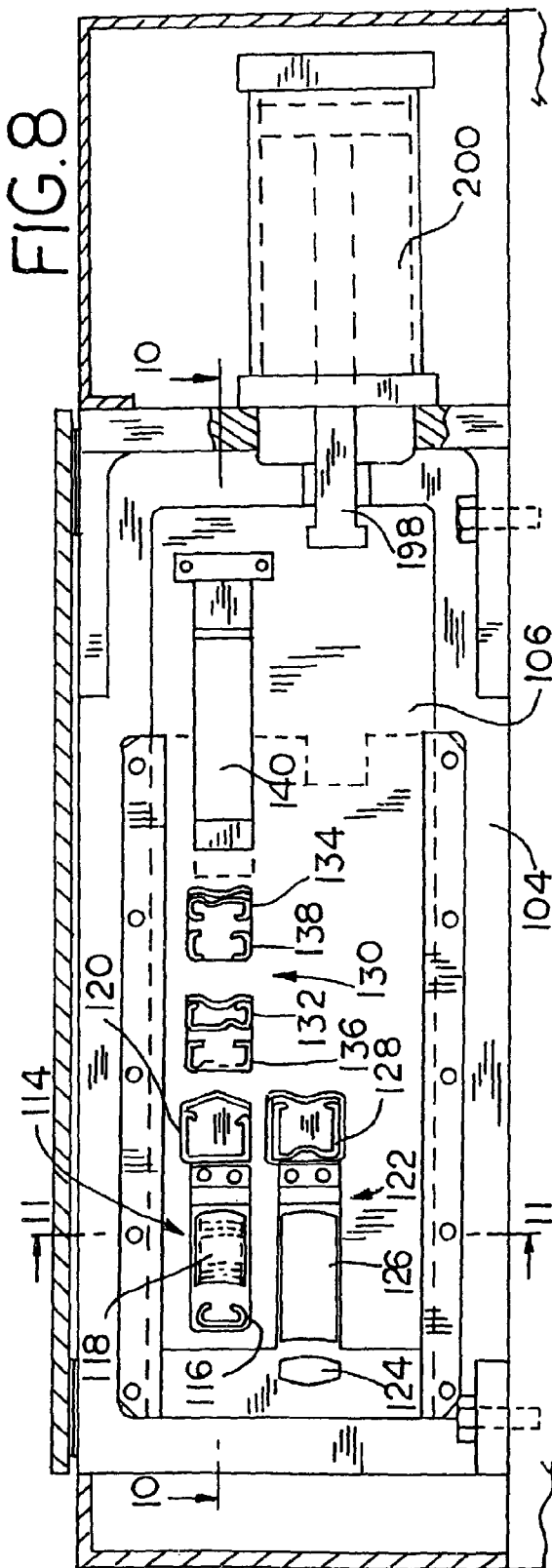
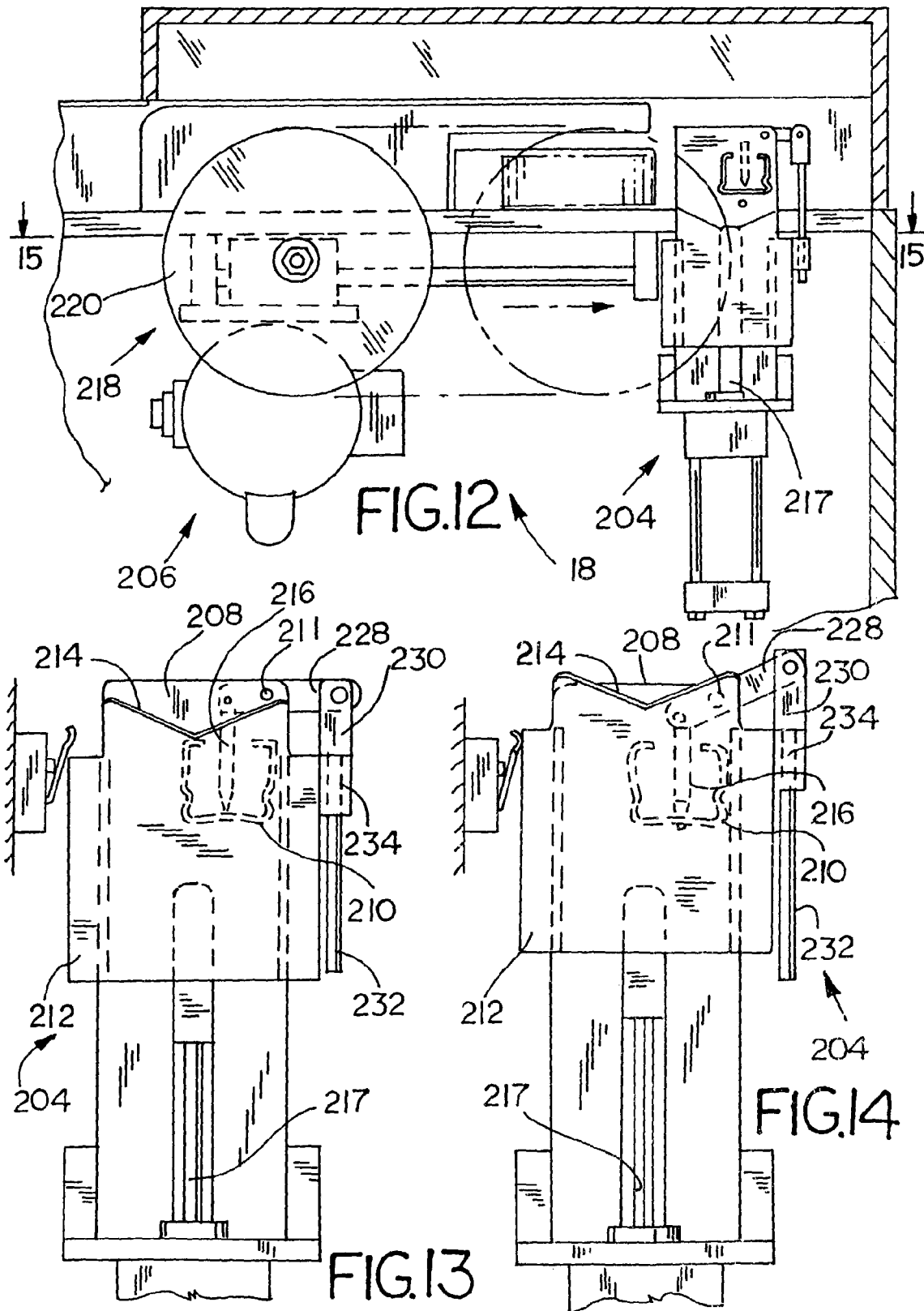

FIG. 6









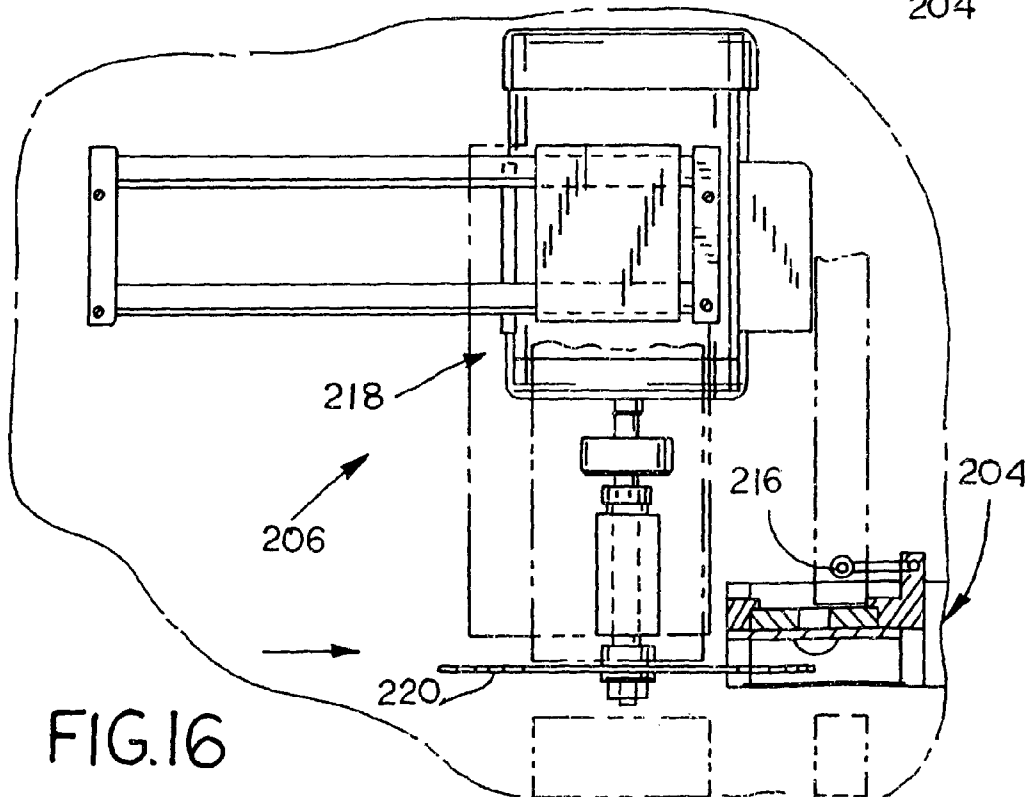
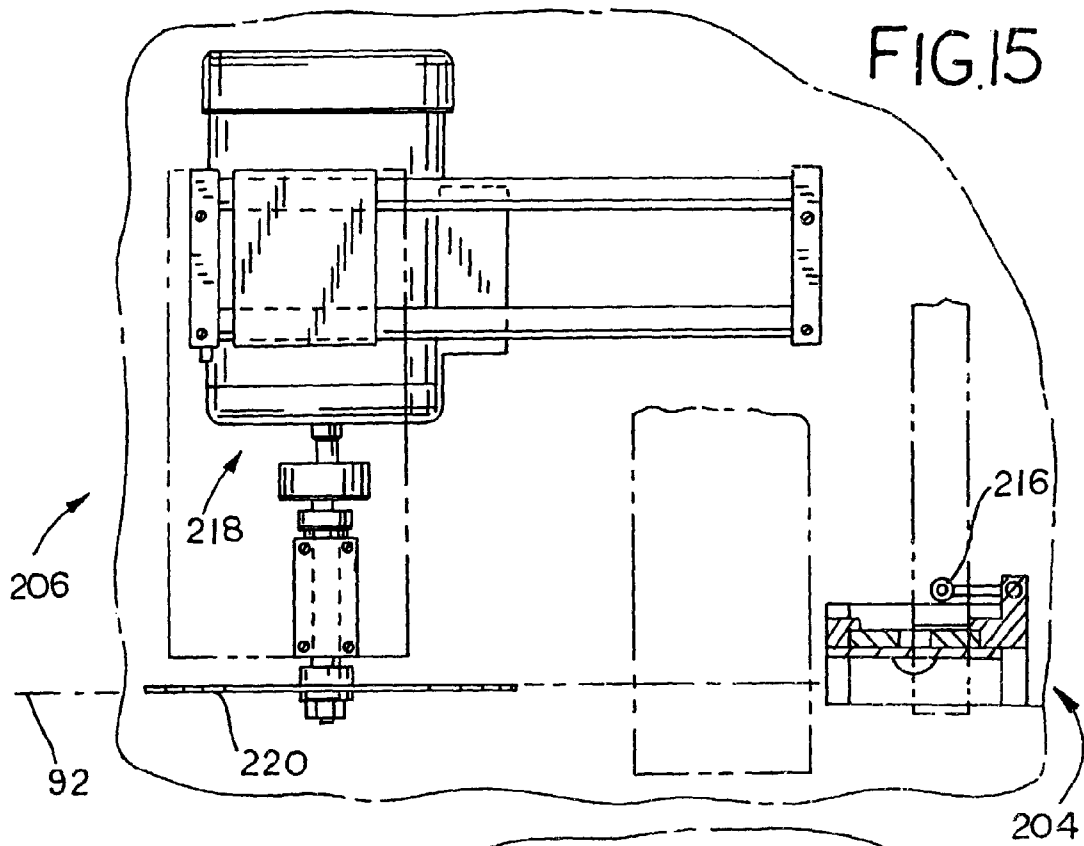

FIG 18A

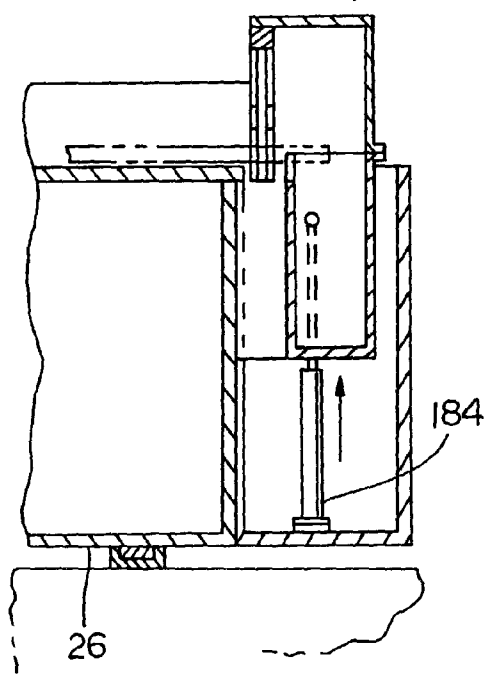

FIG.18B

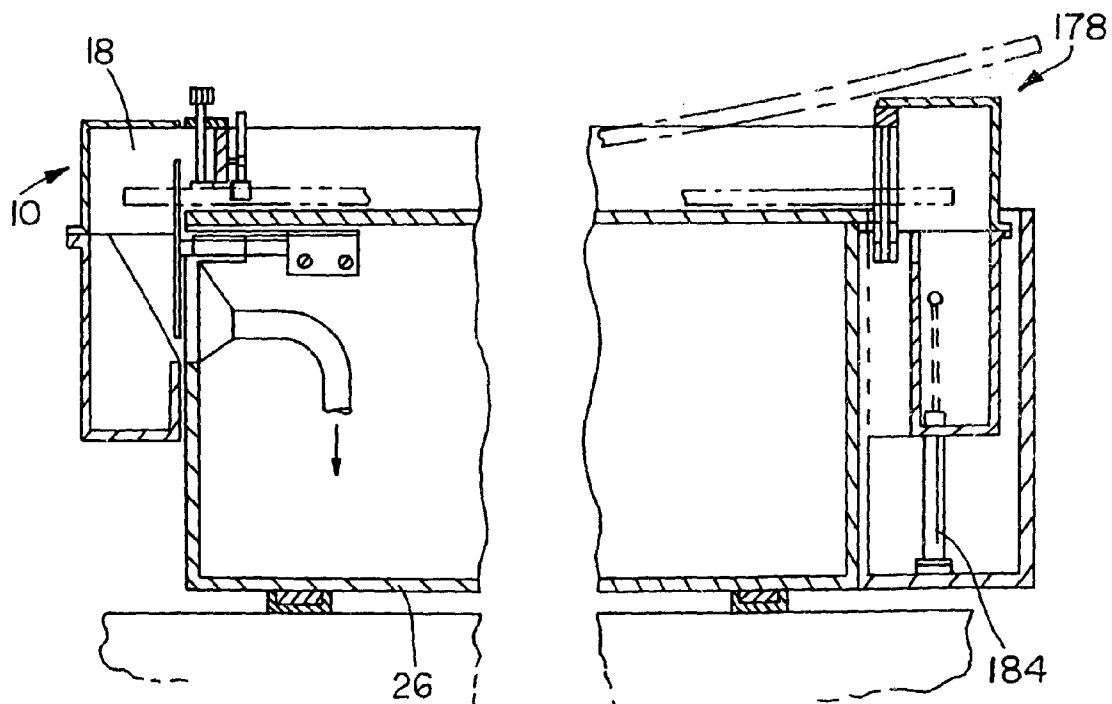
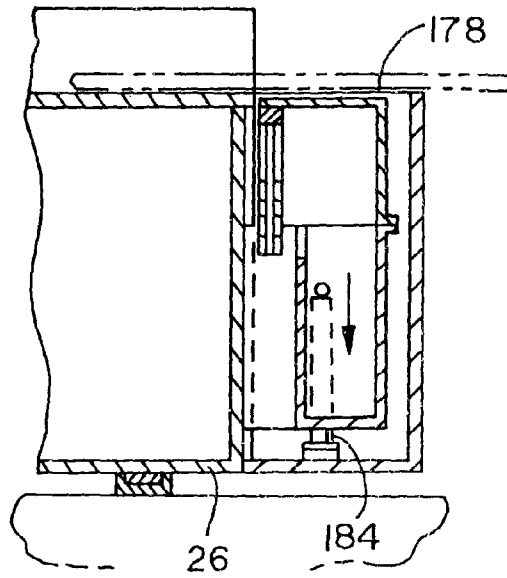

FIG.17

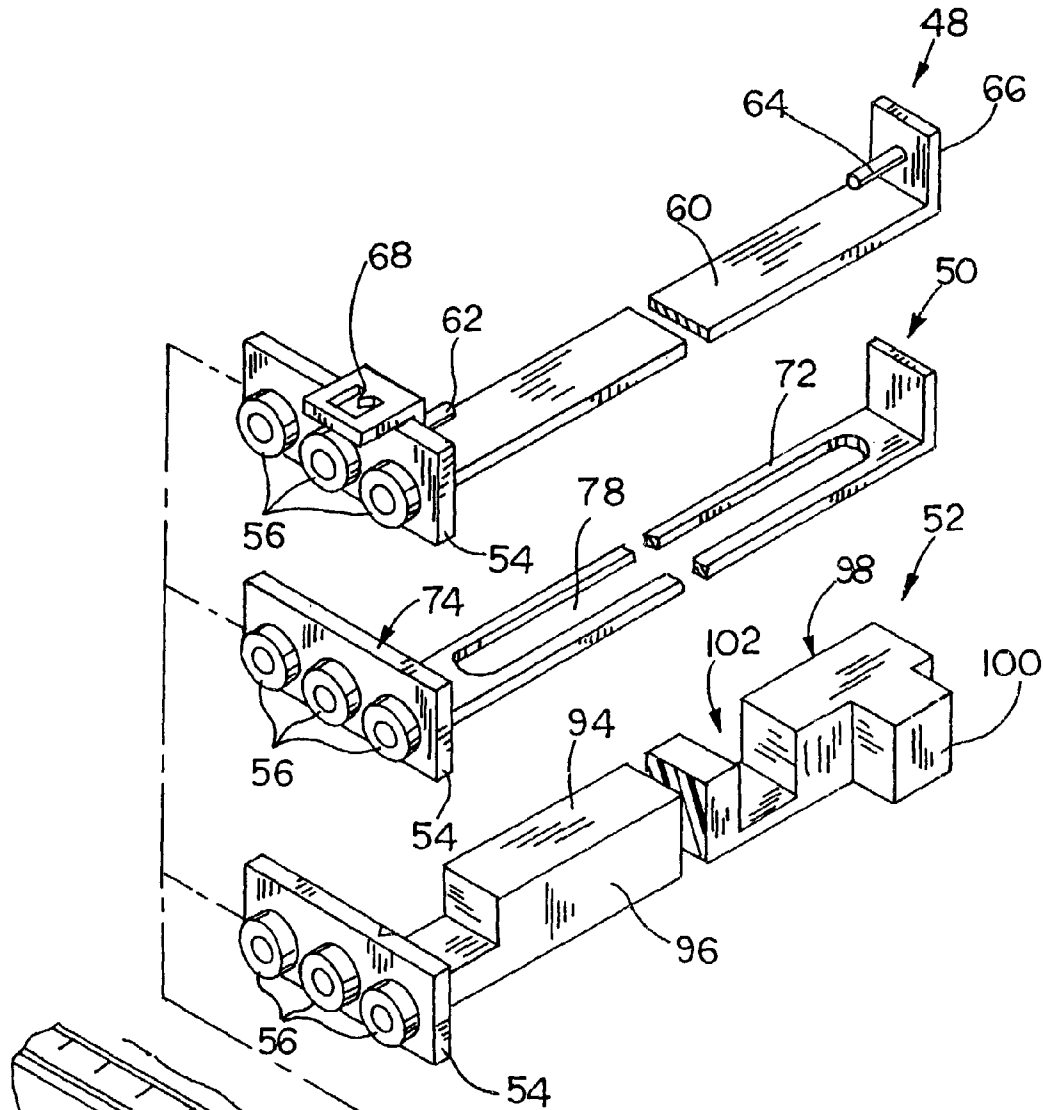

FIG.20

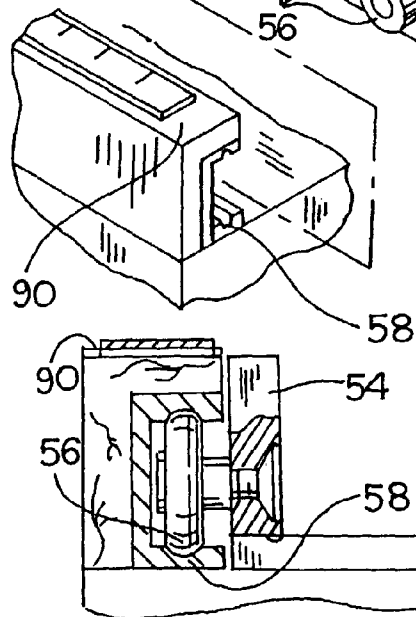

FIG.21

FIG.22

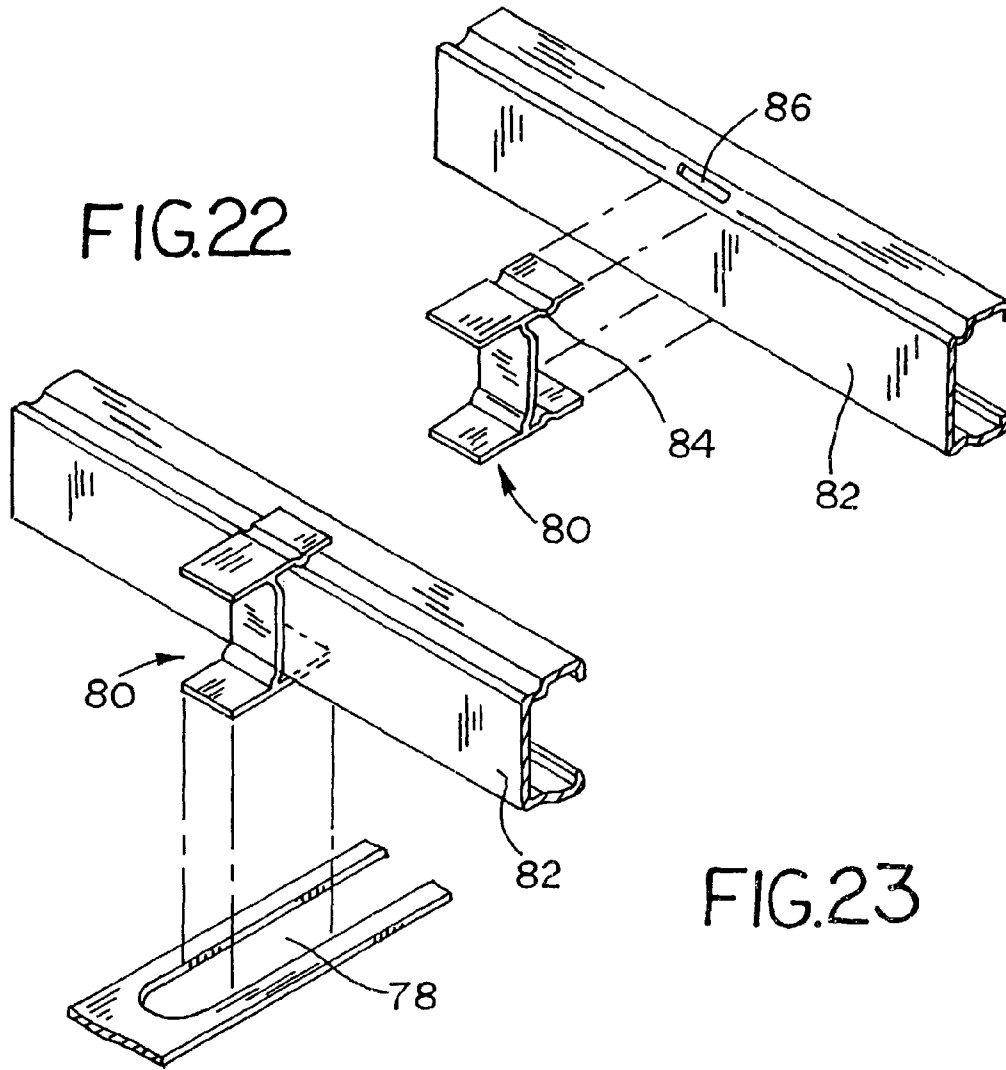
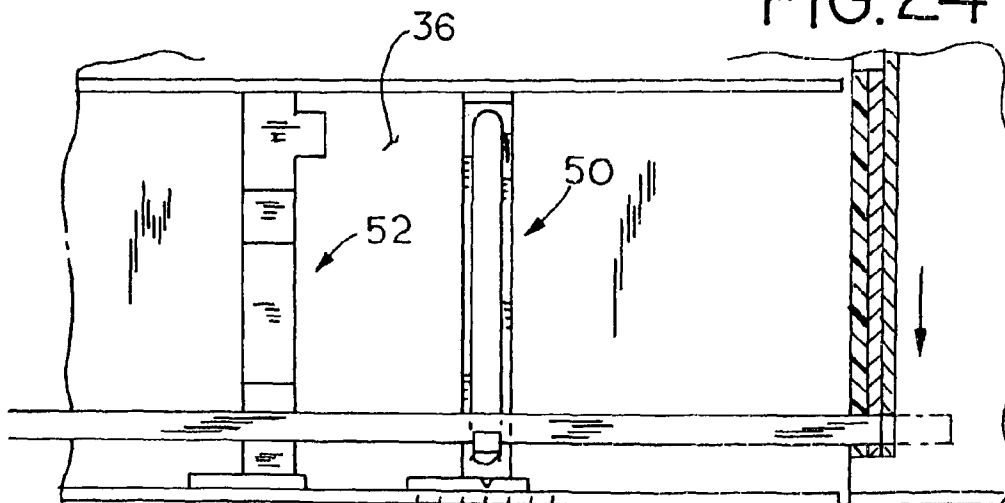

FIG.23

FIG.24



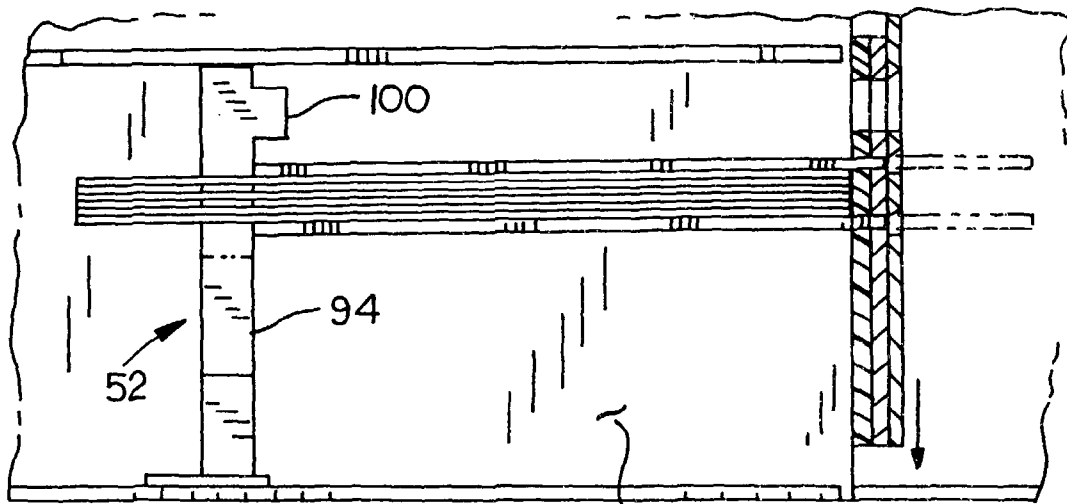

FIG. 25 36

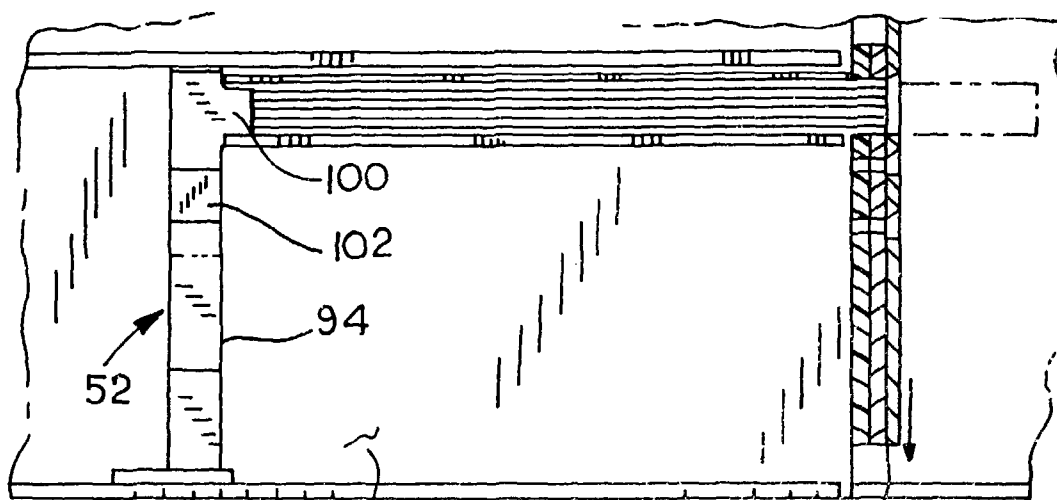

FIG. 26 70 36 88

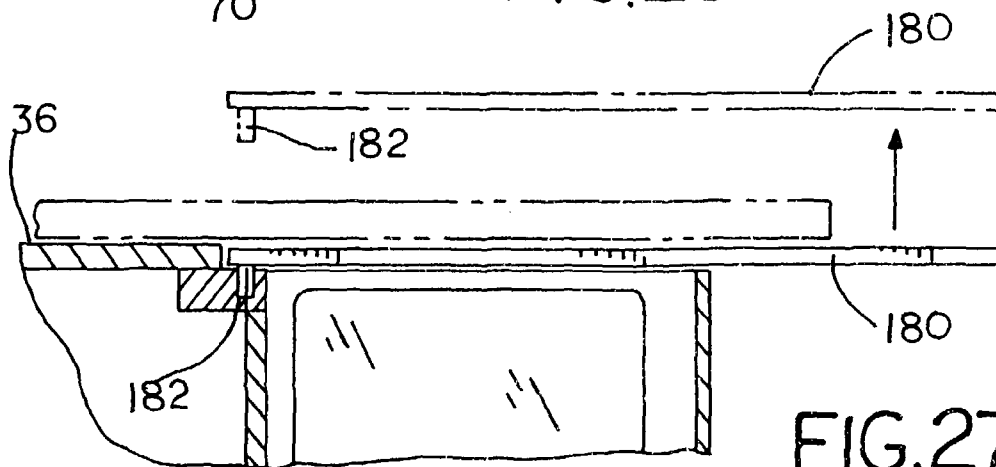
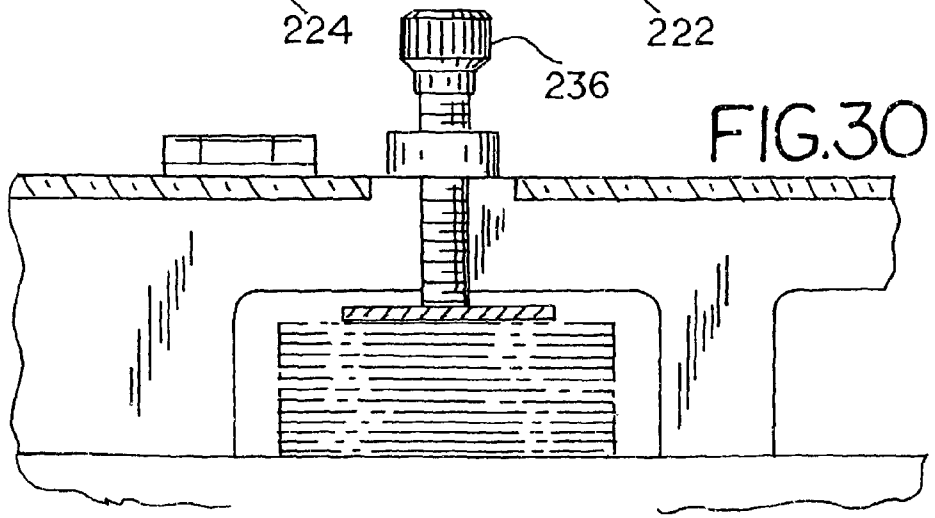
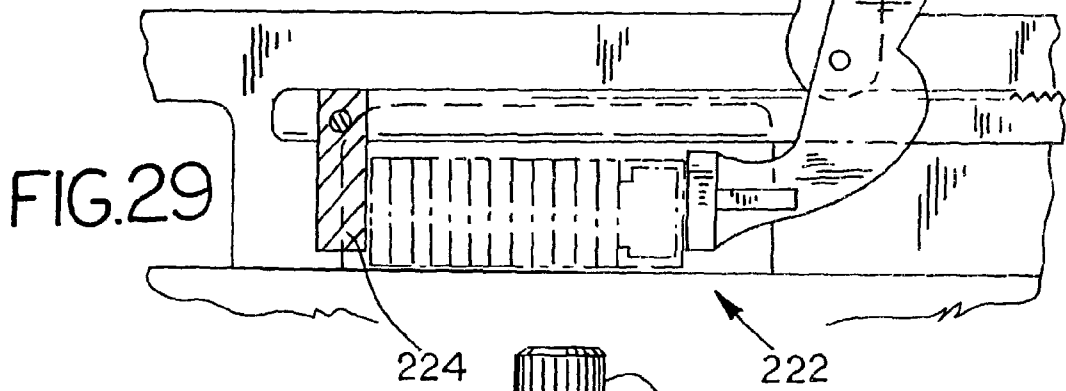
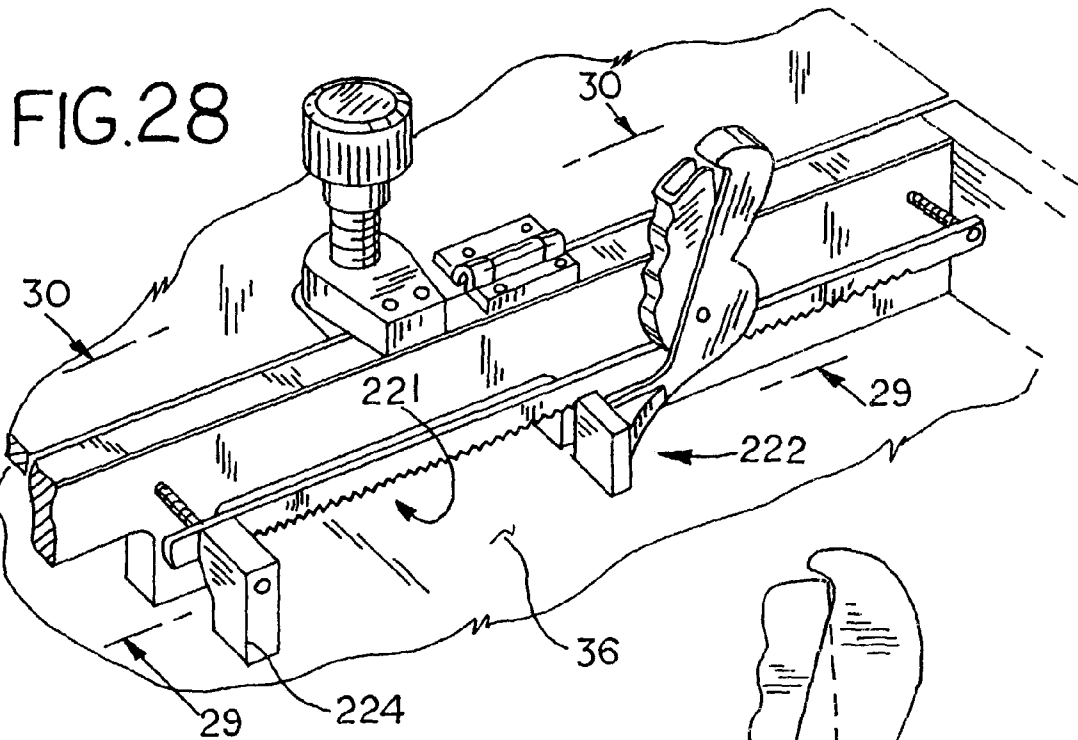

FIG. 27 180 182



1

## BLIND AND SHADE CUTTING CENTER FOR CUTTING TWO DIFFERENT WINDOW COVERING PRODUCTS

### CROSS REFERENCE TO RELATED APPLICATIONS

This application is a divisional application of and claims priority to U.S. Ser. No. 09/911,292, filed on Jul. 23, 2001, now U.S. Pat. No. 6,604,443.

### FIELD OF THE DISCLOSURE

The present invention relates generally to the field of window covering sizing machines and more particularly to a blind and shade cutting center.

### BACKGROUND OF THE DISCLOSURE

Mass retail merchandisers sell a large number of window coverings directly to consumers. Standard sized window coverings are sized to a consumer's specifications while the consumer waits. The apparatus employed to size the various window coverings must be both easy to use by an employee of a retail outlet and should not require an extensive training period.

Additionally, the floor space that the cutting apparatus requires should fit within the existing structure and layout of the retail outlet. Further, the cutting apparatus ideally should size a number of different types of window coverings, such as metal or vinyl mini-blinds, vertical blinds, pleated shades, and cellular shades.

Many attempts have been made to integrate various window covering cutting mechanisms into a single multi-station system. One example of a multi-station system is disclosed in U.S. Pat. No. 5,456,149 to Elsenheimer et al. entitled "Sizing System for Window Coverings" issued Oct. 10, 1995. The '149 patent discloses a station having a flip-top surface including a pleated shade sizing station on one side and a mini-blind sizing station on the other. This system minimizes the space required by the merchandiser to cut various window covering products. This allows the retail outlet to include other stock and products in space otherwise occupied by various window covering sizing equipment.

Recently, more retail merchandisers utilize 8-foot bay spacing to display and sell products. Accordingly, a shade and blind cutting center that can be located within the 8-foot bay environment is needed.

The sale of vertical blind products has also increased through mass merchandiser retail outlets, requiring the ability to size not only the width of the vertical blind head rail but also the length of the vertical blind slats. However, if a cutting apparatus is to be located within an 8-foot bay environment, any vertical blind slat extending greater than 8 feet would not be able to be sized with an apparatus located within the 8-foot bay. Accordingly, there is a need for a vertical blind cutting apparatus that would fit within the 8-foot bay environment as well as be able to size vertical blind slat product having a length greater than 8 feet.

### BRIEF DESCRIPTION OF THE DRAWINGS

The invention will become more fully understood from the following detailed description, taken in conjunction with the accompanying drawings.

FIG. 1 is a perspective view of the apparatus located in a bay in a stored position.

2

FIG. 2 is a perspective view of the cutting apparatus of FIG. 1 in an operating position.

FIG. 3 is a cross-sectional view of the apparatus taken generally along lines 3-3 of FIG. 1.

5 FIG. 4 is a top plan view of the apparatus of FIG. 2.

FIG. 5 is a top partial view of the area taken generally along lines 5-5 of FIG. 4.

FIG. 6 is a cross-sectional view of the locator pin taken generally along lines 6-6 of FIG. 5.

10 FIG. 7 is a cross-sectional view of the die assembly of the first cutting station taken generally along lines 7-7 of FIG. 4.

FIG. 8 is a cross-sectional view of the die and blade mechanism of the first cutting apparatus taken generally along lines 8-8 of FIG. 4.

15 FIG. 9 is the die and blade portion of the first cutting apparatus of FIG. 8 in the fully extended cutting position.

FIG. 10 is a cross-sectional view of the blade and die apparatus of FIG. 8 taken generally along lines 10-10 of FIG. 8.

20 FIG. 11 is a cross-sectional view of the cutting mechanism taken generally along lines 11-11 of FIG. 8.

FIG. 12 is a cross-sectional view of the second cutting station taken generally along lines 12-12 of FIG. 4.

25 FIG. 13 is a view of the head rail cutting mechanism with the die in the raised position.

FIG. 14 is a view of the head rail cutting mechanism die cutter in the raised position with the punch mechanism fully extended.

30 FIG. 15 is a cross-sectional view of the cutting apparatus taken generally along lines 15-15 of FIG. 12.

FIG. 16 is a cross-sectional view of the cutting mechanism taken generally along lines 16-16 of FIG. 12 in the extended cutting position.

35 FIG. 17 is a cross-sectional view of the apparatus taken generally along lines 17-17 of FIG. 4.

FIG. 18 is a partial cross-sectional view of the first cutting station in the lower position.

FIG. 19 is a cross-sectional view taken generally along lines of 19-19 of FIG. 18.

40 FIG. 20 is an exploded perspective view of three locators, rail and scale.

FIG. 21 is a cross-sectional view of the apparatus of FIG. 20.

45 FIG. 22 is an exploded perspective view of the connector clip and head rail aperture.

FIG. 23 is an exploded perspective view of the connector clip of FIG. 22 attached to the head rail aperture, and a portion of the locator.

50 FIG. 24 is a top partial view of the head rail and connector clip positioned by the locator.

FIG. 25 is a top plan view of the cellular blind head rail and bottom rail positioned in the first cutting station of FIG. 7.

FIG. 26 is a top plan view of the cellular blind shade material positioned in the first cutting station of FIG. 7.

55 FIG. 27 is a cross-sectional view of the measuring device extension.

FIG. 28 is a perspective view of the vertical slat clamp and wooden blind clamp.

FIG. 29 is a partial side view of the wooden blind clamp.

60 FIG. 30 is a partial cross-sectional view of the vertical slat clamp.

### DETAILED DESCRIPTION

65 Referring now to the drawings, an apparatus for sizing both blinds and shades for window coverings is generally illustrated in FIG. 1. The blind and shade cutting center 10 is

slidably movable on rails **12** in and out of a bay **14**. The cutting center **10** includes a first cutting station **16** for sizing mini-blinds, pleated shades, and cellular shades. The cutting center further includes a second cutting station **18** for sizing wooden blinds and vertical blinds. The first and second cutting stations **16**, **18** are supported by and located on opposing ends of a housing **20**. A controller mechanism **22** allows an operator to gain access and to control the first and second cutting stations **16**, **18**. Further, cutting center **10** includes a center locating and measuring system **24** to position the blinds and shades to be sized.

Referring to FIGS. **2** and **17** the housing **20** of the cutting center **10** includes a bottom **26**, a front wall **28**, a first and second side wall **30**, **32**, a rear wall **34**, and a top working surface **36**. For purposes of this application the cross housing direction is defined as the direction that is perpendicular to the front wall **28** and rear wall **34**. Similarly, the longitudinal direction will be defined as the direction that is perpendicular to the first and second side walls **30**, **32**. The right side of the housing **20** will be defined from the perspective of an operator as they face the bay **14**. Accordingly, the first side wall **30** is on the right side of the housing, while the second side wall **32** is on the left side of the housing. The longitudinal axis of the housing will be defined as an axis extending centrally on the top working surface **36** and perpendicular to the first and second side walls **30**, **32**. The cross center axis will be defined as an axis extending centrally on the top working surface **36** and parallel with the cross housing direction. The cross center axis is perpendicular to the longitudinal axis.

Housing **20** may be moved from a stored position (as illustrated in FIG. **1**) in which the housing **20** is located within the bay **14** to an operating position (as illustrated in FIG. **2**) in which the housing **20** is located substantially outside of the bay **14**. The stored position permits the housing to be completely out of the aisle of a retail or mass merchandising outlet. In the operating position, the housing is accessible for an operator to size a blind or shade product as will be described below. While it is possible to size a blind or shade product while the housing is in the stored position, the length of the product to be sized may be limited by the size of the bay.

The bay **14** typically includes a front surface **28** and a first and second side support **40**, **42**. The supports **40**, **42** may be in the form of a wall or may be in the form of a frame. When the housing **20** is in the stored position, the front wall **28** may be flush with the front surface **38** of the bay or may be located a distance within the bay from the aisle to ensure that no part of the cutting center **10** protrudes into the aisle. Further, if the cutting center **10** is completely located within the bay **14**, the possibility of being damaged by a forklift or customer carts is minimized.

Housing **20** may include a handle or handles (not depicted) to facilitate sliding the cutting center **10** in and out of the bay **14** on the rails **12**. All of the equipment employed in center **10** is attached to the housing **20**. The only portion of the center **10** that extends outward from the housing **20** is a vacuum bag **44** of a vacuum **46** (See FIG. **3**). The depth of the housing **20** as measured in the cross housing direction is less than the depth of the bay **14**. This permits the vacuum bag **44** to be situated behind the housing **20** when the center **10** is in the stored position. Of course the vacuum bag **44** could also be stored inside of the housing **20** and accessed through the rear wall **34** by an access means such as a door.

As will be described below, the preferred embodiment includes a center locating and measuring system as well as an end locating and measuring system. Both systems allow the operator to size a blind or shade by referring to only the customer's specification of the final size and length of the

blind. In contrast, other sizing methods required the operator to calculate the amount of material to be removed from each side of the blind and to locate the blind relative to the sizing station accordingly. This may lead to errors in the final product, resulting in both scrap material as well as a delay in the time it takes to deliver a final sized product to the consumer.

The center locating system positively locates the center of the blind to be sized, while the end locating system locates the shade relative to one end of the shade. Where the lift cords are visible to the consumer such as in a Venetian blind or a pleated shade it is important that the lift cords remain symmetrical about the center of the blind. The center locating system employs a half scale that permits an employee to size the blind by referring to only the customer's final width of the blind. In contrast, the end locating system may be used for cellular shades where the lift cords are hidden from view and it does not matter that the lift cords are not symmetric about the center of the shade. Similarly, the end locating system may be used for a vertical blind head rail and vanes where the products may be sized from a single end.

Referring to FIGS. **4** and **20**, the pin locator **48**, the center clip locator **50**, and the end locator **52** are illustrated. Each locator **48**, **50**, **52** is attached to a respective carriage **54** having a plurality of rollers **56** that are slidably received in a rail **58**. The rail **58** extends proximate the front wall **28** of the housing **20** and parallel to the longitudinal axis of the housing **20**. The rail **58** and carriage **54** device is available commercially and marketed under the trade mark Redi Rail™. The pin locator **48** and the center clip locator **50** illustrated in FIG. **20** are center locating devices that positively locate the center of the blind or shade to be sized. The end locator **52** is a locating device that is used to both square the blind or shade and to locate certain blind and shade products relative to one end of the blind.

The pin locator **48** and the center clip locator **50** both permit a blind to be sized from its center by engaging a center portion of the blind. The pin locator **48** includes an extension member **60** attached to the carriage. A pointer **68** is attached to the carriage **54** and indicates the position of the pin locator **48** relative to the first or second cutting stations **16**, **18** by use of a scale as discussed below. The extension **60** extends in the cross housing direction from the carriage **54** toward the rear of the top working surface **36**. A first pin **62** extends from the carriage **54** parallel with the top working surface **36** of the housing **20** and towards the rear wall **34**. The first pin **62** is located a predetermined distance above the top working surface **36**. A second pin **64** may extend from the rear portion **66** of the extension **60** toward the front wall **28** a predetermined distance above the top working surface **36**.

Pins **62** and **64** each have a cross section that corresponds to the cross section of an aperture in the bottom rail of the shade or blind. In the example illustrated in FIG. **6**, the pin **62** has a cross shaped cross section. However, any other shape may be employed as well, for example a round cross section may be used. Pin locator **48** includes a pointer **68** that identifies the location of the pins **62**, **64** relative to the first scale **70**.

The center clip locator **50** is illustrated in FIGS. **4** and **20**. The center clip locator **50** includes an extension **72** attached to the carriage **54** for slidable movement in the rail **58**. A pointer **74** is attached to the center clip locator **50** that identifies the position of the locator relative to a second scale **76**. The extension **72** of the center clip locator **50** includes a slot **78** having a width configured to receive and positively locate a center clip **80** attached to the center portion of the blind head rail or bottom rail (See FIG. **22**).



5

Referring to FIGS. 22 and 23, the center clip 80 is positively secured to a head rail 82 or bottom rail by positive location of a protrusion 84 of the center clip with an aperture 86 or other locating device in the center of head rail 82. Alternatively, the center clip 80 could include an aperture that is positioned relative to a detent or tab located on the head rail. Further, any other mechanical means of locating the center clip 80 onto the head rail may be employed. In the preferred embodiment the center clip 80 is made of a resilient material such that the center clip 80 may simply be located in the center of the blind head rail prior to sizing and maintained in place by the spring force of the center clip 80.

As illustrated in FIG. 4, the pin locator 48 is positioned on the right side of the cutting center 10 and the center clip locator 50 is positioned on the left side of the cutting center 10. However, this orientation is for illustration purposes only. It is possible that cutting center 10 includes two pin locators 48 on both the right and left sides of the cutting center or two center clip locators 50 on both the right and left sides of the cutting center 10. Any combination of locators 48, 50 may be employed depending on the type of locating system that is used to locate the actual products to be sized.

The pin locator 48 as illustrated in FIG. 4 is slidably positioned relative to a cutting plane 88 (See FIGS. 10 and 11) of the first cutting station 16 by the first scale 70. The first scale 70 is located on the right side of a raised portion 90 proximate the rail 58 (FIG. 20). Similarly, the center clip locator 50 is slidably positioned relative to the cutting plane 92 (See FIG. 15) of the second cutting station 18 by the second scale 76.

The first and second scales 70, 76 each include half scale indicia and extend proximate the front edge of the top working surface and parallel to the longitudinal axis. The first and second scales 70, 76 include half scale indicia where each unit of measurement is identified as twice its actual distance from the cutting planes of the first and second cutting stations respectively. For example, a distance of fifteen inches (15") from the cutting plane 88 of the first cutting station 16 is identified as thirty inches (30") on the half scale indicia.

The half scale indicia allows an employee or operator to size a window blind by only knowing the final desired width of the window blind. The width of the window blind is defined as the horizontal distance between the two sides of the window blind when the window blind is installed relative to the window or opening to be covered. The height of the window blind is the vertical distance that the window blind or shade covers. The term "length" as it is used in conjunction with the Venetian window blind head rail, slats or bottom rail will correspond to the width of the window blind.

Referring to FIGS. 4 and 20, end locator 52 includes an extension 94 attached to carriage 54 for translation along rail 58. Extension 94 extends from the carriage 54 in the cross housing direction and includes a first side 96 and a second side 98 parallel to the first side 96. The first side 96 faces the first cutting station 16 while the second side 98 faces the second cutting station 18. As will be described below the first and second sides 96, 98 of the extension 94 extend a sufficient distance from the top support surface 36 to engage the ends of the blind or shade to be sized to help align the head rail, bottom rail and window covering material for sizing. Further, the first side 96 is also used to locate the cellular shade as will be described below. End locator 52 further includes a set block 100 extending from the first side 96 a set distance toward the first cutting station 16. The end locator further includes a cut out region or a depression 102 in the top portion 94 of the extension 94 that permits a portion of the cellular window covering material of the cellular blind to extend through the extension 94 when the head rail and bottom rail

6

are being sized. The end locator is positioned between the right and left locators, which as illustrated in FIG. 4 is the pin locator and center clip locator respectively. Of course, as noted above, the right and left locators may both be pin locators or center lip locators.

Referring to FIGS. 7-10, first cutting station 16 will be described in further detail. First cutting station 16 includes a stationary die 104 and a moveable die 106 slidably coupled to the stationary die 104. A guiding die member 108 is secured to a first face 110 of stationary die 104 to provide a plurality of beveled or flared surfaces 112 for guiding the various bottom rails, slats and head rails of the blinds and shades to be sized into openings in the stationary and movable dies 104, 106.

Referring to FIG. 8, the stationary die 104 includes three regions for cutting three different types of window covering products. The first region 114 is configured for sizing a mini-blind product having metal or aluminum slats and a metal head rail and bottom rail. This mini-blind product will be referred to as the metal mini-blind product. First region 114 of the stationary die 104 includes a first channel 116 for receiving a bottom rail of a mini-blind product, and an opening 118 for receiving a plurality of metal or aluminum slats from the metal mini-blind product. Further, first region 114 of stationary die 104 also includes a second channel 120 for receiving the head rail of the metal mini-blind product.

Additionally, stationary die 104 includes a second region 122 for sizing a mini-blind having a plurality of vinyl slats. This mini-blind configuration will be referred to as a vinyl mini-blind product. This second region includes a channel 124 for receiving the bottom rail of a vinyl mini-blind product having vinyl slats and a second opening 126 for receiving the vinyl slats, and finally a third channel 128 for receiving the head rail of the vinyl mini-blind product.

The third region 130 of stationary die 104 is for sizing a pleated or cellular shade and includes a first pair of channels 132, 134 for receiving the ends of a head rail and bottom rail from a pleated or cellular shade. Similarly, third region 130 may include a second pair of channels 136, 138 for receiving the second ends of the head rail and bottom rail from a pleated or cellular shade, when the head rail and bottom rail are not symmetric. However, in the preferred embodiment, the head rail and bottom rail are symmetric and therefore only a single pair of channels is required. Accordingly, the second pair of channels 136, 138 is shown in phantom lines. The third region 130 also includes an opening 140 for receiving the pleated or cellular material to be sized.

Referring to FIG. 9, the movable die 106 similarly has three regions that correspond with the respective three regions of the stationary die 104. The first region 142 of the movable die 106 includes a first die opening 144 to receive both the portion of the bottom rail and metal slats of the metal mini-blind to be sized. A first blade 146 is attached to the movable die 106 and separates the first die opening 144 from a second die opening 148 that receives the portion of the head rail to be sized. The first blade 146 is fastened to the movable die and includes a cutting surface 150 that is proximate the stationary die 104. First blade 146 cuts both the metal slats and the bottom rail. The geometry of the first blade 146 permits the metal slats and bottom rail to be sized with the same blade without the blade chipping when it cuts the bottom rail member. First blade 146 has an arcuate surface that corresponds to an arcuate portion on the outer surface of the stationary die 104. However, other known cutting shapes may also be employed.

The second region 152 of the movable die 106 is located below the first region 142. The second region 152 includes a first opening 154 to receive both the portion of the bottom rail

and vinyl slats of a vinyl mini-blind to be sized. A second blade **156** is attached to the movable die **106** and separates the first opening **154** from a second opening **158** that receives the portion of the vinyl mini-blind head rail to be sized. The second blade **156** is fastened to the movable die **106** and includes a sharpened edge **160** that is proximate the stationary die **104**.

The third region **162** of the movable die **106** is situated in line with the first region of the movable die such that it corresponds to the third region **130** of the stationary die **104**. The third region **162** includes a first opening **164** and a second opening **166**. A shearing portion **168** is located proximate the first opening **164** and a shearing portion **170** is located proximate the second opening **166**. However, a single opening and shearing portion may also be used.

Finally, the third region **162** of the movable die includes a third opening **172** for receiving the cellular or pleated shade material to be sized. A blade **174** is attached to the movable die **106** and has a blade edge **176** to cut the cellular and pleated material as the movable die **106** is moved from a retracted position illustrated in FIG. **8** to the fully extended position illustrated in FIG. **9**.

As illustrated in FIGS. **17**, **18a**, and **18b** the stationary and movable dies **104**, **106** are attached to a frame **178** that is movable from a first position in which the first regions **114**, **142** and third regions **130**, **162** of the stationary and movable dies **104**, **106** are proximate the top working surface **36** of housing **20**, to a second position in which the second regions **122**, **152** are proximate the top working surface **36**. Further the frame **178** may be moved to a third position in which the entire first cutting station **16** is lowered to a position below the top working surface **36** to facilitate the sizing of vertical blind slats having a length greater than the width of the housing **20**.

When the entire first cutting station **16** is lowered to a position below the top working surface **36**, an extension scale **180** may be attached to the housing (See FIG. **27**). A vertical peg **182** fastens the extension to the housing **20** so that the extension scale **180** remains in a plane parallel with the top working surface **36**. This feature allows a simple disassembly upon raising the first cutting station **16** and also allows the extension scale **180** to slip out of its position on the housing if the first cutting station **16** is raised without first removing the extension scale **180**. Further, if the housing is moved back into the bay before removing the extension scale **180**, the scale will simply pivot about the peg **182** to prevent damage to the extension scale **180** or to the housing.

In the preferred embodiment, the frame is moved between the first, second and third positions with a hydraulic piston **184** that is controlled by the controller **22**. The hydraulic piston **184** is shown in FIGS. **17**, **18a** and **18b**.

In an alternative manual embodiment illustrated in FIG. **19** a pair of spring biased release mechanisms **186** is located on either side of the frame **178** to releasably secure the frame in the first, second or third positions. Each release mechanism **186** includes a spring biased button **188**, each having a spring member **190** biasing a pin **192** into engagement with one of three pairs of support members **194** attached to housing **20**. By manually pulling the engaged pair of buttons **188** in an outward direction, the pins **192** are released from the support member **194** and the frame **178** may be moved upward or downward to another one of the pair of support members. In this manner, the first cutting station **16** may be moved manually between the first, second and third positions.

The method for sizing a metal mini-blind product utilizing the cutting center **10** will now be described in detail. As discussed above, cutting center **10** can cut more than one type of mini-blind or shade product. The first cutting station **16**

includes two different regions for cutting two different types of mini-blind products. The mini-blind products could have different geometry necessitating different die openings, and/or different shearing configurations, and/or different blade combinations. In the example illustrated in the figures the first cutting station **16** permits the sizing of two different mini-blind products formed of different material and having a different geometry. In the preferred embodiment, the first regions **114**, **142** of the stationary and movable dies **104**, **106** of the first cutting station **16** are configured to size a metal mini-blind product having a metal bottom rail, a metal head rail and aluminum slats. The second regions **122**, **152** are configured to size a vinyl mini-blind product having vinyl slats.

A customer will measure the width of the window or windows to be covered and bring this dimension to a retail outlet to purchase a mini-blind product. If the mini-blind product in stock does not match the dimensions required by the customer, an employee/operator will size a stock size mini-blind product to the customer's specified dimension. This system only requires that the operator select the stock mini-blind product having a width greater than that required by the customer. The operator, as will be described herein, does not need to calculate the difference between the stock product and customer's dimensions, nor does the operator need to divide the difference between the stock mini-blind product and the customer's specifications. The operator will cut a portion of the head rail, bottom rail and window covering material from each end of the stock mini-blind product, without the need to know any value but the customer's desired end width of the mini-blind. By removing material from both ends of the mini-blind product as described below, each pair of lift cords will remain an equal distance from each respective end of the mini-blind.

Once the operator has identified and selected the stock mini-blind product closest to, yet wider than the customer's specification, the cutting center **10** is pulled from the stored position in bay **14** as illustrated in FIG. **1** to the extended position as illustrated in FIG. **2**. The operator gains access to the center controls by entering a password into the center access panel **196** of the control mechanism **22**. The control mechanism **22** may be connected to a computer that identifies the operator seeking access to the cutting center **10**. The computer may also store the information entered by the operator including the time of entry. The system may further be programmed to allow the operator to enter information relative to the stock blind being sized as a way of monitoring inventory. Additionally, the time required to size the mini-blind may be recorded. The access panel **196** has the added benefit of prohibiting unauthorized personnel from accessing the cutting center **10**.

After the cutting center **10** has been activated by means of the access panel **196**, the operator loads the stock mini-blind product onto the top working surface **36**. As discussed above, both the pin locator and central clip locator for centrally locating the stock mini-blind to be sized may be utilized. For illustration purposes only, the pin locator will be described for locating the mini-blind product relative to the first cutting station **16** and the center clip locator will be described for locating the wooden mini-blind product relative to the second cutting station **18**. However, the center clip locator could be used to locate the mini-blind product relative to the first cutting station as well.

When using the pin locator, the bottom rail of each stock mini-blind product includes a centrally located aperture or opening through the bottom most portion of the bottom rail. The aperture could also be a slot extending perpendicular to

the longitudinal axis of the bottom rail, or an indentation or depression or connector or any other means for centrally locating the mini-blind product. The aperture is centrally located in the bottom rail, however, the aperture or locating means could also be located in the head rail. The operator locates the aperture onto pin **62** of the pin locator **48**. The portions of the first end of the head rail, bottom rail and slats that are to be cut off are slid through the first regions **114**, **142** of the stationary and movable dies **104**, **106**. The bottom rail is located in channel **116** of the stationary die **104** and opening **144** of the movable die **106**. Similarly, the slats are located in opening **118** of the stationary die **104** and opening **144** of the movable die **106**. Finally, the head rail is located in channel **120** of the stationary die **104** and opening **164** of the movable die **106**.

The stock mini-blind product is positioned relative to the cutting plane **88** of the first cutting center **16** by lining up pointer **68** of the pin locator **48** with the customer's specification on the half scale indicia on first scale **70**. The half scale indicia is dimensioned relative to the cutting plane **88** of the first cutting station **16** which is generally defined by the outer surface of the stationary die **104** that determines the location of the sized end of the head rail, bottom rail and slats after the movable-die **106** is activated and shears and/or cuts the head rail, bottom rail and slats. The half scale units are one half of the actual distance from the cutting plane. For example thirty (30) inches on the half scale is only one half of thirty (30) or actually only fifteen (15) inches from the cutting plane. Once the movable die **106** is activated the newly cut ends of head rail, bottom rail and slats will be 15 inches from the center aperture.

To activate the movable die **106** in the first cutting station **16**, the operator turns on the first cutting station **16** with an on/off switch located on the controller **22**. By simultaneously depressing the to activation buttons, the movable die **106** is moved from the rest position to the extended position by a plunger **198** that is driven by a pneumatic or hydraulic cylinder **200**. The first blade **146** shears the slats and subsequently the bottom rail, while the shear portion of opening **148** shears the head rail. If the operator releases the activation buttons during the cutting process, the movable die **106** will stop. This feature ensures that the operator's hands are safely away from the movable die **106** during the activation sequence. Once the movable die **106** is fully extended and the first end of the head rail, bottom rail and slats are sized, the movable die **106** retracts to the rest position.

After the first side of the mini-blind product is sized, the operator removes the mini-blind product from pin **62** and rotates it such that the sized end of the mini-blind product is away from the first cutting station **16**. The center aperture on the bottom rail of the mini-blind product is once again located on pin **62**. Once the mini-blind has been located, the movable die **106** is activated and the second side of the head rail, bottom rail and slats are sized. In this example the desired width of the mini-blind product was thirty (30) inches. Since each side of the blind was sized relative to the central locating hole in the bottom rail, the cut ends of the mini-blind product are fifteen (15) inches from the center for a total mini-blind width of thirty (30) inches. In this manner the lift cords are equal distance from the center of the mini-blind product and equal distance to their respective ends of the sized mini-blind product.

The sizing of the metal mini-blind occurs while the first cutting station **16** is in the first position relative to housing **20** as described above. A vinyl mini-blind is sized in a second position of the cutting station. To move the first cutting station **16** to the second position utilizing the hydraulic piston, the

operator utilizes the controller **22** to move the first cutting station **16** to the second position. In the alternative embodiment, the manual release mechanism **185** may be used to move the frame. The buttons **188** of the release mechanism are pulled outward releasing the pins **192** from the support members **194** thereby permitting the operator to move the first cutting station **16** upward until the buttons are aligned with and engaged with a second pair of support members **194**. The steps for sizing the vinyl mini-blind in the first cutting station are the same as the steps for sizing the metal mini-blind as described above. However, the vinyl mini-blind is sized in the second regions **122**, **152** of the stationary and movable dies **104**, **106**.

The process of sizing a pleated or cellular shade will now be described. The pleated material is sized independently of the bottom rail and head rail. The shearing portions **168**, **170** of the third portion **162** of movable die **106** that are used to size the bottom rail and head rail of a pleated shade are not sharp enough to cleanly cut the material. The pleated material is sized in a separate step from the sizing of the head rail and bottom rail utilizing a sharp blade **174**. In a pleated blind the lift cords are visible and therefore it is desirable to have the pair of lift cords be symmetrical with respect to the center of the pleated blind. Accordingly, the pleated blind may be sized in four distinct steps. First one end of the head rail and bottom rail are sized to the final width of the pleated shade. Second, one end of the pleated material is sized. Third, the other end of the head rail and bottom rail is sized. Fourth, the other end of the pleated material is sized.

The steps for removing the cutting center **10** from the bay **14**, and accessing the cutting center **10** is the same as that described above for sizing the mini-blind products. Additionally, the first cutting station **16** is moved to the first position to size the pleated shade product. This is the same position as when the metal mini-blind product is being sized.

As with the mini-blind products discussed above, the bottom rail of the pleated shade includes an aperture which is located on pin **64** of pin locator **48**. In contrast to the front pin **62** utilized to locate the mini-blind products, the rear pin **64** is utilized to locate the pleated or cellular shade. By using the half scale indicia of the first scale **70**, the pin locator **48** is aligned with the finished dimension of the customer's specification.

The first end of the head rail and bottom rail are slid into channels **132**, **134** respectively and openings **164**, **166** of the movable die **106**. The pleated material however, is not slid into any opening at this time, but rather the pleated material is slid relative to the bottom rail and head rail, so that one end of the pleated material extends past the second end of the head rail and bottom rail. The first cutting station **16** is activated as discussed above with respect to the mini-blind products.

After the first ends of the pleated head rail and bottom rail are sized, the pleated material is slid into openings channels **132**, **134** of the stationary die **104** and openings **164**, **166** of the movable die **106**. The dimension of the guide die plate **108** proximate opening **140** does not permit the head rail and bottom rails to pass into opening **140** and is stopped a predetermined distance from the cutting plane. In the preferred embodiment, the distance from the ends is one inch. The end locator is used to size the pleated material. The end locator set block **100** received between the pleated shade bottom rail and head rail such that the set block **100** pushes the pleated material forward the sized end of the bottom rail and head rail a predetermined distance. In the preferred embodiment, the set block extends one inch from the first side of the end locator extension to compensate for the one inch distance the bottom rail and head rails are short of the cutting plane **88**. In this

11

manner when the pleated material is sized by blade **174** the width of the pleated material is the same as the width of the head rail and bottom rail.

The process is repeated on the second ends of the pleated shade head rail, bottom rail and pleated material. Where the head rail and bottom rail are not symmetric the second ends of the head rail and bottom rail will not fit in channels **132**, **134**. The second ends of the head rail and bottom rail must be inserted into channels **136**, **138** respectively, that are configured to accommodate the different orientation of the second ends of the pleated shade bottom rail and head rail.

Alternatively, the stock pleated shade product may be sized in three steps. First the head rail and bottom rail may be sized by cutting material off from a single end to the final width of the customer's specification. Since the head rail and bottom rail are being sized from one end only, a full scale may be utilized to locate the head rail and bottom rail relative to the cutting plane. The pleated material is then cut equally on both sides in two separate cutting operations so that the lift cords remain symmetric about the center of the head rail and bottom rail.

Referring to FIGS. **25** and **26**, the sizing of the cellular product in two steps is illustrated. In the first step the entire portion to be removed from the stock cellular head rail and bottom rail is removed in a single operation of the movable die **106** (FIG. **8**). Accordingly, the cellular shade may be located relative to a cellular scale **202** having full scale indicia such that the markings on the scale **202** (FIG. **4**) reflects the actual distance from the cutting plane **88**. The end locator **52** is utilized to locate the cellular product to be sized. The head rail and bottom rail of the cellular product are inserted into channels **132**, **134** (FIG. **8**) while the other ends of the head rail and bottom rail that are not to be sized are located against the first side of the end locator **52**. The first side of the end locator **52** is aligned with the full scale indicia of scale **202** corresponding to the actual width of the blind as requested by the customer. When the head rail and bottom rail are being sized the cellular material is slid away from the ends of the blind to be cut off and towards the second cutting station **18**. The cellular material is allowed to pass through end locator **52** extension **94** via opening **102**.

Once the head rail and bottom rail have been cut to size, the cellular material is slid past the newly cut ends of the head rail and bottom rail into openings **140** and **172** of the stationary and movable dies **104**, **106** (FIGS. **8**, **9**) respectively. The end locator set block **100** pushes the cellular material the required distance into the first cutting station to ensure that the cellular material will have the same width as the head rail and bottom rail once it is sized. The set block **100** is utilized the same way for the cellular material as for the pleated material discussed above.

Referring to FIGS. **12-16** the second cutting station **18** includes a vertical head rail shearing mechanism **204** and a wooden blind sizing mechanism **206**. Vertical shearing mechanism **204** includes a stationary die **208** having a channel **210** for receiving a head rail of a vertical blind product. The stationary die **208** includes a second opening **211** for receiving the traverse rod of the vertical blind product. A movable die **212** moves relative to the stationary die **208** in a vertical up/down direction. Movable die **212** includes a shearing portion **214**. Additionally, vertical shearing mechanism **204** includes a punch **216** that punches a hole in the base of the vertical blind head rail a set distance from the cut end of the head rail as described below. A vertically oriented piston **217** moves the movable die **212** upward and downward as illustrated in FIGS. **13** and **14** respectively.

12

Turning to FIGS. **12**, **15** and **16**, the wooden blind sizing mechanism **206** includes a circular saw **218** having a circular blade **220** that moves from a first position proximate the rear wall **34** to an extended position in the cross housing direction toward the front wall **28**.

The sizing of a wooden blind having a metal head rail, a wooden bottom rail and wooden slats will now be described. While a pin locator **48** could be used to locate the wooden blind for sizing, the center clip locator **50** will be described in connection with the sizing of the wooden blind. As illustrated in FIGS. **22** and **23**, a head rail includes an opening **86** that receives a protrusion or tab extending from clip **80**. In this manner the clip is positively located on the center of the head rail **82**. The clip **80** is then positioned within slot **78** of the center clip locator **50**, which positions the clip and the head rail relative to the second half scale **76**. A pointer **74** on the center clip locator identifies the center position of the wooden blind to be sized relative to the cutting plane **92** of the circular saw **218**.

Once the head rail and clip are located within the slot of the center clip locator, the wooden blind bottom rail, slats and head rail are slid into a first opening **221** in the second cutting station (See FIG. **28**). The wooden blind is located by moving the center clip locator **50** to align the pointer **74** of the center slat locator with the customer's width specification on the second scale **76**.

Once the wooden mini-blind is at the proper location to be sized, the end locator **52** is used to square the ends of the head rail, slats and bottom rail, by using the second side extension second side **98**. A clamp mechanism **222** clamps the bottom rail, the wooden slats and the head rail against a stop **224** (See FIG. **29**) such that the sides of the rails and slats are parallel to the top working surface **36**. This removes any space distance between the slats, the bottom rail and the head rail.

Once the bottom rail, slats and head rail have been located within the opening **221** and clamped against the stop **224**, the first end of the wooden mini-blind is ready to be sized. As with the first cutting station **16**, the operator first enters the access code in the center access panel **22** to allow activation of the second cutting station **18**. To activate the sequence for sizing the wooden blind bottom rail, slats and metal head rail, the operator turns on the second cutting station **18** with the on/off switch. By simultaneously depressing two activation buttons, the following sequence is activated. First the vacuum **46** is started and the circular saw **218** is activated and moved toward the front wall **28** along cutting plane **92** cutting the bottom rail, slats and head rail until the bottom rail, all of the slats, and the head rail are each sized. The circular saw **218** is then moved rearward until it is in its fully withdrawn position. In the preferred embodiment the movement of the saw is automated and controlled by the controller **22**.

In addition to wooden slats, the circular saw **218** may also size faux wood slats made of a cellulose plastic formulation or of slats made from a plastic material, or any other type of material that can effectively be sized with a circular saw. The circular saw **218** includes a circular saw blade **220** that travels along a cutting path **92**.

It is also possible to size a valance for the wooden blind at the same time the head rail, bottom rail and slats are being sized. The valance is simply located adjacent the head rail or bottom rail and sized along with the other components.

A vertical blind may also be sized in the second cutting station **18**. A vertical blind head rail is sized in the vertical shearing mechanism **204** by locating the vertical blind head rail in the vertical blind head rail channel **210**. The vertical blind traverse rod is located within the traverse rod opening **211**. Since the vertical blind; does not include lift cords, the

vertical blind head rail may be sized by removing material from a single side of the stock head rail. Accordingly, a scale 225 (FIG. 4) having full scale indicia are used to determine the width of the vertical blind. Again, the width of the vertical blind is measured to correspond to the width of the window it will be covering. The cutting plane of the vertical shearing mechanism 204 is not in the same plane as the cutting plane 92 of the circular saw. The vertical shearing mechanism is set inward in the housing to permit the circular saw to fully extend along its cutting plane 92 without contacting the shearing mechanism. The scale 225 measures the actual distance to the cutting plane of the vertical shearing mechanism 204.

The vertical shearing mechanism 204 also includes a punch 216 to place an aperture in the base of the vertical head rail a set distance from the cutting plane of the vertical shearing mechanism 204. The aperture is located a predetermined distance from the cut end of the head rail to receive a portion of a snap-in end cap to be added to the vertical head rail once it has been sized. The aperture could also be used to receive a fastener such as a screw to secure an end cap to the head rail. Punch 216 is pivotally connected to a lever 228 that is pivotally connected to the vertical shearing mechanism 204. The lever 228 is pivotally connected to a head portion 230 of a rod 232 which is slidably located in a holder 234 attached to the movable die 212. The head portion 230 includes a base portion having a diameter larger than the rod 232 and larger than the opening in the holder 234.

The operation of the vertical shearing mechanism 204 for sizing the vertical blind head rail will now be described. Since the vertical blind head rail can be sized by removing material on one side of the head rail, no centering locating mechanism need be used. Rather, the vertical blind head rail can be measured by use of the full scale indicia on scale 225. The end of the vertical blind head rail to be cut is placed in channel 210 and the traverse rod is placed in opening 211. The free end of the head rail that is not being sized is aligned with the full scale indicia indicating the customer's specification for the desired width of the vertical blind product. The vertical slats will be sized to a different measurement, since the important feature of the vertical slats is their vertical length when they are placed over a window. Once the vertical blind head rail and traverse rod are located in the stationary die 208 the operator activates the shearing mechanism by following the steps outlined above of inputting the access code, turning the on/off switch to the on position for the second machine cutter, and depressing the two activation buttons.

The movable die 212 will move in an upward direction until the "v" shaped shearing portion 214 contacts and shears the vertical head rail and the traverse rod. Once the holder contacts the base of the head portion 230, the head portion is moved upward, thereby causing the pivot of lever 228 about its pivot point and causing the punch 216 to extend downwards through the head rail. In this manner, an opening is formed in the vertical head rail a predetermined distance from the sheared end of the vertical head rail.

Once the movable die has reached its fully extended upward position and the head rail and traverse rod have been sheared and the opening has been punched in the head rail, the movable die is retracted downward to the starting position. The vertical blind slats may also be sized in the second cutting station 18 to a customer's specifications. The vertical slats extend in a vertical position and therefore are likely to have a dimension different than the head rail width. The vertical slats are clamped down onto top working surface 36 with a vertical clamp 236 (See FIG. 30) such that the face of the vertical slats are parallel to the top working surface 36. If the vertical blind head rail is longer than the space between the first and second

cutting stations 16, 18, the first cutting station 16 may be lowered to a third position as discussed above to allow the vertical head rail to rest horizontally on the top working surface 36. When the first cutting station 16 is lowered to the third position, the top of the frame 178 is substantially flush with or lower than the top working surface. The scale extension 180 is located in housing 20 and extends the full scale 226 (FIG. 4) that measures the actual distance to the cutting plane 92.

Unlike the wooden mini-blind product in which the bottom rail, slats and head rail are all positioned relative to the second cutting station together, the vertical head rail and vertical slats are positioned and sized separately.

In another embodiment, each scale is used for sizing a specific blind or shade product. Further, each scale may have a separate distinct color that corresponds with the color of the packaging for respective blind or shade product to be sized. As a result, an operator will be able to determine which scale to use to size the stock blind or shade product by matching the color of the stock blind or shade packaging with the appropriate scale. The instructions that are located on the housing may also be in color to further reduce the chance that the particular stock blind or shade product is sized incorrectly. Additionally, the instructions that are located in an instruction manual may also be color coordinated with the scale and stock product packaging. Since the scale, packaging for the blind or shade product and instructions all share the same color for sizing of a specific product, the chance of error decreases, resulting in an easier process for the operator.

In a further embodiment, the locator pin may be eliminated. The blind or shade product may include a mark or feature that is located on its longitudinal center. This mark or feature would be aligned with the appropriate marking on the appropriate scale as discussed above. While the locator devices provide for a positive placement of the blind or shade product, it is possible to locate the center of the blind or shade product by means of a mark such as a line placed on the product in the factory before being shipped to the retail outlet. Of course the mark could also be placed by the operator in the retail outlet as well prior to sizing.

The stock blind or shade product would also have a feature such as an indentation, groove or protrusion on the center of the blind that could be used to locate the stock blind or shade product relative to the scale.

While the detailed drawings, specific examples and particular formulations given describe exemplary embodiments, they serve the purpose of illustration only. The systems shown and described are not limited to the precise details and conditions disclosed. Furthermore, other substitutions, modifications, changes, and omissions may be made in the design, operating conditions, and arrangement of the exemplary embodiments without departing from the scope of the invention as expressed in the appended claims.

We claim:

1. A sizing center for sizing a first type of window covering comprising a first material and/or a first configuration and a second type of window covering comprising a second material and/or a second configuration, each window covering including a color marking on packaging of the window covering that corresponds to the type of the window covering, the apparatus comprising:

a first sizing mechanism and a second sizing mechanism disposed on the sizing center and the first sizing mechanism comprising a first die assembly having a first fixed die and a first moveable die sized to cut the first type of window covering but to not cut the second type of window covering and the second sizing mechanism com-

## 15

prising a second die assembly having a second fixed die and a second moveable die sized to cut the second type of window covering but to not cut the first type of window covering, and the first moveable die defining a first cutting direction and the second moveable die defining a second cutting direction, wherein the first cutting direction is perpendicular to the second cutting direction; the second sizing mechanism further comprising a punch and a circular saw;

at least a first measuring scale positioned on the sizing center relative to the first cutting direction and at least a second measuring scale positioned on the sizing center relative to the second cutting direction, the first measuring scale being associated with the first sizing mechanism and having a first color and the second measuring scale being associated with the second sizing mechanism and having a second color where the second color is different than the first color; each of the first color and the second color corresponding to a color marking on packaging of a window covering, the color marking corresponding to the type of the window covering, thereby enabling a user to determine an appropriate measuring scale based solely on the color marking.

## 16

2. The apparatus of claim 1, wherein the first measuring scale includes half-scale indicia.
3. The apparatus of claim 1, further comprising a slidable carrier, wherein the slidable carrier includes a protrusion adapted to engage the window covering.
4. The apparatus of claim 3, wherein the carrier includes a pointer adapted to point to a measuring scale.
5. The apparatus of claim 1, wherein the sizing center has a left end and a right end, and the first sizing mechanism is disposed on the right end, and the second sizing mechanism is disposed on the left end.
6. The apparatus of claim 1, wherein the sizing center has a first end and a second end, and the first sizing mechanism and the second sizing mechanism are disposed on the first end.
7. The apparatus of claim 1, further including instructions for sizing different types of window covering in a color that corresponds to the scale and the color marking on the respective different types of window covering.

\* \* \* \* \*