

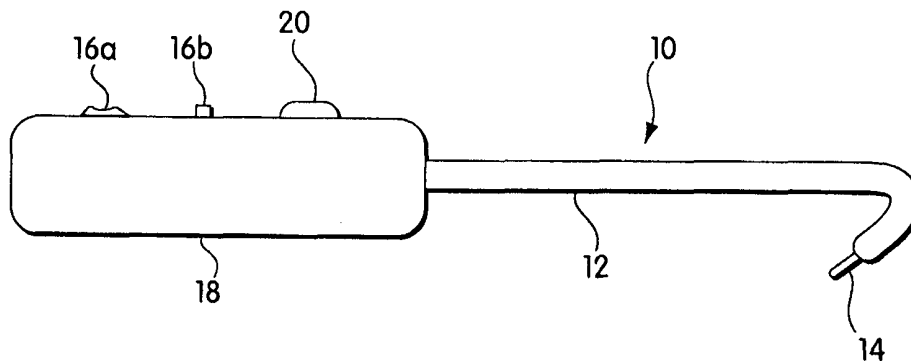

## INTERNATIONAL APPLICATION PUBLISHED UNDER THE PATENT COOPERATION TREATY (PCT)

<p>(51) International Patent Classification <sup>7</sup> : A61M 31/00, A61K 48/00</p>	<p>A1</p>	<p>(11) International Publication Number: <b>WO 00/16848</b></p> <p>(43) International Publication Date: 30 March 2000 (30.03.00)</p>
<p>(21) International Application Number: PCT/US99/22392</p> <p>(22) International Filing Date: 24 September 1999 (24.09.99)</p> <p>(30) Priority Data: 09/159,834 24 September 1998 (24.09.98) US</p> <p>(71) Applicant: C.R. BARD, INC. [US/US]; 730 Central Avenue, Murray Hill, NJ 07974 (US).</p> <p>(72) Inventor: CAFFERATA, Robert, L.; 55 Warwick Road, Belmont, MA 02178 (US).</p> <p>(74) Agent: PERULLO, John, F.; Kirkpatrick &amp; Lockhart LLP, 75 State Street, Boston, MA 02109-1808 (US).</p>	<p>(81) Designated States: AE, AL, AM, AT, AU, AZ, BA, BB, BG, BR, BY, CA, CH, CN, CU, CZ, DE, DK, EE, ES, FI, GB, GD, GE, GH, GM, HR, HU, ID, IL, IN, IS, JP, KE, KG, KP, KR, KZ, LC, LK, LR, LS, LT, LU, LV, MD, MG, MK, MN, MW, MX, NO, NZ, PL, PT, RO, RU, SD, SE, SG, SI, SK, SL, TJ, TM, TR, TT, UA, UG, UZ, VN, YU, ZA, ZW, ARIPO patent (GH, GM, KE, LS, MW, SD, SL, SZ, TZ, UG, ZW), Eurasian patent (AM, AZ, BY, KG, KZ, MD, RU, TJ, TM), European patent (AT, BE, CH, CY, DE, DK, ES, FI, FR, GB, GR, IE, IT, LU, MC, NL, PT, SE), OAPI patent (BF, BJ, CF, CG, CI, CM, GA, GN, GW, ML, MR, NE, SN, TD, TG).</p> <p><b>Published</b> <i>With international search report. Before the expiration of the time limit for amending the claims and to be republished in the event of the receipt of amendments.</i></p>	

(54) Title: SYSTEMS AND METHODS FOR TREATING ISCHEMIA



## (57) Abstract

A system and method for implanting pellets into myocardial tissue for treatment of coronary artery restenosis, ischemic heart disease, or cardiac conduction of disturbances. The mechanism of delivery can be transcatheter via chambers of the heart, endoscopic pericardial approach via minimally invasive transthoracic access, or intraoperative pericardial approach during open-chest surgery. Noncardiac tissues can also be treated.

**FOR THE PURPOSES OF INFORMATION ONLY**

Codes used to identify States party to the PCT on the front pages of pamphlets publishing international applications under the PCT.

AL	Albania	ES	Spain	LS	Lesotho	SI	Slovenia
AM	Armenia	FI	Finland	LT	Lithuania	SK	Slovakia
AT	Austria	FR	France	LU	Luxembourg	SN	Senegal
AU	Australia	GA	Gabon	LV	Latvia	SZ	Swaziland
AZ	Azerbaijan	GB	United Kingdom	MC	Monaco	TD	Chad
BA	Bosnia and Herzegovina	GE	Georgia	MD	Republic of Moldova	TG	Togo
BB	Barbados	GH	Ghana	MG	Madagascar	TJ	Tajikistan
BE	Belgium	GN	Guinea	MK	The former Yugoslav Republic of Macedonia	TM	Turkmenistan
BF	Burkina Faso	GR	Greece	ML	Mali	TR	Turkey
BG	Bulgaria	HU	Hungary	MN	Mongolia	TT	Trinidad and Tobago
BJ	Benin	IE	Ireland	MR	Mauritania	UA	Ukraine
BR	Brazil	IL	Israel	MW	Malawi	UG	Uganda
BY	Belarus	IS	Iceland	MX	Mexico	US	United States of America
CA	Canada	IT	Italy	NE	Niger	UZ	Uzbekistan
CF	Central African Republic	JP	Japan	NL	Netherlands	VN	Viet Nam
CG	Congo	KE	Kenya	NO	Norway	YU	Yugoslavia
CH	Switzerland	KG	Kyrgyzstan	NZ	New Zealand	ZW	Zimbabwe
CI	Côte d'Ivoire	KP	Democratic People's Republic of Korea	PL	Poland		
CM	Cameroon	KR	Republic of Korea	PT	Portugal		
CN	China	KZ	Kazakstan	RO	Romania		
CU	Cuba	LC	Saint Lucia	RU	Russian Federation		
CZ	Czech Republic	LI	Liechtenstein	SD	Sudan		
DE	Germany	LK	Sri Lanka	SE	Sweden		
DK	Denmark	LR	Liberia	SG	Singapore		
EE	Estonia						

## SYSTEMS AND METHODS FOR TREATING ISCHEMIA

### Field of the Invention

The invention relates to the local delivery of therapeutic agents, and more particularly, to systems and methods that deliver depots of therapeutic agents into a body of tissue to allow for the treatment of a variety of conditions, including coronary conditions and cardiovascular indications.

### Background of the Invention

Disease, injury and surgery can result in localized tissue damage and morbidity. For example, the principal treatment for occlusive vascular diseases is angioplasty, a procedure in which a balloon is inserted into the vessel and then inflated to dilate the area of narrowing. During inflation, the balloon can damage the vessel wall. It appears that as a result of this damage, in 30 to 50% of cases, the initial increase in lumen dimensions is followed by a localized re-narrowing (restenosis) of the vessel over a time of three to six months. Thus, restenosis can result in the dangerous and localized renarrowing of a patient's vessel at the site of the recent angioplasty. Like many other localized diseases, restenosis is complex and at present there is no clinically effective treatment for this disease. Gibbons *et al.*, *Molecular Therapies for Vascular Diseases*, Science vol. 272, pages 617-780 (May 1996).

Restenosis, like many other localized injuries and diseases, has responded poorly to pharmacological therapies and agents. Numerous pharmacological agents have been clinically tested, and none have demonstrated an unequivocal reduction in the incidence of restenosis. However, the failure of these pharmacological therapies may arise from the systemic intolerance of the doses required to achieve local beneficial effects or in the difficulty of providing controlled administration of proper dosages over time.

Accordingly, one possible reason for the failure of these therapies is that submaximal

5 doses of pharmacological agents are being administered to avoid the serious side-effects that might result from systemic administration of the proper dosage.

10 To address this problem, various researchers have proposed methods for site-specific delivery of pharmacologic and molecular therapies. These methods include the direct deposition of therapeutic agents into the arterial wall through an intravascular delivery system, systemic administration of therapeutic agents that have a specific affinity for the injured or diseased tissue, and systemic administration of inactive agents followed by local activation.

15 At present, systems exist that attempt to achieve localized delivery of therapeutic agents. These systems include dual balloon delivery systems that have proximal and distal balloons that are simultaneously inflated to isolate a treatment space within an arterial lumen. A catheter extends between the two balloons and includes a port that can admit within the treatment space between the balloons an aqueous medium, typically one  
20 containing a therapeutic agent. Pressure can be applied to the medium to create conditions conducive to intramural infusion. Other balloon-based localized delivery systems include porous balloon systems, hydrogel-coated balloons and porous balloons that have an interior metallic stent. Other systems include locally placed drug-loaded coated metallic stents and drug-filled polymer stents. Wilensky *et al.*, *Methods and*  
25 *Devices for Local Drug Delivery in Coronary and Peripheral Arteries*, Trend Cardiovasc Med, vol. 3 (1993).

30 Although these systems can provide working devices for local drug delivery, the efficacy of these devices turns on, and is limited by, a number of factors including the rate of fluid flux through the vascular wall, the residence time of the deposited agent and the local conditions and vasculature of the deposition site. Essentially, the success of these systems is limited by the amount of time that a delivered drug will stay resident locally before being carried downstream by circulating blood. Further, to the extent that these systems allow the therapeutic agent to be carried away, these systems run the risk of  
35 applying a therapeutic agent to areas of the patient's vasculature where such agents may

5 not be beneficial. Additionally, these existing systems are limited by the amount of drug that can be delivered to the diseased site. Moreover, drug filled polymer stents have structural problems that argue against their use.

10 Existing systems for local drug delivery, including direct deposition of therapeutic agents through an intravascular delivery system, systemic administration of therapeutic agents that have a specific affinity for the injured or diseased tissue, and systemic administration of inactive agents followed by local activation, all require a functioning vascular system for delivery of the therapeutic agent to the affected tissue. These systems, therefore, are inapplicable in conditions characterized by myocardial ischemia or  
15 infarction. When ischemic injury is of sufficient severity and duration, groups of involved cells die and myocardial infarction results. Within the ischemic area, not all cells are equally injured. As ischemia persists, there is wave-like progression of cell death or coagulation necrosis. The prospect for recovery decreases with increasing duration or severity of the ischemic insult. It is difficult to quantitate the extent to which ischemic  
20 injury will result in cell necrosis.

Reperfusion can salvage injured tissue even after some cells have become necrotic. However, following reperfusion, cells that have been already injured are particularly vulnerable to further injury. This phenomenon, termed "reperfusion injury," paradoxically  
25 results in cellular necrosis when circulation returns to a cell population that survived the initial ischemic insult. Many factors contribute to this situation. The endothelium of vessels in the reperfused region have been damaged, causing platelet adherence and leukocyte activation with inflammatory sequelae. Oxygen free radicals are released by damaged cells, causing further cell and organelle damage. The sodium-potassium pump,  
30 damaged with the initial ischemia, can lose its regulatory ability and allow free water accumulation during reperfusion, resulting in cell swelling and rupture. Unstable and leaky cell membranes can also lead to calcium accumulation within the cytoplasm with uptake of calcium into mitochondria and formation of insoluble calcium-phosphate crystals. As a consequence, there may be a population of cells killed by the initial  
35 ischemic insult, and a further population killed following reperfusion.

5 Both ischemia and infarction can adversely affect myocardial contractile function. The more extensive the injury, the more severe its impact on ventricular function. Following severe myocardial ischemia, there may be a reversible hypocontractile state called "hibernation," a condition of impaired contractility amenable to recovery (the so-called "stunned" myocardium, and frank myocardial infarction, characterized by cell  
10 death. Once a population of myocytes becomes necrotic, the injured tissue cannot regenerate itself; mature myocytes lack the capacity for cellular replication. The contribution these necrotic myocytes made to contractile function is, thus irreversibly lost. Restoration of functioning myocardium after frank infarction requires both a restoration of tissue perfusion and a replenishing of viable cells that can assume the  
15 contractile role of the infarcted tissues.

In view of the variety of localized cardiovascular conditions affecting human health, it would be advantageous to develop other methods of treatment for patients having localized cardiovascular conditions and in particular to develop methods of  
20 treatment that reduce adverse side effects and have heightened efficacy. It would furthermore be advantageous to permit treatment of localized cardiovascular conditions resulting from myocardial ischemia and myocardial infarction through local delivery of therapeutic agents.

#### 25 Summary of the Invention

It is therefore, an object of the invention to provide methods of treatment of a coronary artery or cardiac indication that provide a longer duration of drug pendency at the site of a localized disease.

30 It is a further object of the invention to provide systems and methods that reduce or eliminate the downstream flow of a locally delivered agent.

It is a further object of the invention to provide delivery of local therapeutic agents to areas of impaired vascularity.

35

5           It is yet a further object of the invention to allow improvement of contractile function in infarcted myocardial tissue.

          Other objects of the invention will, in part, be obvious, and, in part, be shown from the following description of the systems and methods shown herein.

10           To these ends, the invention provides systems and methods for implanting a depot into a tissue wall to thereby deliver a therapeutic agent selected for the condition being treated. In one embodiment, the invention provides systems and methods for delivering a therapeutic agent into the myocardial tissue wall for treating various vascular conditions including restenosis, ischemic tissue, and myocardial infarction. Other applications of the systems and methods described herein include the delivery of angiogenesis compounds that can be implanted into ischemic tissue; and/or antiarrhythmic drugs that can be implanted at the sites of conduction abnormalities. A further application of the systems and methods described herein includes the delivery of cells for implantation into the myocardium, accompanied by angiogenesis compounds that will promote local circulation. Accordingly, the agent being locally delivered can depend on the application at hand, and the term agent, or therapeutic agent, as employed herein will be understood to encompass any agent capable of being locally delivered including, but not limited to, pharmaceutical compositions or formulations, viral or non-viral vectors (e.g., adenovirus vectors, retroviral vectors and the like), implantable (genetically engineered) cells, plasmid-liposome complexes or other DNA delivery complexes, oligonucleotides or any other suitable composition compatible with the subject being treated.

20           In one embodiment, the invention provides systems and methods for local delivery of at least two therapeutic agents, one of which promotes angiogenesis and the other of which contains cells adapted for implantation into the myocardium. The therapeutic agent that promotes angiogenesis can include any substance that induces the formation of blood vessels, including but not limited to such substances as vascular endothelial growth factor (VEGF), tumor angiogenesis factor (TAF), tumor necrosis factor (TNF), fibroblast growth factor (FGF), wound angiogenesis factor (WAF), other growth factors, and other

5 substances including but not limited to angiogenin, fibrin, prostaglandin E and heparin. Cells adapted for implantation into the myocardium include, but are not limited to, cardiomyocytes and their precursors, skeletal myoblast-derived cells, fibroblasts, genetically modified fibroblasts and bone marrow stromal cells and their derivatives. Cells adapted for implantation into the myocardium can be subjected to genetic  
10 manipulation prior to or subsequent to implantation.

In a further embodiment, the invention is understood as an apparatus for delivering therapeutic agents into the myocardium. These apparatus can comprise an outer mechanical element made of a biocompatible material which promotes angiogenesis  
15 locally by its contact with the myocardial tissues and further comprising an inner reservoir adapted for delivering cells adapted for implantation in the myocardial tissue. In another embodiment, the inner reservoir contains molecular ligands that possess specific affinity for the cell surface markers on circulating myocyte precursor cells, so that these cells are affixed within the reservoir and subsequently released. In a further embodiment, the  
20 biocompatible material of the apparatus comprises a drug releasing compound capable of releasing at least one therapeutic agent. In yet another embodiment, this therapeutic agent is capable of promoting angiogenesis. In a further embodiment, this apparatus is bioresorbable.

25 The invention can also be understood to include apparatus for delivering at least two therapeutic agents comprising a body formed of a biocompatible material containing at least one reservoir permeable to at least one therapeutic agent. The biocompatible material of the delivery system can include a drug releasing compound capable of releasing at least one therapeutic agent. Therapeutic agents released by the drug  
30 releasing compound include, but are not limited to, those capable of promoting angiogenesis. In another embodiment, at least two therapeutic agents are disposed within separate reservoirs, each reservoir permeable to the therapeutic agent within it. In a further embodiment, this apparatus is bioresorbable.



5           The apparatus can comprise an elongate flexible body having a proximal end and a distal end, a delivery chamber coupled to the distal end of the body and having a space for carrying the therapeutic agent, and a port for releasing the therapeutic agent therefrom. The apparatus can further include an actuator coupled to the distal delivery chamber and being capable of driving therapeutic agent through the port.

10           The terms proximal and distal as used herein will be understood to describe opposite ends of a device or element, and generally will be employed so that proximal is understood as "away from the heart" and distal is understood as "towards the heart" or to mean "toward the physician" and "away from the physician" respectively.

15           Brief Description of the Figures

          The foregoing and other objects and advantages of the invention will be appreciated more fully from the following further description thereof, with reference to the accompanying drawings wherein;

20           FIG. 1 depicts one embodiment of a catheter having a delivery chamber carried at the distal end;

          FIGS. 2A and 2B depict in more detail the delivery chamber of the catheter depicted in FIG. 1;

          FIGS. 3A and 3B depict an alternative delivery chamber for use with the catheter of FIG. 1;

30           FIGS. 4A and 4B depict two embodiments of pellets suitable for implantation by the catheter of FIG. 1;

          FIG. 5 depicts one method for delivering a therapeutic agent to the myocardium;

5 FIG. 6 provides a cross-cut perspective of a coronary artery extending through the myocardium and having pellets of therapeutic agent disposed around the artery; and

FIG. 7 depicts a local drug delivery device having a pistol grip and being suitable for use during an endoscopic procedure.

#### Detailed Description of the Illustrated Embodiments

10 To provide an overall understanding of the invention, the methods and devices illustrated herein are described with reference to the application of treating cardiac indications by implanting drug delivery pellets into myocardial tissue for the treatment of  
15 coronary artery restenosis, ischemic heart disease, cardiac conduction disturbances and other similar conditions. However, it will be understood that the systems and methods described herein are applicable to any condition that can benefit from the implanting of a depot of a therapeutic agent, and the invention is not to be limited to the applications illustrated herein. For example, the techniques herein are directly applicable for  
20 implanting therapeutic agents to stimulate angiogenesis. The techniques herein are also directly applicable to the methods for delivering therapeutic agents to infarcted myocardium where these therapeutic agents include substances for promoting angiogenesis and cells adapted for implantation in the myocardium. The techniques herein are further applicable to the manipulation of the cellular environment following  
25 ischemic injury, either to protect against reperfusion injury or to enhance recovery in the stunned myocardium.

The depot implanting systems illustrated herein include catheter systems for delivery via the chambers of the heart, endoscopic systems for pericardial approach via  
30 minimally invasive trans-thoracic access, and systems for use during intraoperative pericardial approach during open-chest surgery. In one practice, the devices deliver a plurality of pellets that surround, or partially surround, an artery being treated. This is understood to achieve the effect of implanting a drug-filled ring around the artery. The pellets remain in the myocardial tissue, and can give off drug(s) for a selected time period  
35 and then be absorbed by the body. The systems described herein can implant pellets that

5 contain radio-opaque markers to facilitate viewing the pellets by fluoroscopy during catheter delivery.

Fig. 1 depicts one embodiment of a system for providing local delivery of a therapeutic agent. The delivery device 10 includes a catheter 12, a delivery chamber 14,  
10 steering switches 16a and 16b, a handle 18, and a delivery control switch 20.

The depicted system 10 is a catheter system that can be guided through vascular access at the femoral artery or vein of a patient until the delivery chamber 14 enters into the interior chambers of the patient's heart to implant a depot of drug within the  
15 myocardium. To that end, the catheter 12 which extends between the delivery chamber 14 and the handle 18 can be approximately 175 cm to 200 cm in length and can include an elongated rotationally rigid, longitudinally flexible body optionally made of woven polyester fibers, stainless steel wires, thermoset or thermoplastic polymers or any other material suitable for use as a catheter shaft. The catheter can have a substantially uniform  
20 diameter of approximately 0.025 to 0.100 inches (.62 to 2.5 mm).

In the embodiment depicted in Fig. 1, the catheter 12 is a steerable catheter that allows or facilitates the guiding of the catheter through the patient's vasculature and into the chamber of the patient's heart. Further, the steerable catheter 12 allows the physician  
25 to bend the catheter once the catheter has entered into the interior of the heart, to thereby position the delivery chamber 14 adjacent the area of the endocardial wall through which the delivery chamber is to penetrate. The steering capability of the catheter 12 is illustrated by the bend located at the distal end of the catheter 12. Steering catheters suitable for use with the present invention are known in the art, and include steering  
30 catheters employed in Electrophysiology procedures. Electrophysiology catheters typically provide steering through a combination of rotation and tip bending.

One suitable steerable catheter is described in U.S. Patent 5,656,029, which is incorporated herein by reference. This catheter provides an elongate flexible body that  
35 carries a bending mechanism at its distal end. The bending mechanism consists of a

5 shape-memory element typically formed of Nitinol which is provided with a memory  
which makes it assume a straight condition when it is heated, such as by application of an  
electrical current. The shape memory element extends through the distal portion of the  
catheter and is adapted to remain straight along its full length in response to a current  
10 passing through the element. To control the location of the bending, an electrical bypass  
is slidably mounted about the bending element. The bypass element can be an elongate  
cylindrical sleeve formed of a conductive material and through which the bending element  
can extend. The bypass element can act as a short circuit that bypasses current away  
from the bending element. Accordingly, the bypass element prevents current from  
15 heating the bending element at the location of the bypass. Consequently, the bending  
element will bend at the location of the bypass. By allowing the bypass to be slid along  
the length of the bending element, the physician can select the location of the bypass,  
thereby selecting the location of bending. As the delivery chamber 14 is carried at the  
distal extremity of the catheter 12, this allows the physician to selectively position the  
20 delivery chamber 14 within the interior of the patient's heart.

20 The bending elements and bypass elements described above are carried within the  
catheter 12 and are not shown in Fig. 1, but however are described in detail in the above  
identified reference. Additionally, it is noted that although the catheter 12 has been  
described with reference to one type of steerable catheter it will be apparent to one of  
25 ordinary skill in the art that other suitable steering mechanisms can be employed with the  
present invention including steering mechanisms that include actuating poles or wires that  
extend longitudinally through the catheter body. Moreover, it will be further understood  
that although the depicted catheter 12 is optionally a steerable catheter, the devices of the  
invention are not to be limited to steerable devices, and will be understood to encompass  
30 conventional catheter systems as well.

Control of the depicted catheter 12 and the delivery chamber 14 is provided by  
the integrated hand-held control mechanism and handle 18 mounted on the proximal end  
of the catheter 12. The control mechanism/handle 18 can be of various types, and the  
35 depicted handle 18 is adapted for operating a steerable catheter wherein the bend of the

5 catheter can be selectively controlled by the physician. To these ends, the hand-held  
control/handle 18 is dimensionally adapted to provide the treating physician with a device  
that is facile to manipulate and comfortable to hold. Additionally, the hand-held  
mechanism/handle 18 includes a set of control switches, 16a, 16b and 20 that allow the  
10 physician to control the steering of the catheter 12 and the implanting of the depot.  
Switches 16a and 16b can provide steering control for the catheter 12. The switch 16a  
can be a slidable switch that allows the physician to control the longitudinal position of  
the bend within the distal tip of the catheter. The switch 16a can activate the bending  
mechanism to cause the catheter tip to bend as needed. The control switch 20 can  
15 activate the delivery chamber 14 to cause a pellet containing a therapeutic agent to be  
delivered into a tissue wall.

It will be apparent to one of ordinary skill in the art that other control  
mechanisms/handles can be employed with the systems of the invention without departing  
from the scope thereof. Specifically, other systems can include joystick controls for  
20 operating the steerable catheters and can include controls for rotating the angle at which  
the distal end of the catheter bends. Still other control mechanisms/handles can include  
pistol grips for providing manual activation of the delivery chamber 14. Other  
modifications and additions can be made to the control mechanism/handle without  
departing from the scope of the invention.

25 Fig. 2A depicts in greater detail one delivery chamber 14 which is suitable for  
being carried at the distal end of the catheter 12 depicted in Fig. 1. The delivery chamber  
14 is sized to hold the plurality of minispheres 22, each of which contains a therapeutic  
agent. The minispheres 22 are carried within an interior chamber 24 which is bound at  
the proximal end by a plunger 33 and bound at the distal end by a wall formed of a  
0 plurality of flexible finger elements 36 that define a port 30. In the embodiment depicted  
in Fig. 2A, an optional detent 34 is connected to a sidewall of the chamber 24 to provide  
a mechanical stop that prevents the minispheres 22 from freely exiting through the port  
30. Upon application of mechanical force by the plunger 33, the minispheres 22 can be  
pushed over the detent 34, for allowing one minisphere 22 to be ejected through port 30.

5 More specifically, the plunger 33 depicted in Fig. 2A includes a plate 38 and an  
actuating rod 40. The plate 38 is dimensioned to fill substantially the diameter of interior  
chamber 24 to provide thereby a surface that is adapted for forcing the minispheres 22  
through the chamber 24 and out of port 30. The actuating rod 40 is connected to the  
plate 38 and provides a mechanical force to plate 38 to advance, or drive, the plate 38  
10 distally into the chamber 24. In one embodiment, the actuating rod 40 extends through  
the catheter 12 and couples to the control mechanism/handle 18 at the proximal end of  
device 10. In this embodiment, the control mechanism/handle 18 includes a mechanism  
that drives the actuating rod 40 distally causing minispheres 22 to be delivered through  
port 30. Optionally, this embodiment can include a control mechanism/handle 18 that  
15 incorporates a ratchet assembly that drives the actuating rod 40 distally in discreet steps  
wherein a predetermined number of steps corresponds substantially to the diameter of  
one of the minispheres 22. For example, the depicted control switch 20 can be a  
rotatable switch that allows for manual actuation of a ratchet assembly contained within  
the control mechanism/handle 18. The ratchet assembly allows the physician to drive the  
20 plunger 33 distally into the chamber 24 thereby driving the minisphere 22 out of the port  
30. In this way, the device 10 can allow for the discreet and sequential delivery of  
minispheres 22 from the delivery chamber 14.

25 In an alternative embodiment of the invention, the plunger 33 is threaded to mate  
with a threaded interior portion of chamber 24. Manual or motor-driven rotation of  
actuating rod 40 will advance or retract the plunger with a finer degree of control than  
that provided by strictly linear actuation. Such control over the travel distance of the  
plunger 33 into and out of the interior chamber 24, gives control over the number of  
minispheres 22 delivered through port 30.

30 FIG. 2B provides a head-on perspective of the delivery chamber 14, showing the  
distal most portion of the delivery chamber 14 as viewed from a position along the  
longitudinal axis of the delivery chamber 14. Together, FIGS. 2A and 2B show that the  
distal end of the delivery chamber 14 includes a port 30 that is formed from the  
35 convergence of a plurality of flexible arched fingers 36, each of which is formed from a

5 resilient material and each of which is biased to hold the minispheres 22 within the interior chamber 24. Upon action of the plunger 33 to move the minispheres 22 distally, the fingers 36 will yield to the axial pressure and release a minisphere 22. Additionally, in the embodiment depicted in FIG. 2A the optional detent 34 provides further resistance that prevents minispheres 22 from exiting chamber 24 through the port 30 and for  
10 providing a tactile sensation that indicates when a minisphere 22 has been released, or has become available to be released, through port 30.

The delivery chamber 14 is adapted to facilitate the implantation of a depot of drug within a tissue wall. For example the delivery chamber 14 can be sized and made of  
15 a material rigid enough to facilitate the penetration of the delivery chamber within a tissue wall. Accordingly, the depicted delivery chamber 14 can be about 0.010 to 0.050 inches in diameter, and about .05 to .075 inches in length, to have a needle-like profile that is suitable for penetrating tissue. Additionally, the depicted delivery chamber 14 can be formed of stainless steel or of plastic material that is sufficiently rigid to allow the  
20 delivery chamber 14 to pass into a tissue wall.

FIGS. 3A and 3B depict an alternative embodiment of a delivery chamber suitable for use with the catheter system 10 shown in FIG. 1. The depicted delivery chamber 50 includes a cylindrical sidewall 58 that defines an interior space that houses a plunger 52.  
25 The plunger 52 includes a grooved plate 62 that can be rotatably driven along the threads 64 that extend along a portion of the sidewall 58. Accordingly, in this embodiment, the plunger 52 advances into the delivery chamber 50 as the plate 62 turns across, and travels over the threads 64. The distal end of the plunger 52 butts against a stack of nested drug delivery pellets 60 and forces the pellets 60 against the elongate flexible finger elements  
30 54 that, as shown by FIG. 3B, define the port 56.

The delivery chamber 50 implants drug pellets having a hollow, conical shape which facilitates the penetration of the implants 60 into the tissue wall. As shown, the plunger 52 can drive the pellets 60 through the port 56 and into the tissue wall. As  
35 discussed above, the flexible fingers 54 are biased to hold the pellets 60 within the

5 chamber 50, however, the mechanical force applied by the plunger 52 will be sufficient to overcome the bias force of the fingers 54. Again as discussed above, a ratchet assembly, a rotary actuator, and/or optionally a detent, can be employed to help the physician control the number of pellets being delivered into the tissue wall. Specifically, the ratchet assembly or rotary actuator controls the distance the plunger 52 is driven into the chamber 50 and the detent provides a tactile sensation each time a pellet 60 is moved a  
10 predetermined distance.

The delivery chamber 50 provides an alternative embodiment that allows for the implantation of larger pellets of drugs where the size of the pellet may require a delivery  
15 chamber that is too large to readily penetrate through a tissue wall. Accordingly, delivery chambers can be selectively developed for the implantation systems described herein based on the applications of interest and the size of the pellet being delivered. For example, in systems that implant microspheres of drugs having diameters of about 5-15  $\mu\text{m}$ , the delivery chamber can be adapted to hold the microspheres in a fluid medium and a plunger assembly, or other suitable system, can be employed to flush the microspheres  
20 from the delivery chamber and into the tissue wall. In this case, the delivery chamber can be simply a hypodermic needle, and a syringe connected to the proximal end of the system can inject the fluid medium through a lumen in the catheter 12. Other delivery chambers can be employed with the systems described herein without departing from the scope hereof.  
25

The systems described above are capable of implanting pellets that contain a therapeutic agent. The therapeutic agent can be any compound that is biologically active and suitable for long term administration to a tissue or organ. The pellets described  
30 above can be formed as mini-spheres that are on the order of about 0.005 inches to about 0.040 inches in diameter. Particles of this size are capable of providing a therapeutically effective dose of agent and can remain where implanted, resisting fluid flux through the tissue wall.



5 An understanding of the technologies upon which the present invention draws is based on articles in the scientific literature, such as those cited below which are herein incorporated by reference. It is a realization of the present invention that ischemia can be treated by promoting angiogenesis in the ischemic area. It is a further realization of the present invention that the introduction of cardiomyocyte precursor cells into a damaged  
10 area of the myocardium can result in the production of functioning myocardial elements.

Molecular bases for vascular growth and remodeling have been described in the scientific literature. Folkman and D'Amore, *Blood Vessel Formation: What is its Molecular Basis?* Cell vol. 87, pages 1153-1155 (December 27, 1996); Kim *et al.*,  
15 *Inhibition of Vascular Endothelial Growth Factor-induced Angiogenesis Suppresses Tumor Growth In Vivo*, Nature vol. 362, pages 841-844 (April, 1993); Knighton *et al.*, *Wound Healing Angiogenesis: Indirect Stimulation by Basic Fibroblast Growth Factor*, J. Trauma vol. 30, pages S134-S144 (December, 1990). These findings have been applied to the myocardium, showing that increased neovascularization can be induced by  
20 angiogenic therapy. Folkman, *Angiogenic Therapy of the Human Heart*, Circ. vol. 97, pages 628-629 (1998); Schumacher *et al.*, *Induction of Neoangiogenesis in Ischemic Myocardium by Human Growth Factors*, Circ. vol. 97, pages 645-650 (1998). The abovementioned articles, describing the basis for applying the techniques of angiogenesis to the ischemic myocardium, are hereby incorporated by reference. In an area of the  
25 myocardium where the native circulation has been impaired, it is understood that promoting angiogenesis can lead to the ingrowth of new blood vessels and thereby can help restore the level of perfusion needed for effective tissue nutrition.

In light of the fact that mammalian cardiomyocytes are terminally differentiated  
30 early in the development of the heart, it is understood that the myocardium cannot regenerate its muscle cells after myocardial infarction. Smith and Claycomb, *Adult Rat Cardiomyocyte Proliferation Assay*, In Vitro Cell Dev. Biol. vol. 33, pages 428-431 (June, 1997); Parker and Schneider, *Growth Factors, Proto-oncogenes, and Plasticity of the Cardiac Phenotype*, Ann. Rev. Physiol. vol. 53, pages 179-200 (1991). These  
35 articles, incorporated herein by reference, describe the ways in which the functioning

5 myocardium responds to the loss of viable cardiomyocytes following ischemic injury. Terminal differentiation, and the factors that regulate it, are described by Olwin *et al.*, *Are Fibroblast Growth Factors Regulators of Myogenesis In Vivo?* Progress in Growth Factor Research, vol. 5, pages 145-158 (1994), incorporated herein by reference. It has  
10 been further described that transplanted myocytes can be introduced into an area of the myocardium that has been damaged by ischemia or infarction. Li *et al.*, *Cardiomyocyte Transplantation Improves Heart Function*, Ann. Thor. Surg. vol. 62, pages 654-661 (1996). According to this article, incorporated herein by reference, cardiomyocytes are understood to survive and function when placed within an area of injured or necrotic myocardium, or within myocardial scar tissue. It has been further described that  
15 genetically modified cardiomyocytes transplanted into damaged myocardium survive in ischemic areas. Aoki *et al.*, *Survival of Grafts of Genetically Modified Cardiac Myocytes Transfected with FITC-labeled Oligodeoxynucleotides and the Beta-Galactosidase Gene in the Noninfarcted Area but not in the Myocardial Infarcted Area*, Gene Therapy vol. 4, pages 120-127 (1997); Gojo *et al.*, *Transplantation of Genetically Marked Cardiac Muscle Cells*, J. Thorac. Cardiovasc. Surg. vol. 113, pages 10-18  
20 (1997); Gojo *et al.*, *Ex Vivo Gene Transfer into Myocardium Using Replication-defective Retrovirus*, Cell Transplantation, vol. 5, pages S81-S84 (1996). These articles, incorporated herein by reference, further teach the possibility of genetic modification of cells implanted within the myocardium whereby the implanted cells would express factors that would contribute to the clinical treatment of the damaged area. Growth factors  
25 expressed by genetically modified cells are understood to produce angiogenesis in vivo. Ueno *et al.*, *Adenovirus-Mediated Expression of the Secreted Form of Basic Fibroblast Growth Factor (FGF-2) Induces Cellular Proliferation and Angiogenesis In Vivo*, Arterioscler. Thromb. Vasc. Biol. vol. 17, pages 2453-2460 (1997).

30  
35  
Cardiomyocytes introduced into damaged myocardium are understood in the following articles, incorporated herein by reference, to improve cardiac function. Jia *et al.*, *Transplanted Cardiomyocytes Survived in Scar Tissue and Improved Heart Function*, Cell Transplantation vol. 5, page 42 (1997); Li *et al.*, *Natural History of Fetal Rat Cardiomyocytes Transplanted into Adult Rat Myocardial Scar Tissue*, Circ. vol. 96,

5 Supp. II, pages 179-187 (1997). It is further understood, however, that other cells besides cardiomyocytes can be introduced into the damaged myocardium and will differentiate into cells that function like cardiomyocytes. Sources of cells, include the skeletal muscle satellite cells and cells from the bone marrow, are described in the following articles, incorporated herein by reference. Chiu *et al.*, *Cellular*  
10 *Cardiomyoplasty: Myocardial Regeneration with Satellite Cell Implantation*, Ann. Thorac. Surg. vol. 60, pages 12-18 (1995); Ferrari *et al.*, *Muscle Regeneration by Bone Marrow-derived Myogenic Progenitors*, Science vol. 279, pages 1528-1530 (March 6, 1998); Pennisi, *Bone Marrow Cells May Provide Muscle Power*, Science vol. 279, page 1456 (March 6, 1998). According to these publications, non-cardiomyocytes can be  
15 induced to differentiate into cells with structure and function analogous to cardiomyocytes, thus making a variety of cells available for transplantation into the damaged myocardium with the anticipation of functional benefit.

20 Methods described in the abovementioned publications for introducing cells into the myocardium have been substantially limited to direct intramural needle injections of cell suspensions under direct visualization in the operative setting. An alternative method of intra-arterial or intraventricular injection of cell suspensions into the bloodstream has been described that resulted in successful engraftation of cells within the myocardium. Robinson *et al.*, *Arterial Delivery of Genetically Labeled Skeletal Myoblasts to the*  
25 *Murine Heart: Long-term Survival and Phenotypic Modification of Implanted Myoblasts*, Cell Transplantation vol. 5, pages 77-91 (1996). Microsphere technology, well-known to practitioners in the art, has been described for the delivery of angiogenic factors to the heart. Arras *et al.*, *The Delivery of Angiogenic Factors to the Heart by Microsphere Therapy*, Nature Biotechnology vol. 16, pages 159-162 (1998). It is a  
30 realization of the present invention that the delivery of a combination of therapeutic agents, including those agents adapted for stimulating angiogenesis and those agents containing cells adapted for implantation in the myocardium, can be provided by a system of pellets that are introduced into the myocardium. The teachings of the abovementioned articles are incorporated herein by reference.

35

5           The pellets described above can be adapted for delivery of a combination of  
therapeutic agents, including those agents capable of stimulating angiogenesis and those  
agents containing cells adapted for implantation in the myocardium. In one embodiment,  
the pellet can be formed of a biocompatible material with a plurality of surfaces  
10           contacting the tissues of the myocardium and thereby promoting localized angiogenesis.  
A biocompatible material as described herein is one that does not incite systemic toxic  
reactions. In this embodiment, the pellet contains an inner reservoir that delivers into the  
myocardium cells adapted for implantation. In yet another embodiment, the pellet can be  
formed to contain at least one inner reservoir which contains at least one therapeutic  
15           agent. In this embodiment, the reservoir is permeable to at least one of the therapeutic  
agents it contains. For example, cells adapted for implantation in the myocardium can be  
contained in this reservoir, to be delivered into the surrounding tissues by permeating the  
reservoir wall. Alternatively, the pellet or the reservoir within it may be made of a  
bioresorbable material, holding the cells inside until it has undergone some degree of  
resorption. The reservoir can contain molecular ligands that have affinity for surface  
20           markers of circulating myocyte precursor cells, so these cells become enclosed within the  
reservoir until their release.

          In another embodiment, the delivery system includes a pellet made of a  
biocompatible material that contains at least one reservoir permeable to at least one of the  
25           therapeutic agents it contains. Within this pellet are at least two therapeutic agents, one  
agent capable of promoting angiogenesis and another agent containing cells adapted for  
implantation in the myocardium. In one embodiment, the pellet contains at least two  
reservoirs, with one therapeutic agent disposed in each. These reservoirs can have  
different permeability characteristics, so there is differential release of the two agents. In  
30           one embodiment, the pellet includes a drug releasing compound capable of releasing at  
least one therapeutic agent, while the other agent is retained within a reservoir contained  
within the pellet. The pellet or any reservoir within it can be made of a bioresorbable  
material. The reservoir can contain molecular ligands that have affinity for surface  
35           markers of circulating myocyte precursor cells, so these cells become enclosed within the  
reservoir until their release.

5           Techniques and materials for forming pellets capable of acting as drug delivery implants are well known in the art. In one practice, a solid pellet is formed from a biodegradable polymer that has been doped or "seeded" with the desired therapeutic agent. Typically, the polymer is a synthetic polymer, such as poly(lactic acid) or polyorthoesters, and is formed by solvent  
10 evaporation, spray drying, or phase separation. Such a pellet 70 is depicted in FIG. 4A. The polymer is capable of breaking down over time, allowing the drug to be released into the adjacent tissue. To aid in visualizing the implant by fluoroscopy or x-ray, a sphere of a precious metal, such as gold or platinum, can be covered with the drug-filled polymer 72 in a thickness that provides the desired volume, dosage and/or time release profile.  
15 Other acceptable drug delivery implants include the "container" implant which is filled with a liquid drug. A wall of the container is at least partially made of a biodegradable polymer that permits passage of drug molecules at a certain rate. This design is common for injectable microspheres. One advantage is that it can work for drugs that are not amenable to doping in polymers because of heat processes or other incompatibilities. A  
20 radio-opaque metal core could be incorporated into this "container" type pellet to facilitate viewing.

          Additionally, pellets delivered into or against the tissue wall can be coated with or include adhesive materials that adhere to tissue. Further, coatings can be provided that  
25 facilitate the absorption of the pellet into the tissue wall. Such coatings can include fumaric acid, sebacic acid and other similar materials.

          FIG. 4B depicts in more detail a pellet 76 suitable for delivery by the delivery chamber 50 depicted in FIGS. 3A and 3B. The pellet 76 is a hollow conical body that  
30 provides a pointed end that facilitates delivery of the pellet 76 into a tissue wall. Optionally, the pellet 76 can carry a radio opaque marker (not shown) and, in one embodiment, the radio opaque marker comprises grains of a noble metal which are incorporated into the material of which the pellet 76 is formed.

5 It will be apparent to one of ordinary skill in the art that other drug delivery implants can be employed with the systems described herein, including disc shaped pills or cylindrical implants that incorporate a solid, drug-filled polymer core with the container-type biodegradable polymer wall. One such implant is described in U.S. patent 5,629,008, which is incorporated herein in its entirety by reference.

10 FIGS. 5 and 6 depict more explicitly one method according to the invention for implanting a therapeutic agent into a tissue wall. The depicted method is a cardiovascular treatment for restenosis that can occur in a coronary artery. The method includes the steps of employing an elongate flexible surgical instrument (e.g., a catheter) having a  
15 distal end that carries a delivery chamber 14. The distal end is inserted into a vascular system of a patient, such as by insertion via a femoral artery or vein. The delivery chamber 14 is guided through the patient's vascular system until the delivery chamber 14 is disposed within the heart, such as within the left ventricle. Once within the heart, the delivery chamber is employed to implant a therapeutic agent into the tissue of the heart.

20 In a first step the physician can determine the therapeutic agent, or agents, to be implanted and the depot for the selected agents. The depot may be selected by considering, *inter alia*, the desired time of drug residence within the tissue and the desired dosage to be eluted during the course of the residence. Optionally, the pellets can  
25 carry a plurality of therapeutic agents, either by solidifying a plurality of agents within the polymer coating of each pellet, or by providing pellets carrying different therapeutic agents. This latter practice allows the physician to load both active therapeutic agents and agents capable of activating therapeutic agents upon contact, or capable of degrading the polymer wall of an implanted pellet. This can allow for greater time delay before  
30 activation of an agent, and for greater selection in the delivery vehicle and the agents and drugs being delivered. Once the agents are selected, the physician can select the delivery chamber to use and can pre-load the delivery chamber with a plurality of pellets, each of which can be a minisphere, a helical, conical pellet, a cylindrical container, or other device capable of being implanted into the myocardium. The physician can preload the delivery  
35 chamber 14 with the set of pellets that have been selected to deliver the proper depot of

5 therapeutic agent to the tissue around an artery that is suffering from, or may suffer from, restenosis. Alternatively, pellets containing a desired therapeutic agent can be preloaded into the delivery system, which is provided to the physician as a sterile, disposable item.

10 Before delivering the preloaded delivery chamber 14 into the heart, the treating physician optionally performs a preliminary step of positioning a radio-opaque marker at the site of restenosis. This allows the treating physician to view the marker during delivery of the pellets. The marker can be a stent, or any viewable marker that will remain present at the site of the localized disease during the implanting of the drug delivery pellets.

15 In one practice, the marker can be the radio-opaque marker of a balloon being employed during a PTCA procedure. Specifically, as restenosis may arise from the site of the angioplasty, one practice of the invention performs the drug delivery at the same time as the angioplasty. In this procedure, the treating physician leaves the PTCA catheter in place, while the delivery implant system is guided to the target area. A radiopaque marker in the balloon gives fluoroscopic guidance during the implant procedure.

20 At this time, the physician can guide the implant system along the appropriate delivery route until the catheter enters the interior of the patient's heart. The delivery chamber can approach target areas from within any chamber of the heart. Notably, the practices described herein allow that even septal arteries can be treated for cardiac conditions or to stimulate angiogenesis. In FIG. 5, the delivery chamber is shown as approaching the target area from the interior of the heart, and positioning the delivery chamber against the endocardial tissue over the myocardium. Upon positioning the delivery chamber adjacent the interior tissue wall of the heart, the physician drives the delivery chamber into the tissue and to the targeted area. The physician actuates the control mechanism and ejects a pellet from the delivery chamber, implanting the pellet within the targeted area of the myocardium.

5 It is a realization of the present invention that the practices described herein are often suitable for arteries normally considered epicardial, with little surrounding myocardial tissue or subepicardial fat in which to implant the drug delivery pellets. Specifically, researchers have noted that tunneled epicardial coronary arteries may represent a normal variant being recognized in up to 86% of vessels. Waller, *Anatomy, 10 Histology, and Pathology of the Major Epicardial Coronary Arteries Relevant to Echocardiographic Imaging Techniques*, Journal of American Society of Echocardiographic Imaging, vol. 2 (1989).

15 FIG. 6 illustrates a further realization of the present invention. FIG. 6 shows that it is desirable to implant the pellets as close as possible to the artery being treated, and that providing an array of implanted pellets about the periphery of the artery may provide sufficient localized elution of therapeutic agent to prevent restenosis. In one practice, the pellets are implanted through a single point of entry through the myocardium. The physician manipulates the distal tip of the catheter to dispose the port of the delivery 20 chamber at the depicted locations. At each location, a pellet is ejected from the delivery chamber and implanted into the myocardium.

25 FIG. 7 depicts a further alternative embodiment of the invention. The depicted system 80 includes a short catheter 82 that carries a delivery chamber 84 at its distal end and that connects at its proximal end to a pistol grip control mechanism 88.

30 The system 80 is adapted for use during an endoscopic procedure and to that end the depicted catheter 84 is a short catheter adapted to slide within a endoscopic port that has been placed through the chest and positioned abutting the pericardium. The delivery chamber 84 can be a delivery chamber as discussed above and can be dimensionally adapted to penetrate and extend through the pericardial sac. The delivery chamber can penetrate into the myocardium and thereby allow the physician to implant pellets into the myocardium. Optionally, the catheter 82 can be a steerable catheter which allows the physician to bend the distal tip of the catheter 82 to place the delivery chamber 84 where 35 needed. Alternatively, the catheter can include a deflectable tip, as is known in the art,



5 which the physician can direct to the targeted area. Other modifications to the system 80, including providing the catheter with a fiber optic viewing device to allow the physician to view the interior of the pericardial sac, can be made without departing from the scope of the invention.

10 The depicted pistol grip 88 provides the physician with a manual actuator that allows the physician to control the implanting of pellets within the myocardium. The pistol grip 88 can be a molded plastic assembly of the type well known in the art for actuating a mechanical assembly, such as the plunger assembly of the delivery chamber 14 described above.

15 In a further practice, the techniques of the invention can be employed during an open chest procedure. Specifically, the surgeon performing the open chest operation can employ a delivery device that includes a delivery chamber as described above to implant pellets into the myocardium. Additionally, in this practice, the physician can employ a hypodermic needle to inject a solution containing microspheres of a therapeutic agent.  
20 Other practices of the invention can be practiced without departing from the scope thereof.

25 Moreover, the systems and methods for implanting depots of therapeutic agents can be applied to conditions other than those relating to cardiac failure. For example, the systems described herein can be applied to the treatment of muscle tissue afflicted by insufficient circulation. In one practice, the systems described herein are employed to deliver a human angiogenic growth factor, such as VEGF, which is understood to stimulate the growth of blood vessels. Thus, the systems described herein can promote  
30 the survival of muscle tissue that is moribund as a result of poor circulation due to failing or occluding blood vessels.

35 Those skilled in the art will know or be able to ascertain using no more than routine experimentation, many equivalents to the embodiments and practices described herein. For example, the devices described herein can be used in cooperation with

5 drilling elements or laser devices capable of forming an opening in a tissue wall, such as  
the myocardium. The delivery chamber can be inserted into the preformed openings for  
delivering a therapeutic agent therein. Further, pellets according to the invention can  
include threaded exterior surfaces that facilitate implanting the pellet within a tissue wall.  
Accordingly, it will be understood that the invention is not to be limited to the  
10 embodiments disclosed herein, but is to be understood from the following claims, which  
are to be interpreted as broadly as allowed under the law.

5

We claim:

1. A kit for implanting an agent into a tissue wall, comprising
- (a) an elongate flexible body having a proximal end and a distal end, a delivery chamber coupled to the distal end of the body and having a space for carrying the agent, and a port for releasing the therapeutic agent therefrom,
- an actuator coupled to the delivery chamber and capable of driving the agent through the port, and.
- (b) a pellet adapted to be received within said delivery chamber and being formed from a material capable of promoting localized angiogenesis, and having a reservoir for carrying cells for implantation in said myocardial tissue.
2. An apparatus for delivering at least two therapeutic agents to the myocardium comprising:
- a body formed of a biocompatible material containing at least one reservoir permeable to at least one therapeutic agent,
- wherein the first therapeutic agent contains at least one agent capable of promoting angiogenesis, and
- wherein the second therapeutic agent contains cells adapted for implantation in said myocardial tissue.
3. An apparatus according to claim 2 wherein at least two therapeutic agents are disposed in separate reservoirs, each reservoir formed of a biocompatible material permeable to the therapeutic agent disposed within it.
4. An apparatus according to claim 2 wherein at least two therapeutic agents are disposed within a single reservoir.
5. An apparatus according to claim 2 wherein said biocompatible material comprises a drug releasing compound capable of releasing at least one therapeutic agent.

10

15

20

25

30

35

5 6. An apparatus according to claim 5 wherein said drug releasing compound is capable of releasing at least one therapeutic agent capable of promoting angiogenesis.

7. An apparatus according to claim 2 wherein said biocompatible material is a bioresorbable material.

10 8. An apparatus according to claim 2 wherein said body includes at least a first and a second member, each having a respective one of said first and said second therapeutic agents.

15 9. An apparatus according to claim 2 wherein said reservoir contains molecular ligands, said ligands possessing specific affinity for cell surface markers expressed on circulating myocyte precursor cells, whereby said myocyte precursor cells become affixed within said reservoir.

20 10. An apparatus for delivering at least one therapeutic agent to the myocardium comprising  
a pellet formed from a biocompatible material with a plurality of surfaces contacting the tissues of the myocardium to promote localized angiogenesis, and  
a reservoir disposed within said pellet adapted for delivering cells capable of  
5 implantation in said myocardial tissue.

11. An apparatus according to claim 10 wherein said cells adapted for implantation include skeletal myoblast-derived cells.

) 12. An apparatus according to claim 10 wherein said cells adapted for implantation include cardiomyocytes.

13. An apparatus according to claim 10 wherein said cells adapted for implantation include precursors to cardiomyocytes.

5 14. An apparatus according to claim 10 wherein said cells adapted for implantation include genetically modified fibroblasts.

10 15. An apparatus according to claim 10 wherein said cells adapted for implantation include precursors to fibroblasts.

16. An apparatus according to claim 10 wherein said cells adapted for implantation include bone marrow stromal cells.

15 17. An apparatus according to claim 10 wherein said biocompatible material comprises a drug releasing compound capable of releasing at least one therapeutic agent.

18. An apparatus according to claim 10 wherein said drug releasing compound is capable of releasing at least one therapeutic agent capable of promoting angiogenesis.

20 19. An apparatus according to claim 10 wherein said biocompatible material is a bioresorbable material.

25 20. An apparatus according to claim 1 wherein the inner reservoir contains a molecular ligand, said ligand possessing specific affinity for at least one cell surface marker expressed on a circulating myocyte precursor cell, and said ligand capable of affixing said myocyte precursor cell within said reservoir

0 21. A method for improving contractile function of myocardial tissue that has suffered ischemic damage, comprising the steps of  
identifying a damaged portion of myocardial tissue,  
providing a catheter having a distal end adapted for delivering therapeutic agents into myocardial tissue,  
introducing said catheter into an anatomic structure,  
guiding said catheter through the anatomic structure to reach a surface of the  
5 heart,

5 disposing said distal end against the surface of the heart, and  
sequentially delivering at least two therapeutic agents through the surface of the  
heart to the damaged myocardial tissue,  
wherein the first therapeutic agent contains at least one angiogenic factor,  
and wherein the second therapeutic agent contains implantable cells  
10 adapted for restoration of contractile function.

22. A method for improving contractile function of myocardial tissue that has suffered  
ischemic damage, comprising the steps of

15 identifying a damaged portion of myocardial tissue,  
accessing said damaged portion of myocardial tissue, and  
delivering at least two therapeutic agents to the damaged portion of myocardial  
tissue,

wherein the first therapeutic agent contains at least one agent capable of  
promoting angiogenesis,

20 wherein the second therapeutic agent contains cells adapted for  
implantation in said myocardial tissue, and  
whereby the first therapeutic agent evokes a local angiogenic response in  
the damaged myocardial tissue and the second therapeutic agent  
introduces cells adapted for implantation in said myocardial tissue,  
25 said cells capable of regenerating contractile muscle tissue to  
achieve improved contractile function.

23. A method according to claim 22, wherein identifying a damaged portion of tissue  
includes identifying an infarcted portion of myocardial tissue.

30 24. A method according to claim 22, wherein delivering a therapeutic agent includes  
delivering a therapeutic agent being capable of mitigating tissue-level preconditions for  
reperfusion injury.

- 5           25. A method according to claim 22, including the steps of  
              releasing at least one angiogenic factor from the first therapeutic agent, and  
              releasing the cells adapted for implantation from the second therapeutic agent  
              after the release of the angiogenic factor.
- 10           26. A method according to claim 22, wherein at least one therapeutic agent includes a  
              time release delivery vehicle.
27. A method according to claim 22, wherein said cells adapted for implantation in the  
              myocardial tissue include skeletal myoblast-derived cells.
- 15           28. A method according to claim 22, wherein said cells adapted for implantation in the  
              myocardial tissue include cardiomyocytes.
29. A method according to claim 22, wherein said cells adapted for implantation in the  
20           myocardial tissue include precursors to cardiomyocytes.
30. A method according to claim 22, wherein said cells adapted for implantation in the  
              myocardial tissue include genetically modified fibroblasts.
- 25           31. A method according to claim 22, wherein said cells adapted for implantation in the  
              myocardial tissue include bone marrow stromal cells.

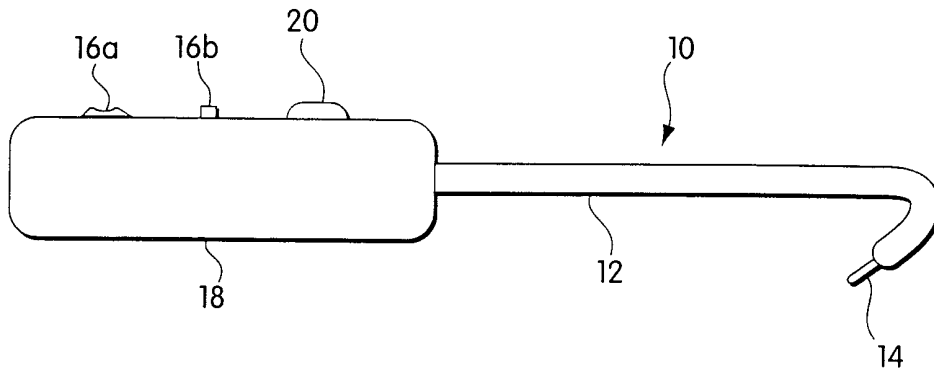

Fig. 1

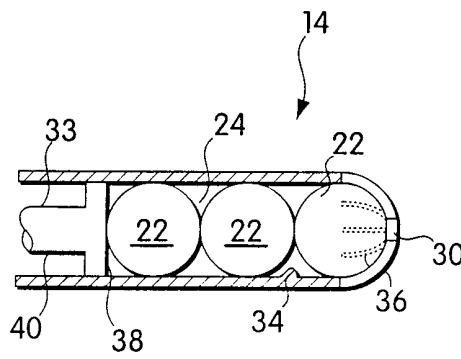

Fig. 2A

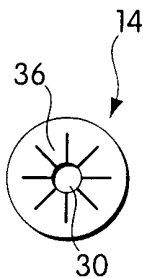

Fig. 2B



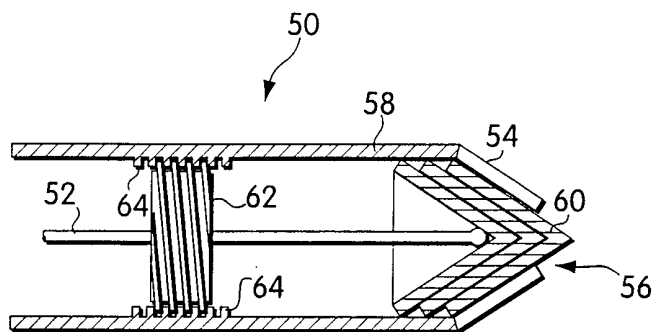

Fig. 3A

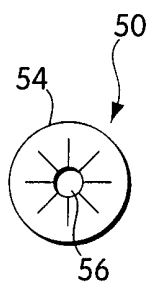

Fig. 3B

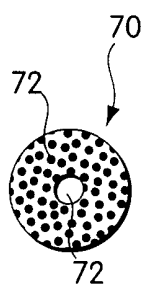

Fig. 4A

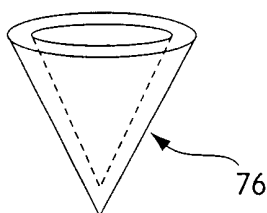

Fig. 4B

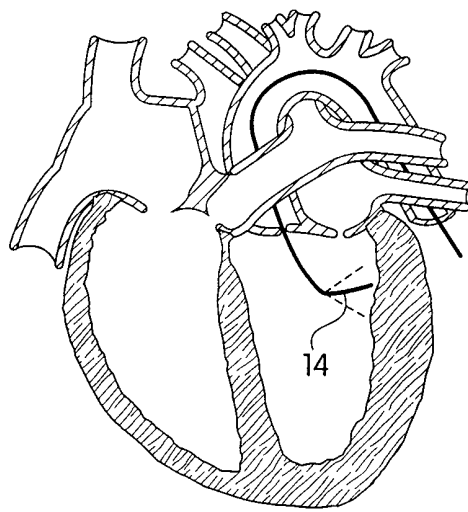

Fig. 5

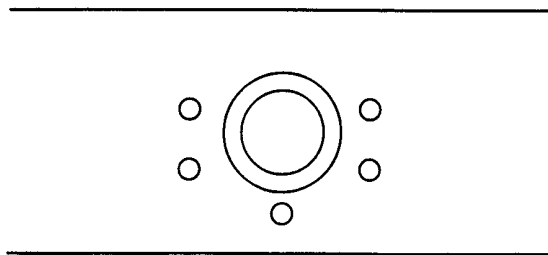

Fig. 6

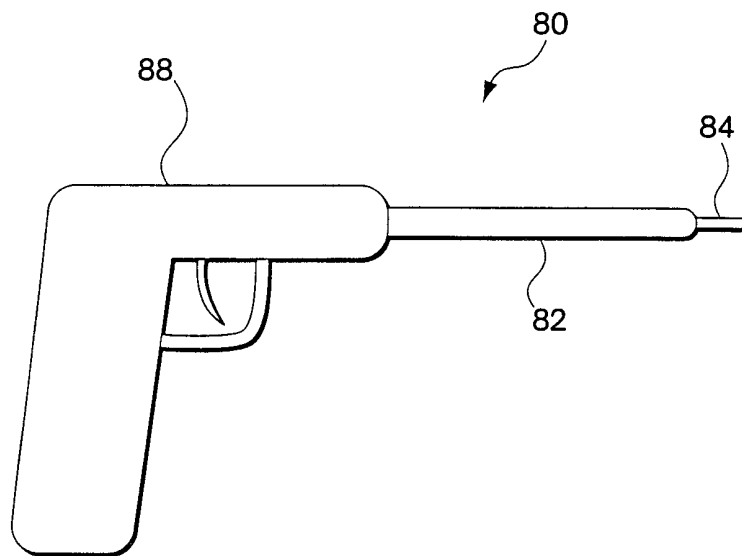

Fig. 7

# INTERNATIONAL SEARCH REPORT

International Application No

PCT/US 99/22392

**A. CLASSIFICATION OF SUBJECT MATTER**  
 IPC 7 A61M31/00 A61K48/00

According to International Patent Classification (IPC) or to both national classification and IPC

**B. FIELDS SEARCHED**

Minimum documentation searched (classification system followed by classification symbols)  
 IPC 7 A61N A61M A61K A61B

Documentation searched other than minimum documentation to the extent that such documents are included in the fields searched

Electronic data base consulted during the international search (name of data base and, where practical, search terms used)

**C. DOCUMENTS CONSIDERED TO BE RELEVANT**

Category *	Citation of document, with indication, where appropriate, of the relevant passages	Relevant to claim No.
X	EP 0 853 921 A (ECLIPSE SURGICAL TECH) 22 July 1998 (1998-07-22) page 2, line 1 - line 13 page 3, line 9 - line 43 page 5, line 38 -page 6, line 39 page 11, line 1 -page 20, line 4 figures	1,2,5,6, 10,17,18
X	US 5 180 366 A (WOODS W T) 19 January 1993 (1993-01-19) the whole document	1
Y	WO 95 33511 A (BARD INC C R) 14 December 1995 (1995-12-14) the whole document	2-8, 10-15, 17-19
	-/--	

Further documents are listed in the continuation of box C.

Patent family members are listed in annex.

\* Special categories of cited documents :

- "A" document defining the general state of the art which is not considered to be of particular relevance
- "E" earlier document but published on or after the international filing date
- "L" document which may throw doubts on priority claim(s) or which is cited to establish the publication date of another citation or other special reason (as specified)
- "O" document referring to an oral disclosure, use, exhibition or other means
- "P" document published prior to the international filing date but later than the priority date claimed

- "T" later document published after the international filing date or priority date and not in conflict with the application but cited to understand the principle or theory underlying the invention
- "X" document of particular relevance; the claimed invention cannot be considered novel or cannot be considered to involve an inventive step when the document is taken alone
- "Y" document of particular relevance; the claimed invention cannot be considered to involve an inventive step when the document is combined with one or more other such documents, such combination being obvious to a person skilled in the art.
- "&" document member of the same patent family

Date of the actual completion of the international search

20 January 2000

Date of mailing of the international search report

28/01/2000

Name and mailing address of the ISA

European Patent Office, P.B. 5818 Patentlaan 2  
 NL - 2280 HV Rijswijk  
 Tel. (+31-70) 340-2040, Tx. 31 651 epo nl,  
 Fax: (+31-70) 340-3016

Authorized officer

Ferrigno, A

INTERNATIONAL SEARCH REPORT

International Application No

PCT/US 99/22392

C.(Continuation) DOCUMENTS CONSIDERED TO BE RELEVANT

Category	Citation of document, with indication, where appropriate, of the relevant passages	Relevant to claim No.
Y	<p>WO 94 27612 A (BAYLOR COLLEGE MEDICINE) 8 December 1994 (1994-12-08)</p> <p>page 1, line 1 - line 10 page 8, line 15 -page 13, line 18 page 23, line 33 -page 25, line 2 page 34, line 1 -page 35, line 34</p>	<p>2-8, 10-15, 17-19</p>
A	<p>WO 97 45105 A (ANGIOTECH PHARMACEUTICALS INC ;UNIV BRITISH COLUMBIA (CA); HUNTER) 4 December 1997 (1997-12-04)</p> <p>page 1, line 16 - line 23 page 2, line 25 -page 6, line 6 page 13, line 9 -page 17, line 11 page 31, line 11 - line 22 page 34, line 6 -page 38, line 14</p>	<p>1-20</p>
A	<p>WO 96 20698 A (UNIV MICHIGAN ;LEVY ROBERT J (US); LABHASETWAR VINOD D (US); SONG) 11 July 1996 (1996-07-11)</p> <p>page 1, line 4 -page 2, line 20 page 5, line 8 -page 10, line 13 page 11, line 18 - line 20 page 56, line 13 -page 57, line 10 page 97, line 1 -page 104, line 10</p>	<p>1-20</p>

# INTERNATIONAL SEARCH REPORT

International application No.

PCT/US 99/ 22392

## Box I Observations where certain claims were found unsearchable (Continuation of item 1 of first sheet)

This International Search Report has not been established in respect of certain claims under Article 17(2)(a) for the following reasons:

1.  Claims Nos.: 21-31  
because they relate to subject matter not required to be searched by this Authority, namely:  
Rule 39.1(iv) PCT - Method for treatment of the human or animal body by therapy
2.  Claims Nos.:  
because they relate to parts of the International Application that do not comply with the prescribed requirements to such an extent that no meaningful International Search can be carried out, specifically:
3.  Claims Nos.:  
because they are dependent claims and are not drafted in accordance with the second and third sentences of Rule 6.4(a).

## Box II Observations where unity of invention is lacking (Continuation of item 2 of first sheet)

This International Searching Authority found multiple inventions in this International application, as follows:

1.  As all required additional search fees were timely paid by the applicant, this International Search Report covers all searchable claims.
2.  As all searchable claims could be searched without effort justifying an additional fee, this Authority did not invite payment of any additional fee.
3.  As only some of the required additional search fees were timely paid by the applicant, this International Search Report covers only those claims for which fees were paid, specifically claims Nos.:
4.  No required additional search fees were timely paid by the applicant. Consequently, this International Search Report is restricted to the invention first mentioned in the claims; it is covered by claims Nos.:

Remark on Protest

- The additional search fees were accompanied by the applicant's protest.
- No protest accompanied the payment of additional search fees.

# INTERNATIONAL SEARCH REPORT

Information on patent family members

International Application No  
PCT/US 99/22392

Patent document cited in search report	Publication date	Patent family member(s)	Publication date
EP 0853921    A	22-07-1998	US 5925012 A	20-07-1999
		AU 4934097 A	02-07-1998
		CA 2225521 A	27-06-1998
		JP 10192414 A	28-07-1998
US 5180366    A	19-01-1993	NONE	
WO 9533511    A	14-12-1995	US 5629008 A	13-05-1997
WO 9427612    A	08-12-1994	AU 7019494 A	20-12-1994
WO 9745105    A	04-12-1997	AU 2760497 A	05-01-1998
		CN 1219872 A	16-06-1999
		EP 0914102 A	12-05-1999
		NO 985463 A	21-01-1999
WO 9620698    A	11-07-1996	AU 4755696 A	24-07-1996
		CA 2207961 A	11-07-1996
		EP 0805678 A	12-11-1997
		JP 10511957 T	17-11-1998