

S. B. Rittenhouse

Hoisting-Jack.

N^o 72329

Patented Dec. 17, 1867.

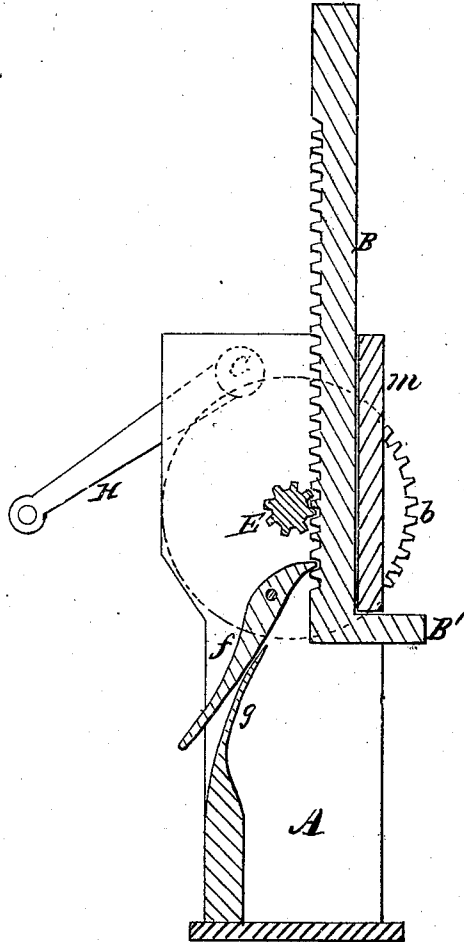
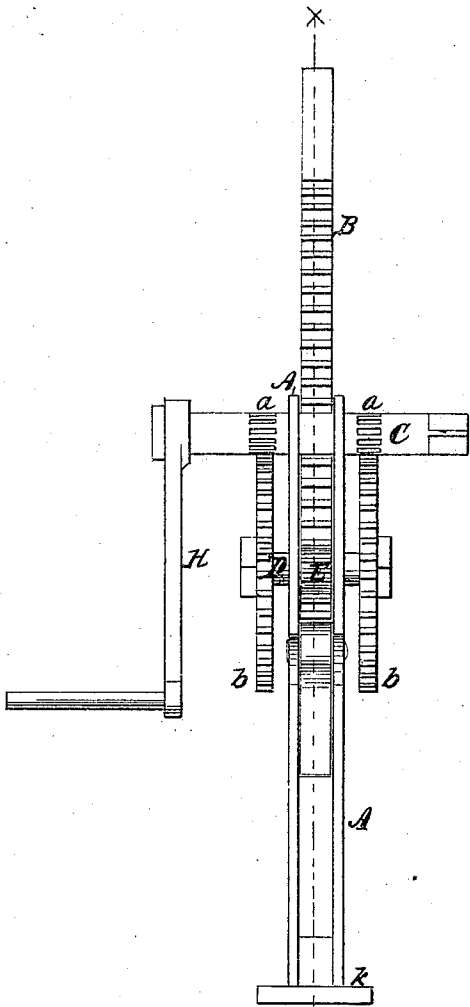

Witnesses.

H. A. Jackson
J. A. Service

Inventor.

S. B. Rittenhouse
Per Munn C
Attorney

United States Patent Office.

S. B. RITTENHOUSE, OF PLYMOUTH, INDIANA.

Letters Patent No. 72,329, dated December 17, 1867.

IMPROVEMENT IN HOISTING-JACK.

The Schedule referred to in these Letters Patent and making part of the same.

TO ALL WHOM IT MAY CONCERN:

Be it known that I, S. B. RITTENHOUSE, of Plymouth, in the county of Marshall, and State of Indiana, have invented a new and useful Improvement in Hoisting-Jacks; and I do hereby declare that the following is a full, clear, and exact description of the same.

The object of this invention is to provide a small and portable machine, through which a very great power may be obtained, for the purpose of hoisting heavy weights, or propelling heavy bodies, or exerting a great force in any direction, as propelling a ditching-machine or a plough for laying drain-tile; and the invention consists in operating upon a bar, (which shall have a rack or cogs upon its side,) by a lever or crank, through cog-wheels and pinions; and

To enable those skilled in the art to make and use my invention, I will proceed to describe its construction and operation, reference being had to the accompanying drawing, forming a part of this specification, and to the letters of reference marked thereon.

Figure 1 represents a view of the jack complete.

Figure 2 is a longitudinal section through the line *x x* of fig. 1.

A is the box which encloses the hoisting-bar, and which supports the shafts, to which the wheels and pinions are attached.

B is the hoisting-bar. This bar is square, or nearly so, and one side forms a rack, with cogs, extending from near its outer or upper end as far down on the bar as it is designed to have it move when operating with it. The lower end is turned out at B', and forms a stop against the box A, which is open on that side. The stop prevents the bar from moving too far out of the box, and is used for hoisting or drawing, when it is more convenient to apply the power of the jack from this point than from the other end of the bar.

C is a shaft, to which the power which operates the machine is applied. It has journals and bearings on the box A. It is formed so that levers or cranks may be attached to both ends. There are two pinions, *a a*, on this shaft, the pinions being formed in the shaft. The shaft stands at right angles with the hoisting-bar B.

D is another shaft, having bearings on it, and is supported by the box A. It has two spur-wheels, *b b*, one on each end, which work in the pinions on the shaft C. These wheels are placed on the shaft so that they work on the outside of the box, with collars, which prevent the shaft from having play endwise. The pinions or cogs on the shaft C are placed to fit the position of these wheels. On the middle of this shaft, D, inside the box, is the pinion, which works in the rack or cogs on the hoisting-bar B.

f is a pawl, which serves to hold the hoisting-bar up or to its place. The end of the pawl works against the cogs of the rack on the bar. It is kept in position by a spring, *g*. Both the spring and the pawl are attached to and work inside the box.

H is the lever or crank, attached to the shaft C. Upon the bottom end there is a broad plate, *k*, for the purpose of giving the jack a better bearing, and also to secure and hold together the side of the box.

It may be well to say here that the box A is mainly composed of two flat plates, which support the shafts, and between which the hoisting-bar works. These plates are made wider where the gearing-wheels are placed, in order that the wheels may be placed in a proper position.

There is a strong bar, *m*, placed back of the wheels, and back of the hoisting-bar, and against which the hoisting-bar bears. The sides of the box are firmly riveted to the bar.

The stop or dog B' allows the hoisting-bar to rise no higher than the bottom end of the bar *m*.

Having thus described my invention, what I claim as new, and desire to secure by Letters Patent, is—

1. The spring *g*, secured between the sides of the box A, and forming its front side, arranged in relation therewith, and with the pawl *f*, as herein shown and described.

2. The construction and arrangement of the box A, spring *g*, pawl *f*, projection B', upon hoisting-bar wheels *b*, cog-shaft C, shaft D, and pinion E, as herein set forth for the purpose specified.

S. B. RITTENHOUSE.

Witnesses:

C. H. REEVE,
ALEXANDER BLAND.