

[54] **CABINET UNIT EMPLOYING A FRAME WHICH CAN BE MOVED OUT OF A STATIONARY FRAME**

[72] Inventors: **John Andreini**, Irvington, N.J.; **Edwin Harley Borchard**; **Karl-Heinz Pohl**, both of Boulder, Colo.; **Joseph Anthony Puccio**, East Brunswick, N.J.

[73] Assignee: **Bell Telephone Laboratories, Incorporated**, Murray Hill, Berkeley Heights, N.J.

[22] Filed: **April 21, 1971**

[21] Appl. No.: **135,937**

[52] U.S. Cl.**312/320, 312/274, 312/250, 317/101 CB, 317/101 DH, 317/120**

[51] Int. Cl.**A47b 88/00**

[58] Field of Search.....**312/271, 274, 276, 320, 250; 317/101 CB, 101 DH, 99, 117, 120**

[56] **References Cited**

UNITED STATES PATENTS

622,335	4/1899	Eales et al.....	312/320 X
859,860	7/1907	Weir.....	312/320
1,938,470	12/1933	Teller et al.....	312/274 X
2,162,975	6/1939	Schmidt.....	312/274

2,588,046	3/1952	Ridgely.....	312/320 X
2,608,456	8/1952	Barth.....	312/274 X
3,009,753	11/1961	Gittins.....	312/274
3,016,276	1/1962	Morse.....	312/274
3,292,983	12/1966	Service.....	312/320 X

Primary Examiner—Lewis H. Myers
Assistant Examiner—Stanley J. Witkowski
Attorney—R. J. Guenther and Edwin B. Cave

[57] **ABSTRACT**

The cabinet unit comprises a movable frame that nests within a stationary frame comprising a head plate and a base plate extending forwardly from an upright frame. A door is pivotally secured to the forward end of the base plate so as to be movable between an upright and a prone position, and the door, the head plate, and the base plate all include means for guiding the displacement of the movable frame. In the upright position, the door serves to partially enclose the movable frame, and in the prone position, the door lies in the same plane as the base plate and serves as a platform onto which the movable frame is displaceable. Carriers for banks of electrical components are mounted on the movable frame, and with the movable frame positioned on the door, the entire perimeter of the frame is accessible for installation and service of the components supported by the carriers.

10 Claims, 5 Drawing Figures

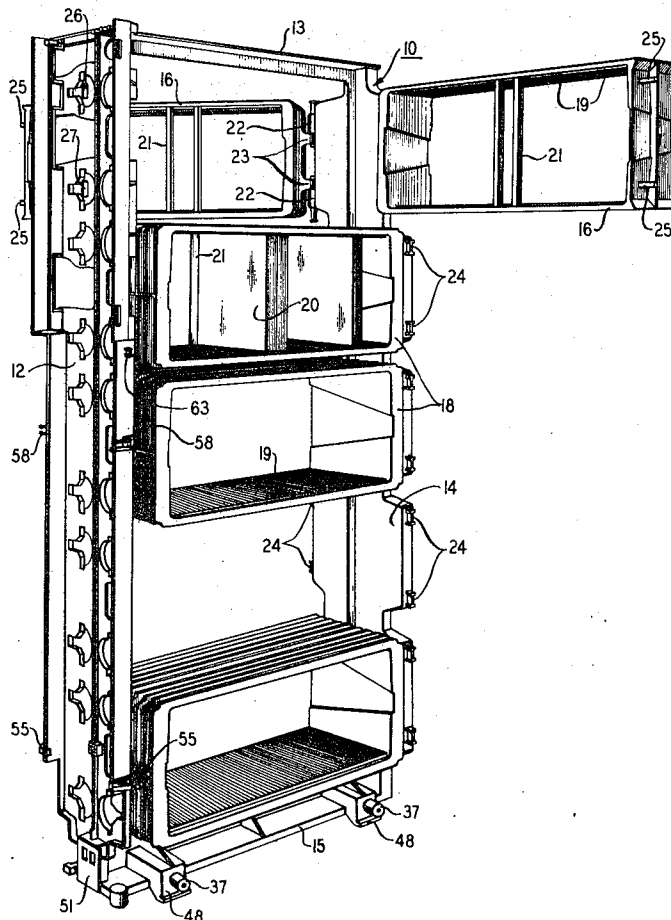
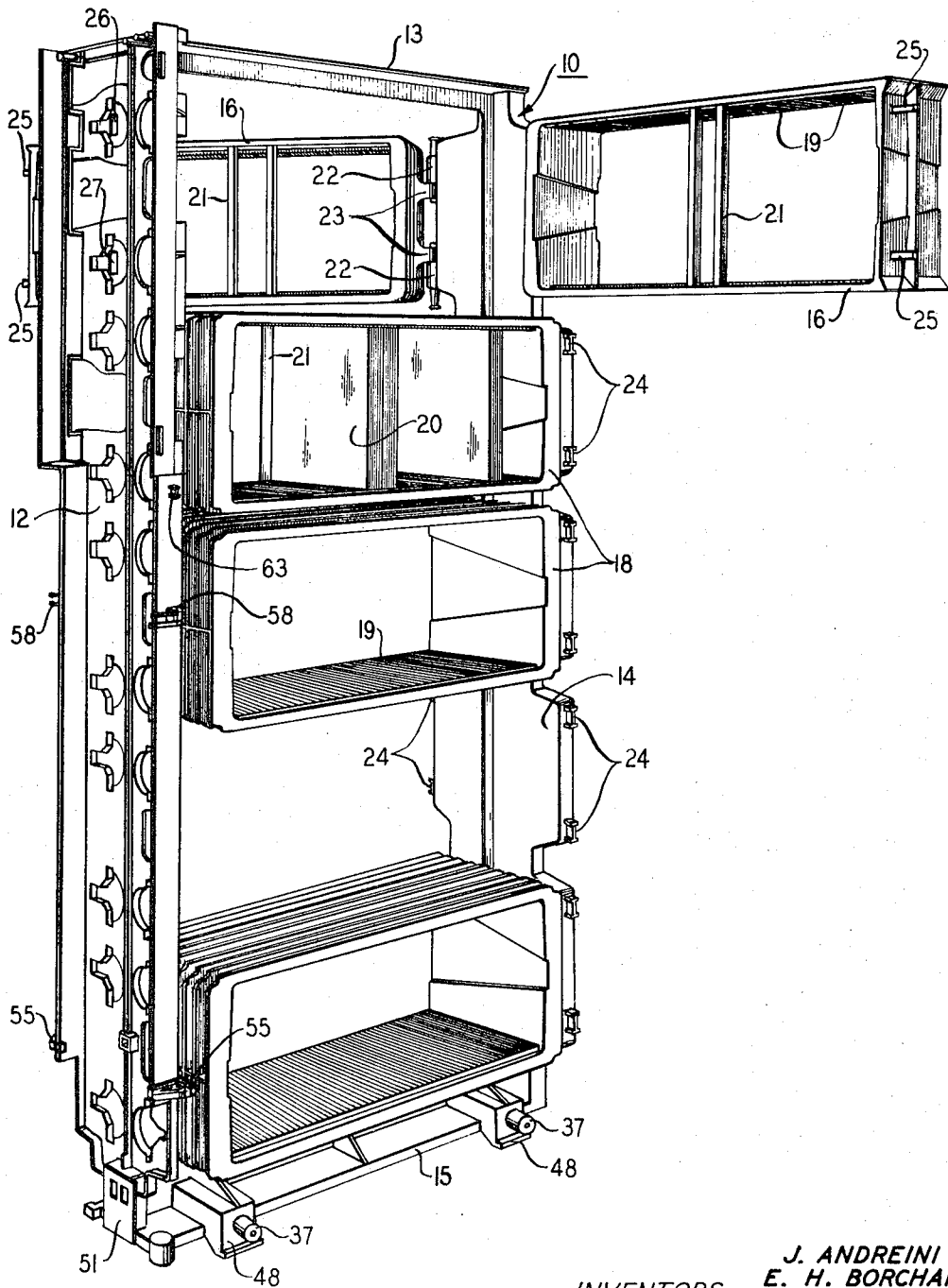

FIG. 1



J. ANDREINI
E. H. BORCHARD
K-H POHL
J. A. PUCCIO

INVENTORS

BY

Harry L. Newman

ATTORNEY

FIG. 2

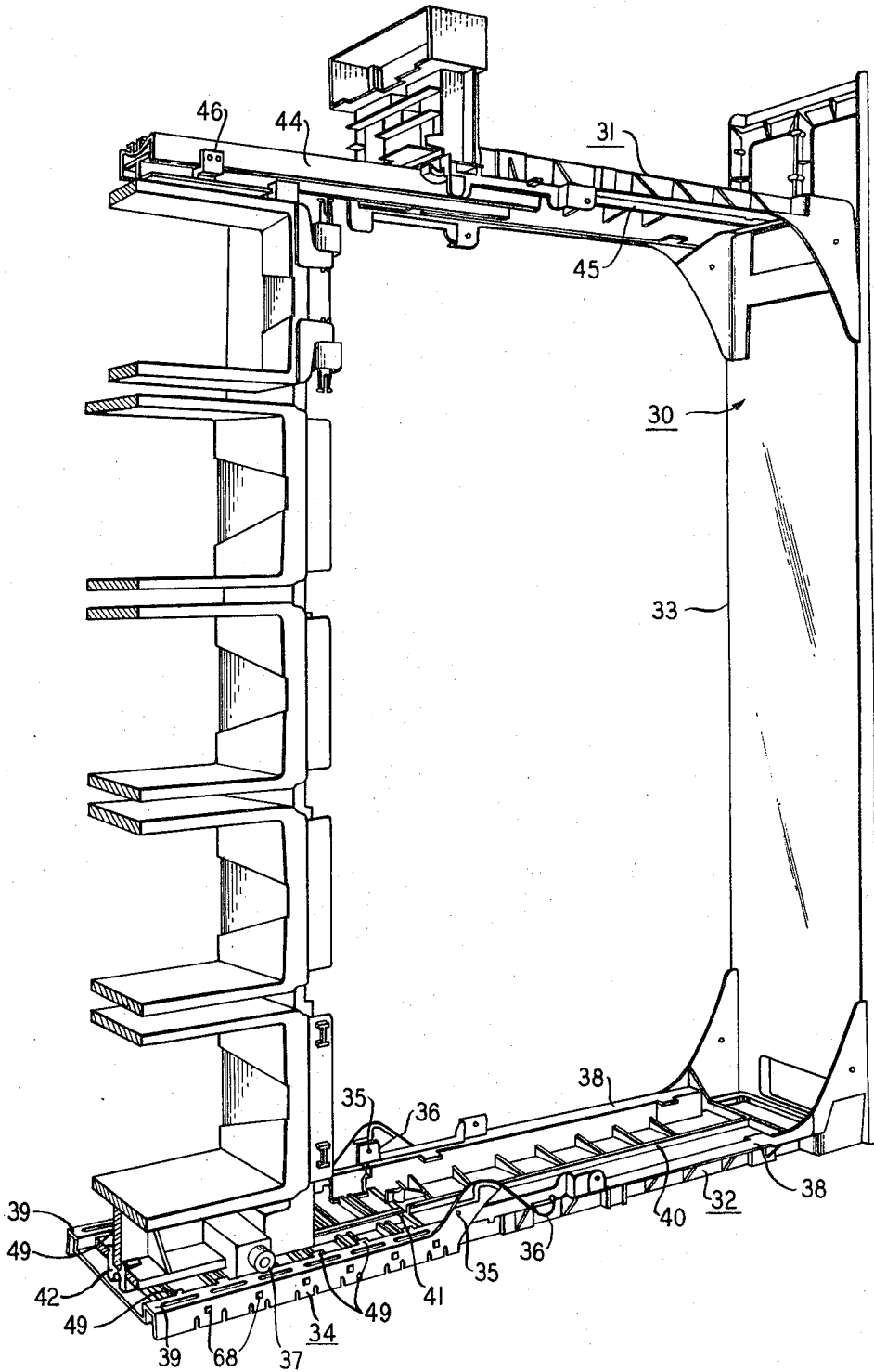

FIG. 3

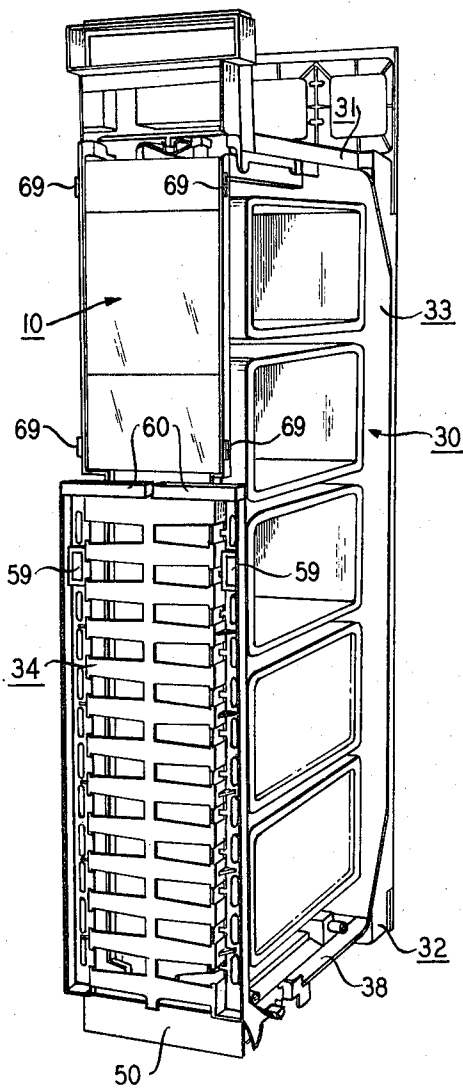

FIG. 5

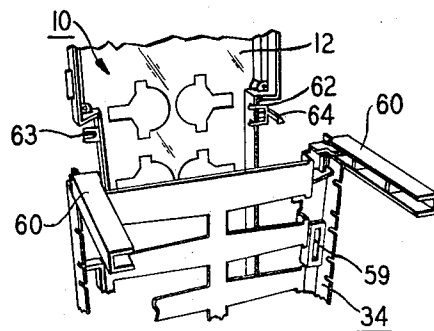
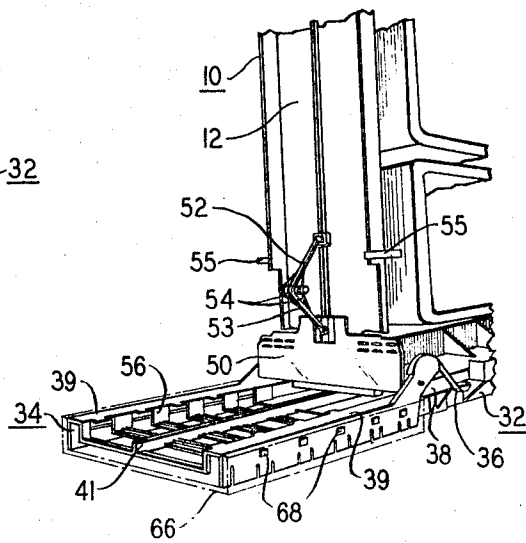

FIG. 4



CABINET UNIT EMPLOYING A FRAME WHICH CAN BE MOVED OUT OF A STATIONARY FRAME

Field of the Invention

This invention relates to apparatus for mounting electrical equipment, and within that field to a cabinet structure for accommodating banks of electrical and electronic components such as employed in telephone and computer networks.

Background of the Invention

In the design of cabinet structures to house electrical equipment, one of the most important considerations is the ease with which the equipment accommodated by the structure can be installed and serviced. Thus, the cabinet must be designed to permit access to both the equipment itself and to the terminals and wires that interconnect the equipment.

One common solution to this requirement is to mount each bank of components on a carrier that is either slidably displaceable like a drawer or pivotally attached like a door on the frame of the cabinet. During normal operation of the cabinet, the carrier is housed within the frame. However, when service or installation of components is required, the carrier is either slid out or rotated out from the frame. The carrier then extends out cantilever fashion from the frame to provide access to the components.

A problem with this arrangement has been that since the carrier supports most of the equipment and the frame is just a shell, the carrier when fully extended from the frame can actually tip the frame over. Bolting of the frame to the floor would of course solve this problem, but there are situations where this is objectionable or just not permitted. An alternative solution is to mount several carriers within a single frame and prevent more than one carrier from being simultaneously displaced from the frame. However, in the installation and service of the equipment it is often desirable to have access to more than one of the carriers and consequently this limitation makes installation and servicing more difficult and more time-consuming.

Summary of the Invention

The cabinet structure of the present invention does not suffer from this deficiency. The cabinet structure comprises a movable frame that nests within a stationary frame comprising a head plate and a base plate extending forwardly from an upright plate. A door is pivotally secured to the forward end of the base plate so as to be movable between an upright and a prone position, and the door, the head plate, and the base plate all include means for guiding the displacement of the movable frame. In the upright position, the door serves to partially enclose the movable frame, and in the prone position, the door lies in the same plane as the base plate and serves as a platform onto which the movable frame is displaceable. Carriers for banks of electrical components are mounted on the movable frame, and with the movable frame positioned on the door, the entire perimeter of the frame is accessible for installation and service of the components supported by the carriers.

In an illustrative embodiment, the movable frame is an open rectangular structure consisting of front, top,

back, and bottom plates. The carriers are smaller open rectangular structures that are either hinged to the back plate or are fixedly supported between the front and back plates of the movable frame. The hinged carriers are of a size to occupy approximately half the depth of the movable frame and two hinged carriers are always mounted back to back. When the hinged carriers are in their normal position, the components themselves are accessible from the sides of the movable frame and when one or both of the hinged carriers are swung out from the movable frame, the interconnections between components are accessible. The fixed carriers are of a size to occupy the full depth of the movable frame and the components mounted thereon are accessible from one side of the movable frame and the interconnections between components are accessible from the other side of the frame. With this arrangement the installation and servicing of the components is greatly facilitated.

Description of the Drawing

FIG. 1 is a perspective view of the movable frame of the cabinet of this invention;

FIG. 2 is a perspective view of the movable frame displaced from the stationary frame and positioned on the door of the cabinet;

FIG. 3 is a perspective view showing the movable frame nested within the stationary frame;

FIG. 4 is a perspective view showing the cooperating elements of the movable kickplate of the cabinet; and

FIG. 5 is a perspective view showing the legs of the door and the cooperating elements for assuring that the legs are extended before the door is lowered.

Detailed Description of the Invention

Referring to FIG. 1 of the drawing, the cabinet structure of this invention includes a rectangular movable frame 10 consisting of a front plate 12, a top plate 13, a back plate 14, and a bottom plate 15. The movable frame 10 may be cast as an integral unit or the plates 12 through 15 may be fabricated as individual members and joined together to form the frame.

Electrical components are supported on the movable frame 10 by means of either a hinged receptacle 16 or a fixed receptacle 18, both of which comprise an open-ended rectangular box-like structure. The top and bottom interior surfaces have parallel grooves 19 formed therein, and spaced parallel struts (not shown) extend rearwardly of the grooves. Each opposed pair of grooves 19 accommodates the lateral edges of a modular circuit package 20 and guides the package into engagement with a connector 21 that is located in alignment with the grooves by the associated struts. A detailed description of the receptacles is set forth in our copending application Ser. No. 4,912 filed on Jan. 22, 1970.

The hinged receptacles 16 have a depth that is approximately half the depth of the movable frame 10 so as to permit a pair of receptacles to be mounted back-to-back. Each pair is pivotally secured to the back plate 14 by means of hinge pintles 22 that are accommodated by barrels 23 formed on one end of the receptacles and that attach to bosses 24 extending from both sides of the back plate. The manner in which the barrels 23 are mounted on the pintles 22 and in which the

pintles are secured to the bosses 24 as described in detail in our copending application Ser. No. 67,903 filed on Aug. 28, 1970.

The end of each hinged receptacle 16 opposite to the barrels 23 includes a pair of protruding bars 25. The bars 25 respectively interact with a guide 26 and a latch 27 mounted on the front plate 12, to lock the hinged receptacle 16 in its closed position. A detailed description of the guide 26 and latch 27, the manner in which they are mounted on the front plate 12, and the manner in which they interact with the bars 25 is set forth in our copending application Ser. No. 67,902 filed Aug. 28, 1970.

The fixed receptacles 18 are of a size to occupy the full depth of the movable frame 10 and they are supported on the front and back plates 12 and 14 of the frame. Bolts (not shown) extend through openings in the plates and thread into tapped holes in the ends of the receptacles.

Referring also to FIG. 2, the movable frame 10 is housed within a stationary frame 30 including a head plate 31 and a base plate 32 extending forwardly from and at right angles to an upright plate 33. The stationary frame 30 also includes a door 34 that has one end thereof pivotally mounted by pins 35 to the forward end of the base plate 32. The door is thereby movable between a prone position shown in FIG. 2 and an upright position shown in FIG. 3. Movement between the two positions is facilitated by counterbalancing springs 36, the springs allowing the door 34 to be lowered gradually to its prone position and assisting in its being raised to its upright position.

The door 34 when in the prone position lies in the same plane as the base plate 32 and serves as a platform onto which the movable frame 10 is displaceable. The bottom plate 15 of the movable frame 10 has wheels 37 extending from both sides thereof that roll on aligned side ledges 38 and 39 respectively of the base plate 32 and door 34 to facilitate the displacement. In addition, the base plate 32 and the door 34 respectively have aligned center rails 40 and 41 that are embraced by self-lubricating plastic center guides 42 (only one of which is shown) secured to the bottom plate 15 to direct the displacement of the movable frame 10.

To prevent the movable frame 10 from being tipped over when it is positioned on the door 34, the head plate 31 of the stationary frame 30 is coupled to the top plate 13 of the movable frame 10 by a slidable guide 44. As shown in FIG. 2, the guide 44 includes a U-shaped center portion straddled by depending side portions. The center portion includes a U-shaped self-lubricating plastic insert (not shown) that embraces a center rail 45 of the head plate 31. The side portions, on the other hand, include opposed L-shaped self-lubricating plastic inserts (not shown) that embrace the sides of the top plate 13. When the movable frame 10 is rolled out onto the door 34, a pair of opposed stops 46 (only one of which is shown) fastened to the sides of the guide 44 are engaged by the back end of the top plate 13 to move the guide forward. Then when the movable frame 10 is returned to its normal position within the stationary frame 30, the front end of the plate 13 engages the stops 46 to move the guide 44 rearward.

As an added measure to prevent tipping of the movable frame, the bottom plate 15 of the movable frame 10 includes laterally extended flanges 48 underlying the wheels 37. The flanges 48 interact with a multiplicity of pairs of tabs 49 on the door 34 that extend inwardly toward one another from the ledges 39. The space between adjacent pairs of tabs 49 is less than the width of the flanges 48 so that at least the forward pair of flanges always extend beneath a pair of tabs as the movable frame 10 is being rolled onto or off of the door 34.

Referring now to FIGS. 1, 3, and 4, in order to permit the ledges 39 of the door 34 to move into close proximity with the ledges 38 of the base plate 32 so as to provide an essentially continuous surface on which the movable frame 10 rolls, the cabinet structure includes a kickplate 50 that moves upward when the door is lowered. The kickplate 50 is slidably mounted on a guide 51 secured to the front plate 12 of the movable frame 10, and a pair of pivotally joined arms 52 and 53 provide a linkage for displacing the kickplate.

The upper end of the arm 52 is pivotally secured to the front plate 12 while the lower end of the arm 53 is pivotally secured to the kickplate 50. In addition, a pair of coil springs 54 are disposed about the pivot at the juncture of the two arms 52 and 53, and the coil springs bias the arms so as to move the far ends of the arms toward each other. The center rail 41 of the door 34 is in alignment with the arms 52 and 53, and when the door is raised, the center rail engages the pivot at the juncture of the arms and moves it rearwardly, causing the kickplate 50 to move downward. Conversely when the door 34 is lowered, the springs 54 move the pivot at the juncture of the two arms 52 and 53 forward and raise the kickplate 50.

As the door 34 is raised to its upright position, it is centered by a pair of guides 55 secured to the sides of the front plate 12. Each guide 55 includes a cantilever arm that is engaged by an associated interior surface 56 of the door 34 and the two guides cooperate to prevent the door from being askew. The structure of the guides 55 and the manner in which they are secured to the front plate 12 are described in detail in our copending application Ser. No. 67,904 filed Aug. 28, 1970.

The door 34 is held in its upright position by a pair of latches 58 secured to the sides of the front plate 12 above the guides 55. Each latch 58 includes a pair of flexible cantilevered arms, the free ends of which include rounded nose portions facing in opposite directions from one another. The sides of the door 34 have tapered openings 59 therein, and as the door is moved into its upright position, the arms of the latches move into the openings and the nose portions grip the sides of the openings to hold the door closed. The door 34 is lowered by merely pulling it away from the latches 58, the flexible arms being deflected toward one another to permit the nose portions to pass through the openings 59. A more detailed description of the latches 58, the manner in which they are mounted on the front plate 12, and the manner in which they interact with the openings 59 in the door 34 is described in our above referred to application Ser. No. 67,903.

Turning now to FIG. 5, because in some situations it is desirable to place the cabinet on a pallet so as to have the cabinet raised off of the floor, the door 34 includes

a pair of legs 60. The legs 60 are pivotally mounted to the sides at the upper end of the door 34 so that when the door is in its upright position or when the door is in its prone position and the cabinet is not mounted on a pallet, the legs 60 can be folded back as shown in FIG. 3. The legs 60 then lie generally flush with the front of the door. When, however, the cabinet structure is positioned on a pallet and the door 34 is to be lowered to its open position, the legs 60 are extended. In that position they support the door 34 the same distance off of the floor as the height of the standard pallet.

Furthermore the door 34 is prevented from being inadvertently lowered without the legs 60 being extended by the use of latches 62 (only one of which is shown). These latches are secured to bosses (only one of which is shown) on the sides of the front plate 12 of the movable frame 10 and include a single flexible cantilevered arm 64 having a wedge-shaped catch at the free end thereof. Each catch interacts with a reversed wedge-shaped portion on the upper end of the door 34 so as to lock the door in its upright position.

In order to unlock the door 34 it is necessary to manually deflect the flexible arm 64 of each latch 62 so as to move the catch thereof out of the way of the associated portion on the door and then pull the door away from the latch. Access to the flexible arm 64 of the latch 62 is only obtained by extending the legs 60, and therefore the legs must be extended in order to unlock the door 34. When the cabinet structure is not positioned on a pallet, the latches 62 are omitted. A more detailed description of the latches 62, the manner in which they are mounted on the front plate 12, and the manner in which they interact with the cooperating portion on the door 34 are set forth in our above-referred to application Ser. No. 67,903.

The cabinet structure as illustrated is devoid of finishing or decorative panels, but such panels are easily attached. One decorative panel 66, shown in phantom in FIG. 4, attaches to the door 34, the sides of the door including wedge-shaped bosses 68 that snap into associated openings in the sides of the panel. A second decorative panel is held in place by ridges 69 on the sides of the front plate 12 of the movable frame 10. This second panel extends from just above the door 34 as shown in FIG. 3 to the top of the stationary frame 30 and is advantageously louvered to provide ventilation for the cabinet. The sides of the cabinet are enclosed by panels fastened to the head plate 31 and base plate 32 of the stationary frame 30. But where a multiplicity of cabinets are placed side by side, no side panels are used between the cabinets. Rather the head plates 31 and base plates 32 of adjacent cabinets are fastened together, and a side panel is attached to each end of the cabinets.

Although a specific embodiment of the invention has been shown and described, it will be understood that it is but illustrative and that various modifications may be made therein without departing from the scope and spirit of this invention as defined in the appended claims.

What is claimed is:

1. A cabinet for housing electrical equipment comprising:

a stationary frame including an upright plate and a head plate and base plate extending forwardly from the upright plate;

a movable frame to which the equipment to be housed within the cabinet is mounted, the movable frame being of a size to nest within the stationary frame; and

5 a door pivotally mounted to the forward end of the base plate of the stationary frame, the door being movable between an upright position where it extends parallel to the upright plate and serves to enclose the movable frame and a prone position wherein it lies in the same plane as the base plate and serves as a platform onto which the movable frame is displaceable when access to the equipment mounted on the movable frame is desired, the head plate, base plate and door including guide means for directing the displacement of the movable frame.

2. A cabinet structure as in claim 1 wherein the base plate and the door include side ledges that are aligned when the door is in its prone position, and the movable frame has wheels that roll on the side ledges to facilitate displacement and a kickplate that is displaced by the movement of the door to its prone position so as to permit the ledges of the door to move into close proximity with the ledges of the base plate.

3. A cabinet structure as in claim 1 wherein the guide means of the base plate and door comprise center rails, the center rail of the door being aligned with the center rail of the base plate when the door is in the prone position, and the movable frame includes guide means for embracing the center rails.

4. A cabinet structure as in claim 1 further including slidable means for coupling the guide means of the head plate of the stationary frame to the movable frame so as to prevent the movable frame from being tipped over when it is positioned on the door.

5. A cabinet structure as in claim 4 wherein the movable frame includes a top plate, the guide means of the head plate comprises a center rail, and the coupling means includes means for embracing and being displaceable along the center rail of the head plate and the sides of the top plate.

6. A cabinet structure as in claim 1 wherein each side of the base plate and the door includes a multiplicity of spaced tabs, the tabs of one side extending toward the tabs of the other side, and the movable frame includes a bottom plate having flanges that extend beneath the tabs, the space between adjacent tabs being less than the width of the flanges.

7. A cabinet structure as in claim 1 further including means for latching the door in its upright position and counterbalancing springs for facilitating the movement of the door between the upright and the prone positions.

8. A cabinet structure as in claim 1 wherein the door includes legs pivotally attached to the sides thereof, the legs when folded back being generally flush with the front of the door and the legs when extended supporting the door the same distance off of a floor as the height of the standard pallet.

9. A cabinet structure as in claim 8 further including an interlock to prevent the door from being lowered without first extending the legs.

10. A cabinet structure as in claim 1 further including a pair of hinged receptacles for modular circuit packages, the hinged receptacles being pivotally mounted back to back to the movable frame.

* * * * *