

(19) **DANMARK**



Patent- og
Varemærkestyrelsen

(10) **DK/EP 2552786 T3**

(12) **Oversættelse af
europæisk patentskrift**

-
- (51) Int.Cl.: **B 65 B 37/14 (2006.01)** **B 65 B 9/20 (2012.01)** **B 65 B 29/00 (2006.01)**
B 65 B 37/20 (2006.01)
- (45) Oversættelsen bekendtgjort den: **2015-12-21**
- (80) Dato for Den Europæiske Patentmyndigheds bekendtgørelse om meddelelse af patentet: **2015-10-14**
- (86) Europæisk ansøgning nr.: **11724756.9**
- (86) Europæisk indleveringsdag: **2011-03-28**
- (87) Den europæiske ansøgnings publiceringsdag: **2013-02-06**
- (86) International ansøgning nr.: **IB2011000986**
- (87) Internationalt publikationsnr.: **WO2011117732**
- (30) Prioritet: **2010-03-26 US 318212 P**
- (84) Designerede stater: **AL AT BE BG CH CY CZ DE DK EE ES FI FR GB GR HR HU IE IS IT LI LT LU LV MC MK MT NL NO PL PT RO RS SE SI SK SM TR**
- (73) Patenthaver: **Philip Morris Products S.A., Quai Jeanrenaud 3, 2000 Neuchâtel, Schweiz**
- (72) Opfinder: **WILLIAMS, Dwight, D., 1508 Swiftwood Drive, Powhatan, VA 23139, USA**
- (74) Fuldmægtig i Danmark: **Awapatent A/S, Rigensgade 11, 1316 København K, Danmark**
- (54) Benævnelse: **Apparat til pungspåfyldning af tobak, der har et højt fugtindhold**
- (56) Fremdragne publikationer:
EP-A1- 0 319 131
WO-A1-83/02434
WO-A2-2008/114122
DE-A1- 4 343 317

DESCRIPTION

Background

[0001] This disclosure relates to an apparatus for handling moist smokeless tobacco (MST) products. More particularly, the invention relates to an apparatus for precision dispensing of MST.

[0002] With conventional machines, methods for dosing and pouching MST include drying, pouching, rewetting and/or flavoring the MST, and then packaging the pouches for delivery to consumers. Typically, unless the MST is first dried, the MST cannot be accurately dosed or dispensed and then pouching on conventional pouching machines because the high moisture content of the tobacco causes clumping and non-uniform delivery of tobacco to the pouches. After drying, the MST is typically pouching and then rewetted. However, rewetting after pouching causes MST to clump, which causes non-uniform flavor delivery due to the higher density of the clumps within the pouch as compared to non-clumped portions of MST contained within the pouch. In addition, when the MST has been dried, the flavor and organoleptic characteristics may be undesirably changed when compared to loose, fibrous MST. Thus, it is desirable to pouch MST using an apparatus that can provide more uniform and accurate dosing of MST from a dosing cavity without the need for drying and/or rewetting steps.

[0003] There has existed a need for an apparatus for accurately dosing MST that obviates the need for drying MST prior to pouching, substantially reduces or prevents the need for rewetting MST after pouching, and provides substantially accurate dosing of oral tobacco pouch products.

[0004] EP 0 319 131 A1 discloses a machine for introducing a quantity of powder into a plurality of containers, comprising a powder transporting member having a plurality of downwardly open chambers, a container transporting member located below the powder transporting member, means for continuously rotating the powder transporting member and the container transporting member in unison about a substantially vertical axis, a reservoir for powder with which the said chambers communicate during part of the rotation of the powder transporting member, means for applying vacuum to the chambers to cause powder to be drawn therein, and means for discharging the powder from each chamber into a container carried by the container transporting member.

Summary

[0005] An apparatus for dispensing a charge of moist smokeless tobacco includes a rotary metering device comprising: a rotatable lower disk comprising a plurality of through openings; a rotatable metering disk comprising a plurality of through openings aligned with the plurality of through openings in the lower disk so as to define a plurality of cavities; pins mounted in the through openings of the lower disk and extending into the through openings of the metering disk, said pins having an upper screen defining bottoms of the plurality of cavities within the metering disk; a vacuum source for supplying a vacuum to the cavities during loading of the cavities; a reservoir above the metering disk for supplying MST to the cavities during loading of the cavities; and an air discharge mechanism for applying a blast of compressed air to each of the cavities when at a discharge station to eject a charge of MST therefrom.

[0006] In a preferred embodiment, the rotary metering device includes a lower disk which rotates in a horizontal plane, a metering disk which rotates in a horizontal plane and a vacuum housing located around the periphery of the lower disk and applying a vacuum to the cavities during loading of the cavities but not applying vacuum to the cavities when at the discharge station. Preferably, the pins are vertically movable within the metering disk to raise and lower the screen so as to increase or decrease a fill volume of the plurality of cavities. Moreover, preferably the rotary metering device includes a bowl surrounding the metering disk and adapted to hold a quantity of MST to be loaded into the cavities

[0007] Preferably, the vacuum housing is in communication with the plurality of cavities so as to substantially completely fill the cavities with MST during loading. In the preferred embodiment, the vacuum housing applies vacuum pressure in the cavities in an amount less than about 3.4 kPa (about 2.5 cm (about 1 inch) mercury), preferably about 0.4 kPa (about 0.3 cm (about 1/8 inch) mercury) to about 2.5 kPa (about 1.9 cm (about 3/4 inch) mercury), more preferably at or about 1.7 kPa (at or about 1.3 cm (about 1/2 inch) mercury). Preferably, the vacuum housing is connected to a frame and is stationary during rotation of the lower disk and metering disk. In the preferred embodiment, the rotary metering device includes two vacuum housings separated by at least two gaps which provide two applications of vacuum pressure to the cavities during rotation of the metering disk.

[0008] In the preferred embodiment, the apparatus also includes a hopper for containing moist smokeless tobacco prior to

delivery to the bowl of the rotary metering device and a tobacco feed drive system for conveying moist smokeless tobacco from the hopper to the rotary metering device. In the preferred embodiment, when one of the cavities is at the discharge station, a charge of MST in the cavity is discharged from the cavity via a discharge opening, which leads to a feed tube. Preferably, the feed tube communicates with the cavity for delivering a charge of loose moist smokeless tobacco from the rotary metering device to a pouching apparatus.

[0009] Also preferably, the discharge opening comprises a stationary funnel adjacent the upper surface of the metering disk. The outer surface of the funnel aids in skimming excess MST off the top of each cavity as the metering disk rotates thereunder. When the metering disk rotates such that the funnel is positioned over one of the cavities, the funnel directs the MST to the feed tube via an air blast. A blast of air from an air discharge mechanism, which is in fluid communication with the cavity at the discharge station effects discharge of MST from the cavity and into the feed tube. Also preferably, the feed tube comprises at least one pressure release hole to allow pressurized air to escape the feed tube during ejection of MST from the cavity. The pressure release hole can be opened as needed to aid in passing the MST through the feed tube and to the pouching apparatus.

Brief Description of the Drawings

[0010]

FIG. 1 is a perspective view of a rotary metering device for repeatedly and consistently feeding predetermined amount of high OV tobacco to a pouching apparatus;

FIG. 2 is a side of a rotary metering device;

FIG. 3 is a top view of the rotary metering device;

FIG. 4 is a detailed side view of the rotary metering device and feed line leading to a pouching apparatus; and

FIG. 5 is a cross-sectional view in the direction of line VI-VI.

Detailed Description

[0011] An apparatus and a non-claimed method for uniformly pouching high OV tobacco is provided herein that is capable of repeatedly and consistently feeding a predetermined amount of high OV tobacco, such as moist smokeless tobacco (MST) having a moisture content of at least about 35% to about 50% or more and/or doing the same with tobacco that is tacky and difficult to feed with conventional devices, because of the presence of elevated levels of humectants, flavors, or other additives in the tobacco. Also preferably, the apparatus includes a feed system for delivering a substantially accurate quantity of moist smokeless tobacco to individual pouch wrappers in the course of their manufacture. The feed system includes a rotary metering device having at least one vacuum housing which applies a slight vacuum to cavities in a metering disk to draw a uniform amount of MST into each cavity. The vacuum is not applied at a discharge station where MST is sequentially ejected from the cavities into a feed tube for delivery of predetermined portions to the pouching apparatus at the discharge station.

[0012] As used herein, the term "moist smokeless tobacco" ("MST") refers to loose, fibrous leaf tobacco that is optionally fermented and/or optionally flavored. Preferably, the MST includes a blend of tobaccos that are cut, optionally fermented, optionally pasteurized, and/or optionally flavored. With practice of teachings herein, the MST can be fed into pouches without being dried and/or rewetted so as to substantially avoid altering the flavor and/or organoleptic properties of the MST after processing and placement in pouches for oral use. Preferably, the MST is in the form of fine cut, loose tobacco fibers having short strands ranging in length from about 0.2 mm to about 15 mm (for example, about 0.2 mm to about 12 mm, about 0.5 mm to about 10 mm, about 1.0 mm to about 8 mm, about 2.0 mm to about 6.0 mm, or about 3.0 mm to about 5.0 mm) and having a width of about 0.2 mm to about 2.5 mm (for example, about 0.2 mm to about 2.0 mm, about 0.5 mm to about 1.5 mm, or about 0.75 mm to about 1.0 mm).

[0013] As used herein, the term "fermented" refers to the transformation of a material (such as tobacco) using one or more microorganisms, such as bacteria.

[0014] As used herein, the value of "oven volatiles" or "OV" is determined by placing a weighed sample of moist botanical

material in an air-circulating oven and maintaining the sample in the oven, at a temperature of 100°C, for a period of three hours, after which the sample is again weighed. The difference in the two weight values expressed as a percentage of the original weight is defined as "oven volatiles" or "OV." Oven volatiles include water and anything that boils at a temperature of less than about 100°C.

[0015] In a preferred embodiment, an apparatus for pouching moist smokeless tobacco includes a feed system for accurately, consistently, and repetitively dosing or dispensing a predetermined quantity of MST to a pouching apparatus, such as the pouching apparatus sourced from Merz Verpackungsmaschinen GmbH, Lich, Germany, described in U.S. Patent Application Publication No. 2007/0261707, filed May 2, 2006. In the preferred embodiment, the pouching apparatus forms individual pouches, places a predetermined quantity of MST in each pouch, and forms at least one seal to contain the MST within the pouch so as to form an oral tobacco pouch product.

[0016] In the preferred embodiment, the apparatus includes a feed system that is designed to accurately dose MST so that a predetermined amount (charge) of MST is delivered to the pouching apparatus for placement in a pouch. Preferably, the feed system includes a hopper for containing or holding a supply of MST prior to conveyance to the rotary metering device. In the preferred embodiment, the tobacco feed drive is connected to a controller, which operates the tobacco feed drive.

[0017] As shown in FIG. 1, a rotary metering device 10 for repeatedly and consistently feeding predetermined amount of high OV tobacco to a pouching apparatus includes a bowl 100 and a rotatable metering disk 12. In the preferred embodiment, a bowl 100, open at the bottom, is positioned above the metering disk 12 and is adapted to hold a quantity of MST for delivering to the cavities 14. A pair of diverter plates 102 prevent the MST within the bowl from entering a discharge station 72 (shown in FIG. 3). Preferably, the bowl 100 rotates with the metering disk 12 and the lower disk 18.

[0018] The metering disk 12 includes a plurality of vertically extending through holes. The plurality of vertically extending through holes define cavities 14 within the metering disk 12. For example, the metering disk 12 can include eight substantially cylindrical cavities 14 therein. Preferably, each cavity 14 is designed to hold a predetermined amount of MST.

[0019] The metering disk 12 overlies and is connected to a rotatable lower disk 18, which rotates in unison with the metering disk 12. Through holes extend through the lower disk 18 and are aligned with the through holes in the metering disk 12. A series of pins 38 (shown in FIGS. 2A and 2B) are fixed in each of the through holes of the lower disk 18 and extend into the aligned through holes in the metering disk 12, such that an upper screen 36 of each pin 38 forms the bottom of each of the plurality of cavities 14. Preferably, the lower disk 18 includes eight radially directed passages 28 at spaced locations along the periphery of the lower disk 18. Each radial passage 28 leads to each through hole in the lower disk 18 which receives one of the pins 38.

[0020] As shown in FIG. 2A, the pins 38 are fixed in the lower disk 18 and extend into the metering disk 12. As shown in FIG. 2B, each pin 38 includes an air channel 66 through an interior thereof. In the preferred embodiment, the air channel 66 communicates through lateral port or hole 50 with a respective one of the radial passages 28 of the lower disk 18. Communication of vacuum for loading MST and blasts (pulses) of air for ejecting MST are provided to the cavities 14 in the metering disk 12 via the radial passage 28 and air channel 66.

[0021] In the preferred embodiment, the pins also include the screen 36 at the top of each pin 38, a shoulder 34, and a interior threading at the end 52 for receiving a bolt. In operation, each pin 38 is fixed to the lower disk 18 and extends into the aligned through opening in the metering disk 12. Preferably, the pins 38 can be moved vertically within the metering disk 12 to adjust the volume of the cavities 14 via the location of the screen 36, which forms the bottom of each of the cavities 14. Also preferably, each pin 38 is connected to the lower disk 18 by a bolt 70 (shown in FIG. 2A).

[0022] Also preferably, to adjust the location of the screens 36 the metering disk 12 can be moved vertically in relation to the lower disk 18 by adjusting a shaft 68 via a knob 40, which raises and lowers the metering disk 12 in relation to the lower disk 18. By adjusting the distance between the lower disk 18 and the metering disk 12, the cavity 14 fill volume 32 can be adjusted as the position of the screen 36 moves vertically within the through holes in the metering disk 12. Thus, by moving the disks 12, 18 farther apart, the fill volume 32 can be increased while moving the disks 12, 18 closer together will decrease the fill volume 32. Preferably, the drive shaft 68 is at the center axis of each of the lower disk 18 and the metering disk 12.

[0023] Preferably, the rotary metering device also includes at least one vacuum housing. In the preferred embodiment, two vacuum housings 16, 17 (shown in FIG. 3) lie on opposite sides of the lower disk 18. Also preferably, the vacuum housings 16, 17 are held in place by a key 20 which fits on a clip 22 attached to the frame 24 of the metering device 10. The key 20 and clip 22 system prevent the vacuum housings 16, 17 from rotating with the metering disk 12 and the lower disk 18 during use so as to hold the vacuum housings 16, 17 in a stationary position. The clips 22 bias the vacuum housings 16, 17 against the sides of the lower

disk 18.

[0024] In the preferred embodiment, as shown in FIG. 3, as MST is delivered to the cavities 14 at rotational positions other than the discharge station, a slight vacuum is applied to the cavities 14 to pull the MST therein and substantially fill the cavities 14. Preferably, the first vacuum housing 16 provides a first vacuum and the second vacuum housing 17 provides a second vacuum to the cavities after cessation of the first vacuum. By applying vacuum at two different times, the MST is given time to relax between pressure applications so as to avoid compacting the MST too much within each cavity 14 and/or delivering compacted MST to the pouching apparatus. Preferably, about 0.4 kPa (about 0.3 cm (about 1/8 inch) mercury) to about 2.5 kPa (about 1.9 cm (about 3/4 inch) mercury) vacuum is applied to each cavity 14 by each vacuum housing 16, more preferably about 0.85 kPa (about 0.6 cm (about 1/4 inch) mercury) to about 1.7 kPa (about 1.3 cm (about 1/2 inch) mercury) vacuum can be applied. If too much vacuum is applied, the MST has a tendency to stick to the bottom and/or walls of the cavity 14.

[0025] As shown in FIG. 4, two semi-annular vacuum housings 16, 17 are preferably diametrically opposed on the periphery of the lower disk 18 of the rotary metering device and are arranged so that two gaps 62, 76 separate adjacent ends of the vacuum housings 16, 17. As each cavity 14 is filled, it is rotated towards the discharge station 72. At the discharge position 72, MST is removed from the cavity 14 and directed to an overlying feed tube 58 by a funnel 56. The feed tube 58 supplies MST to a pouching apparatus. In the preferred embodiment, the outer surface 80 of the funnel 56 is biased against the upper surface of the metering disk 12 and aids in skimming excess MST off the top of each cavity 14 as the metering disk 12 passes thereunder to promote consistent delivery of accurate charges of MST to the pouching apparatus. Once the funnel 56 is positioned over one of the cavities 14, the funnel 56 directs the MST to the feed tube 58. A timed pulse of compressed air (air blast) from a controlled source 54 is directed into the cavity 14 at the discharge position 72 via the respective radial passage 28 of the lower disk 12, the port 50 and the air channel 66 of the respective pin 38 and through its screen 36. The pulse of compressed air ejects the MST from the cavity 14, through the funnel 56 and into the feed tube 58.

[0026] Preferably, the feed tube 58 comprises at least one pressure release hole 60 and a rotatable closure ring 62 having an aperture to adjust the size of the opening and closure of the pressure release hole 60. The pressure release hole 60 is opened incrementally if the MST is found to clump in the pouch until it is found that the MST is more uniformly distributed within the pouch. Preferably, the pressure release hole 60 is about 0.3 cm (about 1/8 inch) in diameter.

[0027] In the preferred embodiment, as discussed above, gaps 62, 76 may lie between the vacuum housings 16, 17. The gaps 62, 76 are positioned such that vacuum pressure is not applied when each cavity 14 is positioned adjacent the gaps 62, 76. Thus, the MST is allowed to relax between applications of vacuum as the bowl 100 rotates through the gap 62 so as to allow for substantially uniformly filled cavities. The interruption of vacuum is believed to help prevent the MST from being delivered to a pouch in an overly compacted condition.

[0028] In operation, tobacco of high moisture content is loaded into the bowl 100 which undergoes rotation together with the metering disk 12 and the lower disk 18. As an empty metering cavity 14 is rotated beyond the discharge station (position) 72, vacuum is communicated to the metering cavity 14 as it rotates through the angular positions in communication with vacuum applied by the vacuum housings 16, 17.

[0029] Referring now to FIG. 5, each vacuum housing 16, 17 includes arcuate bearing edge surfaces 104, 106 which conform with the periphery of the lower disk 18. The body of the vacuum housings 16, 17 are urged against the periphery of the lower disk 18 by the key 20 and clips 22. Preferably the vacuum housings 16, 17 are constructed of a hard plastic. The hollow interiors of the vacuum housings 16, 17 are communicated with a source of vacuum 108 through a pressure regulator 110 such that the vacuum may be adjusted to the aforementioned desired levels (less than 3.4 kPa (one inch mercury)).

[0030] Although it is preferred to use two vacuum housings 16, 17, a single vacuum housing 16 might be employed instead. The use of two (2) vacuum housings 16, 17 facilitates placement and removal of the vacuum housings 16, 17 for cleaning or other purposes.

[0031] A non-claimed method of pouching moist smokeless tobacco material includes loading a charge of MST into a cavity in a rotatable metering disk, applying a first vacuum to each cavity so as to substantially fill the cavity and applying a second vacuum to each cavity after cessation of the first vacuum, as the cavity rotates to a discharge station, and removing the MST from the cavity at the discharge station. Preferably, at the discharge station, the quantity of moist smokeless tobacco is ejected from the cavity through a funnel leading to a feed tube. Preferably, the method also includes conveying the moist smokeless tobacco to a reservoir above the metering disk using a tobacco feed drive system. In the preferred embodiment, the method can also include delivering the predetermined quantity of moist smokeless tobacco (MST) to a pouching apparatus using a feed tube. Moreover,

the method can include placing the predetermined quantity of moist smokeless tobacco in a pouch and sealing the pouch to contain the predetermined quantity of moist smokeless tobacco therein and form a tobacco pouch product for oral use.

[0032] The pouch forming operations can be executed by feeding a ribbon of porous outer web material through a poucher machine, such as those manufactured by Merz Verpackungsmaschinen GmbH, Lich, Germany. Such systems typically include a folding horn or shoe, a cutter and a feeder, which cooperate to repetitively fold the ribbon of porous outer web into a tube, close-off and seal an end portion of the tube, feed a measured amount of MST into the closed-off tube to create a filled portion of the tube and seal and sever the filled portion of the tube to repetitively form individual pouch products.

[0033] The disclosed embodiment is particularly suited for dispensing botanical material of high moisture content such as MST tobacco of 35% to about 50% moisture or more. The tacky nature of such materials requires the application of vacuum on the metering cavities to achieve consistent loading of the cavities because gravity alone is not sufficient. However, too much vacuum will tend to cause the botanical material to stick to the screen 36 and interferes with proper functioning of the feeder.

[0034] Additionally, such material when discharged into the funnel 56 tends to clump together to form a bolus instead of entraining with the pulse of compressed air as does a drier material. To counteract this tendency, pressure is partially relieved at a location along the feed tube via a partial or complete opening of the hole 60. The tendency of the material to form a bolus is reduced and the material is more uniformly distributed along the pouch.

[0035] As used herein, the term "about" when used in conjunction with a stated numerical value or range denotes somewhat more or somewhat less than the stated value or range, to within a range of $\pm 10\%$ of that stated.

[0036] In this specification the words "generally" and "substantially" are sometimes used. When used with geometric terms, the words "generally" and "substantially" are intended to encompass not only features which meet the strict definitions but also features which fairly approximate the strict definitions.

[0037] While the foregoing describes in detail a preferred apparatus and non-claimed methods for pouching moist smokeless tobacco with reference to a specific embodiment thereof, it will be apparent to one skilled in the art that various changes and modifications may be made to apparatus and equivalent methods may be employed, which do not materially depart from the scope of the foregoing description. Accordingly, all such changes, modifications, and equivalents that fall within the scope of the appended claims are intended to be encompassed thereby.

REFERENCES CITED IN THE DESCRIPTION

This list of references cited by the applicant is for the reader's convenience only. It does not form part of the European patent document. Even though great care has been taken in compiling the references, errors or omissions cannot be excluded and the EPO disclaims all liability in this regard.

Patent documents cited in the description

- [EPC319131A1 \[0004\]](#)
- [US20070261707A \[0015\]](#)

P A T E N T K R A V

1. Apparat til at dispensere en ladning af fugtig røgløs tobak (MST), apparatet omfattende:
en roterende måleindretning (10), den roterende måleindretning omfattende:
en roterbar nedre skive (18) omfattende en flerhed af gennemgående åbninger;
5 en roterbar måleskive (12) omfattende en flerhed af gennemgående åbninger bragt på linje med flerheden af gennemgående åbninger i den nedre skive (18) for at definere en flerhed af hulrum (14);
stifter (38) monteret i de gennemgående åbninger af den nedre skive (18) og som strækker sig ind i de gennemgående åbninger af måleskiven (12), stifterne (38) havende
10 en øvre skærm (36) som definerer bunde af flerheden af hulrum inden i måleskiven (12);
en vakuumkilde (108) til at forsyne et vakuum til hulrummene (14) under påfyldning af hulrummene (14);
en beholder (100) over måleskiven (12) til at forsyne MST til hulrummene (14) under påfyldning af hulrummene; og
15 en luftudledningsmekanisme (54) til at påføre et stød af trykluft til hver af hulrummene (14) når ved en udledningsstation (72) til at udstøde en ladning af MST derfra.
2. Apparat ifølge krav 1, endvidere inkluderende en udledningsåbning og et tilførselsrør (58) positioneret ved udledningsstationen (72) til at levere ladningerne af MST udstødt fra
20 hulrummene (14) i den roterende måleindretning (10) af luftudledningsmekanismen til et posningsapparat.
3. Apparat ifølge krav 2, hvor udledningsåbningen omfatter en tragt (56) forspændt mod en øvre flade af måleskiven (12) og i forbindelse med tilførselsrøret (58).
25
4. Apparat ifølge krav 2, hvor tilførselsrøret (58) omfatter mindst et trykudløsningshul (60).
5. Apparat ifølge krav 1, hvor den roterende måleindretning (10) omfatter mindst et
30 vakuumhus (16, 17) i forbindelse med vakuumkilden (108) og hver af stifterne (38) inkluderer en passage (66) i fluidforbindelse med skærmen (36) og vakuumhuset (16, 17).
6. Apparat ifølge krav 5, hvor passagen i stiften (38) retter luftstødet fra luftudledningsmekanismen (54) ind i et hulrum placeret ved udledningsstationen (72).
35
7. Apparat ifølge krav 1, hvor den roterende måleindretning (10) omfatter mindst et vakuumhus (16, 17) i forbindelse med vakuumkilden (108) og vakuumhuset er fastgjort til en ramme (24) og er stationært.

8. Apparat ifølge krav 1, hvor den roterende måleindretning (10) omfatter mindst to vakuumhuse (16, 17) til at påføre vakuum fra vakuumkilden (108) til forskellige grupper af hulrummene (14).

DRAWINGS

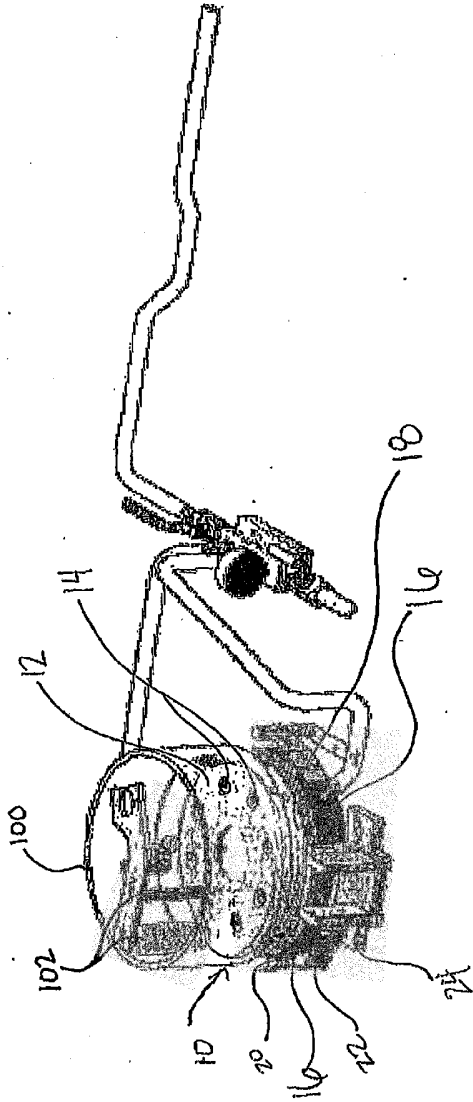

FIGURE 1

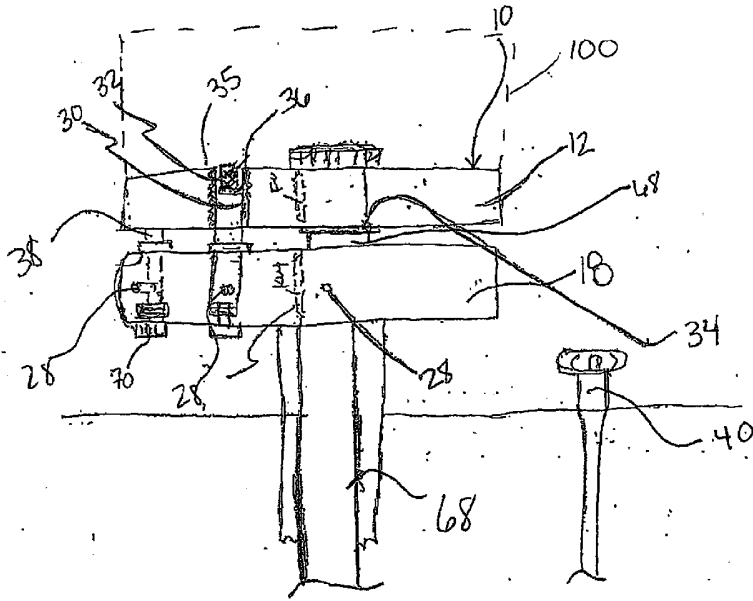

FIGURE 2A

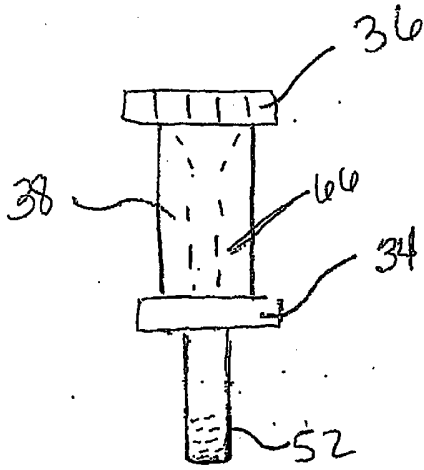

FIGURE 2B

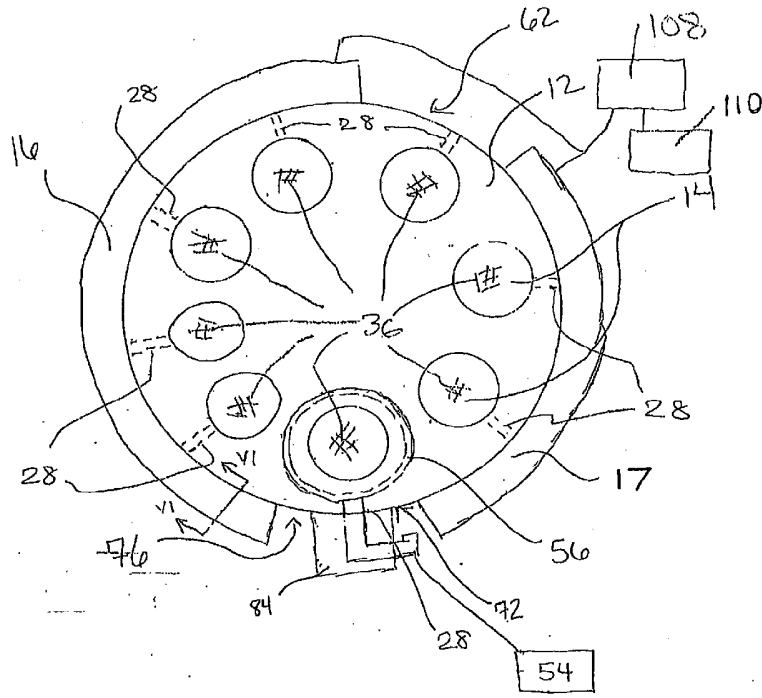

FIGURE 3

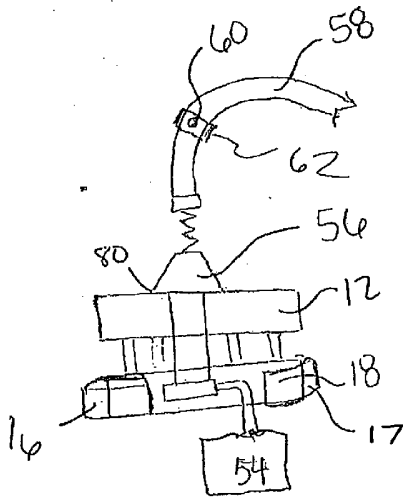

FIGURE 4

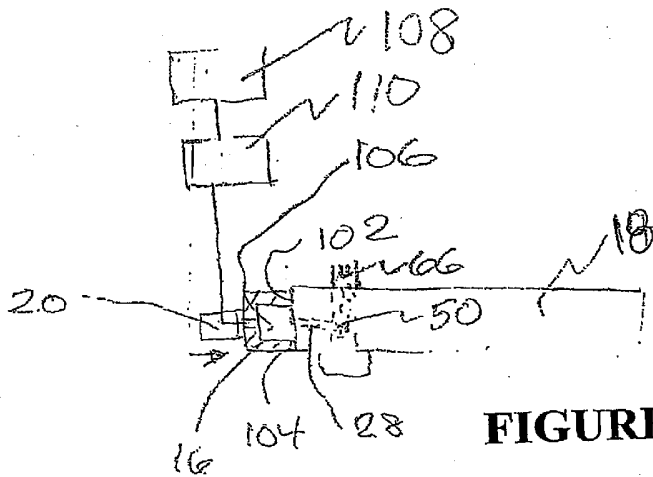

FIGURE 5