

No. 767,132.

PATENTED AUG. 9, 1904.

J. AULD.
COPY HOLDER.

APPLICATION FILED OCT. 8, 1903.

NO MODEL.

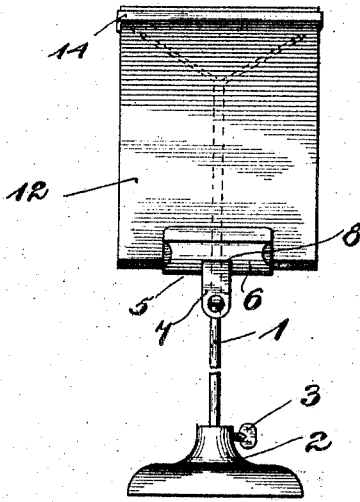

Fig. 1

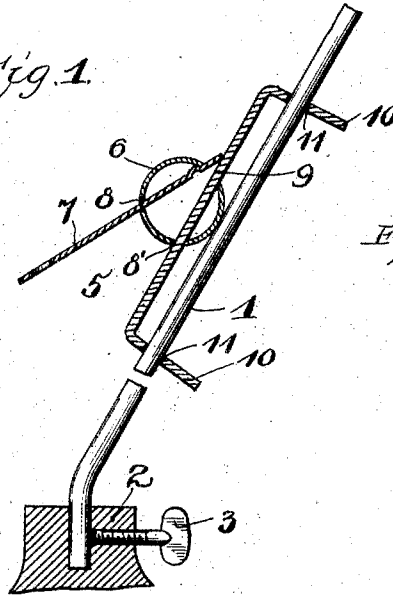

Fig. 2

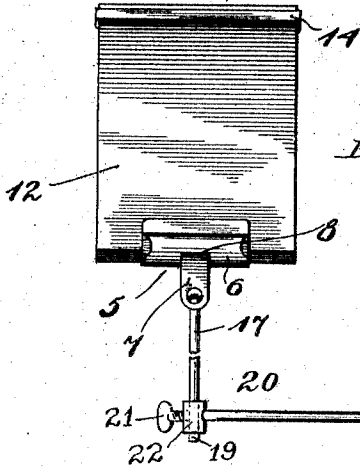

Fig. 3

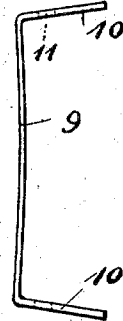
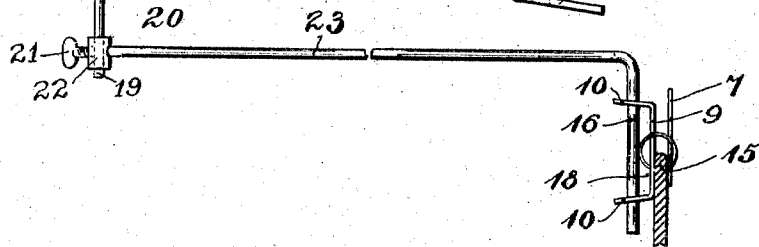

Fig. 4



Witnesses:
Ray White
Harry B. White.

Inventor:
John Auld

UNITED STATES PATENT OFFICE.

JOHN AULD, OF CHICAGO, ILLINOIS.

COPY-HOLDER.

SPECIFICATION forming part of Letters Patent No. 767,132, dated August 9, 1904.

Application filed October 8, 1903. Serial No. 176,317. (No model.)

To all whom it may concern:

Be it known that I, JOHN AULD, a subject of the King of England, residing at Chicago, in the county of Cook and State of Illinois, (whose street address is 736 West Chicago avenue,) have invented a certain new and useful Improvement in Copy-Holders, of which the following is a full, clear, concise, and exact description, reference being had to the accompanying drawings, which form a part of this specification.

Efficient copy-holders in the prior art have been very expensive, owing to the multiplicity of parts contained therein. I provide a copy-holder the essential part of which may be bought finished in the market. Said essential part consists merely of one or more spring-clips, which I may combine with a rod to form a copy-holder. Said clips are alike; but the rod may be of various shapes, adapted to attain the objects hereinafter set forth. The same form or style of clip may serve both for the purpose of holding the copy and of attaching the bar or rod on which the clip is supported to any convenient object—a type-writing machine, for instance—in any convenient position. In the prior art copy-holders designed for attachment to a type-writing machine have been provided with two distinct styles of clamp, one adapted to attach the copy-holder to the machine and the other adapted to hold the copy. My clip, which attains both these objects, consists of an ordinary spring-clip, such as may be bought in any stationery-store. I may remove one of the jaws of the clip and substitute therefor a member of different structure, which while performing the function of the substituted jaw also serves as a support. Said substituted member may, as stated, be of various shapes and sizes to accommodate itself to the different ways in which it is desired to support the copy.

My invention can better be understood by reference to the accompanying drawings, in which—

Figure 1 is a front view of one form of my device supported on a pedestal or base. Fig. 2 is a longitudinal sectional view of a clip mounted on a supporting-rod. Fig. 3 shows

a modified form of my device adapted to be secured to a type-writing machine, for instance. Fig. 4 shows an edge view of the member substituted for one of the clip-jaws.

Like characters of reference refer to like parts throughout the various figures.

In Fig. 1 I have shown the supporting-rod 1 having its lower end supported in a foot 2 and held therein by a thumb-screw 3. The part of the rod above the foot may be inclined at a convenient angle. The spring-clip 5 consists of a cylindrical spring 6 and has a jaw 7, which passes through an opening 8 in said spring, and I provide an associate jaw member 9 of modified construction which engages the spring 6 in the same manner as the jaw 7 by passing through a hole 8'. Said member 9 is provided with lugs 10, extending perpendicularly therefrom, and said lugs may be provided with holes 11, through which the rod or bar 1 may pass. The holes 11 may be so disposed that the cylindrical spring when placed on said member 9 extends beyond a line connecting the inner edges of the holes in the lugs of said member. Consequently when said member 9 is applied to the rod the spring 6 engages the rod and serves the additional purpose of holding the clip thereon and which clip is now adjustable on said rod rotatably as well as longitudinally. The upper or inclined part of the rod may also be split and fanned out, as shown in Fig. 1, or may be bent to any shape to give a better backing support for the copy grasped by the clip. Instead of directly clamping the copy a stiff support or backing 12, for instance of sheet metal, may be employed, to which the copy may be fastened, if desired, by means of a rubber band 14, for instance. Such a backing is very useful as a writing-support during the operation of taking dictation, and when it is desired to copy the notes the lower end of the backing may be inserted in the clip, thus leaving the entire leaves of the book free to be turned over.

In Fig. 3 I have shown a modified form of my copy-holder adapted to be supported from the frame of a type-writing machine, for instance. In this case I employ two clips, one for holding the copy and the other for engaging over any edge 15 of the machine, both

clips being exactly alike. The rod here embodies the vertical member 16, which is held by the clip which engages the machine, and the inclined member 17, upon which is held the clip for holding the copy. It will be seen that the clip 18 besides serving to secure the copy-holder to the machine also acts as a spring locking device for retaining the supporting-rod in any desired position of reference by the stenographer. I thus entirely eliminate the necessity of additional locking means, such as thumb-screws and the like, to attain this end. This self-locking feature adds greatly to the efficiency of the copy-holder and is also inherent with the clip supporting the copy, thus enabling me to hold the copy in any desired position of rotary or longitudinal adjustment with regard to the supporting-rod. In the prior art this locking feature could only be accomplished by the use of hinges or other forms of joint, and unless locking means—such as rivets, screws, and the like—were employed at these joints great difficulty was experienced in maintaining the copy-holder in any desired position, any jarring of the holder-support causing displacement of the copy, which is an extremely annoying feature in requiring the readjustment of the copy and the tightening of the screws. The parts 16 17 and the horizontal arm 23 may be integral, (not shown,) or, as shown in Fig. 3, for packing purposes to economize in space or for convenience when not in use I may readily manufacture it in two or more parts. For instance, I may make the part 17 to be detachable from the remaining part of the supporting-rod by the interposition of a joint 19 at the point 20 in the supporting-rod. In such case when it is desired to use the holder these parts may be joined and held together by frictional engagement or by means of a thumb-screw 21 passing through a sleeve 22, which may be disposed at the end of the horizontal arm 23. When so made, the part 17 may, it will be seen, be used in conjunction with the remaining part of the arm (shown in Fig. 3) when it is desired to secure the copy-holder to the machine, or it may be inserted and held in the foot 2 or supported in any other other convenient way when it is desired to use the copy-holder separate from the machine. When the backing is used in connection with my device, the lower end of the backing may be set on a desk and supported in an upright position by the rod, which also rests on the desk. Nor do I wish to be limited to such an arrangement of the parts of my device as will permit of the copy being inserted into the clip in a downward direction only, as shown. I may so shape the supporting-rod or so dispose the clamp on said rod as to permit of the copy being grasped at the bottom, at the top, or at the side and held in any position.

I have thus produced a copy-holder for ad-

justment to any required position and which, while embodying a minimum of parts, is very efficient, as well as very inexpensive.

I claim as new and desire to secure by Letters Patent—

1. In a copy-holder, the combination with a supporting-rod, of a spring-clip adapted for longitudinal and rotary adjustment thereon, spring means whereby said clip may be secured to said rod in any adjusted position, and a swinging arm for carrying said rod and clip, said swinging arm being adapted for separable and swinging engagement with a support, substantially as described.

2. In a copy-holder, the combination with a supporting-rod, of a clip adapted for longitudinal and rotary adjustment thereon, spring means whereby said clip may be secured to said rod in any adjusted position, a swinging arm for carrying said supporting-rod, and a spring-clip for connecting said swinging arm with a support, said spring-clip serving to secure said swinging arm in position, substantially as described.

3. In a copy-holder, the combination with a supporting-rod, of a spring-clip adapted for longitudinal and rotary adjustment on said supporting-rod, spring means for securing said clip in any adjusted position on said supporting-rod, a swinging arm for supporting said rod, an additional clip for clamping said swinging arm to a support, and spring means for securing said arm in position, substantially as described.

4. In a copy-holder, the combination with a supporting-rod, of a spring-clip adapted for longitudinal and rotary adjustment thereon, spring means for securing said clip in any adjusted position on said rod, a swinging L-shaped arm for supporting said rod, a spring-clip engaging the downwardly-extending member of said L-shaped arm, whereby said arm may be clamped to a support, and spring means associated with said clip whereby said swinging arm may be secured when swung to any position, substantially as described.

5. In a copy-holder, the combination with a supporting-rod, of a spring-clip adapted for longitudinal and rotary adjustment thereon, spring means associated with said clip for securing said clip in any adjusted position on said rod, an L-shaped swinging arm, one member of said arm terminating in a socket for engaging the lower end of said supporting-rod and clip, an additional spring-clip engaging the other end of said swinging arm for clamping said arm to a support, said additional clip being adapted for longitudinal and rotary adjustment on said end, and spring means for securing said swinging arm when swung to any position, substantially as described.

6. In a copy-holder, the combination with an L-shaped supporting-arm, of a spring-clip adapted for longitudinal and rotary adjust-

ment on the downwardly-extending member of said supporting-arm, said clip serving to engage said arm with a support, a supporting-rod having adjustable and separable engagement with the end of the horizontal member of said L-shaped arm, and a spring-clip engaging said supporting-rod, and adapted for adjustment thereon, substantially as described.

10 7. In a copy-holder, the combination with an L-shaped supporting-arm, of a clip engaging the downwardly-extending member of said arm for securing said arm to a support, said clip being longitudinally and rotatably adjustable on said member, whereby said arm

15 may swing, spring means associated with said clip for holding said arm in any position of

adjustment, a socket at the free end of the horizontal member of said L-shaped arm, a supporting-rod having rotatable and separable engagement with said socket, means for securing said supporting-rod in any rotated position, a clip engaging said rod, adapted for longitudinal and rotary adjustment on said rod, and spring means for retaining said clip in any adjusted position on said supporting-rod, substantially as described.

In witness whereof I hereunto subscribe my name this 29th day of September, A. D. 1903.

JOHN AULD.

Witnesses:

HERMAN KAACK,
D. C. GURNEE.