



US 20080156756A1

(19) **United States**

(12) **Patent Application Publication**
Ferren

(10) **Pub. No.: US 2008/0156756 A1**

(43) **Pub. Date: Jul. 3, 2008**

(54) **APPARATUS CAPABLE OF
SELF-ADJUSTING AND RETAINING A
DEVICE THEREON**

Related U.S. Application Data

(60) Provisional application No. 60/876,775, filed on Dec. 22, 2006.

Publication Classification

(51) **Int. Cl.**
A47G 25/10 (2006.01)

(52) **U.S. Cl.** 211/96

(57) **ABSTRACT**

A self-adjusting and retaining apparatus is provided having an elongated base and at least one holder rotatably connected to the elongated base. The elongated base contains means for removably connecting to a surface and at least one connection point. In addition, the holder contains at least one holder rotatably connected to the elongated base via the connection point. Further, the holder contains a back portion connected that is rotatably connected to the elongated base and extending in a first plane, a bottom portion connected to the back portion, wherein the bottom portion extends in a second plane that is not parallel to the first plane, and an end stop connected to the bottom portion of the holder, wherein the bottom portion meets the end stop at an angle.

(75) Inventor: **Justin Ferren**, Wilmont, NH (US)

Correspondence Address:
SHEEHAN PHINNEY BASS & GREEN, PA
c/o PETER NIEVES
1000 ELM STREET
MANCHESTER, NH 03105-3701

(73) Assignee: **Mesa International Corp.**, Warner, NH (US)

(21) Appl. No.: **11/962,247**

(22) Filed: **Dec. 21, 2007**

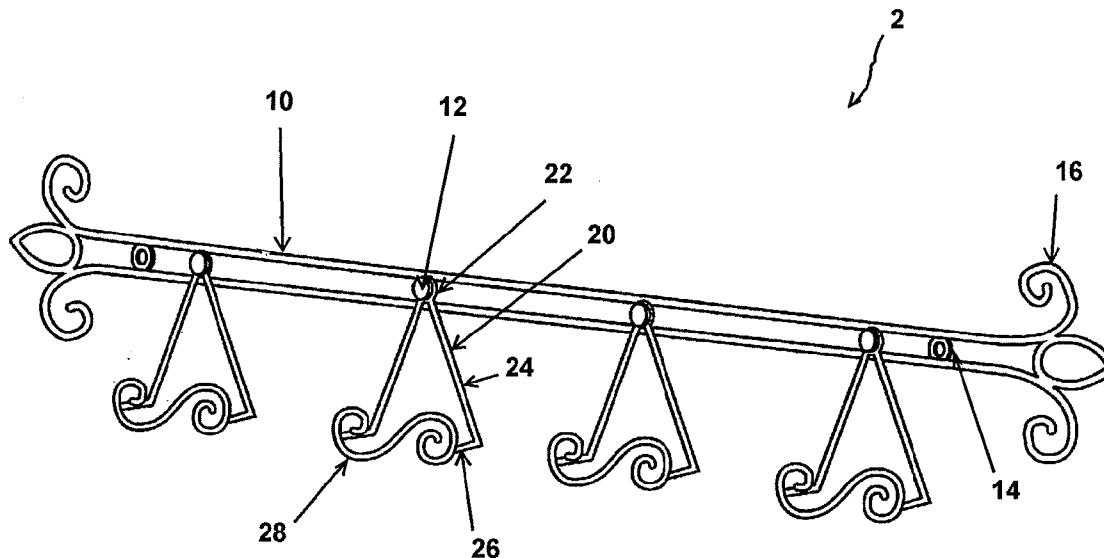

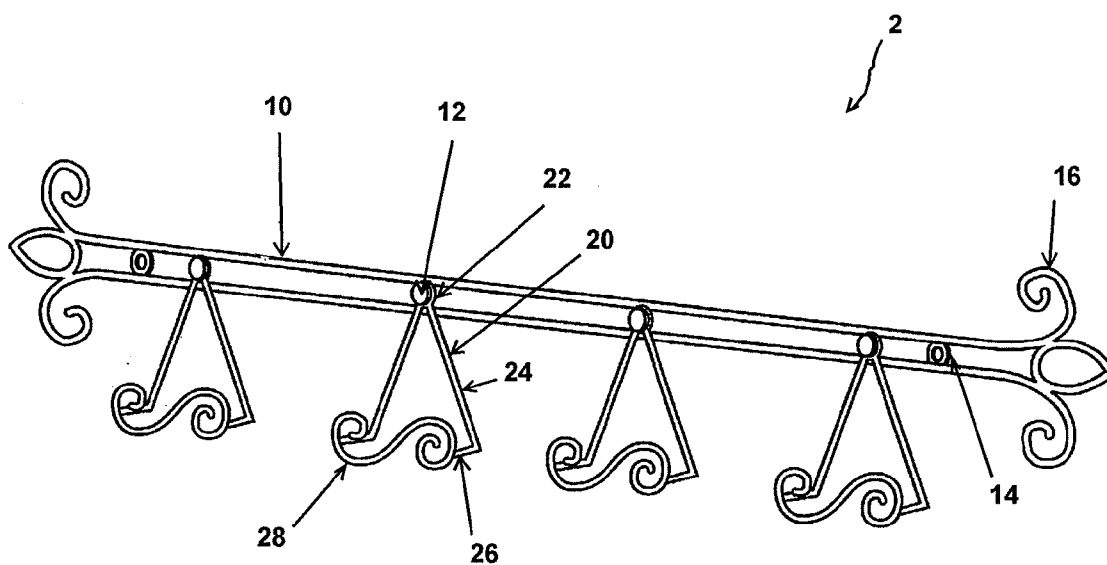

FIG. 1

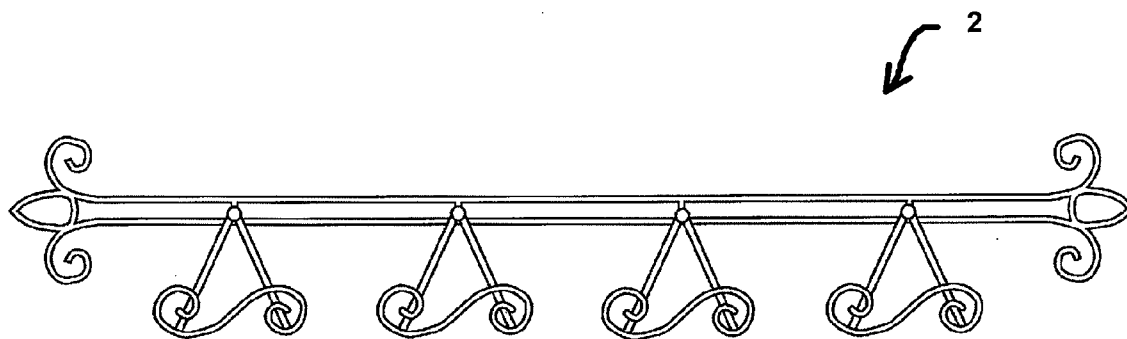

FIG. 2

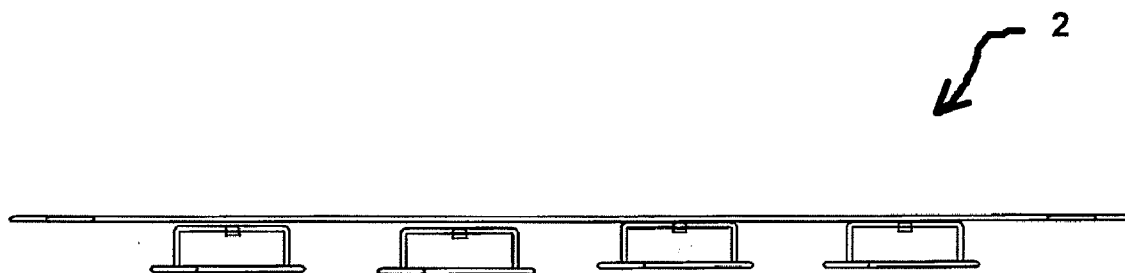

FIG. 3

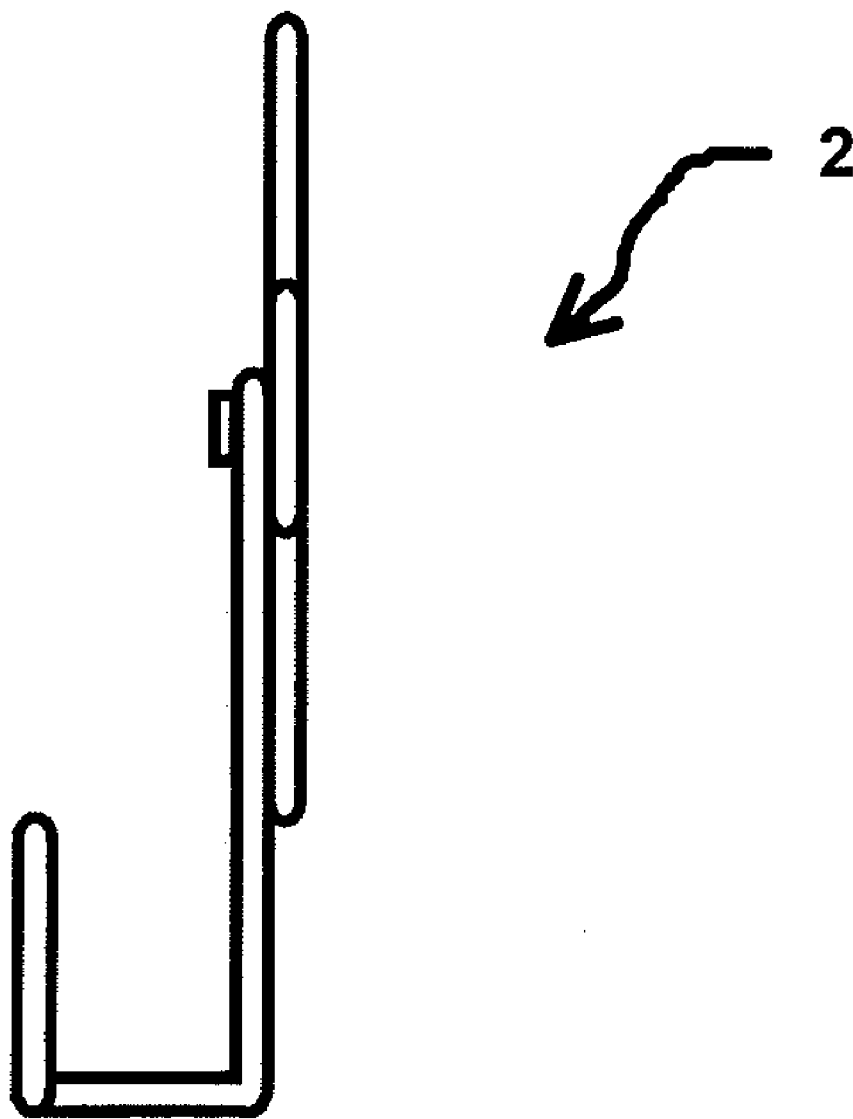

FIG. 4

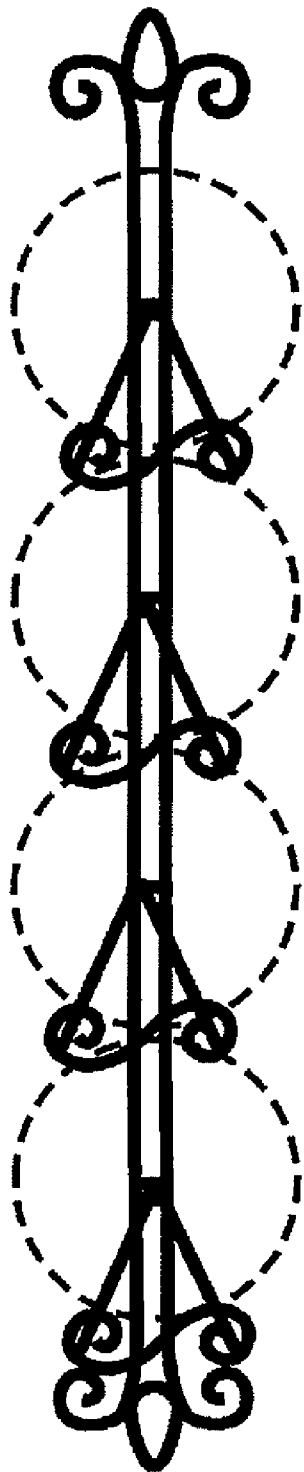

FIG. 5

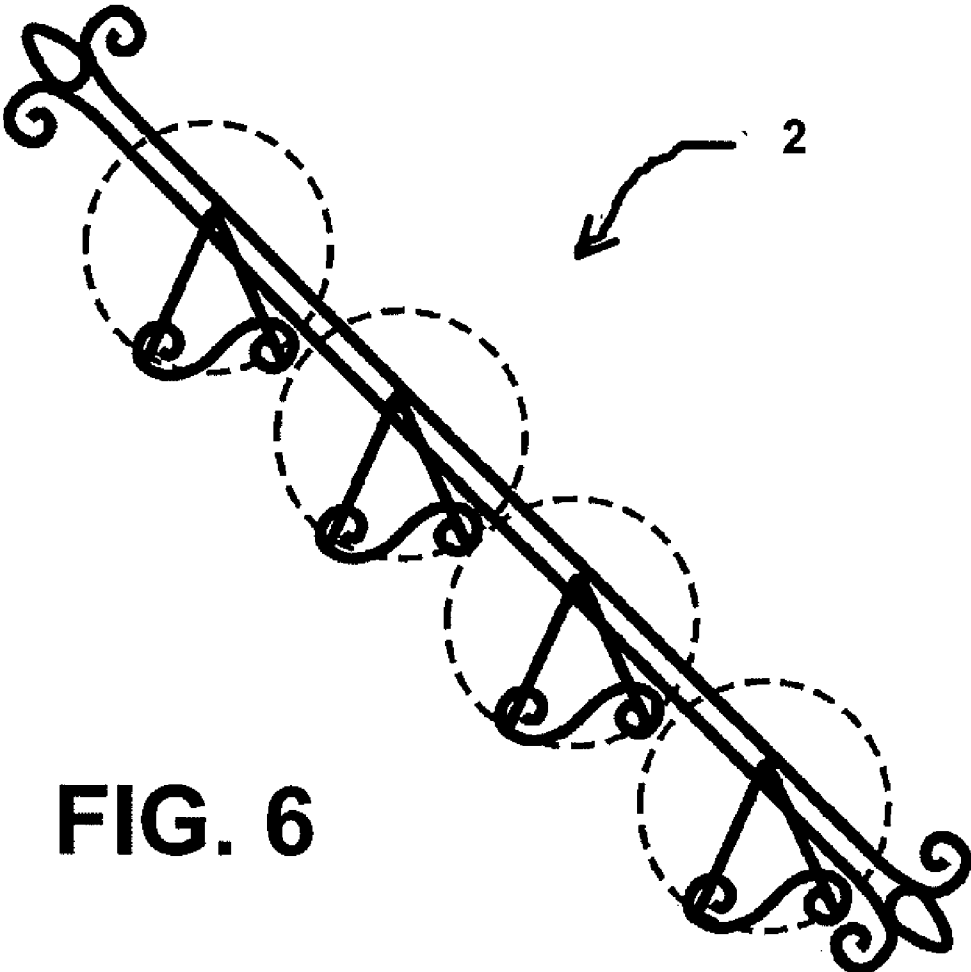

FIG. 6

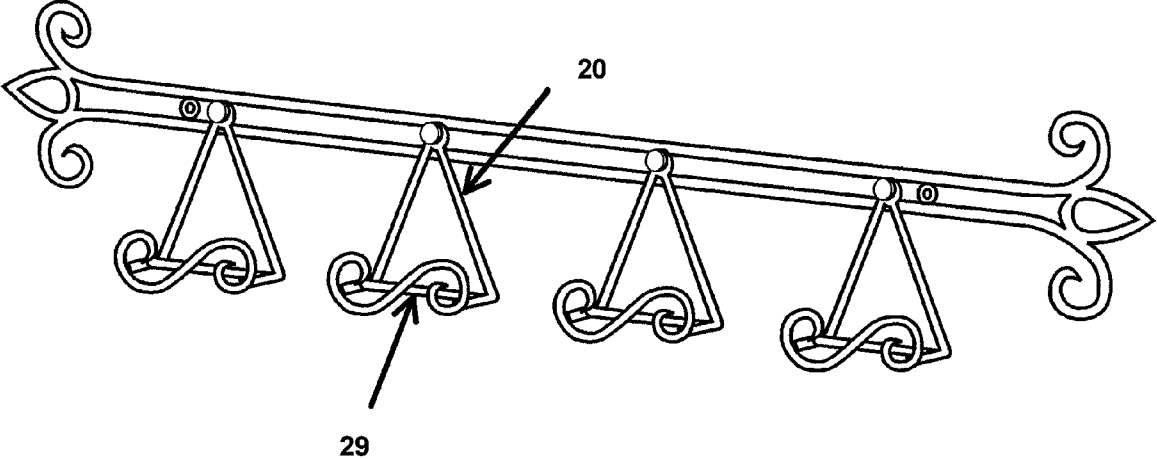

FIG. 7

APPARATUS CAPABLE OF SELF-ADJUSTING AND RETAINING A DEVICE THEREON

CROSS-REFERENCE TO RELATED APPLICATION

[0001] This application claims priority to copending U.S. Provisional Application entitled, "Self-Adjusting Retaining Structure," having Ser. No. 60/876,775, filed Dec. 22, 2006, which is entirely incorporated herein by reference.

BACKGROUND OF THE INVENTION

[0002] Typical retaining structures used for holding multiple devices in an elongated array contain an elongated base and multiple individual holders. The individual holders maintain the device being displayed in one position, where the holder has a stationary attachment to the elongated base. The stationary attachment prevents the holder from rotating out of the stationary position if the elongated base is rotated. As a result, if the elongated base is rotated clockwise or counterclockwise, the individual holders rotate with the elongated base, which may result in the devices being maintained in holders falling out of the holders.

[0003] Thus, a heretofore unaddressed need exists in the industry to address the aforementioned deficiencies and inadequacies.

SUMMARY OF THE INVENTION

[0004] Embodiments of the present invention provide a self-adjusting and retaining apparatus for maintaining an object therein regardless of whether the apparatus is maintained horizontally, vertically, or diagonally.

[0005] In accordance with an embodiment of the invention, the self-adjusting and retaining apparatus contains an elongated base and at least one holder rotatably connected to the elongated base. The elongated base contains means for removably connecting to a surface and at least one connection point. In addition, the holder contains at least one holder rotatably connected to the elongated base via the connection point. Further, the holder contains a back portion that is rotatably connected to the elongated base and extending in a first plane, a bottom portion connected to the back portion, wherein the bottom portion extends in a second plane that is not parallel to the first plane, and an end stop connected to the bottom portion of the holder, wherein the bottom portion meets the end stop at an angle.

[0006] Other embodiments and advantages of the present invention will be or become apparent to one with skill in the art upon examination of the following drawings and detailed description. It is intended that all such embodiments and advantages be included within this description, be within the scope of the present invention, and be protected by the accompanying claims.

BRIEF DESCRIPTION OF THE DRAWINGS

[0007] Many aspects of the invention can be better understood with reference to the following drawings. The components in the drawings are not necessarily to scale, emphasis instead being placed upon clearly illustrating the principles of the present invention. Moreover, in the drawings, like refer-

ence numerals designate corresponding parts throughout the several views.

[0008] FIG. 1 is a schematic diagram providing a perspective view of the present self-adjusting and retaining apparatus, in accordance with a first exemplary embodiment of the invention.

[0009] FIG. 2 is a schematic diagram, providing a front view of the present self-adjusting and retaining apparatus, in accordance with a second exemplary embodiment of the invention.

[0010] FIG. 3 is a schematic diagram, providing a top view of the present self-adjusting and retaining apparatus of FIG. 1.

[0011] FIG. 4 is a schematic diagram, providing a side view of the present self-adjusting and retaining apparatus of FIG. 1.

[0012] FIG. 5 is a schematic diagram illustrating the self-adjusting and retaining apparatus of FIG. 1 in a vertical position.

[0013] FIG. 6 is a schematic diagram illustrating the self-adjusting and retaining apparatus of FIG. 1 in a diagonal position.

[0014] FIG. 7 is a schematic diagram, providing a perspective view of the self-adjusting and retaining apparatus, in accordance with a third exemplary embodiment of the invention.

DETAILED DESCRIPTION

[0015] The present invention provides a self-adjusting and retaining apparatus that is capable of holding multiple devices in an elongated array regardless of whether the apparatus is extended in a vertical, horizontal, or diagonal orientation. While in the present disclosure the devices being held within the self-adjusting and retaining apparatus are plates (illustrated by dotted lines in certain figures), one having ordinary skill in the art will appreciate that other devices may be held in a specific position by the present self-adjusting and retaining apparatus, such as, but not limited to, picture frames. In addition, while the present retaining apparatus is shown as having four holders rotatably connected within the retaining apparatus, it should be noted that the number of holders is not limited to four. Specifically, the retaining apparatus may have additional or fewer rotatably connected holders.

[0016] FIG. 1 is a schematic diagram providing a perspective view of the present self-adjusting and retaining apparatus, in accordance with a first exemplary embodiment of the invention. The retaining apparatus 2 contains an elongated base 10, and one or more holders 20. While the elongated base 10 is illustrated as being straight, with ornamental ends, it should be noted that shape of the elongated base 10 is not important to the present invention. Instead, the elongated base 10 may be in one of many different shapes, with or without ornamental ends. In addition, if a single holder 20 is provided, the base need not be elongated.

[0017] The holder 20 is rotatably connected to the elongated base 10, so as to allow the holder 20 to rotate clockwise or counterclockwise. Preferably, the holder 20 is capable of rotating 360°. The rotatable connection between the holder 20 and the elongated base 10 is provided by a pivoting point 12. Specifically, the elongated base 10 may have, for example, but not limited to, a bolt that extends from a surface of the elongated base 10, with a bolt head located at an end of the bolt. The holder 20 may contain a pivoting connection point 22 having a hole that allows the bolt to extend therethrough. The bolt head prevents the holder 20 from falling off of the elongated base 10. One having ordinary skill in the art will

appreciate that other connection points may be provided between the holder 20 and the elongated base 10, as long as the holder 20 is capable of pivoting.

[0018] The elongated base 10 may contain other features such as, but not limited to, a wall connection point 14 and a decorative segment 16. The wall connection point 14 may be any mechanism that allows the elongated base 10 to connect to a wall or other structure. As an example, FIG. 1 illustrates a bolt-hole that can be utilized as the wall connection point 14. It should be noted, that in accordance with alternative embodiments of the invention, such as that shown by FIG. 2, the wall connection point 14, may either be a different mechanism from the bolt-hole, or nonexistent. In the example shown by FIG. 2, the elongated base 10 may be connected to a wall, simply by hanging a hook located on the wall to a portion of the decorative segment 16 or a different portion of the elongated base 10.

[0019] Returning to FIG. 1, in addition to the pivoting connection point 22, the holder 20 also contains a back portion 24, a bottom portion 26, and an end stop 28. While the back portion 24 is illustrated as being triangular in shape, it should be noted that shape of the back portion is not important to the present invention. Instead, the back portion 24 is provided for purposes of allowing a retained plate to lean backward without falling off of the holder 20. The bottom portion 26 of the holder 20 is an extension of the back portion 24, extends in a plane perpendicular to a plane of the back portion 24, and connects to the end stop 28. It should be noted that the bottom portion 26 may extend in a plane that is not perpendicular to the plane of the back portion 24, however, the plane of the bottom portion 26 cannot be parallel to the plane of the back portion 24.

[0020] The end stop 28 may be provided in one of many different decorative shapes. As an example, the end stop 28 illustrated in FIG. 1 is in the shape of an S. Specifically, the function of the end stop 28 is to maintain the plate within the holder 20 and prevent the plate from sliding downward off of the holder 20. Preferably, the end stop 28 meets the bottom portion 26 at an angle of ninety degrees or less. So as to allow for retention of a device being held by the retaining apparatus 2.

[0021] FIG. 3 is a schematic diagram, providing a top view of the present self-adjusting and retaining apparatus 2 of FIG. 1, while FIG. 4 is a schematic diagram, providing a side view of the present self-adjusting and retaining apparatus of FIG. 1.

[0022] It should be noted that adjustment in position of the holders 20 is a function of gravity so that the retaining apparatus 2 can be attached to a wall, or other structure, at any desired angle, while the holders 20 will swing to hang vertical, thereby maintaining a plate held therein for display or storage. Examples of positioning of the retaining apparatus 2 are provided by FIG. 5 and FIG. 6. Specifically, FIG. 5 is a schematic diagram illustrating the self-adjusting and retaining apparatus of FIG. 1 in a vertical position, and FIG. 6 is a schematic diagram illustrating the self-adjusting and retaining apparatus of FIG. 1 in a diagonal position.

[0023] FIG. 7 is a schematic diagram, providing a perspective view of the self-adjusting and retaining apparatus, in accordance with a third exemplary embodiment of the invention. The holder 20 of FIG. 7 contains a bar 29 located on the bottom portion 26 of the holder 20. The bar 29 assists in retaining a bottom edge of an object that is placed within the

holder 20. The location of the bar 29 prevents an object resting in the holder 20 from falling forward out of the holder 20. Specifically, the bar 29 is preferably located closer to the back portion 24 of the holder than to the end stop 28. It should be noted that the bar 29 may be located at different locations of the bottom portion 26 of the holder as long as it assists in retaining the object within the holder 20. In addition, more than one bar 29 may be located on the bottom portion 26 so as to allow more than one object to be situated within the holder 20.

[0024] It should be emphasized that the above-described embodiments of the present invention are merely possible examples of implementations, merely set forth for a clear understanding of the principles of the invention. Many variations and modifications may be made to the above-described embodiments of the invention without departing substantially from the spirit and principles of the invention. All such modifications and variations are intended to be included herein within the scope of this disclosure and the present invention and protected by the following claims.

I claim:

1. A self-adjusting and retaining apparatus, comprising: an elongated base having means for removably connecting to a surface and at least one connection point; and at least one holder rotatably connected to the elongated base via the connection point, wherein the holder further comprises;
 - a back portion, rotatably connected to the elongated base and extending in a first plane;
 - a bottom portion connected to the back portion, wherein the bottom portion extends in a second plane that is not parallel to the first plane; and
 - an end stop connected to the bottom portion of the holder, wherein the bottom portion meets the end stop at an angle.
2. The apparatus of claim 1, wherein the back portion is triangular in shape.
3. The apparatus of claim 1, wherein the apparatus contains more than one holder in an elongated array along the elongated base.
4. The apparatus of claim 1, wherein the connection between the holder and the elongated base allows for the holder to rotate in a clockwise direction and a counterclockwise direction.
5. The apparatus of claim 1, wherein the means for removably connecting to a surface is a bolt-hole.
6. The apparatus of claim 1, wherein the angle is equal to or less than ninety degrees.
7. The apparatus of claim 1, wherein the holder further comprises a bar located on the bottom portion of the holder, wherein the bar prevents an object resting in the holder from falling forward out of the holder.
8. The apparatus of claim 7, wherein the bar is located closer to the back portion of the holder than to the end stop.
9. The apparatus of claim 1, wherein the second plane in which the bottom portion extends, is perpendicular to the first plane.
10. The apparatus of claim 1, wherein the holder further comprises multiple bars located on the bottom portion of the holder, wherein the bars prevent objects resting in the holder from falling forward out of the holder.

* * * * *