

(19) World Intellectual Property Organization
International Bureau



(43) International Publication Date
16 August 2001 (16.08.2001)

PCT

(10) International Publication Number
WO 01/58553 A1

- (51) International Patent Classification⁷: A63H 3/00, 30/04, 3/40
- (21) International Application Number: PCT/US01/04268
- (22) International Filing Date: 8 February 2001 (08.02.2001)
- (25) Filing Language: English
- (26) Publication Language: English
- (30) Priority Data:
09/502,604 11 February 2000 (11.02.2000) US
- (71) Applicant: MATTEL, INC. [US/US]; 333 Continental Boulevard, El Segundo, CA 90245-5012 (US).
- (72) Inventor: TRAGESER, Mark; 1788 Garth Avenue, Los Angeles, CA 90035 (US).
- (74) Agent: EKSTRAND, Roy, A.; Mattel, Inc., Mail Stop M1-1518, 333 Continental Boulevard, El Segundo, CA 90245-5012 (US).
- (81) Designated States (national): AU, CA, MX.
- (84) Designated States (regional): European patent (AT, BE, CH, CY, DE, DK, ES, FI, FR, GB, GR, IE, IT, LU, MC, NL, PT, SE, TR).
- Published:
— with international search report
- For two-letter codes and other abbreviations, refer to the "Guidance Notes on Codes and Abbreviations" appearing at the beginning of each regular issue of the PCT Gazette.*

(54) Title: ANIMATED TOY FIGURE RESTING UPON AND RESPONSIVE TO COMPUTER MONITOR

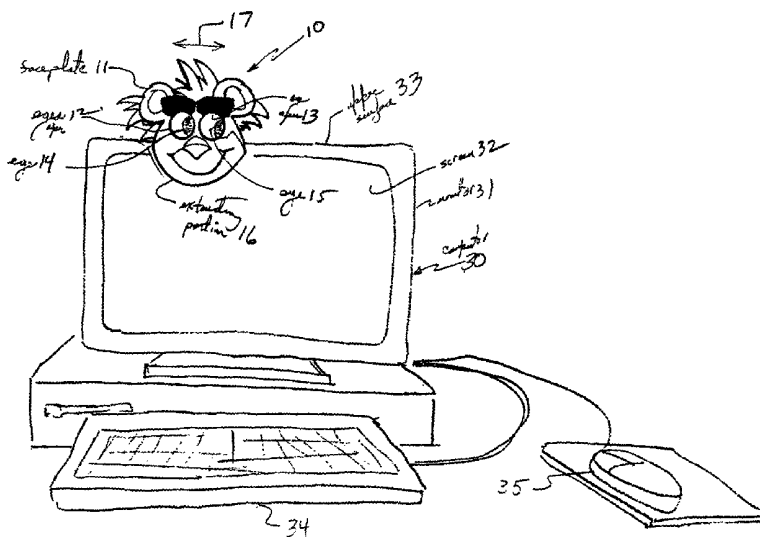

(57) Abstract: An animated toy figure (10) is constructed to rest upon the upper surface of a conventional computer (30) monitor such that a portion of the figure extends downwardly to overlie a portion of the display screen of the monitor. A light sensor (52) within the downwardly extending portion (23) of the animated figure is coupled to a sound and control circuit (55) which in turn controls the operation of a bidirectional motor (42). The figure includes an animated and articulated feature which is moved by the motor each time a particular level of light energy change is sensed by the light sensor. The animated figure responds to light changes on the computer monitor screen (32) to provide a brief period of animation and sound output.



WO 01/58553 A1

ANIMATED TOY FIGURE RESTING UPON
AND RESPONSIVE TO COMPUTER MONITOR

5

SPECIFICATION

Field of the Invention

10 This invention relates generally to animated toy
figures and particularly to those responsive to light
energy.

Background of the Invention

15

 While computers have made amazing strides in
increasing the efficiency of workers in the
marketplace and in providing amusement and
entertainment to consumers, often times persons
20 operating computers in the workplace or at home for
extended intervals are subject to fatigue and boredom.
Such extended interval use reduces the accuracy and
effectiveness of computer users as boredom and fatigue
set in. Recognizing these problems, psychologists and
25 other efficiency experts in the workplace often advise
measures such as limited time intervals of intense use
separated by short breaks and rest periods.

 In a technology related to a portion of the
30 present invention, practitioners have provided various
apparatus which respond to the light output from a
computer monitor screen in some fashion. For example,
U.S. Patent 5,823,386 issued to Vandenberg sets forth
a REWARD CANDY DISPENSER FOR PERSONAL COMPUTERS having

a candy dispensing apparatus which includes its own power source and operative mechanism to dispense candy stored therein when triggered. An amplifier circuit in the dispensing device is coupled to a photosensor element secured to the front face of a monitor screen. Light output changes from the monitor screen are amplified by the amplifier circuit and used by the control unit of the dispenser for triggering the dispensing of candy rewards.

10

U.S. Patent 5,746,602 issued to Kikinis sets forth a PC PERIPHERAL INTERACTIVE DOLL having a microphone, a speaker and control circuit to facilitate bidirectional communication with a personal computer. Scripted data stored at the computer directs doll activity and verbal articulation and utilizes responses from the child through the doll to the computer in directing output to the doll.

20

While such elaborate apparatus provides entertaining interaction with computers, there remains a continuing need in the art for a convenient, low cost and effective device for minimizing the boredom and fatigue associated with extensive computer use.

25

Summary of the Invention

Accordingly, it is a general object of the present invention to provide a device which helps to minimize fatigue and boredom by computer users. It is a more particular object of the present invention to provide a device which requires no connection or coupling to the computer in periodically amusing and entertaining the computer user.

30

In accordance with the present invention, there is provided a light-responsive toy figure for use with a computer monitor having a light-emitting display screen, the toy comprising: a housing constructed to rest upon a computer monitor having an aperture and a downwardly extending portion; a faceplate supported on the housing and defining eye apertures; a movable eye plate having eye images thereon slidably supported within the housing behind the aperture; a motor having gear means for moving the eye plate to move the eye images behind the eye apertures; a light sensor supported in the downwardly extending portion; a motor controller responsive to the light sensor to energize the motor.

Brief Description of the Drawings

The features of the present invention, which are believed to be novel, are set forth with particularity in the appended claims. The invention, together with further objects and advantages thereof, may best be understood by reference to the following description taken in conjunction with the accompanying drawings, in the several figures of which like reference numerals identify like elements and in which:

Figure 1 sets forth a perspective view of an animated toy figure constructed in accordance with the present invention positioned upon a typical computer;

Figure 2 sets forth a front view of the present invention animated toy figure having the covering face removed therefrom;

Figure 3 sets forth a section view of the animated toy figure of Figure 2 taken along section lines 3-3 therein; and

5

Figure 4 sets forth a partially sectioned top view of the animated toy figure of Figure 2 taken along section lines 4-4 therein.

10 Description of the Preferred Embodiment

Figure 1 sets forth a front perspective view of an animated toy figure constructed in accordance with the present invention and generally referenced by
15 numeral 10. Animated figure 10 is shown resting upon a conventional monitor 31 operative with a conventional computer generally referenced by numeral 30. Computer 30 is fabricated entirely in accordance with conventional fabrication techniques and utilizes
20 a keyboard 34 and a mouse 35 operatively coupled to computer 30. Monitor 31 of computer 30 is also fabricated in accordance with conventional fabrication techniques and includes an upper surface 33 upon which figure 10 rests and a monitor screen 32. Monitor
25 screen 32 provides light output as images are formed by computer 30 in conventional computer operation.

In accordance with the present invention, animate figure 10 is supported upon upper surface 33 of
30 monitor 31 by simple placement and rests there without the need for permanent attachment. In further accordance with the present invention, animated figure 10 supports a faceplate 11 which in the example of Figure 1 resembles an animal head and face. However,

it will be apparent to those skilled in the art that a variety of faceplates having a corresponding variety of appearances may be used in place of faceplate 11. For example, an entire figure body and head may be
5 fabricated to rest upon upper surface 33 in place of faceplate 11 and be operative in accordance with the apparatus set forth below. Faceplate 11 defines a pair of eye apertures 12 and 13 through which a pair of movable eyes 14 and 15 may be seen. Faceplate 11
10 further defines a downwardly extending portion 16 extends upon and partially overlies an upper portion of screen 32.

In operation, as computer 30 is being utilized by
15 a user, the light output of screen 32 is subjected to periodic variations as the images thereon are changed or moved. In accordance with the present invention and by means set forth below in greater detail, a photosensor operative behind extending portion 16 of
20 faceplate 11 receives light energy from the image changes on screen 32 and triggers the operation of an internal battery-powered motor 42 (seen in Figure 3). By means set forth below in greater detail, the triggering of the photosensor within animated toy
25 figure 10 causes energizing of the internal motor drive operative upon eyes 14 and 15 to cause eyes 14 and 15 to move back and forth behind apertures 12 and 13 in the directions indicated by arrows 17. In addition and in accordance with the preferred
30 fabrication of the present invention, this operation is accompanied by predetermined sounds stored within the control unit of toy figure 10. Thus, as the user plays or works upon computer 30, toy figure 10 periodically provides a slight interaction in response

to a predetermined level change of image upon screen 32 to emit sound and move eyes 14 and 15 back and forth. It has been found that this slight distraction occurring randomly in the view of the computer user provides the desired periodic distractions to alleviate the onset of fatigue or boredom.

Figure 2 sets forth a front view of animated toy figure 10 having faceplate 11 removed. Toy 10 includes a housing 20 having a front surface 22, a downwardly extending portion 23 and an elongated aperture 21. In accordance with the structure set forth below, figure 10 further includes a movable eyeplate 24 positioned behind aperture 21 and supporting a pair of eye images 14 and 15. In the preferred fabrication of the present invention, housing 20 is fabricated of a molded plastic material or the like.

Figure 3 sets forth a section view of animated toy figure 10 taken along section lines 3-3 in Figure 2. As described above, a computer monitor 31 includes an upper surface 33 and a display screen 32. As is also described above, animated toy figure 10 rests upon upper surface 33 and extends downwardly overlapping a portion of display screen 32.

More specifically, toy 10 includes a housing 20 defining an interior cavity 40 and a rearwardly extending plate 26. The latter is received upon surface 33. Toy figure 10 rests upon monitor 31 without attachment and is freely movable upon surface 33. Housing 20 further defines a downwardly extending portion 23 which in turn supports a light sensor

housing 50 forming a passage 51 therein. In accordance with the present invention, a light sensor 52 is supported at the upper end of passage 51. For purposes of illustration, faceplate 11 is shown in phantom line depiction secured to surface 22 of housing 20 using conventional attachment such as adhesive attachment or the like.

Front surface 22 defines an elongated aperture 21. A plurality of conventional batteries 41 are supported within interior 40 and interconnected by conventional electrical connecting apparatus (not shown). A bidirectional motor 42 having an output gear 43 is supported within interior cavity 40 by conventional means.

In further accordance with the present invention, an elongated movable eyeplate 24 defines a gear rack 25 upon its upper edge which engages gear 43. Eyeplate 24 is slidably supported within a channel 28 formed within housing 20 and engages gear 43. As a result, rotation of motor 42 rotates gear 43 and engages gear rack 25 moving eyeplate 24 back and forth within housing 20.

A sound and control circuit 55 includes conventional motor operative circuitry which moves motor 42 back and forth for a predetermined interval and provides output sound signals which are operative to drive speaker 44 (seen in Figure 4). A plurality of conventional electric circuit components such as component 56 are supported upon control circuit 55.

In operation, as light changes upon screen 32, sensor 52 responds to a predetermined level of light change and couples a signal to control circuit 55. Control circuit 55 triggers the operation of motor 42 through a predetermined cycle which in turn causes eyeplate 24 to be moved back and forth. Correspondingly, control circuit 55 outputs a predetermined sound signal which is utilized by speaker 44. In the preferred fabrication of the present invention, control circuit 55 responds to light energy of a predetermined level to energize motor 42 for a predetermined time and thereafter turn it off.

Figure 4 sets forth a partial section top view of animated toy figure 10 taken along section lines 4-4 in Figure 2. As described above, toy figure 10 includes a housing 20 having an interior cavity 40 and a rearwardly extending plate 26. Housing 20 further defines a front surface 22 having an elongated aperture 21 formed therein. A plurality of batteries 41 and a motor 42 are further supported within interior cavity 40. Motor 42 includes a gear 43.

A movable eyeplate 24 having eye images 14 and 15 formed thereon is slidably supported within channel 28 (seen in Figure 3) of housing 20 and is thus movable in the directions indicated by arrows 27. The upper edge of eyeplate 24 defines a gear rack 25 which is engaged by gear 43 to facilitate movement of eyeplate 24 when motor 42 is energized.

A sound and control circuit 55 is operatively coupled to motor 42 by conventional wiring means (not

shown) and includes a plurality of electronic components such as component 58. Circuit 55 is further coupled by a plurality of wires 45 to a speaker 44.

5

When a sufficient amount of light is sensed by light sensor 52 (seen in Figure 3), motor 42 is energized by control circuit 55 causing eyeplate 24 to move back and forth behind aperture 21 in the
10 directions indicated by arrows 27. Correspondingly, signals are coupled to speaker 44 by wires 45 from circuit 55 to cause the production of audible sounds.

What has been shown is an animated toy figure
15 which is structured to rest upon the upper portion of a conventional computer monitor. The animated toy figure responds periodically to light produced by the monitor screen to provide animated movement or action and to provide sound.

20

While particular embodiments of the invention have been shown and described, it will be obvious to those skilled in the art that changes and modifications may be made without departing from the
25 invention in its broader aspects. Therefore, the aim in the appended claims is to cover all such changes and modifications as fall within the true spirit and scope of the invention.

THAT WHICH IS CLAIMED IS:

1. A light-responsive toy figure for use with a computer monitor having a light-emitting display screen, said toy comprising:

a housing constructed to rest upon a computer monitor having an aperture and a downwardly extending portion;

a faceplate supported on said housing and defining eye apertures;

a movable eye plate having eye images thereon slidably supported within said housing behind said aperture;

a motor having gear means for moving said eye plate to move said eye images behind said eye apertures;

a light sensor supported in said downwardly extending portion;

a motor controller responsive to said light sensor to energize said motor.

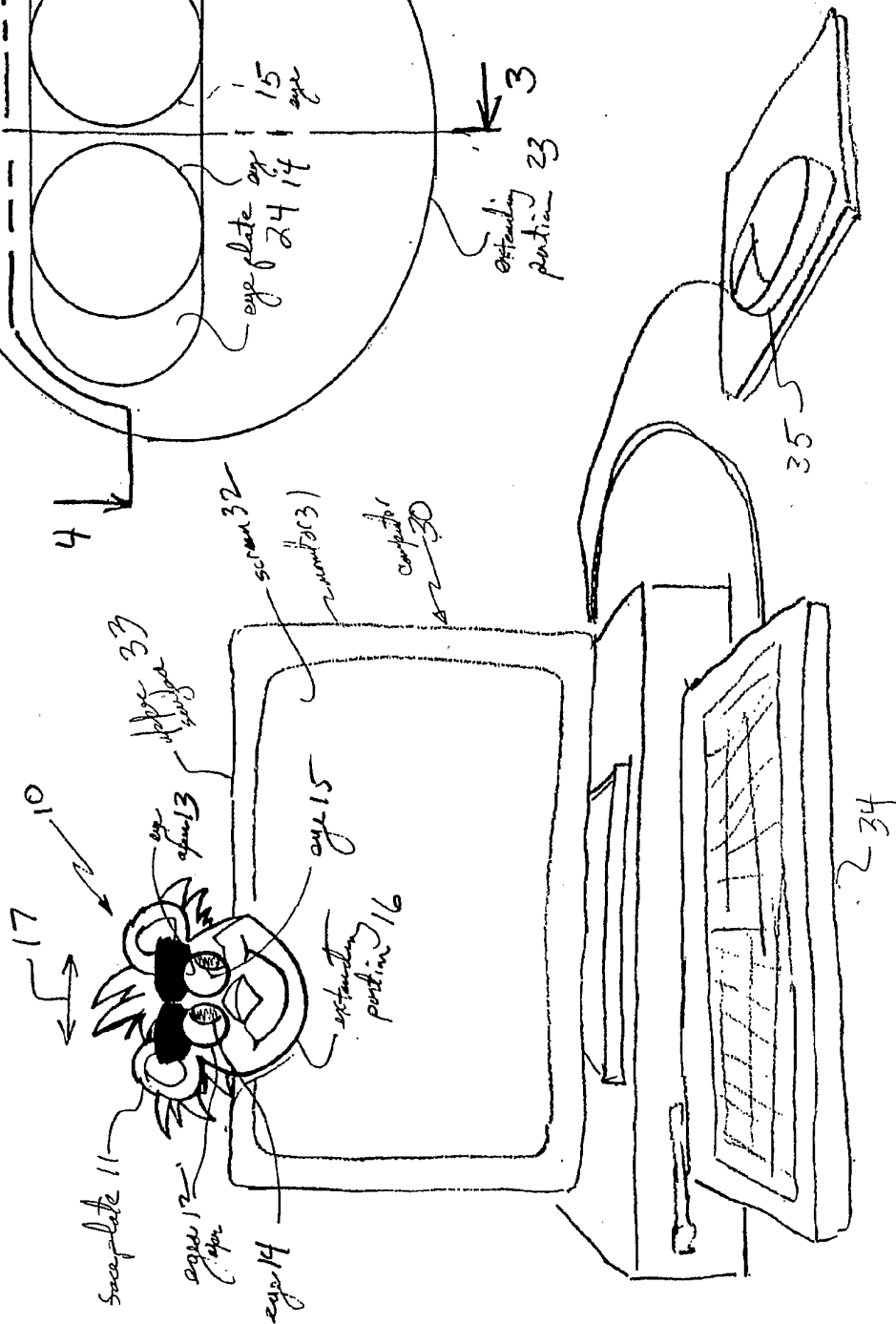
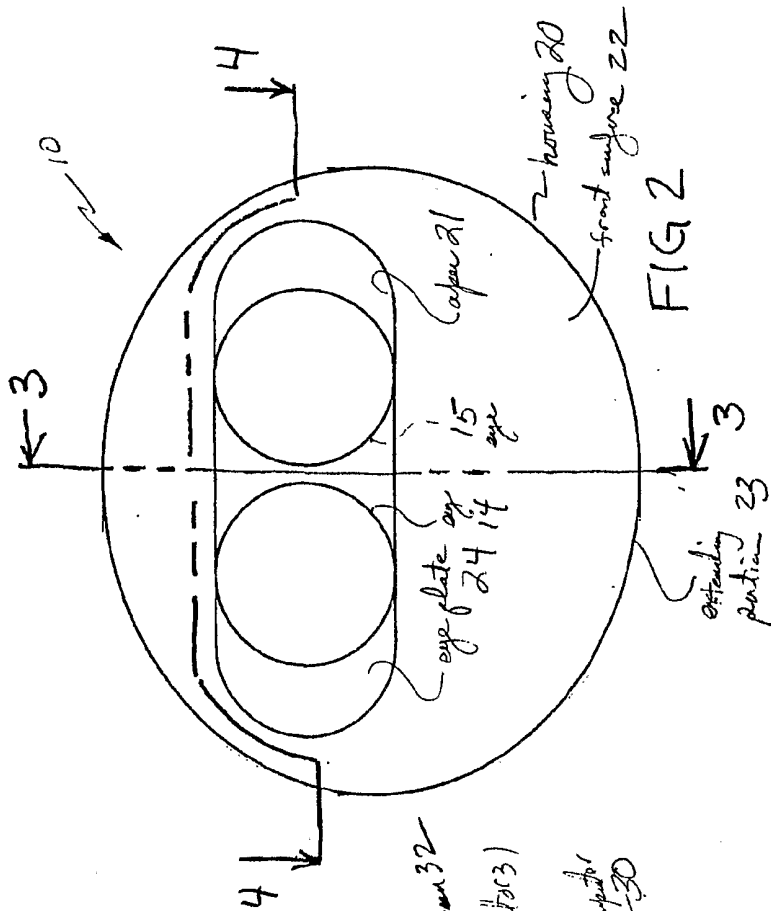

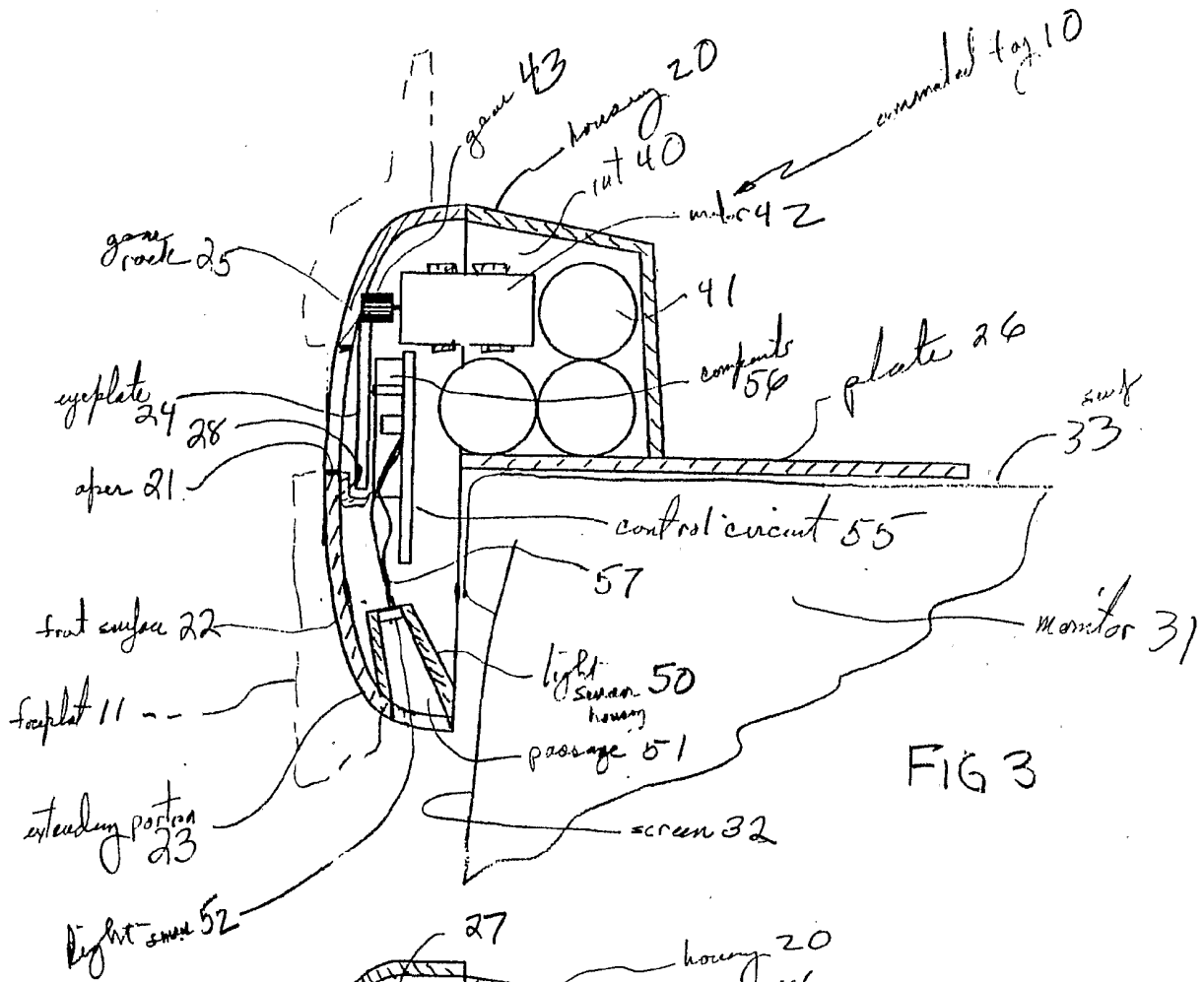

FIG 3

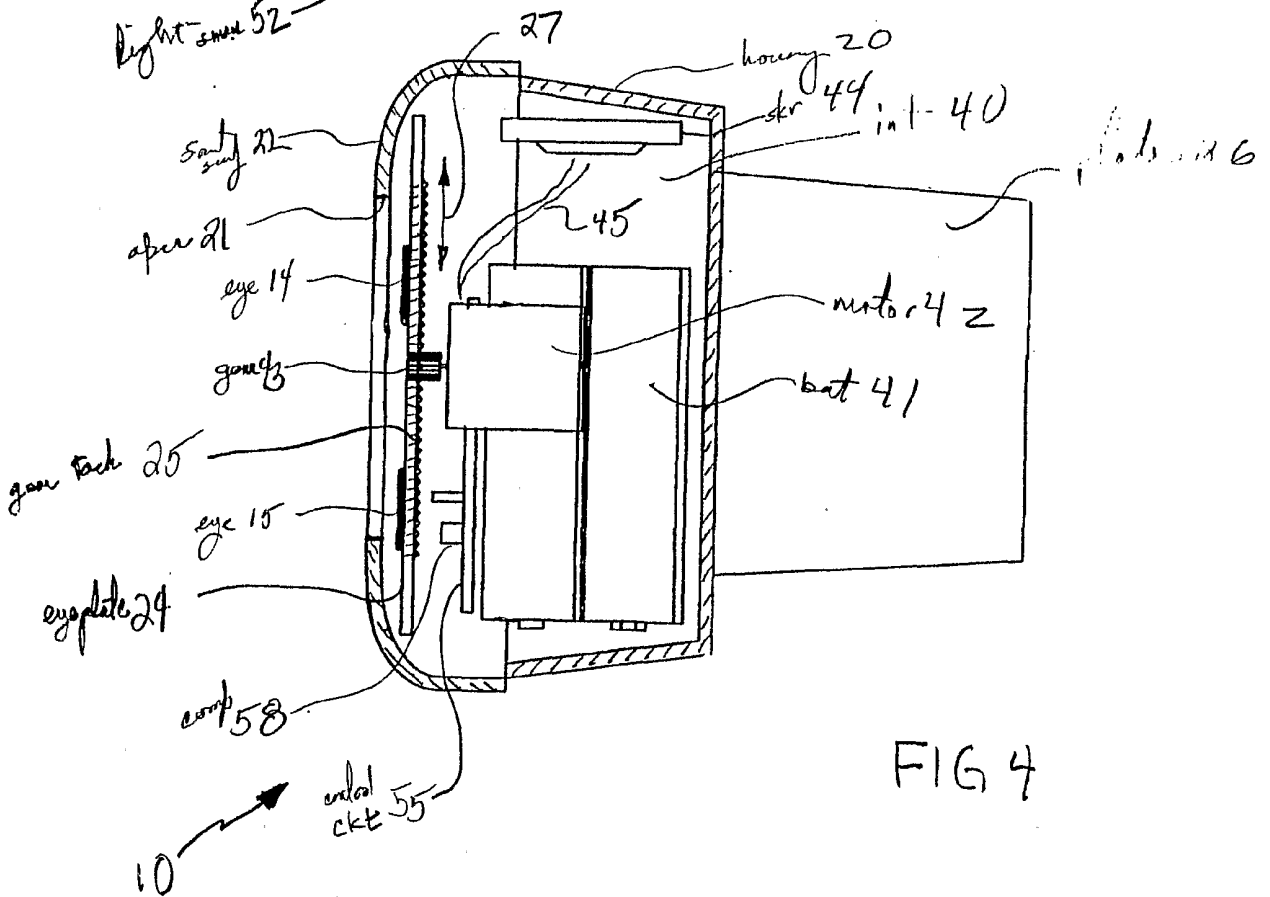

FIG 4

INTERNATIONAL SEARCH REPORT

International application No.
PCT/US01/04268

A. CLASSIFICATION OF SUBJECT MATTER

IPC(7) : Please See Extra Sheet.
US CL : 446/73,175,343

According to International Patent Classification (IPC) or to both national classification and IPC

B. FIELDS SEARCHED

Minimum documentation searched (classification system followed by classification symbols)

U.S. : 446/175,330,337,342,343,72,73

Documentation searched other than minimum documentation to the extent that such documents are included in the fields searched

Electronic data base consulted during the international search (name of data base and, where practicable, search terms used)

EAST

C. DOCUMENTS CONSIDERED TO BE RELEVANT

Category*	Citation of document, with indication, where appropriate, of the relevant passages	Relevant to claim No.
A	US 5,855,502 A (TRUCHSESS) 05 January 1999, See entire patent.	1
A	US 5,464,214 A (GRIFFIN) 07 November 1995, See entire patent.	1
A	US 5,501,627 A (EKSTEIN) 26 March 1996, See entire patent.	1
A	US 5,267,886 A (WOOD et al.) 07 December 1993, See entire patent.	1

Further documents are listed in the continuation of Box C. See patent family annex.

"A"	document defining the general state of the art which is not considered to be of particular relevance	"T"	later document published after the international filing date or priority date and not in conflict with the application but cited to understand the principle or theory underlying the invention
"E"	earlier document published on or after the international filing date	"X"	document of particular relevance; the claimed invention cannot be considered novel or cannot be considered to involve an inventive step when the document is taken alone
"L"	document which may throw doubts on priority claim(s) or which is cited to establish the publication date of another citation or other special reason (as specified)	"Y"	document of particular relevance; the claimed invention cannot be considered to involve an inventive step when the document is combined with one or more other such documents, such combination being obvious to a person skilled in the art
"O"	document referring to an oral disclosure, use, exhibition or other means	"&"	document member of the same patent family
"P"	document published prior to the international filing date but later than the priority date claimed		

Date of the actual completion of the international search

27 MARCH 2001

Date of mailing of the international search report

12 APR 2001

Name and mailing address of the ISA/US
Commissioner of Patents and Trademarks
Box PCT
Washington, D.C. 20231

Facsimile No. (703) 305-3230

Authorized officer

JACOB ACKUN

Telephone No. (703) 308-1148 *Sheila Venev*
Paralegal Specialist
Technology Center 3700

INTERNATIONAL SEARCH REPORT

International application No.
PCT/US01/04268

A. CLASSIFICATION OF SUBJECT MATTER:

IPC (7):

A63H 3/00, 30/04, 3/40