



INTERNATIONAL APPLICATION PUBLISHED UNDER THE PATENT COOPERATION TREATY (PCT)

<p>(51) International Patent Classification ⁶ : B65B 1/24</p>	<p>A1</p>	<p>(11) International Publication Number: WO 00/34126 (43) International Publication Date: 15 June 2000 (15.06.00)</p>
<p>(21) International Application Number: PCT/US99/21464 (22) International Filing Date: 15 October 1999 (15.10.99) (30) Priority Data: 09/206,250 7 December 1998 (07.12.98) US (71)(72) Applicant and Inventor: IRWIN, Eddie, N. [US/US]; P.O. Box 157, Elephant Butte, NM 87935 (US). (72) Inventor: MATHEWS, Gregory, F.; 611 Talwatha Drive, Prescott, AZ 86301 (US). (74) Agents: COTTONE, James, F. et al.; Crystal Plaza One, Suite 403, 2001 Jefferson Davis Highway, Arlington, VA 22202 (US).</p>		<p>(81) Designated States: CA, JP, MX, European patent (AT, BE, CH, CY, DE, DK, ES, FI, FR, GB, GR, IE, IT, LU, MC, NL, PT, SE). Published <i>With international search report.</i></p>

(54) Title: COMPACTION/CONTAINMENT BURIAL SYSTEM

(57) Abstract

An elongated containment tube (28) is formed to serve as a retaining means during high-pressure compaction of ash resulting from cremation of humans and animals, and thereafter as an extended service life containment system for interment. In preferred embodiments, the containment tube (28) may be made of various impervious metals, plastics, or ceramics, and employs one or more end caps (36, 36A) having a range of sealing means (38, 40) that ensure high-integrity retention of its contents. End cap sealing means, such as circumferential deformable/deforming teeth (38) and compression rings (40), are employed, and the long-term and stable burial of a large number of individual containment tubes (28) in a single, conventionally sized grave plot is described.

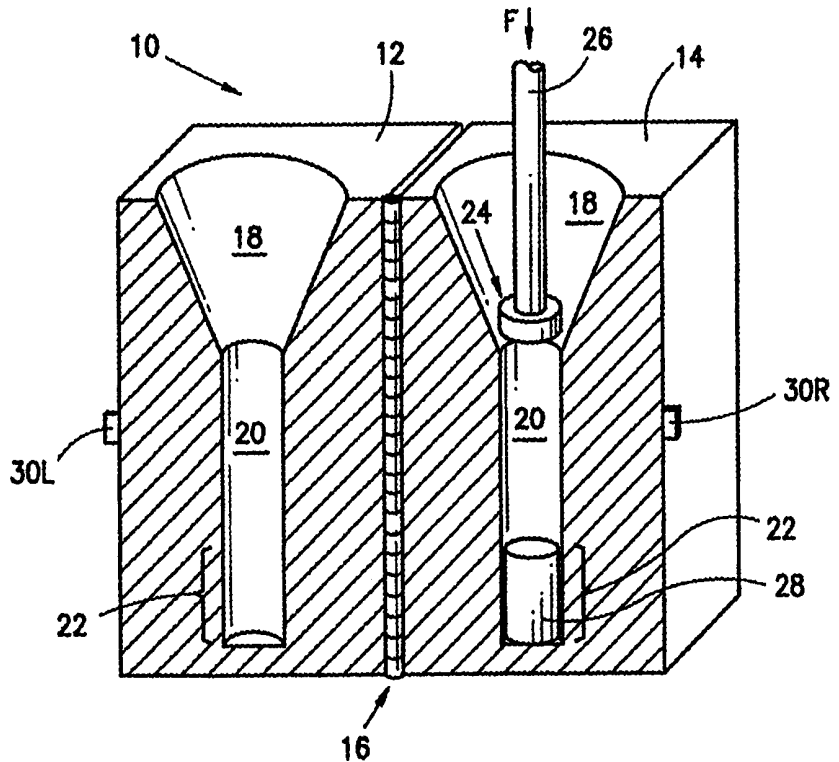

FOR THE PURPOSES OF INFORMATION ONLY

Codes used to identify States party to the PCT on the front pages of pamphlets publishing international applications under the PCT.

AL	Albania	ES	Spain	LS	Lesotho	SI	Slovenia
AM	Armenia	FI	Finland	LT	Lithuania	SK	Slovakia
AT	Austria	FR	France	LU	Luxembourg	SN	Senegal
AU	Australia	GA	Gabon	LV	Latvia	SZ	Swaziland
AZ	Azerbaijan	GB	United Kingdom	MC	Monaco	TD	Chad
BA	Bosnia and Herzegovina	GE	Georgia	MD	Republic of Moldova	TG	Togo
BB	Barbados	GH	Ghana	MG	Madagascar	TJ	Tajikistan
BE	Belgium	GN	Guinea	MK	The former Yugoslav Republic of Macedonia	TM	Turkmenistan
BF	Burkina Faso	GR	Greece			TR	Turkey
BG	Bulgaria	HU	Hungary	ML	Mali	TT	Trinidad and Tobago
BJ	Benin	IE	Ireland	MN	Mongolia	UA	Ukraine
BR	Brazil	IL	Israel	MR	Mauritania	UG	Uganda
BY	Belarus	IS	Iceland	MW	Malawi	US	United States of America
CA	Canada	IT	Italy	MX	Mexico	UZ	Uzbekistan
CF	Central African Republic	JP	Japan	NE	Niger	VN	Viet Nam
CG	Congo	KE	Kenya	NL	Netherlands	YU	Yugoslavia
CH	Switzerland	KG	Kyrgyzstan	NO	Norway	ZW	Zimbabwe
CI	Côte d'Ivoire	KP	Democratic People's Republic of Korea	NZ	New Zealand		
CM	Cameroon	KR	Republic of Korea	PL	Poland		
CN	China	KZ	Kazakstan	PT	Portugal		
CU	Cuba	LC	Saint Lucia	RO	Romania		
CZ	Czech Republic	LI	Liechtenstein	RU	Russian Federation		
DE	Germany	LK	Sri Lanka	SD	Sudan		
DK	Denmark	LR	Liberia	SE	Sweden		
EE	Estonia			SG	Singapore		

COMPACTION/CONTAINMENT BURIAL SYSTEM

Technical Field

The present invention relates generally to processing and interment of cremated remains, and in particular to
5 the compaction under high pressure of cremation ash into specially configured containment tubes to produce a highly stable and compact means suitable for long-term burial in space-efficient arrays.

Background

10 Methods and apparatus for the dignified handling and burial of human remains have a long history of development, and people worldwide have evolved a variety of rituals and processes to fulfill these solemn tasks. One universal element in virtually all approaches to interment
15 is a desire for a high degree of permanence in the processes invoked. Cremation of both human and animal remains also has a long history of usage in many cultures, and is recently becoming the process of choice for an increasingly large number of societies. Many factors are
20 contributing to the recent shift away from conventional grave-site burials toward cremation, not the least of which are practical considerations. However, given the high cultural importance of burials, the primary humanitarian criteria for interment have always, and most likely
25 will continue to prevail. These are: a universal desire for dignified handling of the deceased; a desire for permanence in the disposition of the resulting remains; and, oftentimes, a preference for a specific location for the final resting place of the remains.

30 Description of typical prior art approaches to processes and systems for producing and interment of cremated remains may be found in a number of U.S. patents.

U.S. Patents 4,781,174 to Gardner and 3,770,215 to

- 2 -

Wittke disclose processes for producing and handling cremation residues. In the 1988 Gardner patent, heat rays from the sun are concentrated and focused on a body as part of a funeral service to reduce it to ashes, and suggests presentation to the next of kin of ash compressed into a suitable urn for interment. The 1973 Wittke patent describes apparatus for receiving, cleaning, and comminuting cremation residues, and subsequently manually compressing the resulting ash into an urn.

A funiary urn in the form of a cylindrical canister is described in U.S. Patent 5,172,457 to Allen et al. The urn includes a cap having a plurality of detents that mate with a corresponding plurality of grooves in the canister's outer wall to provide a substantially gas-tight fit.

U.S. Patents 3,990,198 to Ortutay and 3,579,730 to Thompson provide teachings of post-cremation burial of human remains contained in urns. In the Ortutay patent a self-retaining barrel vault is described wherein a plurality of urn-holding elements is configured to interlockingly form the vault walls. The 1970 patent to Thompson describes an open frame structure for the interment of a plurality of individual storage tube urns containing cremated remains.

While each of these prior art approaches teaches one or another aspect of producing, processing, and burial of cremated remains, it is the unique combination of compaction/containment that the present invention admirably provides with its elegant and straightforward containment tube approach.

Objects of the Invention

It is therefore a primary object of the present invention to provide an improved compaction and containment system for handling and storing the remains of deceased human and animals.

- 3 -

A further object of the present invention is to provide a process and a system for the high compaction of cremation ash into a containment tube suitable for long-term interment.

5 A still further object of the present invention is to provide a containment tube to both facilitate the compaction of cremation ash and to serve as an extended service life container for the compacted ash.

10 A yet further object of the present invention is to provide a compaction/containment system amendable to the burial of a large plurality of extended service life containment tubes within a conventional-sized grave plot.

In baseline and alternate embodiments, an elongated containment tube of nominally constant cross section along its length is formed to serve as both a confining container during a high-pressure ash compaction step, and an extended service life container thereafter when fitted with one or more precisely formed end caps. The end cap(s) include(s) circumferentially disposed teeth-like locking means for deformably engaging the inner or outer wall surfaces of the open-ended tubular container and may further include compression rings to improve the cap/tube seal. The combination of multi-element sealing means, and selection of impervious materials for the cap/tube members, ensures the long-term integrity of the compacted remains and precludes the entry of air, water, and other ambient contaminants. Burial of a large number of these hermetically sealed, long-life containment tubes containing the remains of related family members are preferably arrayed in a conventionally sized grave plot.

15
20
25
30

Brief Description of the Drawings

Additional objects and advantages of the invention will become apparent to those skilled in the art as the description proceeds with reference to the accompanying

- 4 -

drawings wherein:

FIG. 1 is a schematic view of a compression assembly for compacting the cremated remains of a human or pet into virtually solidified form according to the present invention;

FIG. 2 is a cross-sectional view of a containment tube for use with the present invention;

FIG. 2A is a partial cross-sectional view of sealing means for a containment tube cap;

FIG. 2B is a simplified schematic view of an alternate form of the end cap/containment tube interface;

FIG. 3 is a top plan view of a grave-sized site for the interment of a plurality of individual containment tubes of cremated remains;

FIG. 4 is a cross-sectional view of the grave site of FIG. 3 taken along the lines 4-4; and

FIG. 5 is a cross-sectional view of the grave site of FIG. 3 taken along the lines 5-5.

Best Mode for Carrying out the Invention

Referring now to FIG. 1, there is shown a compression assembly for compacting the ash that results from the cremation of humans or pets - hereinafter referred to as cremains - into solidified form according to the present invention. The assembly 10 is formed of two virtually identical half mold sections 12 and 14, which are pivotally interconnected by a piano hinge 16. The assembly 10 is shown in the opened position with each half section including a funnel-shaped input portion 18 at its upper end, a central compression shaft portion 20, and a containment tube region 22 at its lower end. The right half section 14 shows a compaction ram 24 adapted to be urged downward through the shaft portion 20 responsive to a compression force F applied via an input shaft 26. A cylindrical containment tube 28 is positioned in the

- 5 -

region 22 of the half section 14.

In use, the assembly 10 is prepared to compress cremains by the emplacement of an empty containment tube in the region 22, pivoting the two half sections together and retaining them by a pair of latch members 30L and 30R, and slightly elevating the ram 24. Thereafter, cremains of an individual are poured into the input portion 18 to arrive in loose form into the containment tube 28, and may also partially extend into the lower end of the shaft portion 20. Upon application of the compression force "F" by any suitable means, such as hydraulic, pneumatic, or mechanical urging, the cremains are tightly compacted into the containment tube 28. Suitable choices of tube sizes, applied forces, and strengths of the compression tube and compression assembly ensure that the cremains are optimally compacted into containment tube 28. Compaction under high pressure not only produces a highly solidified ash, but also improves the long-term stability of the cremains and facilitates their indefinite storage.

An illustrative containment tube is described with reference now to FIG. 2. A cylindrical tube 28 having integrally formed sidewalls 32 and bottom end 34 is configured as an open-topped container of height "H" and diameter "D." In a preferred embodiment, the tube 28 is formed of stainless steel to provide a hermetically sealable container when fitted with a precisely machined tube cap 36. The cap 36 may include one or more circumferentially disposed locking teeth 38 and a compression ring 40, as shown in enlarged scale in a partial cross-sectional view of FIG. 2A. Typical overall tube dimensions are contemplated to be in the range of 2-6 inches in diameter and 6-12 inches in length. After the cremains have been compacted into containment tube 28, the filled tube is sealed by firmly urging the end cap 36 into the open tube top. The locking teeth 38 slightly deform the

- 6 -

tube walls upon insertion, ensuring a tight mechanical grip of high integrity that does not yield over time, and the compression ring 40 of neoprene or other resilient materials ensures a hermetic seal. In preferred embodiments, various combinations of well-known sealing means beyond those shown here may be employed to ensure a seal impervious to air and water penetration. Sealing means adequate to support burial at sea or underwater are also contemplated.

Other alternate containment tube arrangements may include the use of a pair of end caps 36A which are compression-fitted over the outer walls of an open-ended sleeve-like container 28A, all as depicted in FIG 2B. The end caps 36A may also include deformable teeth-like locking means (not shown to scale) as in those of FIG. 2A, as well as other well-known sealing means including one or more compression rings.

The cylindrical containment tube described thus far represents a preferred but baseline embodiment, and a number of variants are contemplated with respect to both the shape and materials that may be employed. Beyond the well-known desirable properties of stainless steel, the containment tube 28 may also be formed of other metals, such as aluminum, brass, and bronze. Molded ceramics and high-strength plastics may also serve well. Regarding shape, a range of alternate forms may readily be substituted for the baseline cylinder, such as elongated tubes having hexagonal, rectangular, or other cross sections. It is, however, desirable for best compaction that the cross section chosen be amenable to accommodating the compacting process without causing undue localized deforming stresses on the tube walls. This factor favors the use of tubes having cross sections more or less uniform over the tube length, but does allow for conical or pyramidal shapes of shallow side slopes. In

- 7 -

considering the shape and materials for the containment tube 28, primary considerations lead to a choice of materials that provide a robust container of superior long-term stability that is hermetically sealable so as to provide containment impervious to contaminating ambient conditions, and shapes that provide a dignified and aesthetically pleasing repository for cremains.

In keeping with the containment burial aspect of the present invention, a number of approaches are contemplated, all having in common the interment of a plurality of containment tubes within a limited-sized burial plot. For illustrative teachings of post-cremation, above-ground burial arrangements, the interested reader is referred to the aforementioned U.S. Patents 3,990,198 to Ortutay and 3,529,730 to Thompson. The Ortutay patent (issued in 1976) shows a system for sepulchral urn burial wherein a large number of individual urns are arrayed in separate blocks that form the sloping walls of a barrel vault. The Thompson patent (issued in 1970) shows a more conventional open-framed structure that supports a plurality of storage tubes for the interment of individually identified cremated remains.

Referring to FIGS. 3-5, a conventionally sized gravesite arrangement is shown for accommodating a large number of individual containment tubes. In the top view of FIG. 3, a horizontal array of vertically disposed tube-receiving openings 42 are shown fitted into a 2-foot by 6-foot plot. Reference to the lateral cross-sectional view of FIG. 4 shows the depth of each opening 42 to be just under 4 feet, thereby allowing the emplacement of approximately six individual containment tubes. For the illustrative 4 x 12 horizontal array of openings depicted, a large number of burial spaces are available, and each burial opening may hold up to six family members. This approach is considered particularly auspicious, because it

- 8 -

permits a smooth integrating of interment modes by the utilization of existing grave plots in present-day cemeteries.

5 Although the invention has been described in terms of
selected preferred embodiments, the invention should not
be deemed limited thereto, since other embodiments and
modifications will readily occur to one skilled in the
art. It is therefore to be understood that the appended
claims are intended to cover all such modifications as
10 fall within the true spirit and scope of the invention.

- 9 -

Claims

1. A process for compaction and containment of cremains comprising:

5 (a) providing a containment tube having at least one end opening and adapted to be sealed by the mating of an end cap with said end opening;

(b) compacting a predetermined amount of cremains placed into said containment tube;

10 © providing at least one end cap and sealing said containment tube by mating said end cap with said at least one end opening; and

(d) whereby one or more containment tubes filled with compacted cremains may be interred for long-term burial in reduced space.

2. The process of Claim 1 wherein said containment tube is an elongated cylindrical tube having one open end and said compacting step is accomplished by insertion of compacting means through said open end.

3. The process of Claim 2 wherein said end cap is disk-shaped and includes deformable means distributed circumferentially around its outer surface for providing an airtight sealing of said containment tube.

4. The process of Claim 3 wherein said end cap further includes a circumferential compression ring to provide additional sealing of said containment tube.

5. The process of Claim 1 wherein said amount of cremains is derived from a single individual human or animal.

6. The process of Claim 5 wherein a plurality of

- 10 -

containment tubes, each containing cremains of an individual, are interred in a single conventionally sized burial plot.

5 7. The process of Claim 1 wherein said containment tube is an elongated container having a uniform cross section along its elongated axis whereby said compacting step is facilitated without the creation of highly non-uniform stresses in said containment tube.

8. The process of Claim 7 wherein said uniform cross section is selected from the group of rectangular, hexagonal, or other regular polygonal shapes.

5 9. The process of Claim 1 wherein said containment tube is formed as an elongated sleeve of uniform cross section having both ends open and adapted to be sealed by a pair of end caps, each end cap including at least one circumferentially disposed deformable element for providing an airtight sealing when forcible mated with its corresponding end opening.

10. The process of Claim 1 wherein at least one of said end caps is sized so as to fit within said sleeve open end to provide said sealing.

11. A system for compaction and containment of cremains derived from ash resulting from the cremation of humans or animals, comprising:

5 (a) a compression assembly formed from two half mold sections pivotally interconnected along a longitudinal axis to form an interior chamber when pivoted to a closed position, and a compaction ram moveable within said chamber under the urging of an externally applied force;

(b) said interior chamber being symmetrical about a

- 11 -

10 longitudinal axis and having an input portion at its upper
end, a central compression portion and a containment tube
region at its lower end;

(c) a containment tube of impervious material having
at least one open end and adapted to fit within said
15 containment tube region;

(d) said compaction ram moveable longitudinally
responsive to said force from said input portion to said
containment tube region;

(e) whereby upon depositing cremains into said input
20 portion and actuating said compaction ram, the cremains
are compressed into said containment tube, and upon
subsequently opening said two mold sections to an open
position, said cremains containing containment tube is
removable for interment.

12. The system of Claim 11 wherein said interior
chamber includes a funnel shaped input portion, an
elongated cylindrically shaped central portion and an
elongated cylindrically shaped containment tube region,
5 and said compaction ram is formed as a truncated
cylindrical ram portion actuated by an elongated shaft
portion.

13. The system of Claim 12 wherein said externally
applied force is selected from the group containing
hydraulic, pneumatic and mechanical forces.

14. The system of Claim 11 wherein said half mold
sections are pivotally interconnected via a two part piano
hinge longitudinally disposed along substantially the full
vertical extent of said two sections.

15. The system of claim 14 wherein each of said two
half mold sections includes cooperating locking means .

- 12 -

disposed along a mold edge oppositely disposed to the mold
edges carrying said piano hinge parts, whereby said two
5 half mold sections are securely retained upon being
pivoted via said piano hinge to a closed position.

FIG. 1

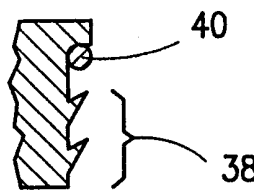
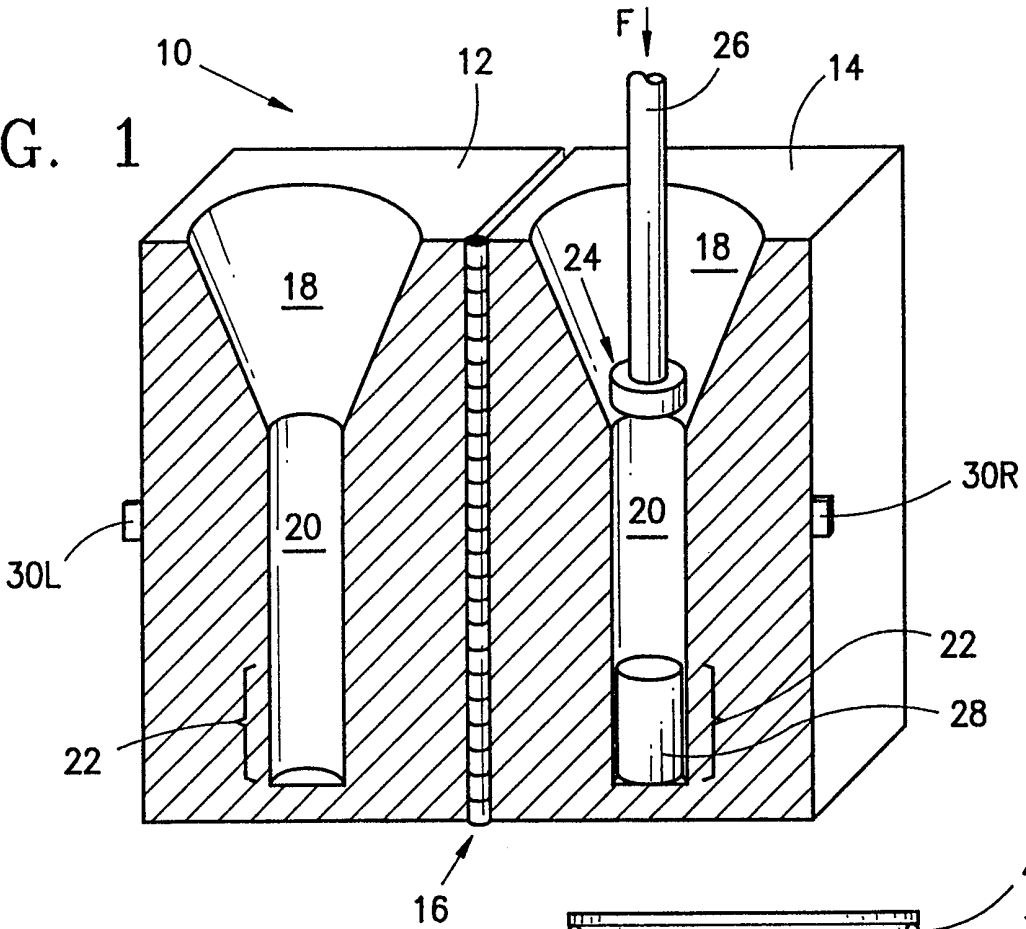

FIG. 2A

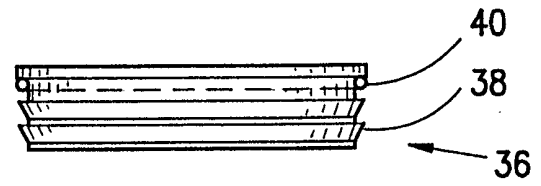

FIG. 2

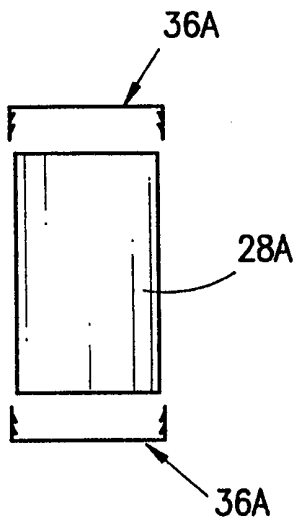
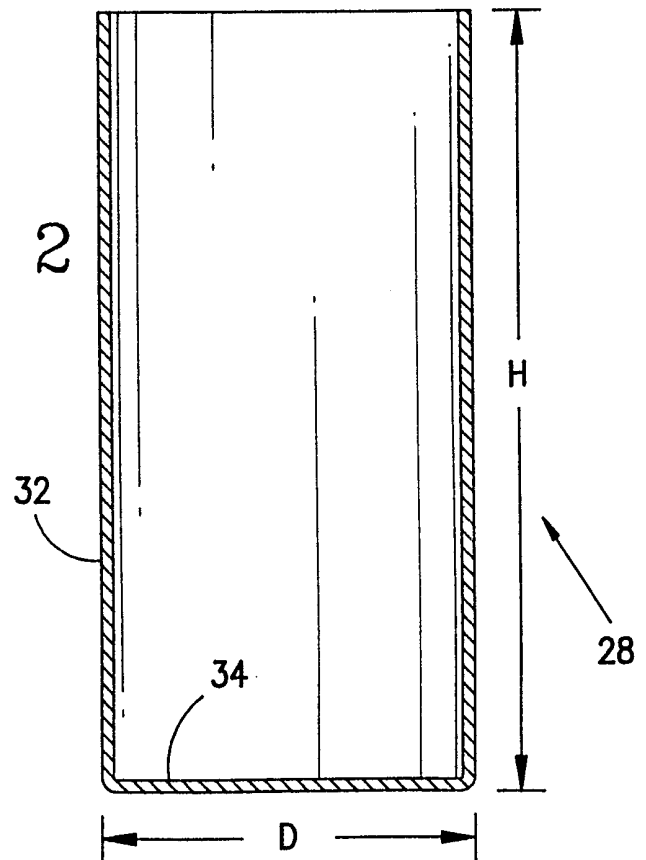

FIG. 2B



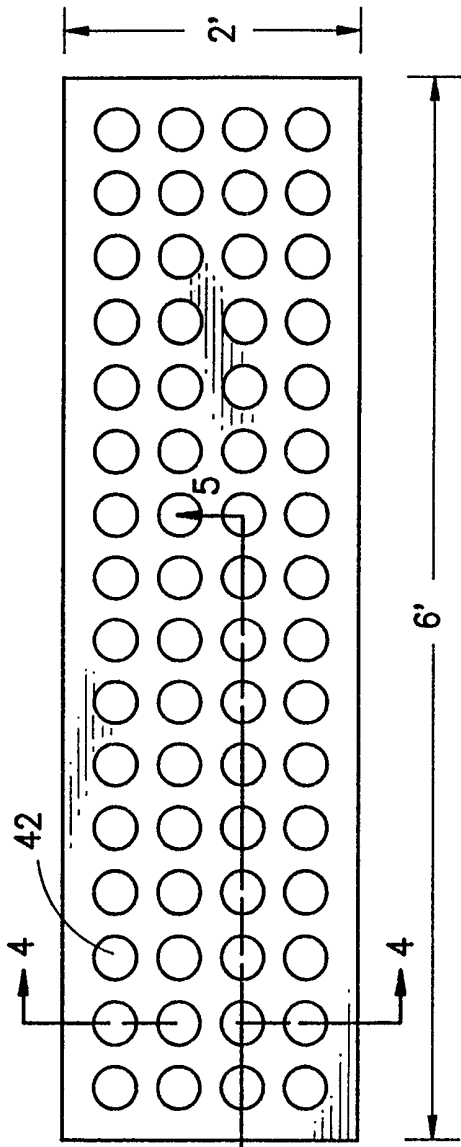

FIG. 3

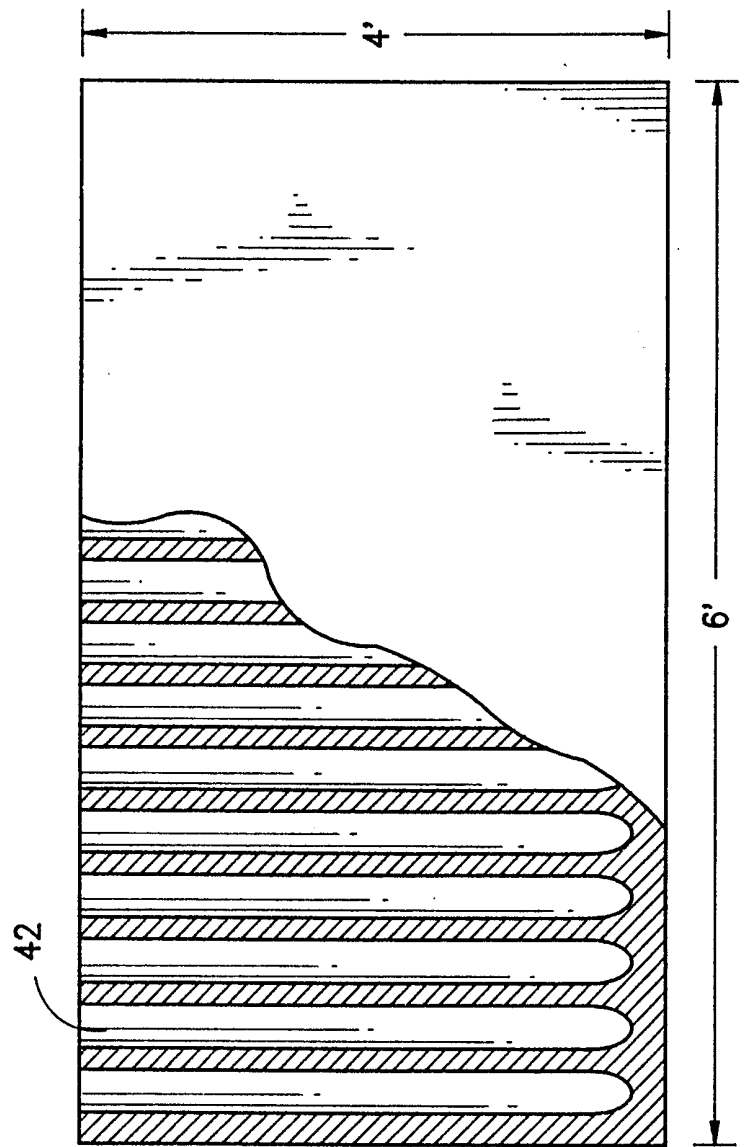

FIG. 5

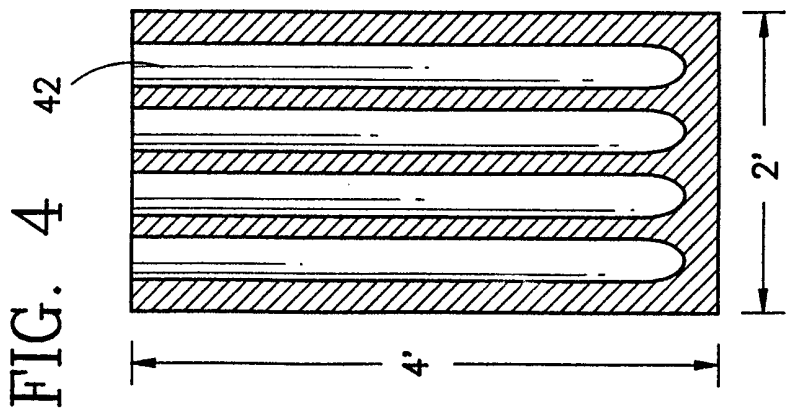

FIG. 4

INTERNATIONAL SEARCH REPORT

International application No.
PCT/US99/21464

A. CLASSIFICATION OF SUBJECT MATTER

IPC(6) :B65B 01/24
US CL :53/436, 527

According to International Patent Classification (IPC) or to both national classification and IPC

B. FIELDS SEARCHED

Minimum documentation searched (classification system followed by classification symbols)

U.S. : 27/1, 2, 35; 52/136; 53/436, 527; 110/194

Documentation searched other than minimum documentation to the extent that such documents are included in the fields searched

Electronic data base consulted during the international search (name of data base and, where practicable, search terms used)

C. DOCUMENTS CONSIDERED TO BE RELEVANT

Category*	Citation of document, with indication, where appropriate, of the relevant passages	Relevant to claim No.
X	US 1,373,014 A (MOORE) 29 March 1921, entire document.	1-10
X	US 3,654,675 A (PETERSON) 11 April 1972, entire document.	1-10
Y	US 4,893,385 A (SCHRAG) 16 January 1990, entire document.	1-10
Y	US 4,977,652 A (GRAHAM) 18 December 1990, entire document.	1-10
Y	US 3,770,215 A (WITTKE) 06 November 1973, entire document.	1-15
Y	US 4,559,870 A (KRUMMACHER et al) 24 December 1985, entire document.	11-15

Further documents are listed in the continuation of Box C. See patent family annex.

* Special categories of cited documents:	"T" later document published after the international filing date or priority date and not in conflict with the application but cited to understand the principle or theory underlying the invention
"A" document defining the general state of the art which is not considered to be of particular relevance	"X" document of particular relevance; the claimed invention cannot be considered novel or cannot be considered to involve an inventive step when the document is taken alone
"E" earlier document published on or after the international filing date	"Y" document of particular relevance; the claimed invention cannot be considered to involve an inventive step when the document is combined with one or more other such documents, such combination being obvious to a person skilled in the art
"L" document which may throw doubts on priority claim(s) or which is cited to establish the publication date of another citation or other special reason (as specified)	"&" document member of the same patent family
"O" document referring to an oral disclosure, use, exhibition or other means	
"P" document published prior to the international filing date but later than the priority date claimed	

Date of the actual completion of the international search 02 DECEMBER 1999	Date of mailing of the international search report 11 JAN 2000
Name and mailing address of the ISA/US Commissioner of Patents and Trademarks Box PCT Washington, D.C. 20231 Facsimile No. (703) 305-3230	Authorized officer DANIEL MOON Telephone No. (703) 308-1148 <i>Sheila Venev</i> Paralegal Specialist Technology Center 3700