

Nov. 11, 1969

R. L. GESSNER
BALANCING OF GAS PRESSURE FORCES IN MULTI-STAGE
REGENERATIVE COMPRESSORS

3,477,636

Filed April 4, 1968

2 Sheets-Sheet 1

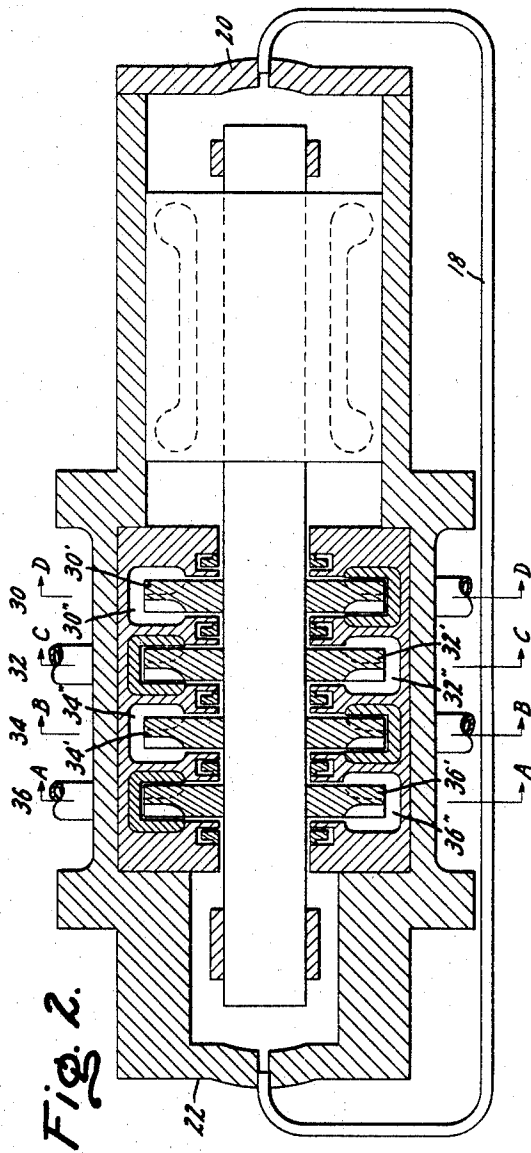
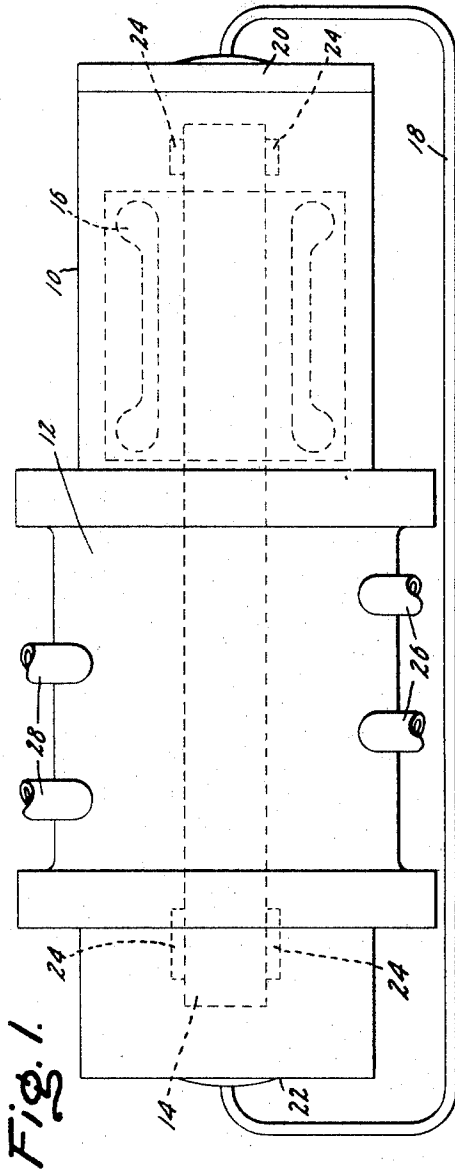

Inventor:
Robert L. Gessner,
by Paul G. Frank
His Attorney.

Nov. 11, 1969

R. L. GESSNER

3,477,636

BALANCING OF GAS PRESSURE FORCES IN MULTI-STAGE
REGENERATIVE COMPRESSORS

Filed April 4, 1968

2 Sheets-Sheet 2

Fig. 4.

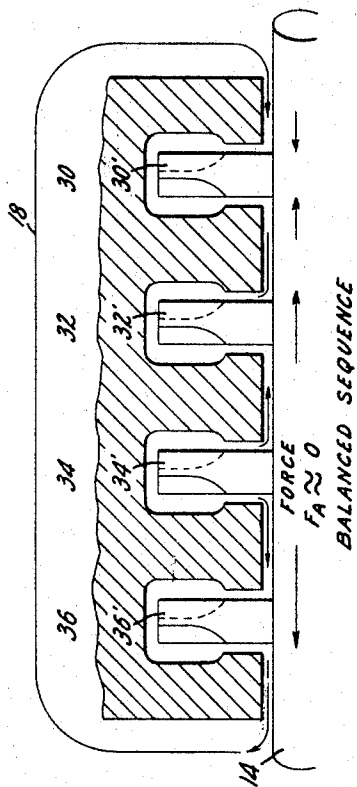

Fig. 3.

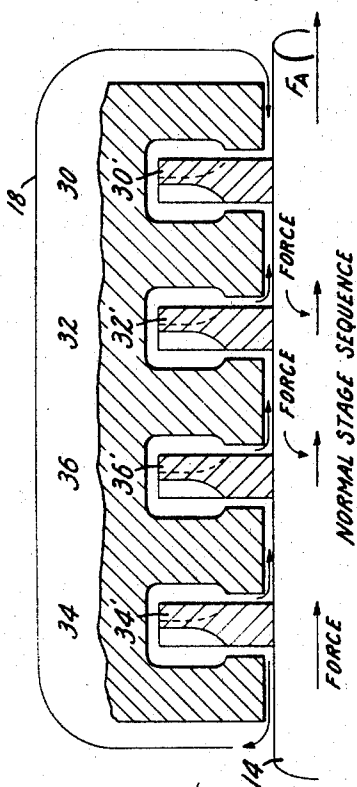
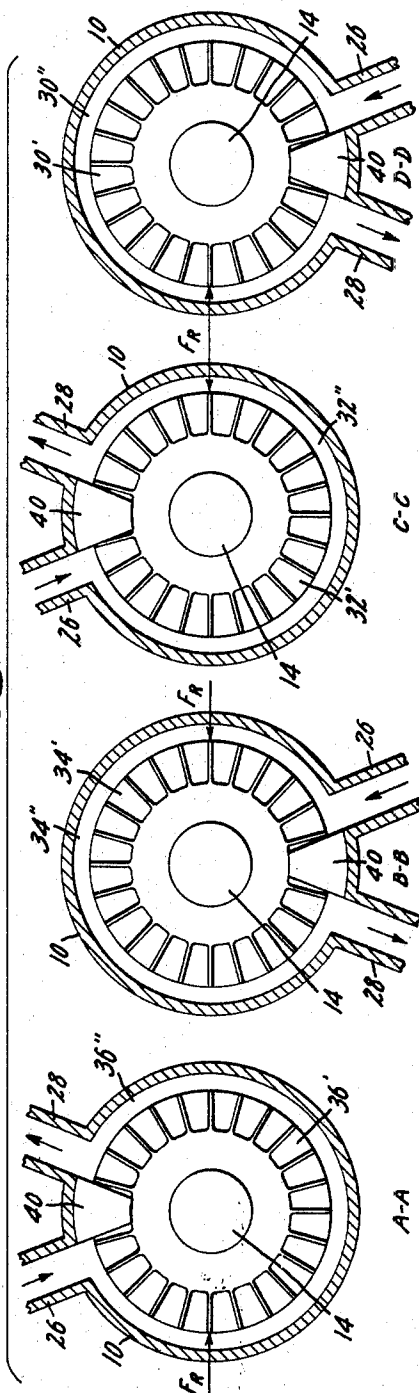

Fig. 5.



Inventor:
Robert L. Gessner,
by Paul A. Frank
His Attorney.

1

2

3,477,636

BALANCING OF GAS PRESSURE FORCES IN MULTI-STAGE REGENERATIVE COMPRESSORS

Robert L. Gessner, Ballston Lake, N.Y., assignor to General Electric Company, a corporation of New York

Filed Apr. 4, 1968, Ser. No. 718,829

Int. Cl. F04d 17/12, 29/66

U.S. Cl. 230-129

1 Claim

ABSTRACT OF THE DISCLOSURE

A stage and ducting arrangement for a multi-stage regenerative compressor which arrangement is used for approximately balancing the radial and axial forces caused by pressure distribution within the compressor. Also, the tendency to thermal distortion of the stationary parts is reduced. A stripper sector is disposed between the inlet and outlet of each stage of the compressor and each stripper sector is circumferentially positioned with respect to the stripper sectors of adjacent stages so that radial forces acting on that stage, due to the static pressure rise, oppose similar radial forces exerted on the adjacent stages. The said positioning also distributes the regions of low and high temperature in the stationary parts. The stages are axially positioned in a non-consecutive sequence from a low pressure end of the compressor shaft to a high pressure end so that the axial forces on the impellers of each stage, due to interstage leakage, are approximately offsetting. An external bypass conduit is provided between the ends of the compressor casing to equalize the thrust producing, interstage leakage pressure which accumulates at these points.

The invention relates to multi-stage gas compressors and, more specifically, to multi-stage, regenerative gas compressor stage and ducting arrangements whereby the radial and axial forces, due to pressure distribution within the compressor, are approximately balanced. The invention herein described was made in the course of or under a contract with the United States Department of the Air Force.

The need for a highly reliable, miniature, refrigerator with a long-life capability is well known. One of the major components in newer such refrigeration cycles is the multi-stage regenerative gas compressor with gas lubricated bearing rotor suspension driven by an integrally mounted electric motor. Such regenerative machines with conventional bearing systems have been successfully utilized in the liquid pumping industry for years because of their ability to produce a high head rise at low flow and rotation speeds. They are simple, reliable, and free from surge and stall instability. However, in multi-stage regenerative compressors problems arise with respect to unbalanced radial and axial pressure forces, and thermal distortion. Unbalanced pressure forces increase the loads on the bearings; thermal distortion increases the likelihood of stationary parts interfering with rotating parts, causing failure of the machine. Minimum bearing loads are desirable in machines with conventional bearings and are critical in gas bearing machinery because of inherently low bearing load capacity.

In a regenerative compressor stage, the static pressure rise, due to the impeller blading action, is approximately linear with circumferential position from inlet to outlet. The pressure rise, in turn, creates an unbalanced radial force vector which acts on the associated impeller at a point about 270°, in the direction of impeller rotation, from a stripper sector disposed between the inlet and outlet of the stage. Furthermore, a temperature rise accompanies the pressure rise in the gas so that there is, in

the stationary parts, a temperature increase approximately linear with circumferential position from the inlet to the outlet in the direction of impeller rotation. The resulting temperature gradient in the stationary parts causes differential thermal expansion with circumferential position. Such differential expansion causes thermal distortion which can adversely affect clearances and alignments within the machine. In addition to the unbalanced radial force problem, the difference in the pressure levels of the various stages of a multi-stage compressor gives rise to interstage leakage. Such leakage is received from a higher pressure stage on one side of a stage and is discharged to a lower pressure stage on the opposite side of the stage. This leakage then causes a pressure differential across the impeller of the stage, which pressure differential creates an unbalanced axial force operating as a function of the pressure differential and area of the impeller. If the stages are arranged in the order of increasing pressure in multi-stage compressors, the individual axial forces acting on each impeller are additive and create an unbalanced axial resultant force which must be countered by appropriate thrust bearings.

Since weight is a critical factor in many applications, it is necessary to use as small bearings and other components as possible. If the compressor stages and stripper sectors are not disposed essentially as disclosed herein, the gas bearings necessary to accommodate the unbalanced axial and radial forces created within the miniature refrigerator compressors have to be undesirably large and thereby present significant weight and design problems. Moreover, due to the unbalanced loading, gas bearing performance is acutely sensitive to compressor loading and the range of conditions for which the bearings must perform satisfactorily is unnecessarily broad. Consequently, the installation of bearings capable of meeting this broad range of requirements presents a problem of burdensome expense and weight.

Accordingly, it is one object of this invention to reduce the unbalanced radial and axial forces on the journal and thrust bearings of a multi-stage regenerative compressor to permit the use of smaller bearings.

It is another object of this invention to narrow the range of loadings within which compressor bearings must perform and thereby reduce the requirements on such bearings which reduction, in turn, permits the use of less expensive bearings.

It is a further object of this invention to reduce the problem of thermal distortion in compressor housings with respect to the clearances and alignments of the related internal moving members.

In carrying out this invention in the preferred form, an improved multi-stage regenerative compressor is provided having at least one stage interposed between stages of lower pressure so that the axial pressures due to interstage leakage are approximately offsetting. Each stage of the compressor is circumferentially arranged so that the radial force on that stage impeller, due to the static pressure rise within the stage, is applied to the impeller in a direction opposing any similar forces exerted on the impellers of adjacent stages. An additional benefit of this circumferential arrangement is that regions of high and low temperature in adjacent stages are distributed so as to reduce to a minimum the potential for thermal distortion. An external pressure bypass is provided which communicates the high pressure end of the compressor casing with the low pressure end, whereby the thrust pressures acting on either end of the compressor shaft due to interstage leakage, are equalized.

The specification concludes the claims which particularly point out and distinctly claim the invention which is sought to be protected and a preferred embodiment is

disclosed in the following detailed description in connection with the accompanying drawings in which:

FIGURE 1 shows an overall elevation view of a four-stage regenerative gas compressor with an integral electric motor.

FIGURE 2 shows a partial longitudinal sectional view of the four-stage compressor shown in FIGURE 1.

FIGURE 3 is a schematic drawing of a compressor with a normal stage sequence showing the additive axial forces which build due to interstage leakage.

FIGURE 4 is a schematic drawing of the compressor in FIGURE 1, showing the offsetting axial forces developed by the balanced sequence of stages disclosed in the preferred embodiment.

FIGURE 5 shows four cross-sectional views of the compressor in FIGURE 1 with one view taken at each of the stages. This figure shows the balance of radial forces achieved by the orientation of stripper sections in the preferred embodiment.

In the drawings in which like numerals are used to indicate like parts throughout the various views thereof, a preferred embodiment of this invention is shown in FIGURE 1 as a four-stage regenerative compressor comprising an outer housing 10, a compressor section 12, a rotatable shaft 14 and an integrally mounted electric motor 16 for driving the shaft 14.

The housing 10, which is of a generally cylindrical configuration, is constructed with an external bypass conduit 18 connecting housing ends 20 and 22 in gas pressure communication. It is through conduit 18 that any axial pressure differential established across the overall compressor section 12, due to interstage leakage, is dissipated as will be further explained later in this disclosure. Journal bearings 24 are provided to radially support shaft 14, which is electrically adapted at one end to form an armature for motor 16. An inlet 26 and an outlet 28 are formed at each of the stages of the compressor so as to project radially from the housing 10 and to ultimately interconnect with heat exchangers (not shown).

Referring now to FIGURE 2, the preferred embodiment is shown as a multi-stage compressor with four stages sequenced from right to left in the order of low pressure stage 30, low intermediate pressure stage 32, high pressure stage 34 and high intermediate pressure stage 36. It will be noticed that the sequence of stages is such, that at least one stage, stage 34, is disposed between two stages of lower pressure, stages 32 and 36. The use of this sequence insures that any pressure differential built up a cross the overall compressor section 12, due to interstage leakage, cannot produce a significant thrust force on the impellers 30', 32', 34' and 36'.

FIGURE 3 schematically demonstrates that, when a stage receives interstage leakage flow from a high pressure stage on one side and discharge leakage flow to a lower pressure stage on the opposite side, a pressure differential is established across the impeller of that stage. This pressure differential acts on the area of the impeller to produce an axial thrust and when the stages are arranged in normal sequence, as in FIGURE 3, these axial forces are additive and, thus, apply an unbalanced axial resultant force F_A to the shaft. With the sequence of stages of the preferred embodiment, as shown in FIGURE 4, however, the high pressure stage 34, acting in combination with the aforementioned external bypass 18, creates an opposing interstage leakage flow which tends to counter the interstage leakage through the remaining stages and to reduce the axial resultant force F_A to approximately zero. Interstage leakage is further restricted by the use of non-rubbing pressure seals 38, which are disposed on either side of each stage.

FIGURE 5 shows four cross-sectional views of the compressor in FIGURE 1 with one view taken at each stage. Section AA is taken of high intermediate pressure stage 36 which is substantially similar in construction to the remaining three stages. Stage 36 includes an impeller

36' which is mounted within a chamber 36'' by a heavy shrink fit on the shaft 14. Housing 10 is fitted with an inlet 26 and an outlet 28, which are connected with an associated inter-cooler (not shown). A stripper sector 40 is positioned within the chamber 36'' in the space between inlet 26 and outlet 28. This stripper sector 40 is generally U-shaped in cross-section and is so disposed within the chamber 36'' as to surround the impeller 36' with a slight clearance and to block the chamber in the sector between inlet 26 and outlet 28. In this manner, the stripper sector 40 provides a means for building pressure as gas is driven by impeller 36' from the inlet side of the stripper sector around the compressor chamber 36'' to the outlet side of stripper sector 40, at which point the desired pressure is created.

It has been found that the static pressure rise within chamber 36'' is nearly linear with circumferential position from inlet 26 to outlet 28 and that this pressure rise produces a radial force on impeller 36' which acts approximately 270° from the center line of stripper sector 40 in the direction of gas flow. This force F_R is an unbalancing vector which, when added to similar vectors acting on the remaining three stages, produces abnormal loading on journal bearings 24 of shaft 14. The invention, therefore, provides that the circumferential positioning of each stage, as shown in FIGURES 2 and 5, be such that the force F_R , of each stage is applied in a direction which opposes like forces acting on the adjacent stages and reduces the resultant radial force to approximately zero. By this circumferential stage arrangement, loadings on journal bearings 24 are balanced and, by the nonconsecutive sequence of the stages along the shaft, as shown in FIGURES 2 and 4 and discussed earlier in this disclosure, the abnormal loadings on the compressor's thrust bearings (not shown), due to interstage leakage, are offset.

It should be understood that, while there has been shown and described a particular embodiment of the invention, it will be obvious to those skilled in the art that various changes and modifications may be made without departing from the spirit and scope of the invention as set forth in the claims appended hereto.

What I claim as new and desire to secure by Letters Patent of the United States is:

1. A multi-stage regenerative compressor comprising: a casing; a compressor inlet; a compressor outlet; a rotatable shaft; means for driving said shaft; a first stage; a first stage inlet; said first stage inlet connected to said compressor inlet; a first stage outlet; a first stage stripper sector disposed between said first stage inlet and outlet; a second stage; said second stage being of higher pressure than said first stage; a second stage inlet; said second stage inlet being interconnected with said first stage outlet; a second stage outlet; a second stage stripper sector disposed between said second stage inlet and outlet; said second stage stripper sector being circumferentially positioned approximately 180° from said first stage stripper sector; a third stage; said third stage being of higher pressure than said first and second stages; a third stage inlet; said third stage inlet interconnected with said second stage outlet; a third stage outlet; a third stage stripper sector disposed between said third stage inlet and outlet; said third stage stripper sector being circumferentially positioned approximately 180° from said first stage stripper sector; a fourth stage; said fourth stage being of higher pressure than said first, second, and third stages; said fourth stage interposed between said second stage and said third stage; a fourth stage inlet; said fourth stage inlet interconnected with said third stage outlet; a fourth stage outlet; a fourth stage stripper sector disposed between said fourth stage inlet and fourth stage outlet; said fourth stage stripper sector circumferentially positioned approximately 180° from said third stage stripper sector; said fourth stage outlet connected to said compressor outlet; an external bypass pressure duct; said

5

external bypass duct constructed and adapted to connect a low pressure end of said compressor casing with a high pressure end of said casing; whereby the pressures at each end of said casing, due to interstage leakage, are approximately, equalized.

5

References Cited

UNITED STATES PATENTS

1,151,965	8/1915	Peterson	-----	103—112
1,979,621	11/1934	Hollander	-----	103—96
2,056,553	10/1936	Abramson	-----	103—108

10

6

2,340,787	2/1944	Zenner et al.	-----	103—112
2,455,460	12/1948	Zenner	-----	103—112
2,868,440	1/1959	McMahan	-----	230—130
3,171,353	3/1965	McMahan	-----	230—103

FOREIGN PATENTS

973,037	9/1950	France.
---------	--------	---------

HENRY F. RADUAZO, Primary Examiner

U.S. CI. X.R.

103—112; 230—125, 130, 132