



US 20140259790A1

(19) **United States**

(12) **Patent Application Publication**
FAGGIN et al.

(10) **Pub. No.: US 2014/0259790 A1**

(43) **Pub. Date: Sep. 18, 2014**

(54) **FOOTWEAR ARTICLE HAVING A TEMPERATURE REGULATION SYSTEM**

(52) **U.S. Cl.**
CPC *A43B 7/005* (2013.01)
USPC **36/103; 36/83**

(71) Applicant: **CROCS, INC.**, Niwot, CO (US)

(72) Inventors: **Luca FAGGIN**, Padova (IT); **Stefano FERNIANI**, Padova (IT)

(57) **ABSTRACT**

(21) Appl. No.: **14/213,708**

(22) Filed: **Mar. 14, 2014**

An article of footwear includes a body configured to receive a foot of a wearer of the article of footwear. A temperature regulation system is supported by the body. The temperature regulation system includes a reservoir containing a temperature regulating fluid configured to receive heat from the foot of the wearer. The reservoir is configured to be compressed between the foot of the wearer and the body to discharge the temperature regulating fluid from the reservoir. The temperature regulation system further includes a heat-dissipating portion receiving the temperature regulating fluid from the reservoir. The heat-dissipating portion is configured to permit the temperature regulating fluid to dissipate heat received from the foot of the wearer.

Related U.S. Application Data

(60) Provisional application No. 61/790,943, filed on Mar. 15, 2013.

Publication Classification

(51) **Int. Cl.**
A43B 7/00 (2006.01)

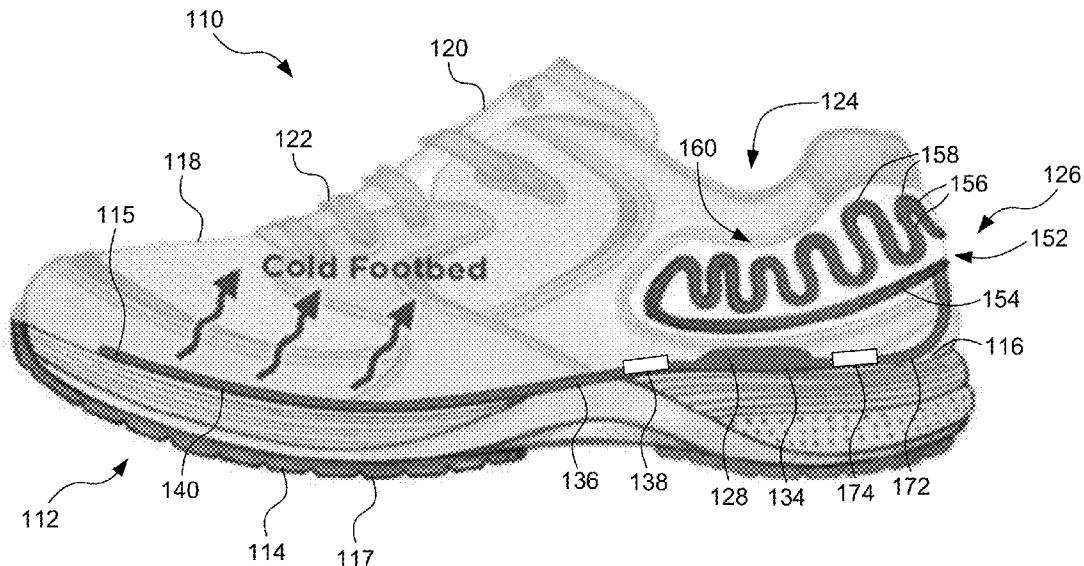

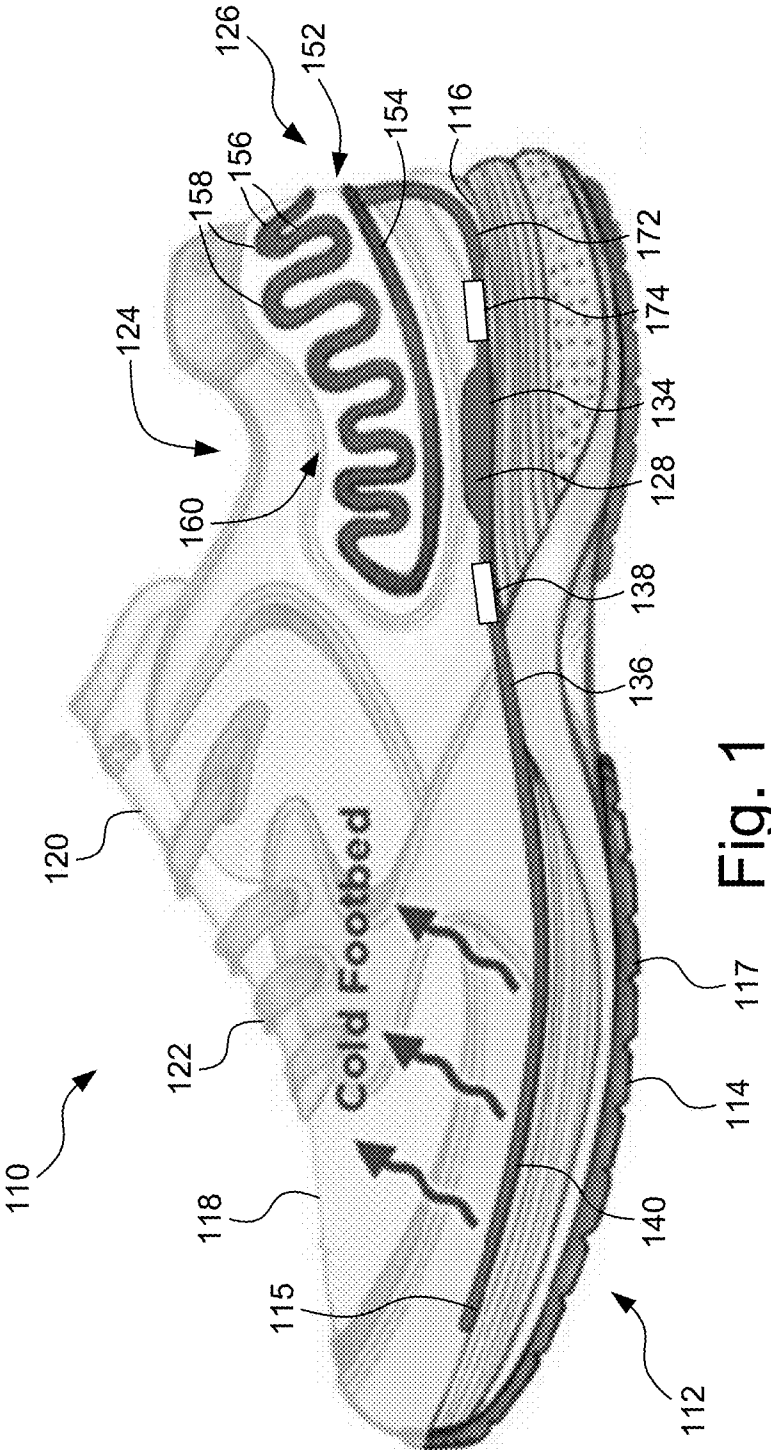

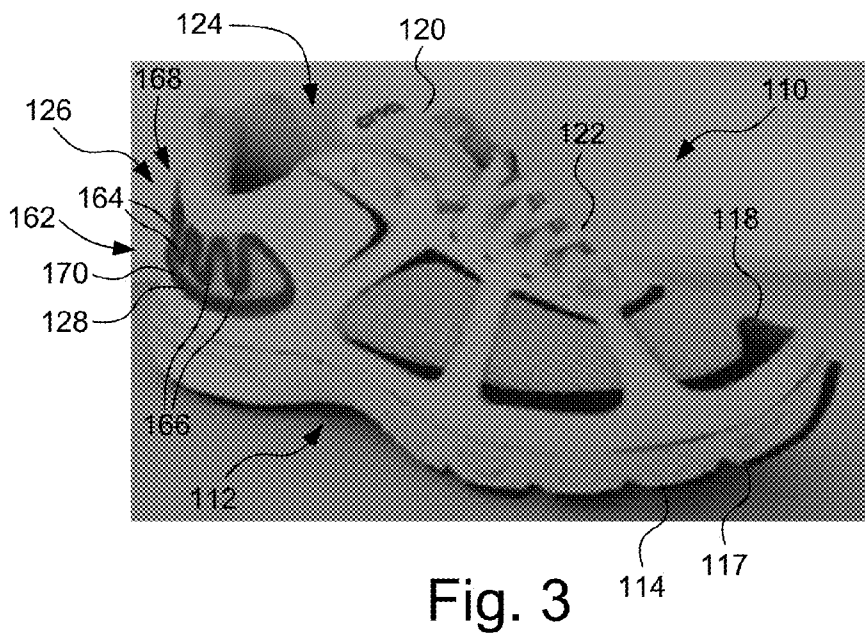
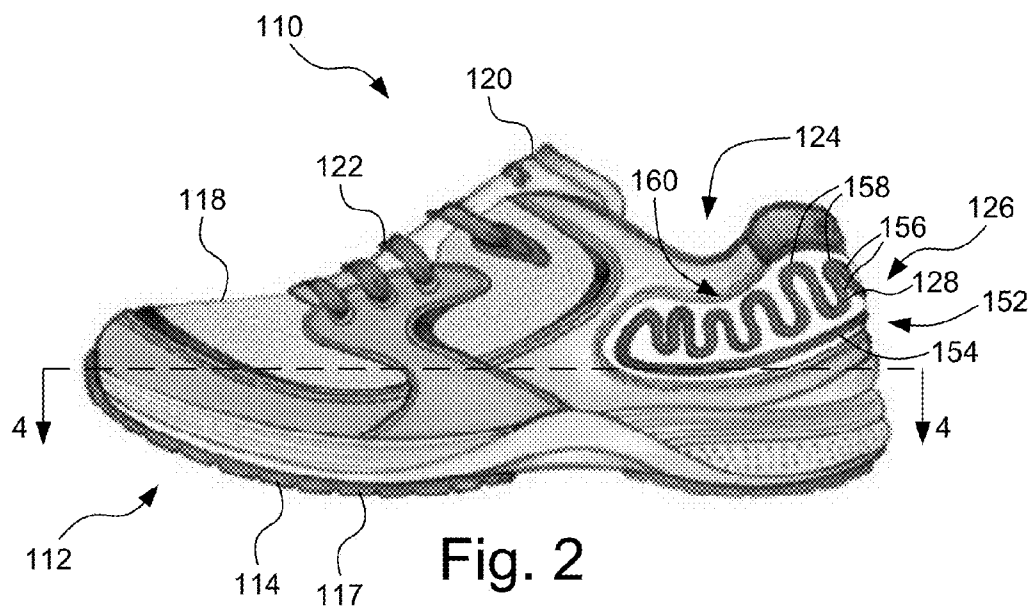

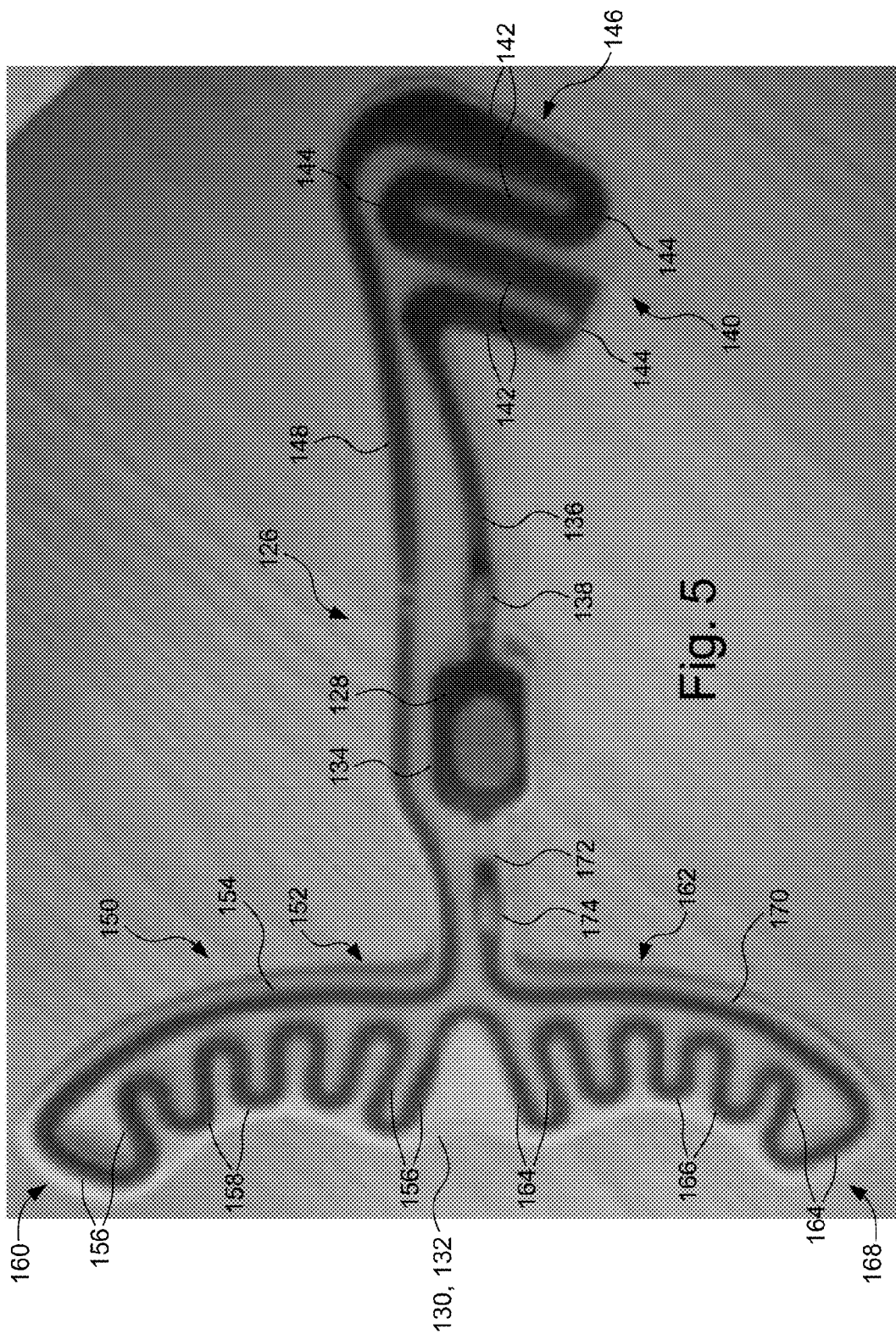

Fig. 5

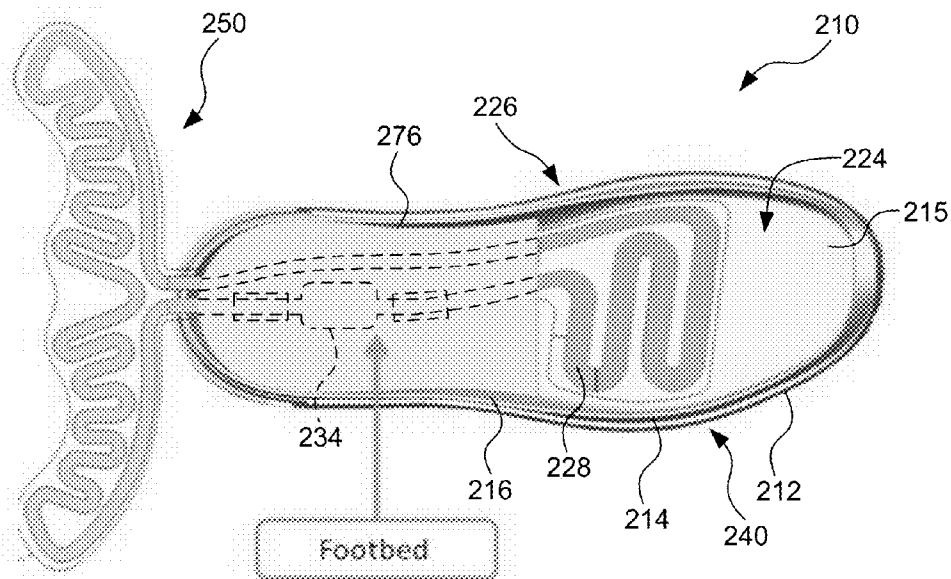

Fig. 6

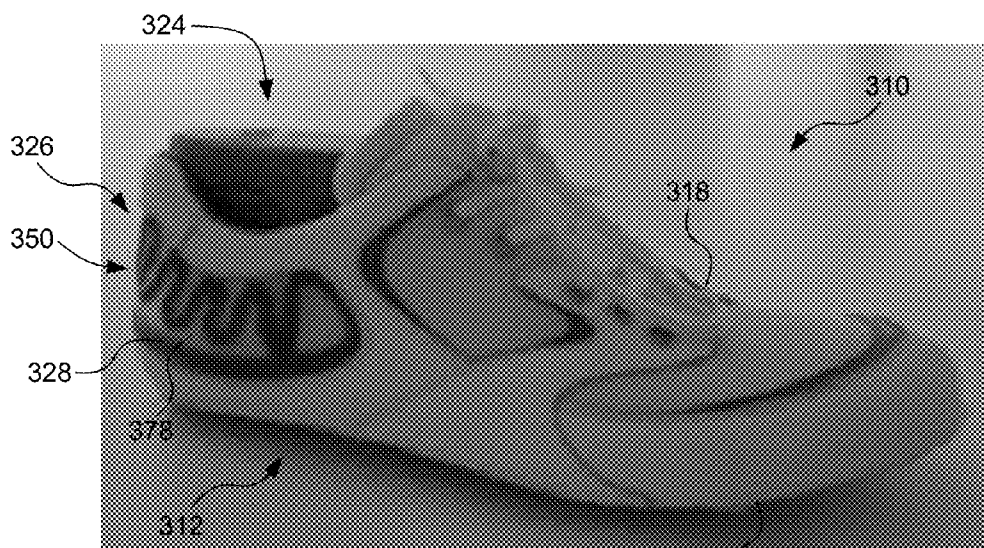

Fig. 7

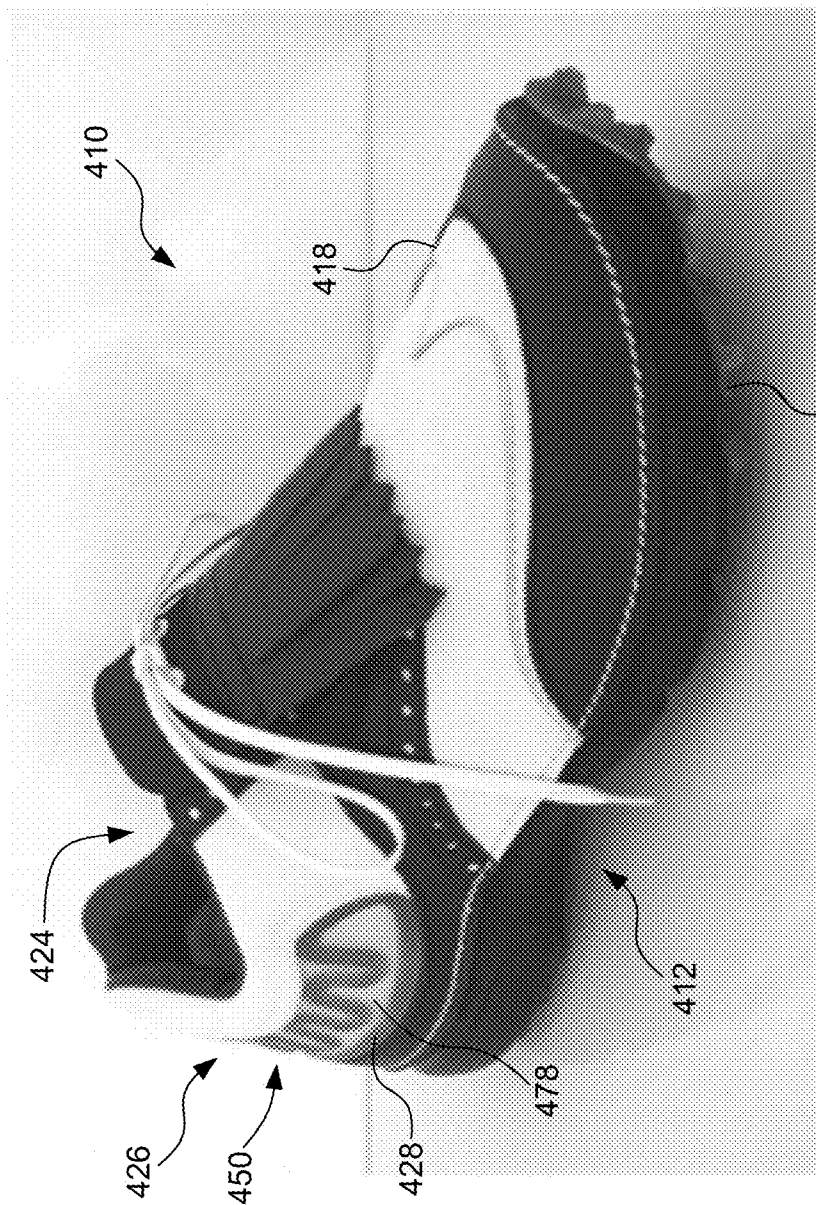

Fig. 8

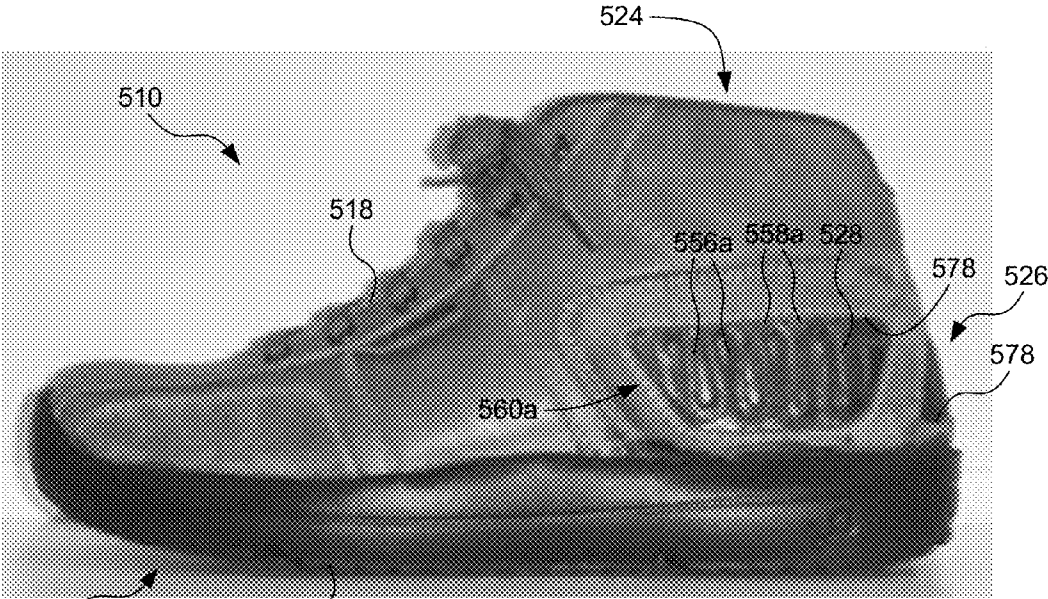

Fig. 9

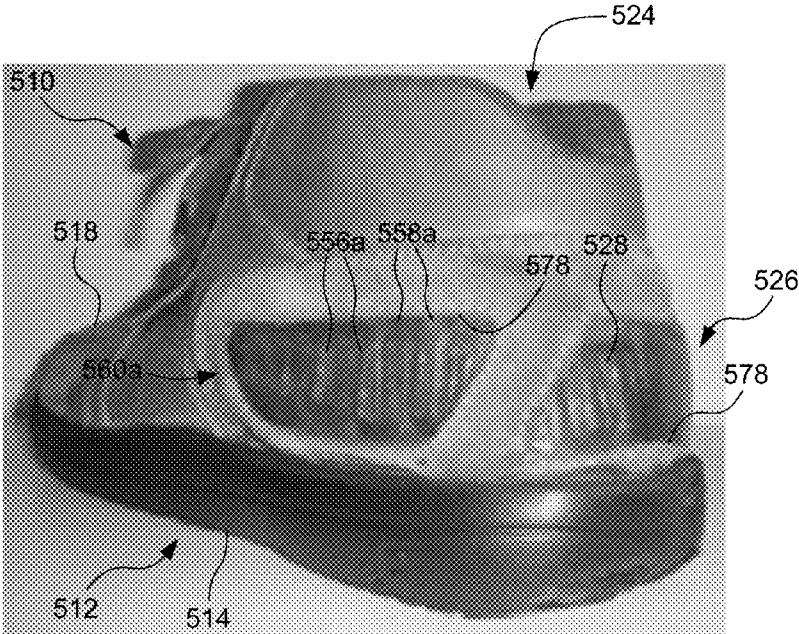

Fig. 10

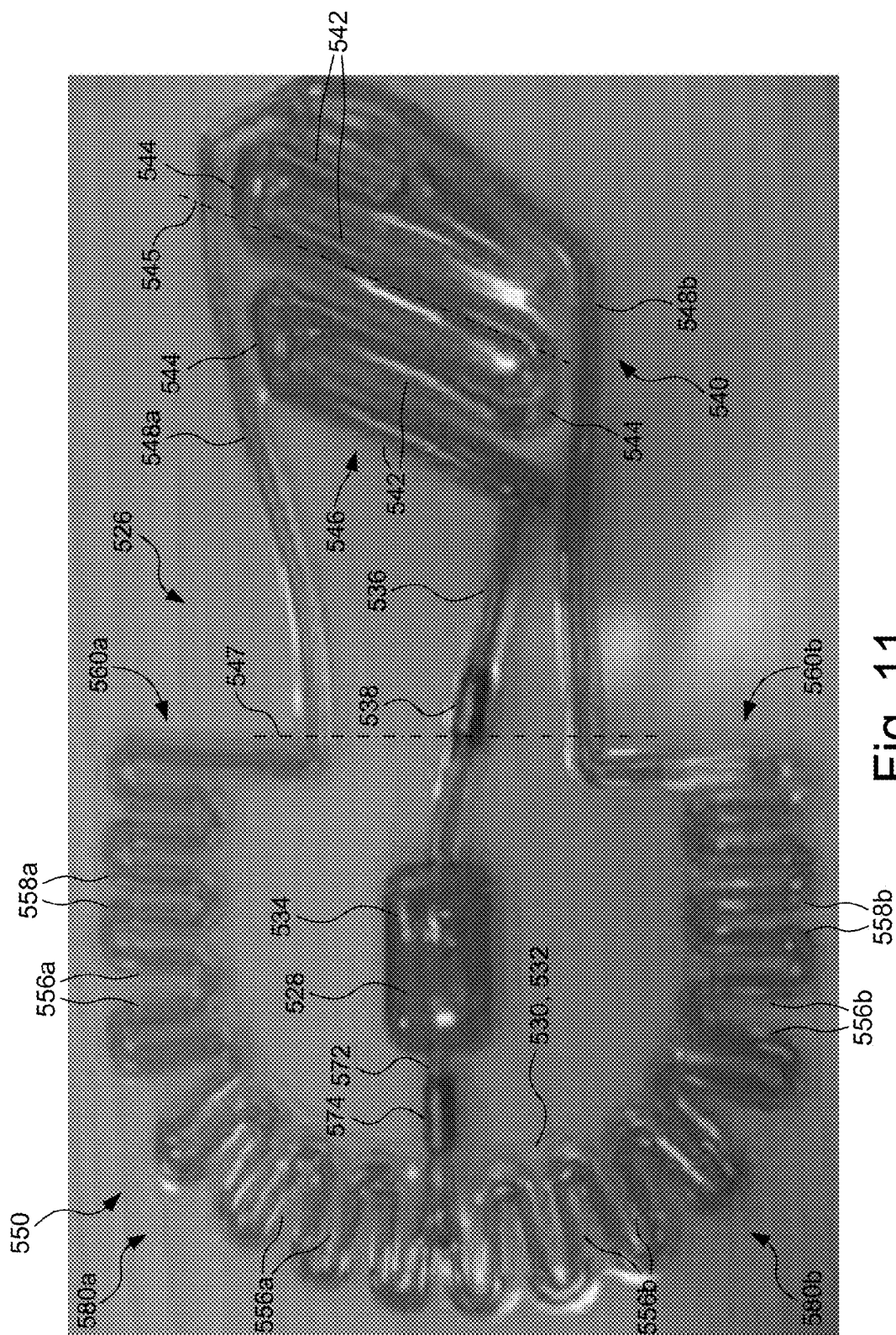

Fig. 11

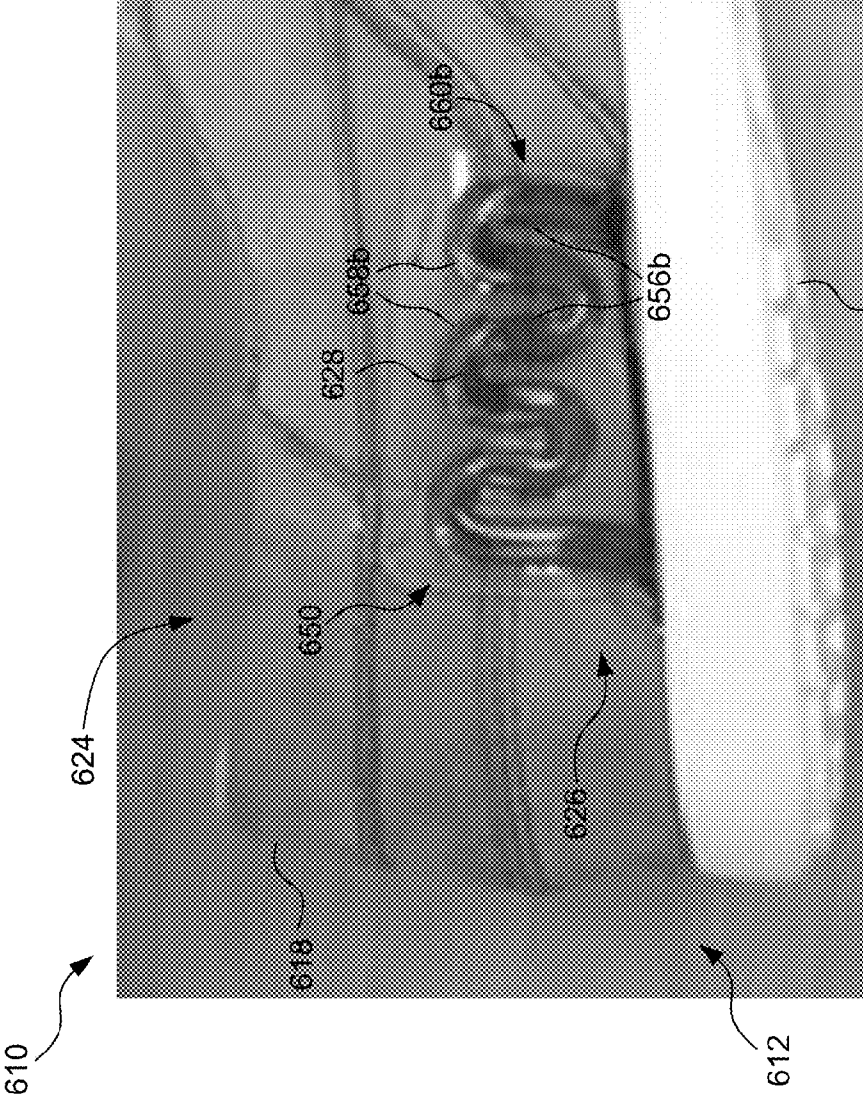

Fig. 14

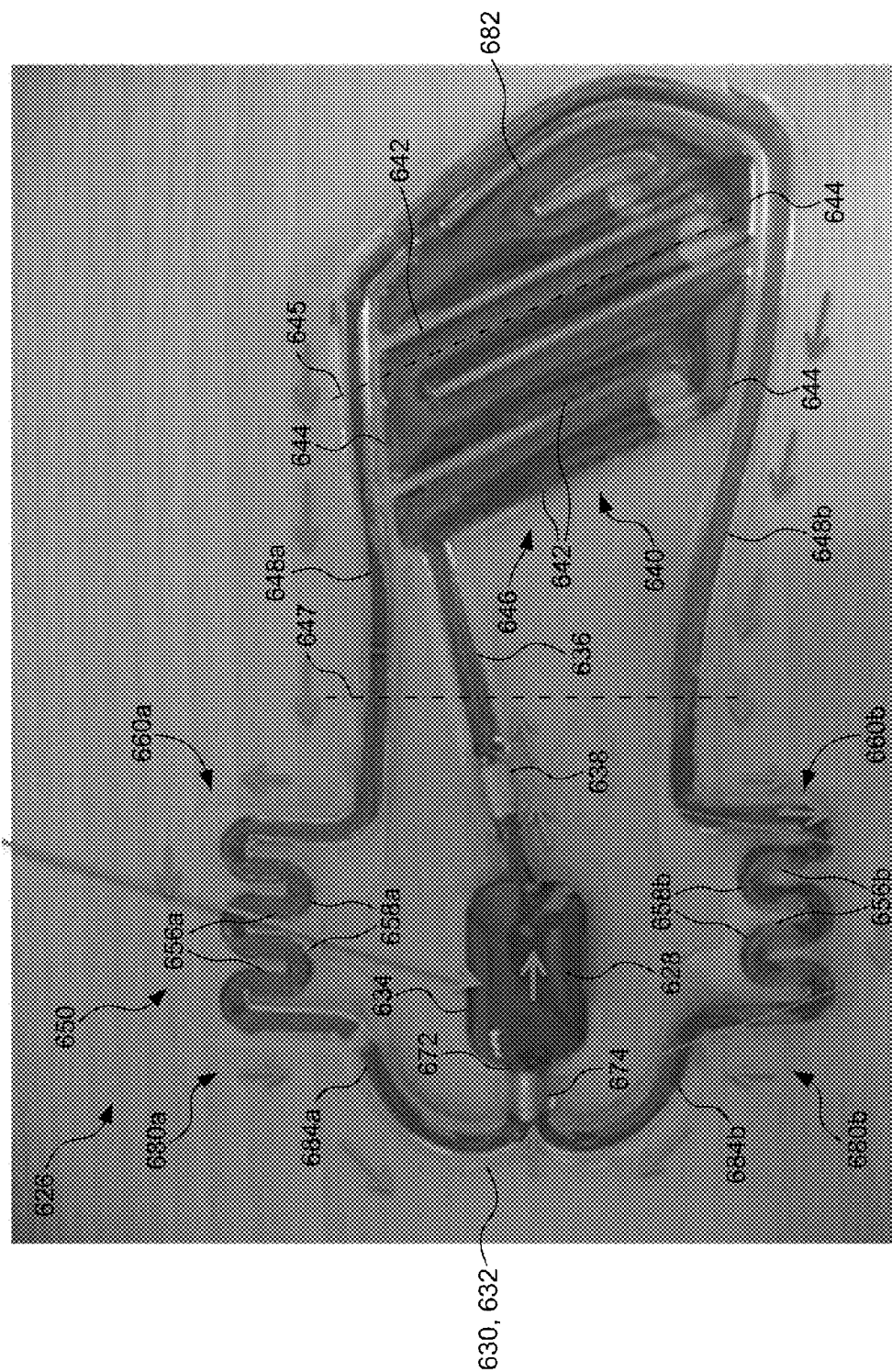

Fig. 15

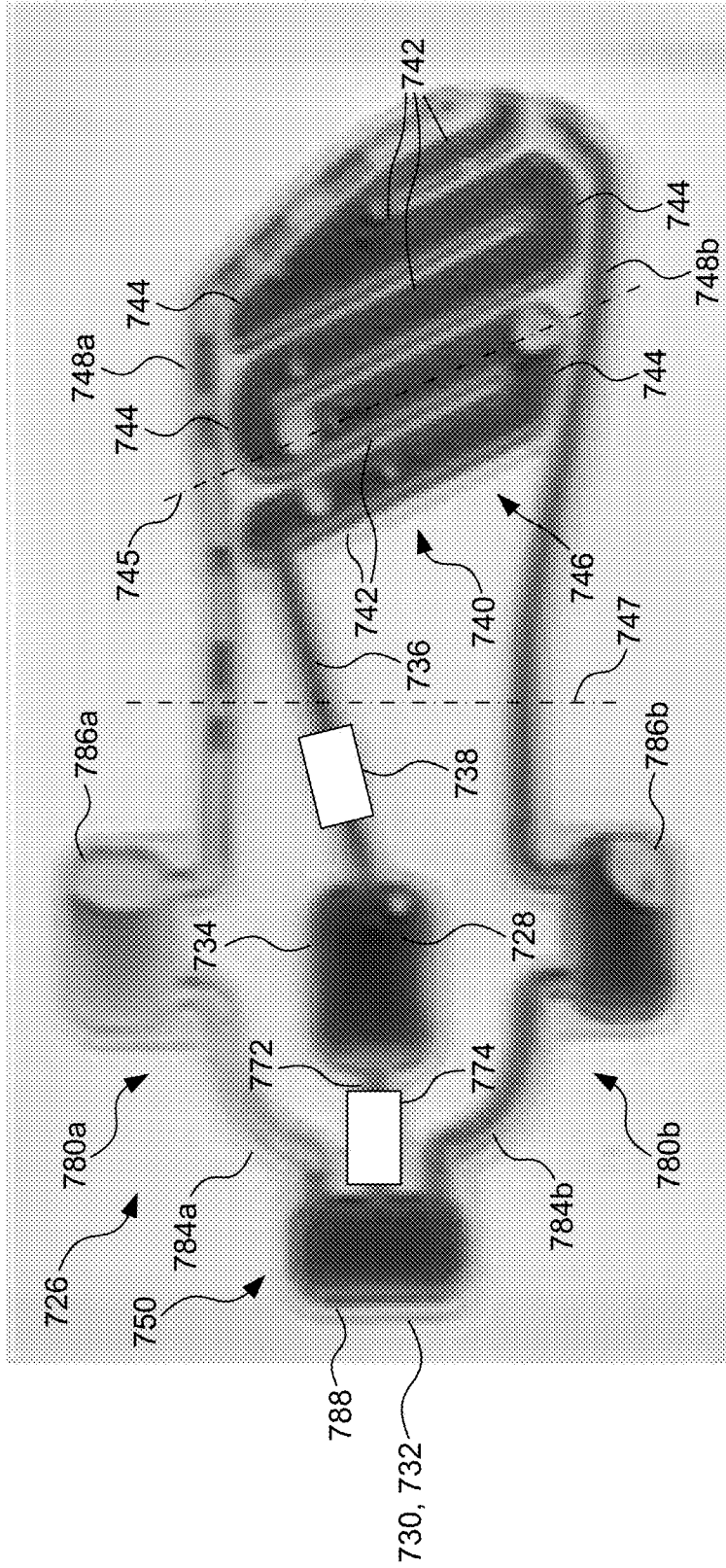

Fig. 16

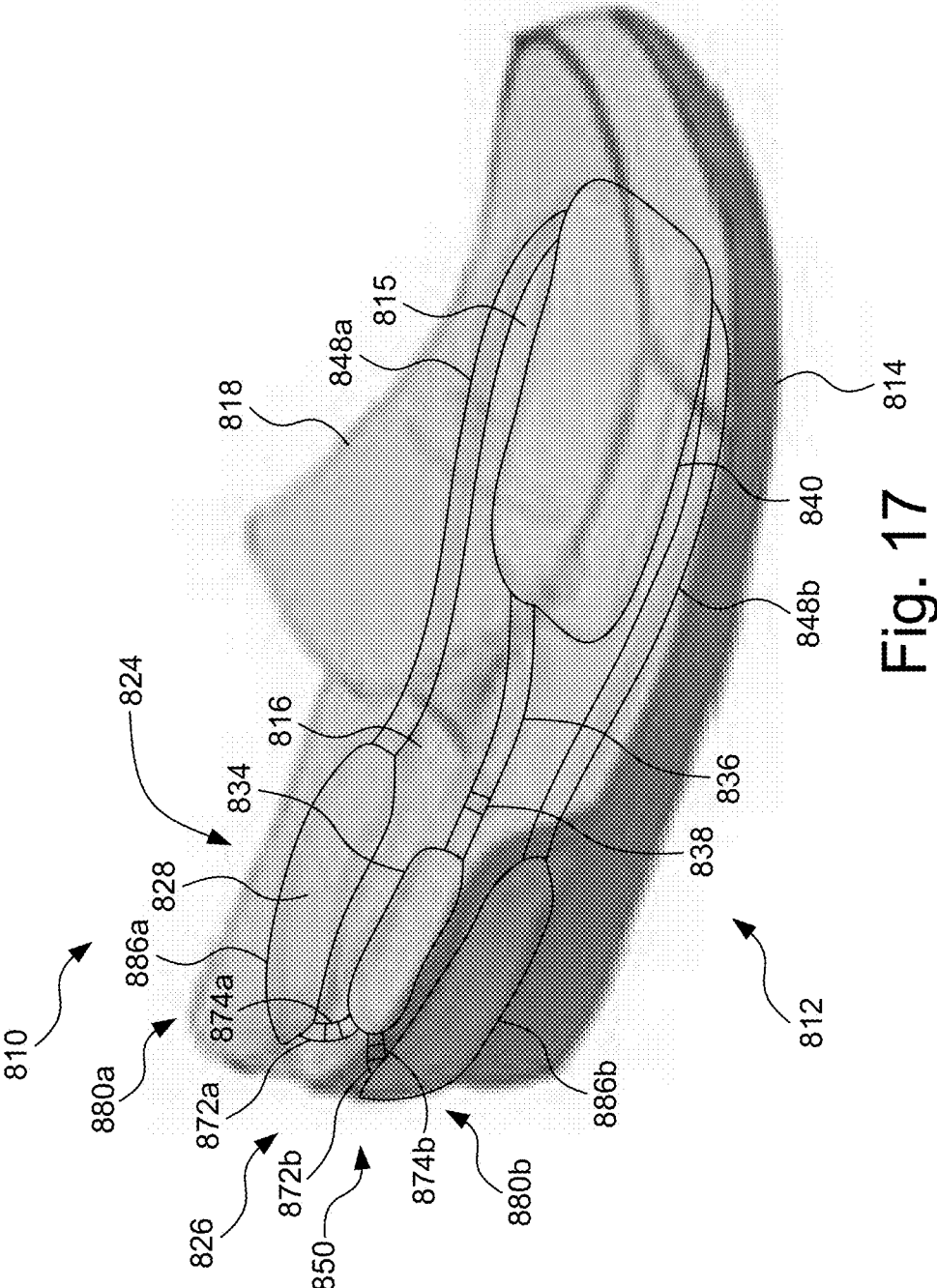

Fig. 17

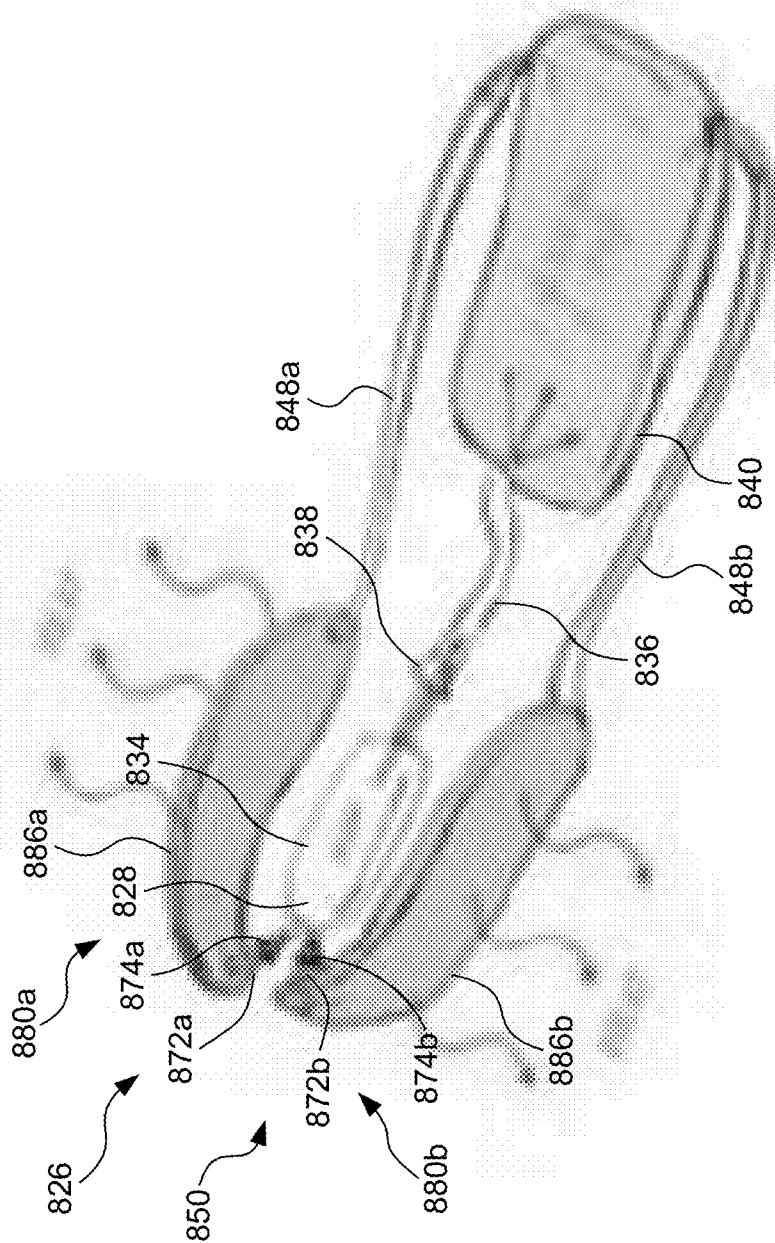

Fig. 18

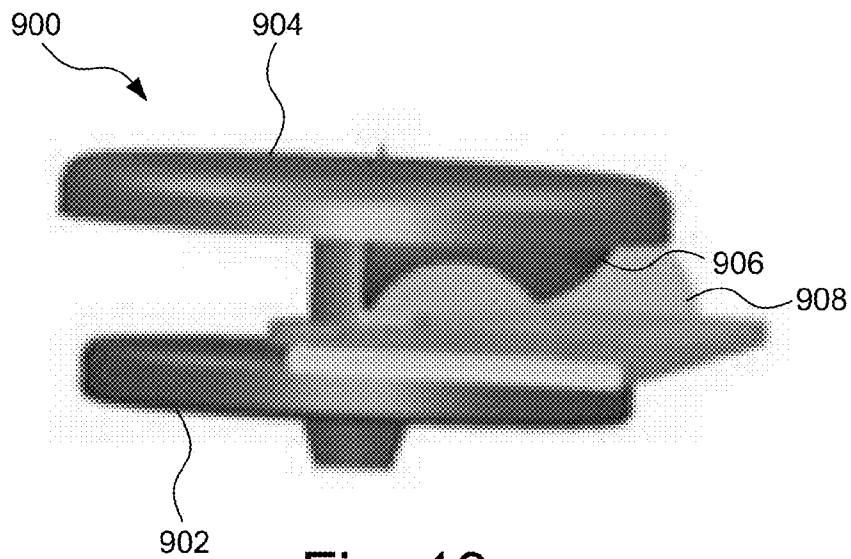

Fig. 19

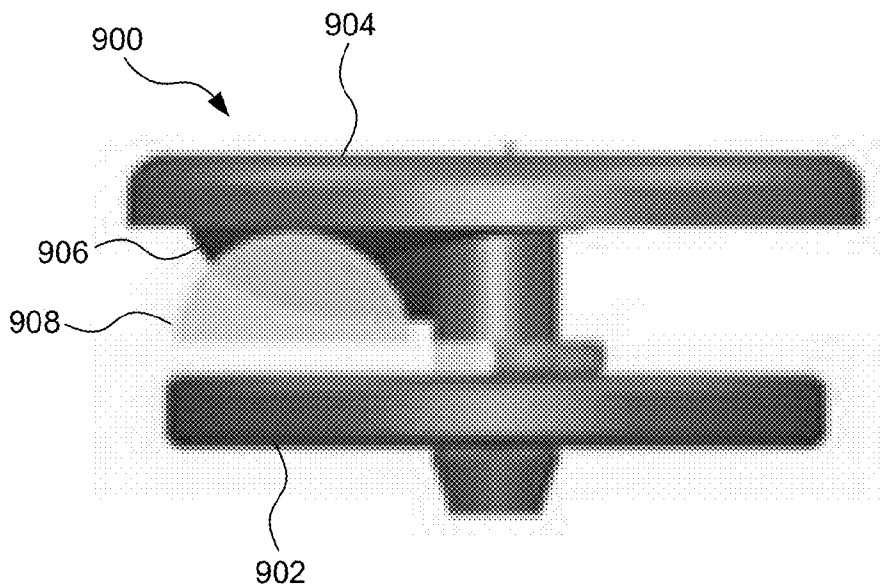

Fig. 20

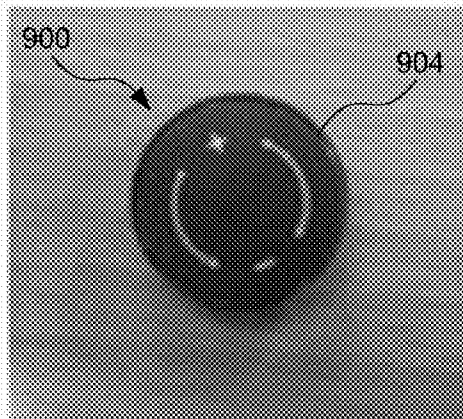

Fig. 21

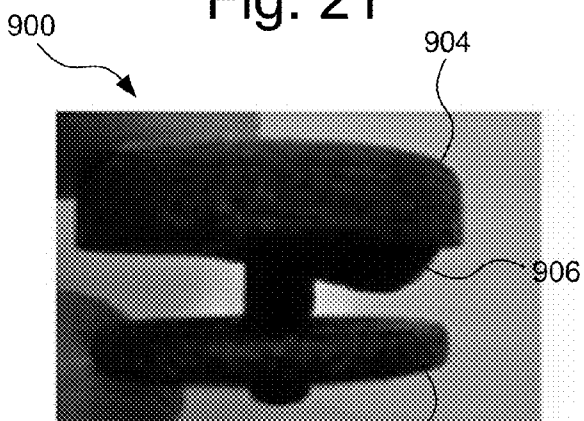

Fig. 22

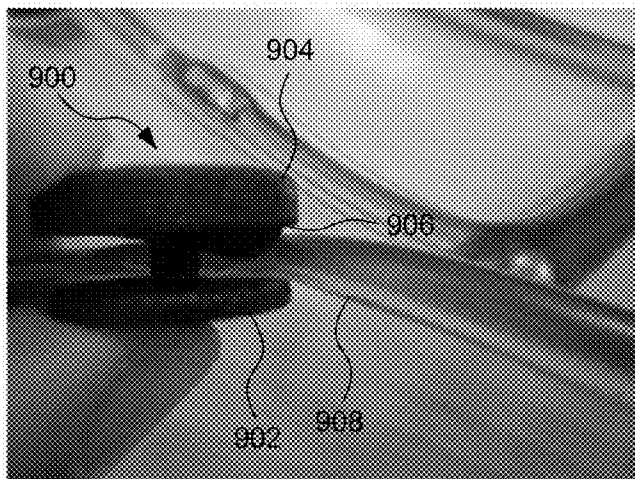

Fig. 23

FOOTWEAR ARTICLE HAVING A TEMPERATURE REGULATION SYSTEM

CROSS-REFERENCE TO RELATED APPLICATION

[0001] This application claims the benefit of U.S. Provisional Patent Application Ser. No. 61/790,943, filed on Mar. 15, 2013, which is incorporated by reference herein in its entirety for all purposes.

TECHNICAL FIELD

[0002] The present disclosure relates to an article of footwear, particularly an article of footwear including a system for regulating the temperature of the sole, the upper, and/or the interior chamber of the article.

BACKGROUND

[0003] Various types of articles of footwear include an interior chamber to receive the foot of the wearer. Such a chamber typically serves several purposes. For example, the chamber typically has a shape that is the inverse of the wearer's foot to facilitate securing the article to the wearer's foot. In addition, the chamber provides protection from adverse environmental conditions, such as precipitation, cold air, and the like. However, the internal chamber and adjacent portions of the article may become excessively warm due to environmental conditions and/or body heat generated by the wearer's foot. These conditions may lead to wearer discomfort or even pathologies such as tinea pedis (commonly referred to as "athlete's foot").

SUMMARY

[0004] An article of footwear according to embodiments of the present invention includes a body configured to receive a foot of a wearer of the article of footwear. A temperature regulation system is supported by the body. The temperature regulation system includes a reservoir containing a temperature regulating fluid configured to receive heat from the foot of the wearer. The reservoir is configured to be compressed between the foot of the wearer and the body to discharge the temperature regulating fluid from the reservoir. The temperature regulation system further includes a heat-dissipating portion receiving the temperature regulating fluid from the reservoir. The heat-dissipating portion is configured to permit the temperature regulating fluid to dissipate heat received from the foot of the wearer.

[0005] An article of footwear according to embodiments of the present invention includes a body defining a chamber configured to receive a foot of a wearer of the article of footwear. The article further includes a temperature regulation system supported by the body. The temperature regulation system contains a temperature regulating fluid configured to receive heat from the foot of the wearer. The temperature regulation system includes a plurality of passageway segments defining an endless circuit through which the temperature regulating fluid travels. The plurality of passageway segments define a heat-dissipating portion disposed outwardly of the chamber. The heat-dissipating portion is configured to permit the temperature regulating fluid to dissipate heat received from the foot of the wearer.

[0006] An article of footwear according to embodiments of the present invention includes a sole configured to support a foot of a wearer of the article of footwear. An upper is supported by the sole, and the upper and the sole together define

a chamber configured to receive the foot of the wearer. The article further includes a temperature regulation system containing a temperature regulating fluid configured to receive heat from the foot of the wearer. The temperature regulation system includes a reservoir supported by the sole and containing the temperature regulating fluid. The reservoir is configured to be compressed between the foot of the wearer and the sole to discharge the temperature regulating fluid from the reservoir. A heat-receiving portion is supported by the sole within the chamber and receives the temperature regulating fluid from the reservoir. The heat-receiving portion is configured to permit the temperature regulating fluid to receive heat from the foot of the wearer. A heat-dissipating portion is supported by the upper outside of the chamber. The heat-dissipating portion receives the temperature regulating fluid from the heat-receiving portion. The heat-dissipating portion is configured to permit the temperature regulating fluid to dissipate heat received from the foot of the wearer.

[0007] While multiple embodiments are disclosed, still other embodiments of the present invention will become apparent to those skilled in the art from the following detailed description, which shows and describes illustrative embodiments of the invention. Accordingly, the drawings and detailed description are to be regarded as illustrative in nature and not restrictive.

BRIEF DESCRIPTION OF THE DRAWINGS

[0008] FIG. 1 is a side view of an article of footwear in accordance with an embodiment of the present invention; an upper of the article of footwear is partially hidden to illustrate a temperature regulation system of the article of footwear;

[0009] FIG. 2 is a side view of the article of footwear of FIG. 1;

[0010] FIG. 3 is a perspective view of the article of footwear of FIG. 1;

[0011] FIG. 4 is a section view along line 4-4 of FIG. 2; a heat-dissipating portion of the temperature regulation system is separated from the upper of the article of footwear and disposed horizontally for illustrative purposes;

[0012] FIG. 5 is a top view of the temperature regulation system of the article of footwear of FIG. 1 separated from a body of the article of footwear;

[0013] FIG. 6 is a top section view of an article of footwear in accordance with an embodiment of the present invention; a heat-dissipating portion of the temperature regulation system is separated from the upper of the article of footwear and disposed horizontally for illustrative purposes;

[0014] FIG. 7 is a perspective view of an article of footwear in accordance with an embodiment of the present invention;

[0015] FIG. 8 is a perspective view of an article of footwear in accordance with an embodiment of the present invention;

[0016] FIG. 9 is a side view of an article of footwear in accordance with an embodiment of the present invention;

[0017] FIG. 10 is a perspective view of the article of footwear of FIG. 9;

[0018] FIG. 11 is a top view of a temperature regulation system of the article of footwear of FIG. 9 separated from a body of the article of footwear;

[0019] FIG. 12 is a partial top view of an article of footwear in accordance with an embodiment of the present invention;

[0020] FIG. 13 is a partial top view of the article of footwear of FIG. 12 including a footbed;

[0021] FIG. 14 is a partial side view of the article of footwear of FIG. 12;

[0022] FIG. 15 is a top view of a temperature regulation system of the article of footwear of FIG. 12 separated from a body of the article of footwear;

[0023] FIG. 16 is a top view of a temperature regulation system of an article of footwear in accordance with an embodiment of the present invention;

[0024] FIG. 17 is a perspective view of an article of footwear in accordance with an embodiment of the present invention; an upper of the article of footwear is partially hidden to illustrate a temperature regulation system of the article of footwear;

[0025] FIG. 18 is a perspective view of the temperature regulation system of the article of footwear of FIG. 17 separated from a body of the article of footwear;

[0026] FIG. 19 is a perspective view of a flow control element for a temperature regulation system in accordance with an embodiment of the present invention;

[0027] FIG. 20 is a side view of the flow control element of FIG. 19;

[0028] FIG. 21 is a top view of the flow control element of FIG. 19;

[0029] FIG. 22 is another side view of the flow control element of FIG. 19;

[0030] FIG. 23 is another perspective view of the flow control element of FIG. 19.

DETAILED DESCRIPTION

[0031] FIGS. 1-5 illustrate an article of footwear 110 in accordance with an embodiment of the present invention. The article of footwear 110 may be an athletic shoe including a body 112 configured to engage a foot of a wearer (not shown). The body 112 includes a sole 114 having an anteriorly-disposed forefoot-receiving portion 115 and a posteriorly-disposed heel-receiving portion 116. The sole 114 may comprise layers formed of various materials (for example, fabrics, polyurethane, rubber, combinations thereof, and the like). Such layers may define an outsole 117, a midsole (not shown), and an insole (not shown). The sole 114 connects to an upper 118 via a stitching (not shown), an adhesive (not shown), or the like. The upper 118 may comprise various materials (for example, various types of fabric and the like). The upper 118 defines a tongue 120 and supports adjacent to lacing 122. The upper 118 and the sole 114 together define an interior chamber 124 configured to receive the foot of the wearer. Article of footwear 110 may be, for example, a running shoe, a golf shoe, a walking shoe, a tennis shoe, a molded shoe, a casual shoe, a shoe with cleats, a show without cleats, a hiking boot, a ski boot, a roller skate shoe, a roller blade shoe, an ice skating shoe, or any other kind of shoe or footwear.

[0032] The body 112 mounts a temperature regulation system 126 that is partially disposed within the interior chamber 124. The temperature regulation system 126 contains a recirculating temperature regulating fluid 128, such as a mixture of water and glycerin, oils, or the like, that receives heat from the foot of the wearer. The temperature regulating fluid 128 may receive heat via direct thermal conduction between the foot of the wearer and the temperature regulation system 126, via indirect thermal conduction (such as through a sock worn by the wearer, between the foot of the wearer, the body 112, and ultimately the temperature regulation system 126, or the like), via thermal convection (such as between the foot of the wearer, the air within the chamber 124, and ultimately the temperature regulation system 126), combinations thereof,

and the like. The temperature regulating fluid 128 also dissipates heat to the environment of the article of footwear 110. Thus, the temperature regulation system 126 permits the body 112 and air within the chamber 124 to absorb and retain relatively little heat from the foot of the wearer compared to previous articles of footwear.

[0033] The temperature regulation system 126 may be generally formed by upper and lower fixedly-connected flexible sheets 130 and 132 (FIGS. 4 and 5). Such sheets 130 and 132 may comprise various materials, such as polyurethane or the like. The sheets 130 and 132 define various features that together form an endless passageway or circuit through which the temperature regulating fluid 128 travels.

[0034] The endless circuit is formed, in part, by a “pump” or deformable reservoir 134 that contains the temperature regulating fluid 128. The deformable reservoir 134 is supported by the heel-receiving portion 116 of the sole 114. Thus, when the wearer places his/her weight on the heel-receiving portion 116 of the sole 114 (for example, by taking a step, shifting his/her weight, or the like), the reservoir 134 is compressed between the foot of the wearer and the sole 114. This action causes the reservoir 134 to discharge at least some of the temperature regulating fluid 128 into a plurality of passageway segments that also form, in part, the endless circuit through which the temperature regulating fluid 128 travels. The reservoir 134 specifically discharges the temperature regulating fluid 128 to an anteriorly-extending outlet passageway segment 136.

[0035] The outlet passageway segment 136 includes a check or one-way valve 138. The check valve 138 permits the outlet passageway segment 136 to receive the temperature regulating fluid 128 from the reservoir 134. Conversely, the check valve 138 inhibits the reservoir 134 from receiving the temperature regulating fluid 128 directly from the outlet passageway segment 136. The check valve 138 may be any of various appropriate check valves, such as a miniature, one-direction valve including an internal spring-biased sphere or the like. The outlet passageway segment 136 also delivers the temperature regulating fluid 128 to an adjacent set of passageway segments that define a “cooler” or heat-receiving portion 140 of the temperature regulation system 126.

[0036] The heat-receiving portion 140 of the temperature regulation system 126 is supported by the forefoot-receiving portion 115 of the sole 114. Thus, the heat-receiving portion 140 receives heat from the forefoot of the wearer (via conduction and/or convection, as described above, or the like). The heat-receiving portion 140 includes several features that facilitate appropriate heat transfer from the forefoot of the wearer to the heat-receiving portion 140. In particular, the heat-receiving portion 140 includes a plurality of substantially parallel passageway segments 142 and connecting arcuate passageway segments 144. The heat-receiving portion 140 may include, for example, four or more passageway segments 142 and an appropriate number of connecting passageway segments 144. The passageway segments 142 and 144 together define a serpentine path or portion 146 of the endless circuit. Each of the passageway segments 142 and 144 may have a greater width, as viewed from above, than other passageway segments of the temperature regulation system 126. The passageway segments 142 may also extend along axes (see axis 145 of FIG. 4, for example) disposed at a relatively small acute angle (for example, 10 degrees or less) relative to a coronal plane 147 of the article of footwear 110.

[0037] The serpentine portion 146 of the endless circuit delivers the temperature regulating fluid 128 to a posteriorly-extending intermediate passageway segment 148. Together, the serpentine portion 146 and the intermediate passageway segment 148 provide the heat-receiving portion 140 with a width that may be 70 percent or more of the width of the forefoot-receiving portion 115 of the sole 114.

[0038] The intermediate passageway segment 148 extends through a gap between the sole 114 and the upper 118, through a passage extending through the upper 118, or the like. The intermediate passageway 148 delivers the temperature regulating fluid 128 to a “radiator” or heat-dissipating portion 150 (shown separated from the body 112 and disposed horizontally in FIG. 4 for illustrative purposes). As the name implies, the heat-dissipating portion 150 dissipates heat from the temperature regulating fluid 128 to the environment (via convection or the like). The heat-dissipating portion 150 may be disposed posteriorly relative to the reservoir 134 and, as shown in FIGS. 1-3, may also be supported by the upper 118 outside of the interior chamber 124. The heat-dissipating portion 150 may extend about portions of the upper 118 adjacent to the heel and ankle of the wearer.

[0039] The heat-dissipating portion 150 includes a first element 152 (see FIGS. 1, 2, 4, and 5) that receives the temperature regulating fluid 128 from the intermediate passageway segment 148. The first element 152 extends about portions of the upper 118 adjacent to the inner ankle of the wearer. The first element 152 includes an inferiorly-disposed passageway segment 154 that may arcuately extend in an inferior/superior direction. The passageway segment 154 delivers the temperature regulating fluid 128 to a plurality of superiorly-disposed passageway segments 156 (four of which are numbered in FIGS. 4 and 5) and connecting arcuate passageway segments 158 (two of which are numbered in FIGS. 4 and 5). The first element 152 may include, for example, ten or more passageway segments 156 and an appropriate number of connecting passageway segments 158. As most clearly shown in FIGS. 4 and 5, the passageway segments 156 may be offset from one another along an arc having a similar shape to the inferiorly-disposed passageway segment 154. The passageway segments 156 and 158 together define a serpentine path or portion 160 of the endless circuit.

[0040] The first element 152 delivers the temperature regulating fluid 128 to a second element 162 (see FIGS. 3-5). The second element 162 extends about portions of the upper 118 adjacent to the outer of the ankle of the wearer. In addition, the shape of the second element 162 may mirror that of the first element 152 over the sagittal plane 163 (see FIG. 4) of the article of footwear 110. That is, the second element 162 may include a plurality of superiorly-disposed passageway segments 164 (four of which are numbered in FIGS. 4 and 5) and connecting arcuate passageway segments 166 (two of which are numbered in FIGS. 4 and 5). The second element 162 may include, for example, ten or more passageway segments 164 and an appropriate number of connecting passageway segments 166. As most clearly shown in FIGS. 4 and 5, the passageway segments 164 may be offset from one another along an arc having a similar shape to an inferiorly-disposed passageway segment 170. The passageway segments 164 and 166 define a serpentine path or portion 168 of the endless circuit. The serpentine path 168 receives the temperature regulating fluid 128 from the serpentine path 160 of the first element 152.

[0041] The serpentine path 168 delivers the fluid 128 to the inferiorly-disposed passageway segment 170. The passageway segment 170 may arcuately extend in an inferior/superior direction. The passageway segment 170 delivers the temperature regulating fluid 128 to an anteriorly-extending reservoir inlet passageway segment 172.

[0042] The reservoir inlet passageway segment 172 extends through a gap between the sole 114 and the upper 118, through a passage extending through the upper 118, or the like. The reservoir inlet passageway segment 172 includes a check or one-way valve 174. The check valve 174 permits the reservoir 134 to receive the temperature regulating fluid 128 from the inlet passageway segment 172. Conversely, the check valve 174 inhibits the inlet passageway segment 172 from receiving the temperature regulating fluid 128 directly from the reservoir 134. The check valve 174 may be any of various appropriate check valves, such as those described above. The temperature regulating fluid 128 completes the endless circuit upon traveling from the inlet passageway segment 172 to the reservoir 134.

[0043] In some embodiments, at least some of the temperature regulating fluid 128 is disposed in each of the passageway segments and the reservoir 134 at all times. Further, each compression of the reservoir 134 displaces the temperature regulating fluid 128 along small portions of the endless circuit.

[0044] FIG. 6 illustrates an article of footwear 210 in accordance with an embodiment of the present invention. The article of footwear 210 includes a body 212 having a sole 214. The sole 214 includes an anteriorly-disposed forefoot-receiving portion 215 and a posteriorly-disposed heel-receiving portion 216. The sole 214 also connects to an upper (not shown). The upper and the sole 214 together define an interior chamber 224 configured to receive the foot of the wearer.

[0045] The body 212 mounts a temperature regulation system 226 that is as described above in connection with FIGS. 1-5. That is, the temperature regulation system 226 generally includes a deformable reservoir 234 that is supported by the heel-receiving portion 216 of the sole 214. The reservoir 234 is compressed between the foot of the wearer and the heel-receiving portion 216 of the sole 214 to deliver temperature regulating fluid 228 to a heat-receiving portion 240 supported by the forefoot-receiving portion 215 of the sole 214. The heat-receiving portion 240 delivers the temperature regulating fluid 228 to a heat-dissipating portion 250 supported by the upper outside of the interior chamber 224 (the heat-dissipating portion 250 is shown separated from the body 212 and disposed horizontally for illustrative purposes). The heat-dissipating portion 250 returns the temperature regulating fluid 228 to the reservoir 234.

[0046] In addition, the article of footwear 210 includes a footbed or “sock liner” 276 that may comprise various materials (for example, fabrics, polymers, combinations thereof, and the like). The footbed 276 is disposed within the interior chamber 224 and overlies the heel-receiving portion 216 of the sole 214 and the reservoir 234. Thus, the heel of the wearer compresses the reservoir 234 between the footbed 276 and the heel-receiving portion 216 of the sole 214 to drive the temperature regulating fluid 228 along the endless circuit. To facilitate heat transfer from the forefoot of the wearer, the footbed 276 does not overlie the forefoot-receiving portion 215 of the sole 214 and the heat-receiving portion 240.

[0047] In some embodiments, the footbed 276 may comprise one or more relatively thermally conductive materials

and overlie the heel-receiving portion 216 of the sole 214, the reservoir 234, the forefoot-receiving portion 215 of the sole 214, and the heat-receiving portion 240. In some embodiments, only a portion of the footbed 276 overlying the forefoot-receiving portion 215 of the sole 214 and the heat-receiving portion 240 comprises one or more relatively thermally conductive materials.

[0048] FIG. 7 illustrates an article of footwear 310 in accordance with an embodiment of the present invention. The article of footwear 310 may be a casual shoe including a body 312 configured to engage a foot of a wearer (not shown). The body 312 includes a sole 314 that connects to an upper 318. The upper 318 and the sole 314 together define an interior chamber 324 configured to receive the foot of the wearer.

[0049] The body 312 mounts a temperature regulation system 326 that is as described above in connection with FIGS. 1-5. That is, the temperature regulation system 326 generally includes a deformable reservoir (not shown) that is supported by a heel-receiving portion of the sole 314. The reservoir is compressed between the foot of the wearer and the heel-receiving portion of the sole 314 to deliver temperature regulating fluid 328 to a heat-receiving portion (not shown) supported by a forefoot-receiving portion of the sole 314. The heat-receiving portion delivers the temperature regulating fluid 328 to a heat-dissipating portion 350. The heat-dissipating portion 350 is disposed in an outwardly-facing recessed cavity 378 (that is, facing away from the interior chamber 324) defined by the upper 318. The heat-dissipating portion 350 returns the temperature regulating fluid 328 to the reservoir.

[0050] In some embodiments, the heat-dissipating portion 350 may be directly exposed to the environment. In some embodiments, the heat-dissipating portion 350 may be disposed in the cavity 378 and between the upper 318 and one or more relatively thermally conductive layers (not shown; such as polymer mesh layers and the like) lining the edge of the cavity 378.

[0051] FIG. 8 illustrates an article of footwear 410 in accordance with an embodiment of the present invention. The article of footwear 410 may be a golf shoe including a body 412 configured to engage a foot of a wearer (not shown). The body 412 includes a sole 414 that connects to an upper 418. The upper 418 and the sole 414 together define an interior chamber 424 configured to receive the foot of the wearer.

[0052] The body 412 mounts a temperature regulation system 426 that is as described above in connection with FIGS. 1-5. That is, the temperature regulation system 426 generally includes a deformable reservoir (not shown) that is supported by a heel-receiving portion of the sole 414. The reservoir is compressed between the foot of the wearer and the heel-receiving portion of the sole 414 to deliver temperature regulating fluid 428 to a heat-receiving portion (not shown) supported by a forefoot-receiving portion of the sole 414. The heat-receiving portion delivers the temperature regulating fluid 428 to a heat-dissipating portion 450. The heat-dissipating portion 450 is disposed in an outwardly-facing recessed cavity 478 (that is, facing away from the interior chamber 424) defined by the upper 418. The heat-dissipating portion 450 returns the temperature regulating fluid 428 to the reservoir.

[0053] FIGS. 9-11 illustrate an article of footwear 510 in accordance with an embodiment of the present invention. The article of footwear 510 may be a boot including a body 512 configured to engage a foot of a wearer (not shown). The body

512 includes a sole 514 having an anteriorly-disposed forefoot-receiving portion (not shown) and a posteriorly-disposed heel-receiving portion (not shown). The sole 514 connects to an upper 518, and the upper 518 and the sole 514 together define an interior chamber 524 configured to receive the foot of the wearer.

[0054] The body 512 mounts a temperature regulation system 526 that is partially disposed within the interior chamber 524. The temperature regulation system 526 contains a recirculating temperature regulating fluid 528 that receives heat from the foot of the wearer. The temperature regulating fluid 528 also dissipates heat to the environment of the article of footwear 510.

[0055] The temperature regulation system 526 may be generally formed by upper and lower fixedly-connected flexible sheets 530 and 532 (FIG. 11). The sheets 530 and 532 define various features that together form an endless passageway or circuit through which the temperature regulating fluid 528 travels.

[0056] The endless circuit is formed, in part, by a “pump” or deformable reservoir 534 that contains the temperature regulating fluid 528. The deformable reservoir 534 is supported by the heel-receiving portion of the sole 514. Thus, when the wearer places his/her weight on the heel-receiving portion of the sole 514 (for example, by taking a step, shifting his/her weight, or the like), the reservoir 534 is compressed between the foot of the wearer and the sole 514. This action causes the reservoir 534 to discharge at least some of the temperature regulating fluid 528 into a plurality of passageway segments that also form, in part, the endless circuit through which the temperature regulating fluid 528 travels. The reservoir 534 specifically discharges the temperature regulating fluid 528 to an anteriorly-extending outlet passageway segment 536.

[0057] The outlet passageway segment 536 includes a check or one-way valve 538. The check valve 538 permits the outlet passageway segment 536 to receive the temperature regulating fluid 528 from the reservoir 534. Conversely, the check valve 538 inhibits the reservoir 534 from receiving the temperature regulating fluid 528 directly from the outlet passageway segment 536. The outlet passageway segment 536 also delivers the temperature regulating fluid 528 to an adjacent set of passageway segments that define a “cooler” or heat-receiving portion 540 of the temperature regulation system 526.

[0058] The heat-receiving portion 540 of the temperature regulation system 526 is supported by the forefoot-receiving portion of the sole 514. Thus, the heat-receiving portion 540 receives heat from the forefoot of the wearer. The heat-receiving portion 540 includes several features that facilitate appropriate heat transfer from the forefoot of the wearer to the heat-receiving portion 540. In particular, the heat-receiving portion 540 includes a plurality of substantially parallel passageway segments 542 and connecting arcuate passageway segments 544. The heat-receiving portion 540 may include, for example, four or more passageway segments 542 and an appropriate number of connecting passageway segments 544. The passageway segments 542 and 544 together define a serpentine path or portion 546 of the endless circuit. Each of the passageway segments 542 and 544 may have a greater width, as viewed from above, than other passageway segments of the temperature regulation system 526. The passageway segments 542 may also extend along axes (see axis 545 of FIG. 11, for example) disposed at a relatively small acute

angle (for example, 10 degrees or less) relative to a coronal plane 547 of the article of footwear 510.

[0059] The serpentine portion 546 of the endless circuit delivers the temperature regulating fluid 528 to intermediate passageway segments 548a and 548b. The intermediate passageway segments 548a and 548b extend posteriorly from and on opposite sides of the serpentine portion 546 of the endless circuit. Together, the serpentine portion 546 and the intermediate passageway segments 548a and 548b provide the heat-receiving portion 540 with a width that may be 70 percent or more of the width of the forefoot-receiving portion of the sole 514.

[0060] The intermediate passageway segments 548a and 548b extend through gaps between the sole 514 and the upper 518, through passages extending through the upper 518, or the like. The intermediate passageway segments 548a and 548b deliver the temperature regulating fluid 528 to branches 580a and 580b, respectively, of a “radiator” or heat-dissipating portion 550. As the name implies, the heat-dissipating portion 550 dissipates heat from the temperature regulating fluid 528 to the environment. Overall, the heat-dissipating portion 550 may have a surface area that is three times that of the heat-receiving portion 540 or more. The heat-dissipating portion 550 may be disposed posteriorly relative to the reservoir 534 and, as shown in FIGS. 9 and 10, may also be supported by the upper 518 in outwardly-facing recessed cavities 578 (that is, facing away from the interior chamber 524). The heat-dissipating portion 550 may extend about portions of the upper 518 adjacent to the heel and ankle of the wearer.

[0061] The branches 580a and 580b of the heat-dissipating portion 550 include a plurality of passageway segments 556a and 556b, respectively, (four of each are numbered in FIG. 11) and connecting arcuate passageway segments 558a and 558b, respectively (two of each are numbered in FIG. 11). Each of the branches 580a and 580b may include, for example, sixteen or more passageway segments 556a and 556b, respectively, and an appropriate number of connecting passageway segments 558a and 558b, respectively. The passageway segments 556a and 558a together define a serpentine path or portion 560a of the endless circuit, and the passageway segments 556b and 558b together define a serpentine path or portion 560b of the endless circuit. The serpentine paths 560a and 560b deliver the fluid 528 to an anteriorly-extending reservoir inlet passageway segment 572.

[0062] The reservoir inlet passageway segment 572 extends through a gap between the sole 514 and the upper 518, through a passage extending through the upper 518, or the like. The reservoir inlet passageway segment 572 includes a check or one-way valve 574. The check valve 574 permits the reservoir 534 to receive the temperature regulating fluid 528 from the inlet passageway segment 572. Conversely, the check valve 574 inhibits the inlet passageway segment 572 from receiving the temperature regulating fluid 528 directly from the reservoir 534. The temperature regulating fluid 528 completes the endless circuit upon traveling from the inlet passageway segment 572 to the reservoir 534.

[0063] FIGS. 12-15 illustrate an article of footwear 610 in accordance with an embodiment of the present invention. The article of footwear 610 may be a casual shoe including a body 612 configured to engage a foot of a wearer (not shown). The body 612 includes a sole 614 having an anteriorly-disposed forefoot-receiving portion 615 and a posteriorly-disposed

heel-receiving portion 616. The sole 614 connects to an upper 618, and the upper 618 and the sole 614 together define an interior chamber 624 configured to receive the foot of the wearer.

[0064] The body 612 mounts a temperature regulation system 626 that is partially disposed within the interior chamber 624. The temperature regulation system 626 contains a recirculating temperature regulating fluid 628 that receives heat from the foot of the wearer. The temperature regulating fluid 628 also dissipates heat to the environment of the article of footwear 610.

[0065] The temperature regulation system 626 may be generally formed by upper and lower fixedly-connected flexible sheets 630 and 632 (FIG. 15). The sheets 630 and 632 define various features that together form an endless passageway or circuit through which the temperature regulating fluid 628 travels.

[0066] The endless circuit is formed, in part, by a “pump” or deformable reservoir 634 that contains the temperature regulating fluid 628. The deformable reservoir 634 is supported by the heel-receiving portion 616 of the sole 614. Thus, when the wearer places his/her weight on the heel-receiving portion 616 of the sole 614 (for example, by taking a step, shifting his/her weight, or the like), the reservoir 634 is compressed between the foot of the wearer and the sole 614. This action causes the reservoir 634 to discharge at least some of the temperature regulating fluid 628 into a plurality of passageway segments that also form, in part, the endless circuit through which the temperature regulating fluid 628 travels. The reservoir 634 specifically discharges the temperature regulating fluid 628 to an anteriorly-extending outlet passageway segment 636.

[0067] The outlet passageway segment 636 includes a check or one-way valve 638. The check valve 638 permits the outlet passageway segment 636 to receive the temperature regulating fluid 628 from the reservoir 634. Conversely, the check valve 638 inhibits the reservoir 634 from receiving the temperature regulating fluid 628 directly from the outlet passageway segment 636. The outlet passageway segment 636 also delivers the temperature regulating fluid 628 to an adjacent set of passageway segments that define a “cooler” or heat-receiving portion 640 of the temperature regulation system 626.

[0068] The heat-receiving portion 640 of the temperature regulation system 626 is supported by the forefoot-receiving portion 615 of the sole 614. Thus, the heat-receiving portion 640 receives heat from the forefoot of the wearer. The heat-receiving portion 640 includes several features that facilitate appropriate heat transfer from the forefoot of the wearer to the heat-receiving portion 640. In particular, the heat-receiving portion 640 includes a plurality of substantially parallel passageway segments 642 and connecting passageway segments 644. The heat-receiving portion 640 may include, for example, three or more passageway segments 642 and an appropriate number of connecting passageway segments 644. The passageway segments 642 and 644 together define a serpentine path or portion 646 of the endless circuit. Each of the passageway segments 642 and 644 may have a greater width, as viewed from above, than other passageway segments of the temperature regulation system 626. The passageway segments 642 may also extend along axes (see axis 645 of FIG. 15, for example) disposed at a relatively small acute angle (for example, 10 degrees or less) relative to a coronal plane 647 of the article of footwear 610.

[0069] The serpentine portion **646** of the endless circuit delivers the temperature regulating fluid **628** to an elongated loop passageway segment **682**. The elongated loop passageway segment **682** may generally extend along an axis parallel to that of the passageway segments **642**. In addition, the temperature regulating fluid **628** may circulate about the elongated loop passageway segment **682** before being delivered to intermediate passageway segments **648a** and **648b**.

[0070] The intermediate passageway segments **648a** and **648b** extend posteriorly from and on opposite sides of the serpentine portion **646** of the endless circuit. Together, the serpentine portion **646**, the elongated loop passageway segment **682**, and the intermediate passageway segments **648a** and **648b** provide the heat-receiving portion **640** with a width that may be 70 percent or more of the width of the forefoot-receiving portion **615** of the sole **614**.

[0071] The intermediate passageway segments **648a** and **648b** extend through gaps between the sole **614** and the upper **618**, through passages extending through the upper **618**, or the like. The intermediate passageway segments **648a** and **648b** deliver the temperature regulating fluid **628** to branches **680a** and **680b**, respectively, of a “radiator” or heat-dissipating portion **650**. As the name implies, the heat-dissipating portion **650** dissipates heat from the temperature regulating fluid **628** to the environment. The heat-dissipating portion **650** may be disposed generally evenly relative to the reservoir **634** in an anterior/posterior direction and, as shown in FIG. 14, may also be supported by the upper **618** outside of the interior chamber **624**. The heat-dissipating portion **650** may be supported by portions of the upper **618** on opposite sides of the ankle of the wearer.

[0072] The branches **680a** and **680b** of the heat-dissipating portion **650** include a plurality of passageway segments **656a** and **656b**, respectively, (two of each are numbered in FIG. 15) and connecting arcuate passageway segments **658a** and **658b**, respectively (two of each are numbered in FIG. 15). Each of the branches **680a** and **680b** may include, for example, six or more passageway segments **656a** and **656b**, respectively, and an appropriate number of connecting passageway segments **658a** and **658b**, respectively. The passageway segments **656a** and **658a** together define a serpentine path or portion **660a** of the endless circuit, and the passageway segments **656b** and **658b** together define a serpentine path or portion **660b** of the endless circuit. The serpentine paths **660a** and **660b** deliver the fluid **628** to intermediate passageway segments **684a** and **684b**, respectively. The intermediate passageway segments **684a** and **684b** extend through gaps between the sole **614** and the upper **618**, through passages extending through the upper **618**, or the like. The intermediate passageway segments **684a** and **684b** deliver the fluid **628** to an anteriorly-extending reservoir inlet passageway segment **672**.

[0073] The reservoir inlet passageway segment **672** includes a check or one-way valve **674**. The check valve **674** permits the reservoir **634** to receive the temperature regulating fluid **628** from the inlet passageway segment **672**. Conversely, the check valve **674** inhibits the inlet passageway segment **672** from receiving the temperature regulating fluid **628** directly from the reservoir **634**. The temperature regulating fluid **628** completes the endless circuit upon traveling from the inlet passageway segment **672** to the reservoir **634**.

[0074] In some embodiments, the article of footwear **610** may include a footbed **676** overlying the heel-receiving portion **616** of the sole **614** and the reservoir **634** (see FIG. 13). The footbed **676** may be disposed to the side of (that is, not

overlie) the forefoot-receiving portion **615** and the heat-receiving portion **640**. In some embodiments, the footbed **676** may be omitted (see FIG. 12).

[0075] FIG. 16 illustrates a temperature regulation system **726** that may be supported by the body of an article of footwear (not shown) in accordance with an embodiment of the present invention. The temperature regulation system **726** contains a recirculating temperature regulating fluid **728** that receives heat from the foot of the wearer. The temperature regulating fluid **728** also dissipates heat to the environment of the article of footwear.

[0076] The temperature regulation system **726** may be generally formed by upper and lower fixedly-connected flexible sheets **730** and **732**. The sheets **730** and **732** define various features that together form an endless passageway or circuit through which the temperature regulating fluid **728** travels.

[0077] The endless circuit is formed, in part, by a “pump” or deformable reservoir **734** that contains the temperature regulating fluid **728**. The deformable reservoir **734** is supported by the heel-receiving portion of the sole (not shown) of the article of footwear. Thus, when the wearer places his/her weight on the heel-receiving portion of the sole (for example, by taking a step, shifting his/her weight, or the like), the reservoir **734** is compressed between the foot of the wearer and the sole. This action causes the reservoir **734** to discharge at least some of the temperature regulating fluid **728** into a plurality of passageway segments that also form, in part, the endless circuit through which the temperature regulating fluid **728** travels. The reservoir **734** specifically discharges the temperature regulating fluid **728** to an anteriorly-extending outlet passageway segment **736**.

[0078] The outlet passageway segment **736** includes a check or one-way valve **738**. The check valve **738** permits the outlet passageway segment **736** to receive the temperature regulating fluid **728** from the reservoir **734**. Conversely, the check valve **738** inhibits the reservoir **734** from receiving the temperature regulating fluid **728** directly from the outlet passageway segment **736**. The outlet passageway segment **736** also delivers the temperature regulating fluid **728** to an adjacent set of passageway segments that define a “cooler” or heat-receiving portion **740** of the temperature regulation system **726**.

[0079] The heat-receiving portion **740** of the temperature regulation system **726** is supported by the forefoot-receiving portion of the sole (not shown) of the article of footwear. Thus, the heat-receiving portion **740** receives heat from the forefoot of the wearer. The heat-receiving portion **740** includes several features that facilitate appropriate heat transfer from the forefoot of the wearer to the heat-receiving portion **740**. In particular, the heat-receiving portion **740** includes a plurality of substantially parallel passageway segments **742** and connecting passageway segments **744**. The heat-receiving portion **740** may include, for example, five or more passageway segments **742** and an appropriate number of connecting passageway segments **744**. The passageway segments **742** and **744** together define a serpentine path or portion **746** of the endless circuit. Each of the passageway segments **742** and **744** may have a greater width, as viewed from above, than other passageway segments of the temperature regulation system **726**. The passageway segments **742** may also extend along axes (see axis **745**, for example) disposed at a relatively small acute angle (for example, 10 degrees or less) relative to a coronal plane **747** of the article of footwear. The serpentine portion **746** of the endless circuit

delivers the temperature regulating fluid **728** to intermediate passageway segments **748a** and **748b**.

[0080] The intermediate passageway segments **748a** and **748b** extend posteriorly from and on opposite sides of the serpentine portion **746** of the endless circuit. Together, the serpentine portion **746** and the intermediate passageway segments **748a** and **748b** provide the heat-receiving portion **740** with a width that may be 70 percent or more of the width of the forefoot-receiving portion of the sole.

[0081] The intermediate passageway segments **748a** and **748b** deliver the temperature regulating fluid **728** to branches **780a** and **780b**, respectively, of a “radiator” or heat-dissipating portion **750**. As the name implies, the heat-dissipating portion **750** dissipates heat from the temperature regulating fluid **728** to the environment. The heat-dissipating portion **750** may be disposed generally evenly relative to the reservoir **734** in an anterior/posterior direction and may also be supported by an upper of the article of footwear (not shown) outside of an interior foot-receiving chamber. The heat-dissipating portion **750** may be supported by portions of the upper extending about the heel and ankle of the wearer.

[0082] The branches **780a** and **780b** of the heat-dissipating portion **750** include heat-dissipating reservoirs **786a** and **786b**, respectively. The reservoirs **786a** and **786b** may have a width that is twice the width of the intermediate passageway segments **748a** and **748b** or more to facilitate heat transfer. The reservoirs **786a** and **786b** deliver the fluid **728** to intermediate passageway segments **784a** and **784b**, respectively, which in turn deliver the fluid **728** to a posterior heat-dissipating reservoir **788**. The reservoir **788** may have a width that is twice the width of the intermediate passageway segments **784a** and **784b** or more to facilitate heat transfer. The reservoir **788** delivers the fluid **728** to an anteriorly-extending reservoir inlet passageway segment **772**.

[0083] The reservoir inlet passageway segment **772** includes a check or one-way valve **774**. The check valve **774** permits the reservoir **734** to receive the temperature regulating fluid **728** from the inlet passageway segment **772**. Conversely, the check valve **774** inhibits the inlet passageway segment **772** from receiving the temperature regulating fluid **728** directly from the reservoir **734**. The temperature regulating fluid **728** completes the endless circuit upon traveling from the inlet passageway segment **772** to the reservoir **734**.

[0084] FIGS. 17 and 18 illustrate an article of footwear **810** in accordance with an embodiment of the present invention. The article of footwear **810** may be a casual shoe including a body **812** configured to engage a foot of a wearer (not shown). The body **812** includes a sole **814** having an anteriorly-disposed forefoot-receiving portion **815** and a posteriorly-disposed heel-receiving portion **816**. The sole **814** connects to an upper **818**, and the upper **818** and the sole **814** together define an interior chamber **824** configured to receive the foot of the wearer.

[0085] The body **812** mounts a temperature regulation system **826** that is partially disposed within the interior chamber **824**. The temperature regulation system **826** contains a recirculating temperature regulating fluid **828** that receives heat from the foot of the wearer. The temperature regulating fluid **828** also dissipates heat to the environment of the article of footwear **810**.

[0086] The temperature regulation system **826** defines an endless circuit is formed, in part, by a “pump” or deformable reservoir **834** that contains the temperature regulating fluid **828**. The deformable reservoir **834** is supported by the heel-

receiving portion **816** of the sole **814**. Thus, when the wearer places his/her weight on the heel-receiving portion **816** of the sole **814** (for example, by taking a step, shifting his/her weight, or the like), the reservoir **834** is compressed between the foot of the wearer and the sole **814**. This action causes the reservoir **834** to discharge at least some of the temperature regulating fluid **828** into a plurality of passageway segments that also form, in part, the endless circuit through which the temperature regulating fluid **828** travels. The reservoir **834** specifically discharges the temperature regulating fluid **828** to an anteriorly-extending outlet passageway segment **836**.

[0087] The outlet passageway segment **836** includes a check or one-way valve **838**. The check valve **838** permits the outlet passageway segment **836** to receive the temperature regulating fluid **828** from the reservoir **834**. Conversely, the check valve **838** inhibits the reservoir **834** from receiving the temperature regulating fluid **828** directly from the outlet passageway segment **836**. The outlet passageway segment **836** also delivers the temperature regulating fluid **828** to an adjacent “cooler reservoir” or heat-receiving portion **840** of the temperature regulation system **826**.

[0088] The heat-receiving portion **840** of the temperature regulation system **826** is supported by the forefoot-receiving portion of the sole (not shown) of the article of footwear. Thus, the heat-receiving portion **840** receives heat from the forefoot of the wearer. The heat-receiving portion **840** is a relatively long and wide component to facilitate appropriate heat transfer from the forefoot of the wearer to the heat-receiving portion **840**. In some embodiments, the heat-receiving portion **840** has a width of 70 percent or more of the width of the forefoot-receiving portion **815** of the sole **814**. The heat-receiving portion **840** delivers the temperature regulating fluid **828** to intermediate passageway segments **848a** and **848b**.

[0089] The intermediate passageway segments **848a** and **848b** extend posteriorly from and on opposite sides of the heat-receiving portion **840**. The intermediate passageway segments **848a** and **848b** extend through gaps between the sole **814** and the upper **818**, through passages extending through the upper **818**, or the like. The intermediate passageway segments **848a** and **848b** deliver the temperature regulating fluid **828** to branches **880a** and **880b**, respectively, of a “radiator” or heat-dissipating portion **850**. As the name implies, the heat-dissipating portion **850** dissipates heat from the temperature regulating fluid **828** to the environment. The heat-dissipating portion **850** may be disposed generally evenly relative to the reservoir **834** in an anterior/posterior direction and may also be supported by an upper of the article of footwear (not shown) outside of an interior foot-receiving chamber. The heat-dissipating portion **850** may be supported outside of the internal chamber **824** and by portions of the upper **818** extending about the heel and ankle of the wearer.

[0090] The branches **880a** and **880b** of the heat-dissipating portion **850** include heat-dissipating reservoirs **886a** and **886b**, respectively. The reservoirs **886a** and **886b** may have a width that is twice the width of the intermediate passageway segments **848a** and **848b** or more to facilitate heat transfer. The reservoirs **886a** and **886b** deliver the fluid **828** anteriorly-extending reservoir inlet passageway segments **872a** and **872b**, respectively.

[0091] The reservoir inlet passageway segments **872a** and **872b** extend through gaps between the sole **814** and the upper **818**, through passages extending through the upper **818**, or the like. The reservoir inlet passageway segments **872a** and

872b include check or one-way valves 874a and 874b, respectively. The check valves 874a and 874b permit the reservoir 834 to receive the temperature regulating fluid 828 from the inlet passageway segments 872a and 874b, respectively. Conversely, the check valves 874a and 874b inhibit the inlet passageway segments 872a and 872b, respectively, from receiving the temperature regulating fluid 828 directly from the reservoir 834. The temperature regulating fluid 828 completes the endless circuit upon traveling from the inlet passageway segments 872a and 872b to the reservoir 834.

[0092] FIGS. 19-23 illustrate a temperature regulating fluid control element 900. The control element 900 may be used, for example, with any of the temperature regulation systems and articles of footwear described above. The control element 900 is selectively adjustable to modify the resistance to flow applied to the temperature regulation fluid moving through the system. The control element 900 thereby controls the amount of heat dissipation facilitated by the temperature regulation system.

[0093] In some embodiments and as shown in the figures, the temperature regulating fluid control element 900 includes a base 902 that rotatably mounts a dial 904. The dial 904 supports a protrusion 906 proximate one of the temperature regulating fluid passageway segments 908. As the dial 904 is rotated, the protrusion 906 compresses, in varying degrees, the temperature regulating fluid passageway segment 908 and thereby modifies the resistance to flow applied to the temperature regulation fluid moving through the system.

[0094] Some embodiments according to the present invention have been shown to have a reduced interior chamber temperature compared to articles of footwear that lack temperature regulation systems. Specifically, the data shown in Table 1 have been obtained.

TABLE 1

Temperatures for articles of footwear having and lacking temperature regulation systems at various times.			
Time	Article having temperature regulation system		Article lacking temperature regulation system
	Interior chamber temp. (degrees C.)	Outside heat-dis. portion temp. (degrees C.)	Interior chamber temp. (degrees C.)
Start	30.2	25.0	30.0
One Hour	32.0	28.8	34.1
Two Hours	32.6	30.2	35.2

[0095] As described briefly above, temperature regulation systems according to embodiments of the present invention may be formed by two flexible polyurethane sheets. During manufacturing, in some embodiments, the sheets may first be cut to form the general shape, or outline, of the temperature regulation system. The check valves could then be disposed at the appropriate positions between then sheets. The polyurethane sheets could then be joined (via, for example, bonding, welding, or the like) at many of the edges of the reservoir and the passageway segments. The temperature regulating fluid could be injected through an open edge of a passageway segment to fill the temperature regulation system. The open edge of the passageway segment could then be closed (via, for

example, bonding, welding, or the like), and the temperature regulation system could then be mounted to the body of an article of footwear.

[0096] Articles of footwear according to the present invention may be modified from the embodiments described above in various other manners. For example, the compressible reservoir could be omitted, and the heat-receiving portion could act as the compressible reservoir to drive the temperature regulating fluid along the endless circuit. As another example, various other types of articles of footwear may be used, and different combinations of types of articles of footwear and the various embodiments of the temperature regulation system described above may be created. As yet another example, the positions of the heat-receiving portion and the deformable reservoir of the temperature regulation system may be varied, or the positions of the heat-receiving portion and the deformable reservoir may be reversed. That is, the heat-receiving portion may be supported by the heel-receiving portion of the sole and the deformable reservoir may be supported by the forefoot-receiving portion of the sole.

[0097] Various modifications and additions can be made to the exemplary embodiments discussed without departing from the scope of the present invention. For example, while the embodiments described above refer to particular features, the scope of this invention also includes embodiments having different combinations of features and embodiments that do not include all of the above described features.

The following is claimed:

1. An article of footwear, comprising:
 - a body configured to receive a foot of a wearer of the article of footwear;
 - a temperature regulation system supported by the body and including:
 - a reservoir containing a temperature regulating fluid configured to receive heat from the foot of the wearer, the reservoir being configured to be compressed between the foot of the wearer and the body to discharge the temperature regulating fluid from the reservoir; and
 - a heat-dissipating portion receiving the temperature regulating fluid from the reservoir, the heat-dissipating portion being configured to permit the temperature regulating fluid to dissipate heat received from the foot of the wearer.
2. The article of footwear of claim 1, wherein the reservoir and the heat-dissipating portion define an endless circuit along which the temperature regulating fluid travels.
3. The article of footwear of claim 1, wherein the body includes a sole supporting the reservoir.
4. The article of footwear of claim 3, wherein the sole includes a heel-receiving portion supporting the reservoir.
5. The article of footwear of claim 3, further comprising a footbed configured to engage the foot of the wearer, the footbed overlying the reservoir and the sole.
6. The article of footwear of claim 3, wherein the sole includes a forefoot-receiving portion supporting the reservoir.
7. The article of footwear of claim 6, wherein the reservoir includes a plurality of segments defining a serpentine path along which the temperature regulating fluid travels.
8. The article of footwear of claim 1, wherein the body includes an upper defining a chamber configured to receive

the foot of the wearer, the reservoir being disposed within the chamber and the heat-dissipating portion being disposed outside of the chamber.

- 9. An article of footwear, comprising:
 - a body defining a chamber configured to receive a foot of a wearer of the article of footwear;
 - a temperature regulation system supported by the body and containing a temperature regulating fluid configured to receive heat from the foot of the wearer, the temperature regulation system including a plurality of passageway segments defining an endless circuit through which the temperature regulating fluid travels, and the plurality of passageway segments defining a heat-dissipating portion disposed outwardly of the chamber and configured to permit the temperature regulating fluid to dissipate heat received from the foot of the wearer.

10. The article of footwear of claim 9, wherein the heat-dissipating portion defines a serpentine portion of the endless circuit.

11. The article of footwear of claim 9, wherein the temperature regulation system further includes a reservoir containing the temperature regulating fluid and configured to be compressed between the foot of the wearer and the body to discharge the temperature regulating fluid from the reservoir, and the heat-dissipating portion receiving the temperature regulating fluid from the reservoir.

12. The article of footwear of claim 9, wherein the plurality of passageway segments further define a heat-receiving portion of the endless circuit in which the temperature regulating fluid receives heat from the foot of the wearer, the heat-dissipating portion receiving the temperature regulating fluid from the heat-receiving portion.

13. The article of footwear of claim 12, wherein the body includes a sole supporting the heat-receiving portion of the temperature regulation system.

14. The article of footwear of claim 12, wherein the heat-receiving portion defines a serpentine portion of the endless circuit.

- 15. An article of footwear, comprising:
 - a sole configured to support a foot of a wearer of the article of footwear;
 - an upper supported by the sole, the upper and the sole together defining a chamber configured to receive the foot of the wearer;

a temperature regulation system containing a temperature regulating fluid configured to receive heat from the foot of the wearer, the temperature regulation system including:

- a reservoir supported by the sole and containing the temperature regulating fluid, the reservoir being configured to be compressed between the foot of the wearer and the sole to discharge the temperature regulating fluid from the reservoir;
- a heat-receiving portion supported by the sole within the chamber and receiving the temperature regulating fluid from the reservoir, the heat-receiving portion being configured to permit the temperature regulating fluid to receive heat from the foot of the wearer; and
- a heat-dissipating portion supported by the upper outside of the chamber and receiving the temperature regulating fluid from the heat-receiving portion, the heat-dissipating portion being configured to permit the temperature regulating fluid to dissipate heat received from the foot of the wearer.

16. The article of footwear of claim 15, wherein the heat-receiving portion defines a serpentine portion of a path along which the temperature regulating fluid travels.

17. The article of footwear of claim 15, wherein the heat-dissipating portion defines a serpentine portion of a path along which the temperature regulating fluid travels.

18. The article of footwear of claim 15, wherein the reservoir, the heat-receiving portion, and the heat-dissipating portion define an endless circuit along which the temperature regulating fluid travels.

19. The article of footwear of claim 18, wherein the temperature regulation system further includes a first check valve inhibiting the temperature regulating fluid discharged from the reservoir from traveling along the endless circuit directly toward the heat-dissipating portion.

20. The article of footwear of claim 19, wherein the temperature regulation system further includes a second check valve inhibiting the temperature regulating fluid discharged from the heat-receiving portion from traveling along the endless circuit directly toward the reservoir.

* * * * *