

(No Model.)

C. WOLCOTT.

FASTENER FOR THE MEETING RAILS OF SASHES.

No. 383,549.

Patented May 29, 1888.

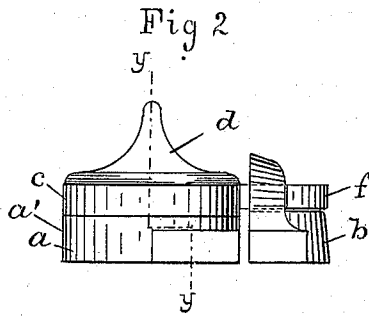
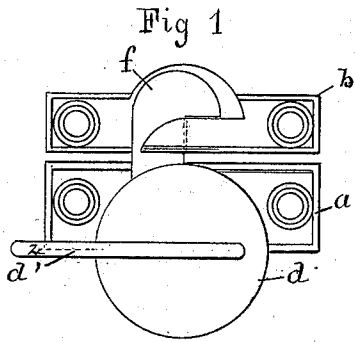

Fig 3

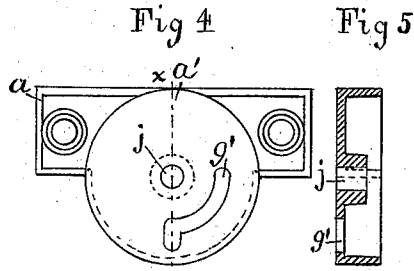
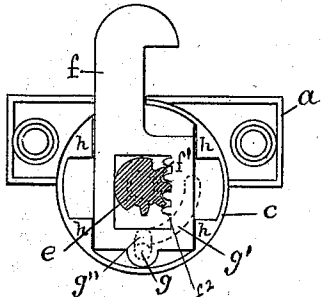

Fig 6

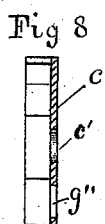
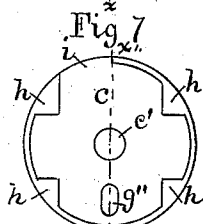
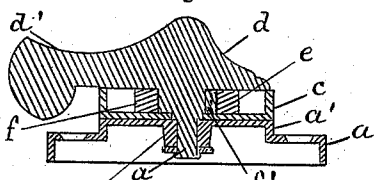

Fig 9

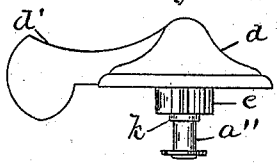
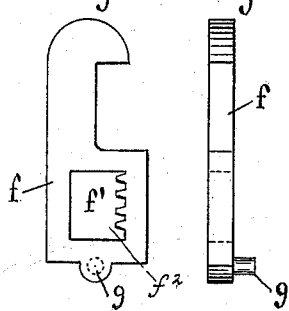

Fig 10

Fig 11



Witnesses.  
*M. E. Hawthall.*  
*Albert M. Roberts.*

Inventor.  
*Clayton Wolcott.*

# UNITED STATES PATENT OFFICE.

CLAYTON WOLCOTT, OF HARTFORD, CONNECTICUT.

## FASTENER FOR THE MEETING-RAILS OF SASHES.

SPECIFICATION forming part of Letters Patent No. 383,549, dated May 29, 1888.

Application filed November 10, 1887. Serial No. 254,744. (No model.)

*To all whom it may concern:*

Be it known that I, CLAYTON WOLCOTT, of Hartford, in the county of Hartford and State of Connecticut, have invented certain new and useful Improvements in Window and Door Buttons, of which the following is a full, clear, and exact description, whereby any one skilled in the art can make and use the same.

My improvement relates more especially to the class of fastening devices that are adapted to be secured to the purpose of fastening them; and to this end my invention consists in the combination of the base-plate, the rotary bearer mounted thereon, the sliding latch interposed between the disk, and a rotary cap with a shank bearing a segment of a gear intermeshing with teeth upon the base of the hook; and it further consists in details of the several parts making up the device and their combination, as more particularly hereinafter described, and pointed out in the claims.

Referring to the drawings, Figure 1 is a top or plan view of my improved fastening device. Fig. 2 is a side view of the same, looking from the right of Fig. 1. Fig. 3 is a top view of the base-plate and sliding latch, the knob-plate being removed and its stem shown in section. Fig. 4 is a top view of the base-plate. Fig. 5 is a detail view, in central cross-section, through the base-plate, on plane denoted by line  $xx$  of Fig. 4. Fig. 6 is a detail view, in longitudinal section, through the parts shown in Fig. 2, on plane denoted by dotted line  $yy$ . Fig. 7 is a detail top view of the bearer. Fig. 8 is a detail view, in cross-section, through said bearer, on plane denoted by line  $x'x'$  of Fig. 7. Fig. 9 is a detail view of the lever-cap with its appurtenant gear and pivot-pin. Fig. 10 is a detail plan view of the latch. Fig. 11 is a detail edge view of the same, looking from the right of Fig. 10.

In the accompanying drawings, the letter  $a$  denotes the base-plate of a window-fastener, adapted to be secured, as by means of screws, to the meeting-rail of a lower window-sash in the usual position, the raised central portion,  $a'$ , of the plate being of circular outline and having the central pivot-hole,  $j$ . There is also formed in the surface of this plate a curved slot,  $g'$ , that has an angular extension in the direction of the radius of the part  $a'$  at a point

diametrically opposite the bearing-face of the striking plate  $b$ . The central part of the bed-plate forms a support for a circular bearer,  $c$ , that has a flat bottom with an upturned peripheral flange, through which is an opening,  $i$ , for the passage of the latch  $f$ , that is located within the recess of the bearer between the lugs  $h$ , that are on opposite sides of the center of the bearer. This latch has on the outer end a hook or projection for the purpose of engaging the upright lug on the striking plate, while its inner end has a slot,  $f'$ , on one side of which are arranged a number of teeth that project inwardly. On the lower side of the inner end of the latch is the pin  $g$ , that passes through the slot  $g^2$  in the bottom of the bearer  $c$ , and enters the slot  $g'$ , formed in the base-plate. The bearer is held upon the base-plate by the cap  $d$  and the pivot-pin  $a^2$ , the latter having a shoulder,  $k$ , that rests upon the top of the base-plate  $a$ , while the part just above the shoulder passes through the hole  $c'$  in the bearer. This construction permits the cap to be fastened to the base-plate without clamping the bearer against rotation.

On that part of the pivot that rests within the latch-socket in the bearer is a segment of a pinion,  $e$ , the teeth of which intermesh with the teeth  $f^2$  on the latch  $f$  when the several parts are assembled, as shown in Fig. 3. The lever  $d'$  is secured to the cap  $d$  as a means of rotating the cap and its appurtenant pinion, and the lever is used in locking and unlocking the latch.

When the parts are fastened, as shown in Fig. 1, a rotary movement of the cap toward the left causes the pinion to throw the latch outward from the base-plate, and this moves the pin  $g$  along the angular portion of the slot  $g'$ . The clamping hold of the latch upon the striking plate is released, and a continuance of the rotary movement of the cap causes the back of the pinion to strike the end of the central opening in the latch at the time the pin  $g$  enters the curved part of slot  $g'$ . The bearer then turns and carries the latch free of the meeting-rail of the upper sash. By a reverse movement of the cap (toward the right) the latch is caused to engage the striking plate and pulls the sashes together after locking them.

As is shown in Fig. 1 of the drawings, the

lever  $d'$  is secured to the cap, so that when the latch is fastened this lever will lie in a plane parallel to the joint between the adjacent faces of the two meeting-rails, and in such position it is impossible to reach this lever-handle from the outside for the purpose of picking the lock or fastening. By reason of the location of the pin  $g$  on the latch in the angular part of the slot  $g'$ , when the latch is fastened it is impossible to turn the latch by any pressure against its edge; and as the latch is drawn inward by means of the interengaging teeth on the pivot-pin  $a^2$  and on the latch  $f$ , the two sashes are drawn tightly together, so as to make an extremely narrow space, if any, between them, and this forms an additional security against picking the lock.

The particular benefit of my improved fastener rises from the combination, with the base-plate, rotary cap, and sliding latch, of the intermediate bearer.

I claim as my improvement—

1. In a fastening device, in combination with the base-plate having a raised central portion with a pivot-hole, and also a curved

slot terminating in an angular projection, the bearer having a central pivot-opening and a radial slot and a socket adapted to receive and hold a sliding latch, a sliding latch having an inner end fitting within the bearer-socket, with a slot on one side of which are arranged a number of teeth and bearing a downward-projecting pin, the cap fitting upon the bearer-plate bearing on its under side a pinion with teeth engaging the teeth of the latch, and the shouldered pivot whereby the several parts are held together, and the lever-handle, all substantially as described.

2. In a fastening device, in combination with a base-plate having a circular slot with angular projection, a rotary cap pivoted on the base-plate, the bearer interposed between the base-plate and cap, and bearing a sliding latch having a pin projecting through the slot in the bearer and into the slot in the base-plate, all substantially as described.

CLAYTON WOLCOTT.

Witnesses:

ALBERT W. ROBERTS,  
W. E. MARSHALL.