



(22) Date de dépôt/Filing Date: 2006/05/26

(41) Mise à la disp. pub./Open to Public Insp.: 2007/11/26

(45) Date de délivrance/Issue Date: 2011/10/18

(51) Cl.Int./Int.Cl. *E06B 1/26* (2006.01),
E06B 1/56 (2006.01)

(72) Inventeur/Inventor:
CARERI, GIOVANNI, CA

(73) Propriétaire/Owner:
CARERI, GIOVANNI, CA

(74) Agent: ROLSTON, GEORGE A.

(54) Titre : MONTANT DE PORTE

(54) Title: DOOR JAMB

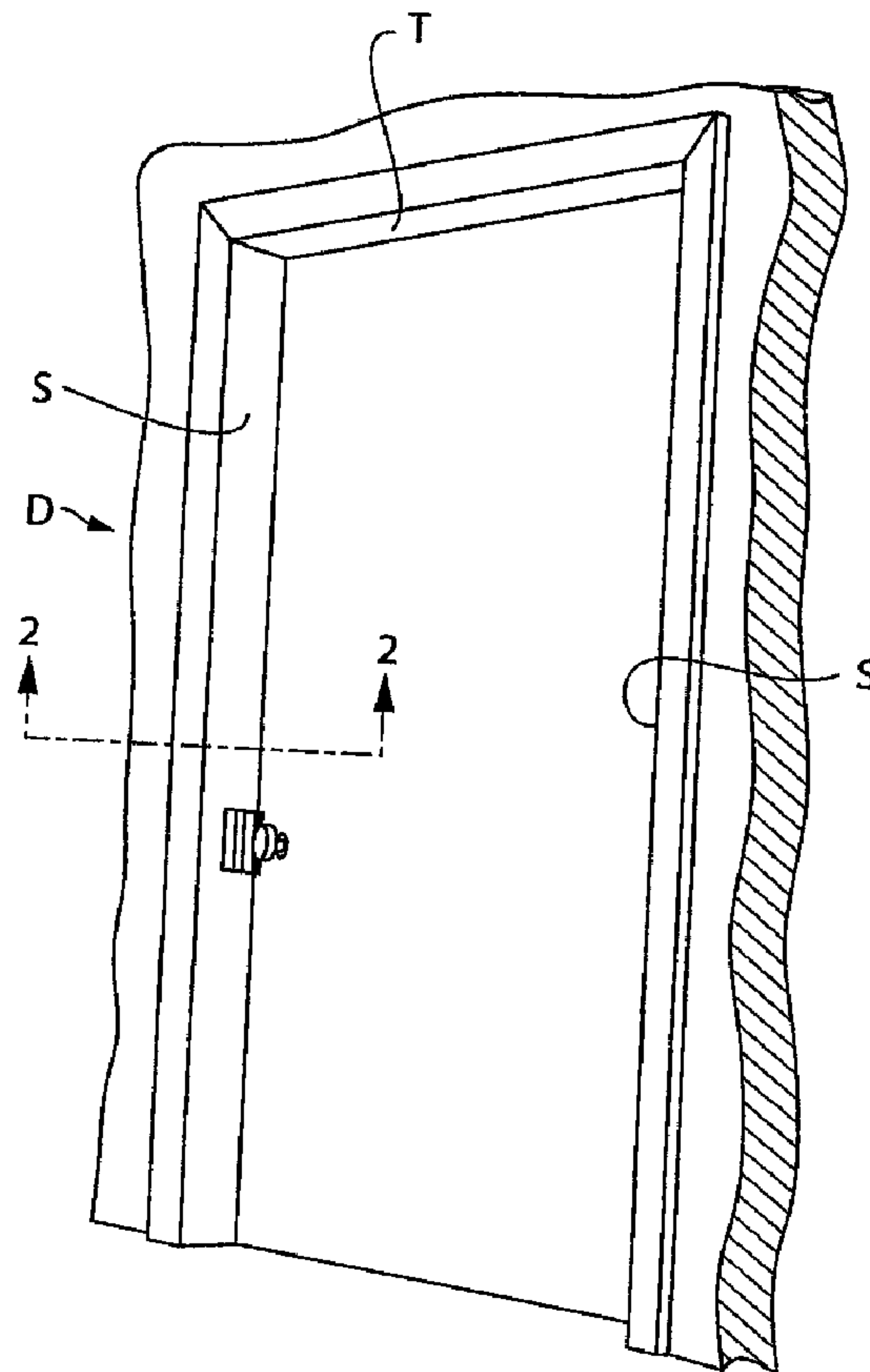

(57) Abrégé/Abstract:

A plastic door jamb member, for forming a portion of a door jamb, the plastic member having a recess for receiving a wooden door jamb portion and; an interlocking attachment recess for interconnection with a metal reinforcement plate, so that the plastic door jamb member may be interengaged with a wooden door jamb portion, and further interengaged with a metal reinforcement plate, and installed in position as a combination door jamb assembly.



ABSTRACT OF THE DISCLOSURE

A plastic door jamb member, for forming a portion of a door jamb, the plastic member having a recess for receiving a wooden door jamb portion and;
an interlocking attachment recess for interconnection with a metal reinforcement plate, so that the plastic door jamb member may be interengaged with a wooden door jamb portion, and further interengaged with a metal reinforcement plate, and installed in position as a combination door jamb assembly.

10

20

FIELD OF THE INVENTION

The invention relates to a door structure for a dwelling or the like in particular to a door jamb for the prefabrication of the a door frame around a doorway.

BACKGROUND OF THE INVENTION

The construction of doorways and doors particularly in dwellings is often carried out simply by installing wooden side plates and a top plate around the door way. Wooden casings are frequently attached to the two edges of the side and top plates. The lock set recesses and hinges are then attached to the plates on opposite sides.

10 This system does not provide for weather proofing. Weather proofing is usually carried out by attaching some form of weather stripping around the edges of the doorway. All of this requires considerable hand work and the exercise of some degree of skill. It is also time consuming and requires on site labour. An added disadvantage however is that by simply installing the lock and hinge hardware in the wooden plates on opposite sides of the doorway, it is relatively easy for intruders to break in. The wood supporting the lock hardware installed in a typical doorway is relatively easily destroyed by a determined intruder, and the door can then simply be swung open.

For these reasons it is desirable that the doorway sideplates shall be reinforced by metal. In this way when the door lock hardware is installed, it will be much more
20 resistant to destruction by an intruder.

Preferably weatherstripping would also be prefabricated for installation at the same time.

In the past there have been some proposals for the use of extruded plastic in the construction of a door jamb. One such example is shown in US Letters Patent

5,787,660. Another example is shown in US Letters Patent 6,557,309. Plastic extruded material has also been used in framing the door itself so as to provide a door sweep, as shown in US Letters Patent 6,345,431. However, none of these systems have provided a door jamb system in which a combination of wooden door jamb plate and a vinyl extrusion for securing weatherproof trim.

BRIEF SUMMARY OF THE INVENTION

10 With a view to simplifying the foregoing structures and providing an improved combination door jamb assembly, the invention comprises a plastic extrusion member, for forming a first portion of a door jamb, the extrusion member defining a generally channel shaped recess for receiving a wooden door jamb portion in interengagement, and the extrusion member further defining an interlocking attachment recess for interconnection with a metal reinforcement plate, whereby the plastic extrusion member may be interengaged with a wooden door jamb plate, and further interengaged with a metal reinforcement plate, and installed in position as a combination door jamb assembly.

Preferably, in accordance with the invention a plastic extrusion member further defines at least one channel shaped recess for receiving weather strip material therein.

20 Preferably, the plastic extrusion member will further include an additional interlocking recess for receiving an exterior trim, attachable to the vinyl extrusion around the exterior of the doorway, and providing an attractive finished appearance.

Preferably, the invention will further provide a hook engagement for interengaging with a recess on the wooden door jamb, so that the two may be interengaged together and held securely.

In a further preferred feature, two such hook interengagements are provided, interengaging with suitable channels on opposite sides of the wooden door jamb, so as to securely engage it from opposite sides.

Preferably, the invention further provides a suitable fastening receiving face on the plastic extrusion through which a fastening may be passed into the wooden door jamb thereby permanently securing it in position.

Preferably, the invention further provides a reduced thickness portion on the wooden door jamb, which is adapted to receive the metal reinforcement plate, and permit the metal reinforcement plate to lie flat against the wooden door jamb.

10 Preferably, the invention further provides that the plastic extrusion member shall have a generally outwardly flared face extending outwardly from the door itself, so as to provide a more attractive entry.

Preferably, the invention further provides that the plastic extrusion member shall incorporate a door stop portion, so that when the door closes, it may securely engage against a portion of the plastic extrusion member.

The invention further comprises a door jamb system having a wooden door jamb portion, an extruded plastic portion and a metallic reinforcement assembled in combination.

20 The various features of novelty which characterize the invention are pointed out with more particularity in the claims annexed to and forming a part of this disclosure.

For a better understanding of the invention, its operating advantages and specific objects attained by its use, reference should be made to the accompanying drawings and descriptive matter in which there are illustrated and described preferred

embodiments of the invention.

IN THE DRAWINGS

Figure 1 is a perspective illustration of a doorway, typically an exterior doorway for a dwelling or the like, illustrating the location and use of the door jamb illustrating the invention;

Figure 2 is a sectional illustration of one side of the doorway along line 2-2 showing the plastic extrusion member, and the wooden door jamb portion and the metal reinforcement plate on the building structure;

10

Figure 3 is a section along the line 3-3 of Figure 2 showing the parts at a first stage of assembly;

Figure 4 is a section along the line 3-3 of Figure 2 showing the parts at a second stage of assembly;

Figure 5 is a section of an alternative embodiment showing the parts at the final stage of assembly.

DESCRIPTION OF A SPECIFIC EMBODIMENT

As explained above the invention relates generally to the provision of a composite door jamb having improved security reinforcement and weather stripping, and which is at the same time substantially prefabricated and therefore easy to install and producing a significant cost saving in terms of on site labour costs.

The invention is illustrated in Figure 1 in general, showing a doorway with a door (D) having side door jambs (S), and a top plate door jamb (T). In many cases these side door jambs and top door jambs were all simply fabricated of wooden material bought in lengths from a lumber yard, and cut to fit and installed in place.

10 Also, as of course is well known, one door jamb (S) is used to receive the lock set recess hardware (not shown) and the other door jamb is adapted for mounting the door hinges (not shown).

All of this is well known.

In addition, such door frames and doorways provide a door stop against which the door abuts when it is closed, and will usually be provided with some form of weather stripping.

In accordance with the invention, these features are provided by a combination form of door jamb (10) comprising a plastic door jamb member (12), a wooden machined frame member (14), and a metal reinforcement plate (16). The plastic door jamb member (12)
20 the wooden frame member (14) and the metal reinforcement plate (16) are interlocked and assembled together in a manner described below, to provide a combination door jamb having an attractive appearance, weather proofing, and substantially increased security.

These three members are secured to the structural wood framing (F) of a building.

Referring now to Figures 3 and 4 it will be seen that the plastic door jamb member (12) comprises a generally hollow plastic extrusion having a doorway outer wall (20), an angled facing plate (22), and an outer trim holding channel (24), forming the majority of the exterior of the doorway. A door stop member (28) is formed at right angles to the door.

On the concealed side of the plastic door jamb member (12), there is a generally rectangular indentation wall (30), connecting with a plate retention groove (34). From the plate retention groove (34), an angled junction wall (36) extends, and a rectangular attachment face (38) extends from the junction wall (36).

From the attachment face (38), a hook extension (40) extends, and is enlarged to provide a generally inwardly sloping surface.

Between the attachment face (38) and outer wall (20), there is a channel (42) defined, and adjacent thereto is an interior channel wall (44).

The interior channel wall (44) extends to meet a weather stripping channel wall (46), which defines a channel for receiving weather stripping.

A further fastening face (48) extends from the weather stripping channel wall (46) and meets door stop member (28).

An interior tooth portion (50) extends from the weather stripping channel wall (46), for reasons to be described below.

In order to cooperate and interfit with the plastic door jamb member (12), the wooden door frame member (14) already referred to is formed with a tapered nose portion (52), having an angled surface (54) formed thereon, for ease of entry into the channel (42) of

the plastic door jamb member (12).

A first locking channel (56) is formed in the inwardly facing surface of the wooden door jamb frame member (14), for interengagement with the hook extension (40) of the plastic extrusion (12). A second locking channel (58) is formed for interengagement with the tooth portion (50) of the plastic door jamb member (12). The two channels (56) and (58) interfit with the hook extension (40) and the tooth portion (50) respectively in the manner shown in Figures 3 and 4. Extension wall (60) extends to overlie the wooden frame member (14).

10 In order to receive and provide a space for the metallic reinforcement plate (16), the wooden frame member (14) is formed with a planar recessed receiving surface (62), which terminates in a shoulder (64).

Metal reinforcement plate(16) has a retention hook (66) to engage a rib (68) of channel (34) on plastic extrusion (12).

In order to secure the wooden frame member (14) in engagement, a staple or nail (not shown) may be inserted through the plastic extrusion (12), extending into the wooden frame member (14).

To provide additional security, a fastener such as a wood screw, Figure 4, may be inserted through the junction wall (36) of the plastic door jamb member (12) and will pass into the angled surface (54) of the nose portion (52) of the wooden frame member
20 (14).

Between wall (22) and indentation (30) interior bracing walls (70) are provided for additional support.

As shown in Figure 5, the extrusion member (12) is usually provided with a door

weatherstrip (72) in channel (46).

The exterior of the door way may be finished with a simple wood molding as shown in Figure 2.

However as an added feature, an exterior finish extrusion (74) may be provided on one side of the doorway. Extrusion (74) is of generally three sided rectangular design defining a channel (76). A facing wall (78) locates extrusion (74) against extrusion member (12). A screen door frame (80) can be secured in an extrusion (82) which fits in channel (76). A trim strip (84) can be placed in a channel (86) on extrusion (74).

On the opposite door jamb, i.e. where the door (D) is hinged, there is an extrusion (90).

10 A roller screen(92) is contained within extrusion (90) and can be extended in the direction of arrow A. Screen door (92) can be extended across the door way, when required and secured to extrusion (74).

The foregoing is a description of a preferred embodiment of the invention which is given here by way of example only. The invention is not to be taken as limited to any of the specific features as described, but comprehends all such variations thereof as come within the scope of the appended claims.

THE EMBODIMENTS OF THE INVENTION IN WHICH AN EXCLUSIVE PROPERTY OR PRIVILEGE IS CLAIMED ARE DEFINED AS FOLLOWS;

1. A plastic door jamb member, for forming a portion of a door jamb within the structural wood framing of door way in a building for use in combination with a wooden door jamb and a metal reinforcement plate, the door jamb comprising;
a wooden door jamb portion defining an inward face and a tapered nose portion ;
a door jamb plastic member in turn comprising;
a hollow plastic extrusion having a doorway outer wall and a concealed side;
a nose channel on said concealed side which receives said tapered nose portion of said wooden door jamb portion ;
a metal reinforcement plate lying flat on said inward face of said wooden door jamb portion , between said structural wood framing of said building and said inward face of said wooden door jamb portion;
a plate retention groove in said hollow plastic extrusion; for engagement by said metal reinforcement plate;
an angled junction wall on said hollow plastic extrusion extending at an angle from said nose channel overlying said tapered nose portion of said wooden door jamb portion;
an angled surface on said tapered nose portion of said wooden door jamb portion;
a fastener passing through said junction wall of said hollow plastic extrusion and secured into said angled surface of said tapered nose portion of said wooden door jamb portion;
a rectangular attachment face extending from said junctional, overlying said nose portion of said wooden door jamb portion;

a retention hook on said metal reinforcement plate engageable in said plate retention groove when said metal reinforcement plate is sandwiched between said structural wood framing of a building and said wooden door jamb portion;

a locking channel formed in said wooden door jamb portion;

a hook extension formed on said rectangular attachment face for interengagement in said locking channel;

a reduced thickness portion on said wooden door jamb portion which is adapted to receive the metal reinforcement plate and permit said metal reinforcement plate to lie flat against said wooden door jamb portion with said metal reinforcement plate overlying said hook extension;

whereby the plastic door jamb member is interengaged with the wooden door jamb portion, and with the metal reinforcement plate, lying flat against the wooden door jamb portion .

2. A plastic door jamb member as claimed in claim 1 including a tooth portion on said door jamb plastic member and a recess in said wooden door jamb portion for interengaging with one another so that the two may be interengaged together and held securely.

3. A plastic door jamb member as claimed in claim 2 including a locking channel on one side of the wooden door jamb portion, and wherein said recess is on an opposite side of said wooden door jamb portion, thereby forming two channels on opposite sides of said wooden door jamb portion.

4. A plastic door jamb member as claimed in claim 1 including a generally outwardly flared face on said plastic door jamb member to provide an entry.
5. A plastic door jamb member as claimed in claim 1 including a trim strip placed in a channel formed on an exterior finish extrusion.
6. A plastic door jamb member as claimed in claim 1 including a screen door frame which fits in a channel and is secured to an exterior finish extrusion, and wherein the exterior finish extrusion is secured to the plastic door jamb member and wherein said screen door comprises a roller screen extendable across the door way.
7. A plastic door jamb member as claimed in claim 1 wherein the door jamb plastic member includes first and second parallel spaced apart upright members and a third door jamb plastic member which is secured to the first and second door jamb plastic members to form a top portion of the door jamb, and, at least one channel shaped recess for receiving a continuous weather strip therein.
8. A plastic door jamb member as claimed in claim 1 wherein the door jamb plastic member includes a door stop portion.

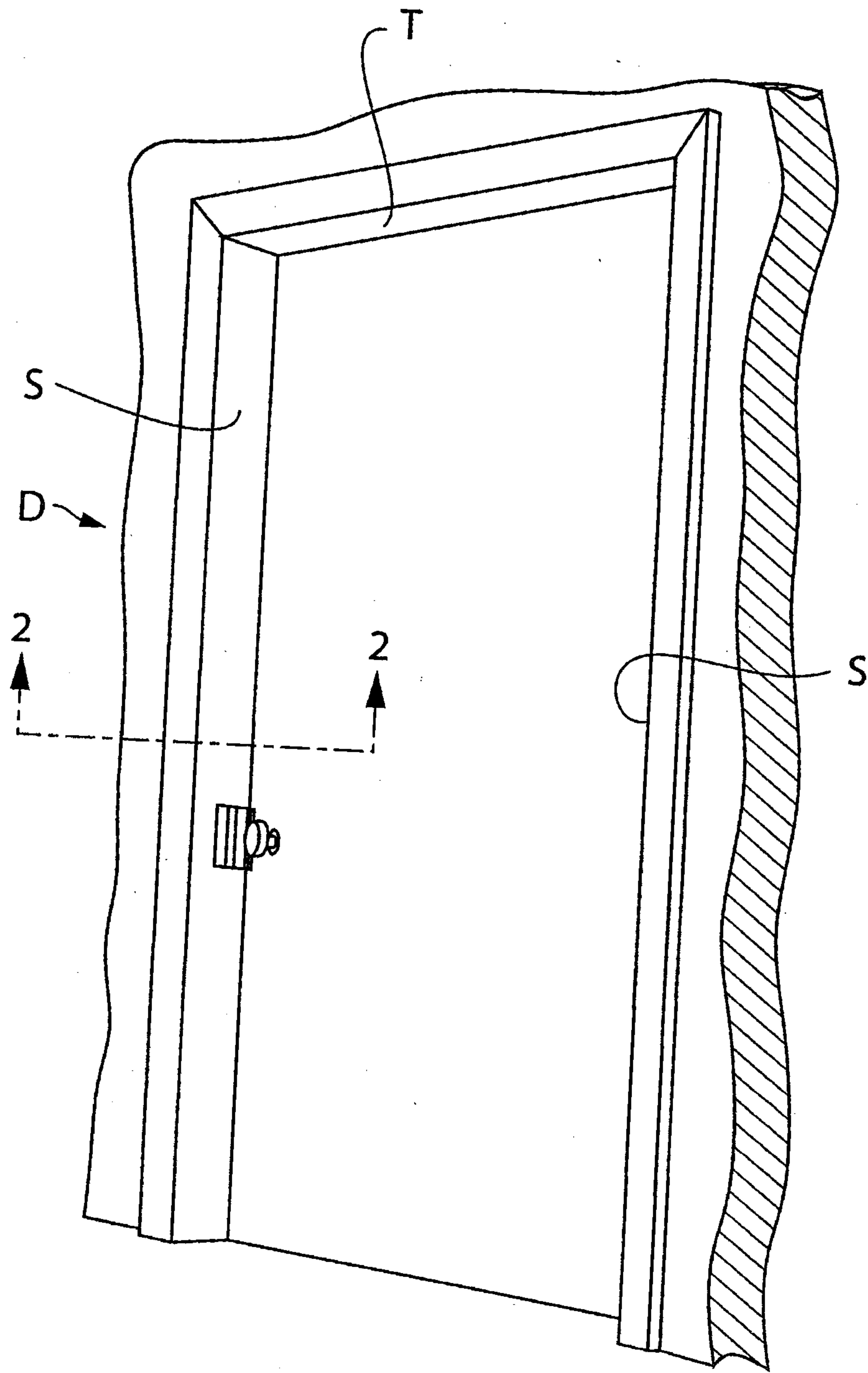

FIG. 1

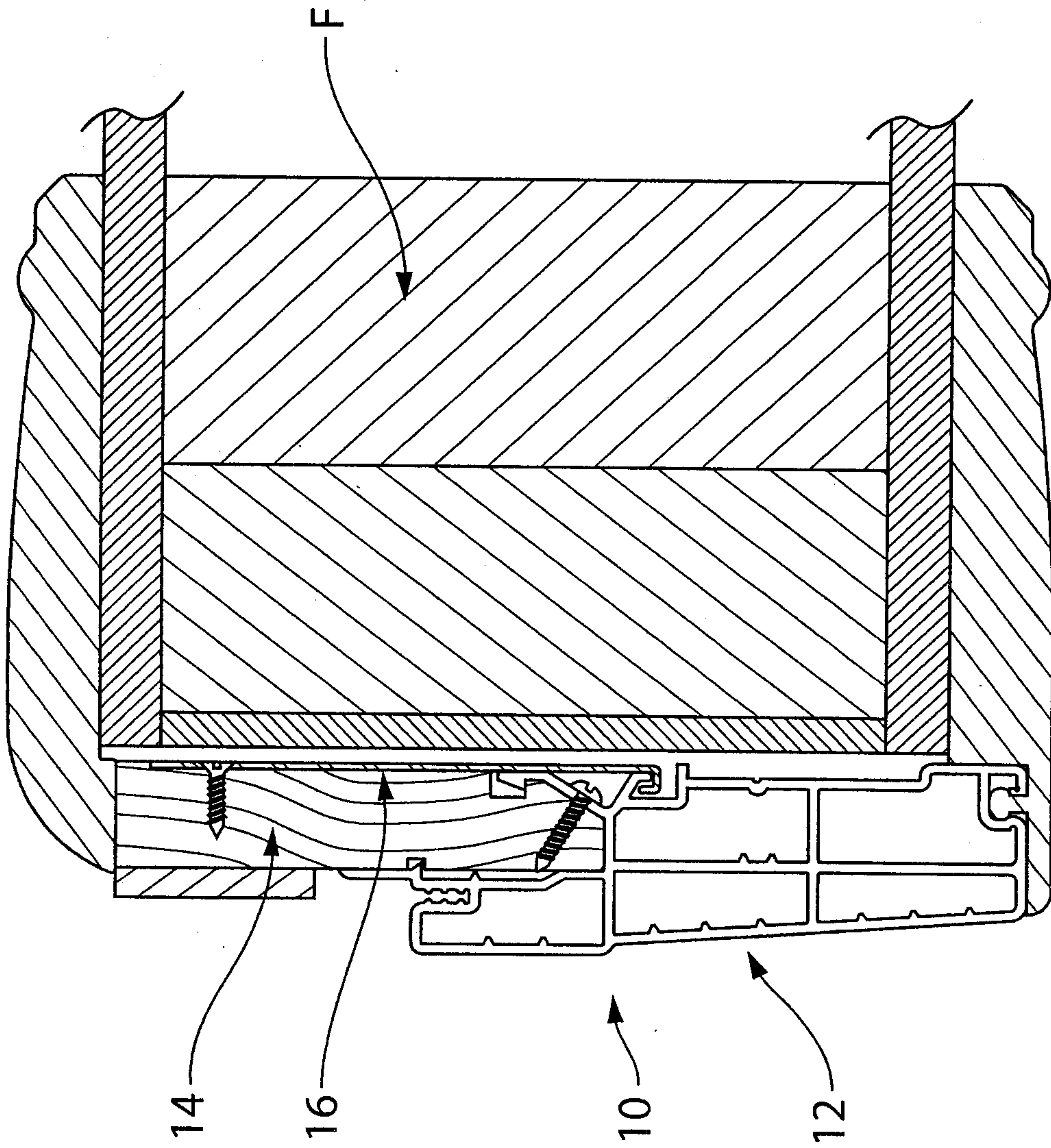

FIG. 2

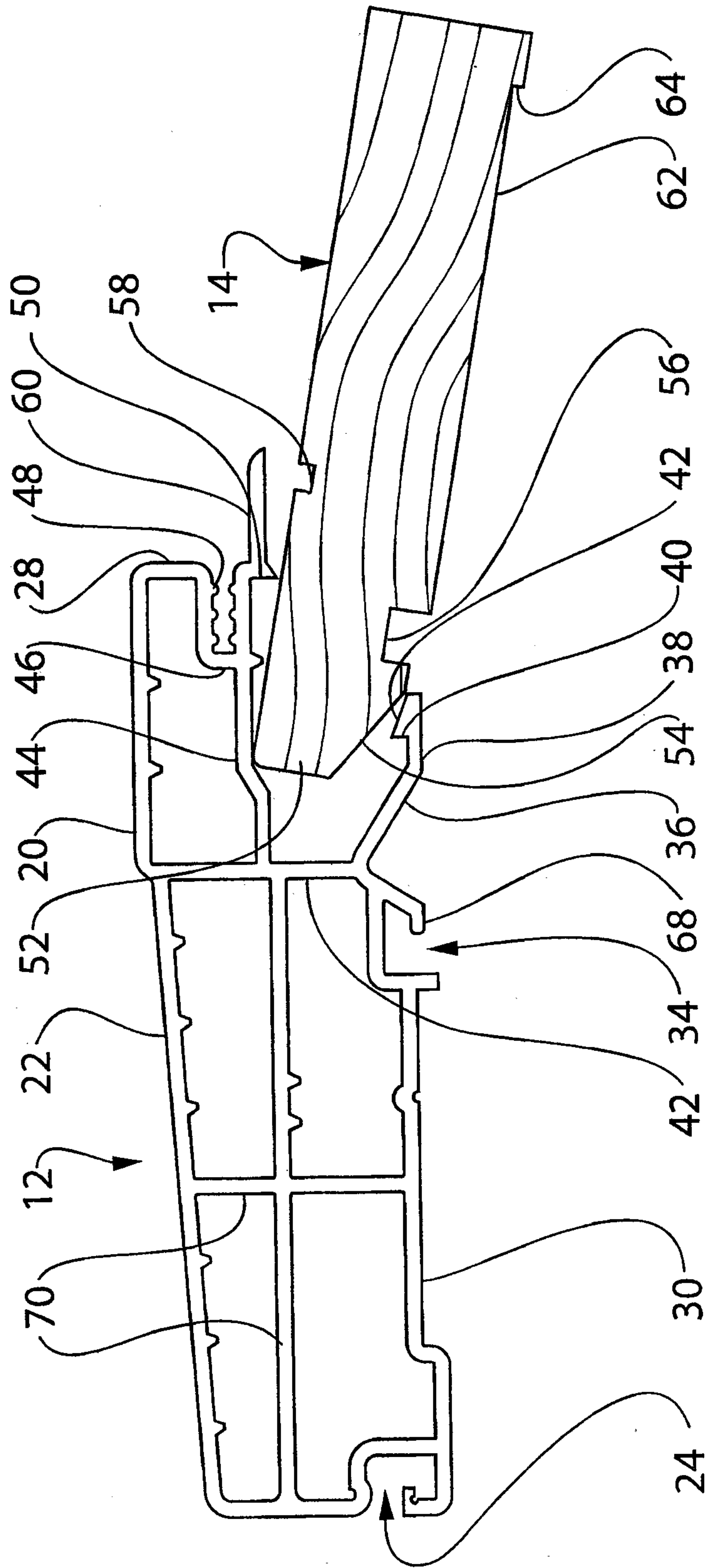

FIG. 3

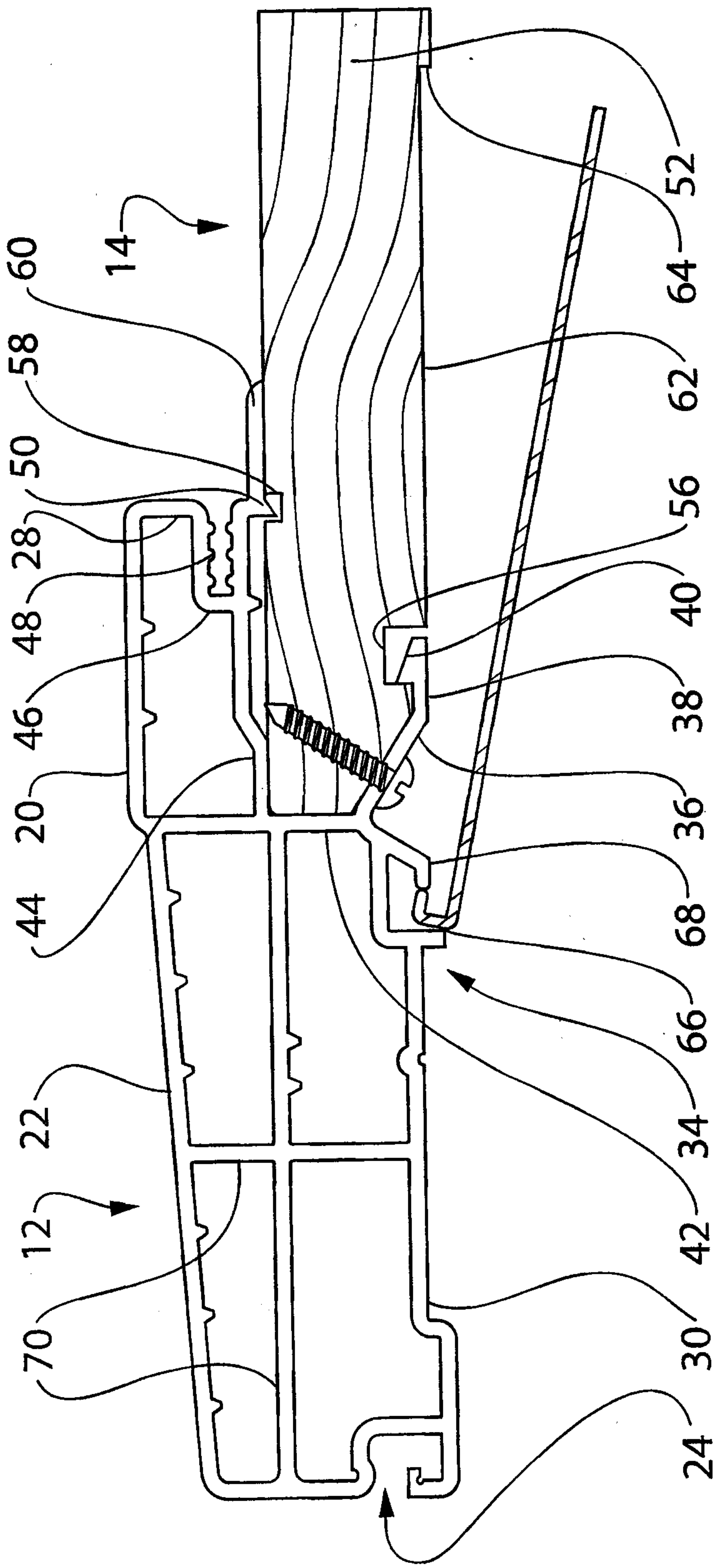

FIG. 4

