

**(12) STANDARD PATENT**  
**(19) AUSTRALIAN PATENT OFFICE**

(11) Application No. **AU 2019203664 B2**

(54) Title  
**COMPOSITIONS AND METHODS FOR PERSONALIZED NEOPLASIA VACCINES**

(51) International Patent Classification(s)  
**A61K 39/00** (2006.01)                      **A61P 35/00** (2006.01)

(21) Application No:   **2019203664**                      (22) Date of Filing:   **2019.05.24**

(43) Publication Date:                      **2019.06.13**

(43) Publication Journal Date:            **2019.06.13**

(44) Accepted Journal Date:              **2021.08.12**

(62) Divisional of:  
**2014251207**

(71) Applicant(s)  
**The Broad Institute, Inc.;Dana-Farber Cancer Institute, Inc.;The General Hospital Corporation**

(72) Inventor(s)  
**Hacohen, Nir;Wu, Catherine J.;Fritsch, Edward F.**

(74) Agent / Attorney  
**Phillips Ormonde Fitzpatrick, PO Box 323, COLLINS STREET WEST, VIC, 8007, AU**

2019203664 24 May 2019

## ABSTRACT

The invention provides a method of making a personalized neoplasia vaccine for a subject diagnosed as having a neoplasia, which includes identifying a plurality of mutations in the neoplasia, analyzing the plurality of mutations to identify a subset of at least five neo-antigenic mutations predicted to encode neo-antigenic peptides, the neo-antigenic mutations selected from the group consisting of missense mutations, neoORF mutations, and any combination thereof, and producing, based on the identified subset, a personalized neoplasia vaccine.

2019203664 24 May 2019

# COMPOSITIONS AND METHODS FOR PERSONALIZED NEOPLASIA VACCINES

## RELATED APPLICATIONS

This application is a divisional of Australian patent application number 2014251207, the entire content of which is incorporated into the present specification by this cross-reference. Australian patent application number 2014251207 is a national phase filing of international patent application number PCT/US2014/033185. PCT/US2014/033185 claims the benefit of and priority to U.S. Provisional Patent Application No. 61/809,406, filed April 7, 2013 and U.S. Provisional Patent Application No. 61/869,721, filed August 25, 2013, the contents of which are incorporated herein by reference.

## FIELD OF THE INVENTION

The present invention relates to personalized strategies for the treatment of neoplasia. More particularly, the present invention relates to the identification and use of a patient specific pool of tumor specific neo-antigens in a personalized tumor vaccine for treatment of the subject.

## BACKGROUND

Approximately 1.6 million Americans are diagnosed with neoplasia every year, and approximately 580,000 people in the United States are expected to die of the disease in 2013. Over the past few decades there been significant improvements in the detection, diagnosis, and treatment of neoplasia, which have significantly increased the survival rate for many types of neoplasia. However, only about 60% of people diagnosed with neoplasia are still alive 5 years after the onset of treatment, which makes neoplasia the second leading cause of death in the United States.

Currently, there are a number of different existing cancer therapies, including ablation techniques (e.g., surgical procedures, cryogenic/heat treatment, ultrasound, radiofrequency, and radiation) and chemical techniques (e.g., pharmaceutical agents, cytotoxic/chemotherapeutic agents, monoclonal antibodies, and various combinations thereof). Unfortunately, such therapies are frequently associated with serious risk, toxic side effects, and extremely high costs, as well as

uncertain efficacy.

There is a growing interest in cancer therapies that seek to target cancerous cells with a patient's own immune system (e.g., cancer vaccines) because such therapies may mitigate/eliminate some of the above-described disadvantages. Cancer vaccines are typically composed of tumor antigens and immunostimulatory molecules (e.g., cytokines or TLR ligands) that work together to induce antigen-specific cytotoxic T cells that target and destroy tumor cells. Current cancer vaccines typically contain shared tumor antigens, which are native proteins (i.e. – proteins encoded by the DNA of all the normal cells in the individual) that are selectively expressed or over-expressed in tumors found in many individuals. While such shared tumor antigens are useful in identifying particular types of tumors, they are not ideal as immunogens for targeting a T-cell response to a particular tumor type because they are subject to the immune dampening effects of self-tolerance. Accordingly, there is a need for methods of identifying more effective tumor antigens that may be used for neoplasia vaccines.

#### SUMMARY OF THE INVENTION

The present invention relates to a strategy for the personalized treatment of neoplasia, and more particularly to the identification and use of a personalized cancer vaccine consisting essentially of a pool of tumor-specific and patient-specific neo-antigens for the treatment of tumors in a subject. As described below, the present invention is based, at least in part, on the discovery that whole genome/exome sequencing may be used to identify all, or nearly all, mutated neo-antigens that are uniquely present in a neoplasia/tumor of an individual patient, and that this collection of mutated neo-antigens may be analyzed to identify a specific, optimized subset of neo-antigens for use as a personalized neoplasia vaccine for treatment of the patient's neoplasia/tumor.

In one aspect, the present invention a method of inducing an immune response in a subject having a neoplasia, the method comprising administering to the subject an immunogenic composition that is specific to both the subject and the neoplasia, wherein the immunogenic composition comprises: (a) an optimized subset of at least five neo-antigenic peptides identified from the subject, wherein the at least five neo-antigenic peptides collectively have a higher ranking order than other neo-antigenic peptides identified from the subject collectively do; or (b)

one or more polynucleotides encoding the at least five neo-antigenic peptides, wherein the ranking order in decreasing priority comprises:

- (i) a neoORF polypeptide that binds to the HLA of the subject with a  $K_d$  of  $\leq 500$  nM encoded by a sequence comprising a neoORF mutation;
- (ii) a polypeptide that binds to the HLA of the subject with a  $K_d$  of  $\leq 150$  nM encoded by a sequence comprising a missense mutation, wherein the native cognate protein has a  $K_d$  of  $\geq 1000$  nM;
- (iii) a polypeptide that binds to the HLA of the subject with a  $K_d$  of  $\leq 150$  nM encoded by a sequence comprising a missense mutation, wherein the native cognate protein has a  $K_d$  of  $\leq 150$  nM;
- (iv) a neoORF polypeptide that binds to the HLA of the subject with a  $K_d$  of  $> 500$  nM encoded by a sequence comprising a neoORF mutation; and
- (v) a polypeptide that binds to the HLA of the subject with a  $K_d$  of  $150- \leq 500$  nM encoded by a sequence comprising a missense mutation, wherein the native cognate protein has a  $K_d$  of  $150- \leq 500$  nM.

In a further aspect, the present invention provides a method of treating a neoplasia comprising administering a composition to a subject having the neoplasia, wherein the composition is specific to both the subject and the neoplasia, and wherein the composition comprises:

- (a) an optimized subset of at least five neo-antigenic peptides identified from the subject, wherein the at least five neo-antigenic peptides collectively have a higher ranking order than other neo-antigenic peptides identified from the subject collectively do;
- (b) one or more polynucleotides encoding the at least five neo-antigenic peptides;
- (c) antigen-presenting cells that have been pulsed with the at least five neo-antigenic peptides; or
- (d) T cells from the subject that are specific to a complex of a protein encoded by an HLA allele expressed by the subject and one or more neo-epitopes of the at least five neo-antigenic peptides, wherein the T cells have been stimulated *ex vivo* with the at least five

neo-antigenic peptides, and wherein the ranking order in decreasing priority for the neo-antigenic peptides comprises:

- (i) a neoORF polypeptide that binds to the HLA of the subject with a  $K_d$  of  $\leq 500$  nM encoded by a sequence comprising a neoORF mutation;
- (ii) a polypeptide that binds to the HLA of the subject with a  $K_d$  of  $\leq 150$  nM encoded by a sequence comprising a missense mutation, wherein the native cognate protein has a  $K_d$  of  $\geq 1000$  nM;
- (iii) a polypeptide that binds to the HLA of the subject with a  $K_d$  of  $\leq 150$  nM encoded by a sequence comprising a missense mutation, wherein the native cognate protein has a  $K_d$  of  $\leq 150$  nM;
- (iv) a neoORF polypeptide that binds to the HLA of the subject with a  $K_d$  of  $> 500$  nM encoded by a sequence comprising a neoORF mutation; and
- (v) a polypeptide that binds to the HLA of the subject with a  $K_d$  of  $150- \leq 500$  nM encoded by a sequence comprising a missense mutation, wherein the native cognate protein has a  $K_d$  of  $150- \leq 500$  nM.

In a further aspect, the present invention provides a method comprising:

- (a) obtaining a first set of nucleic acid sequences from a neoplasia of a subject and a second set of nucleic acid sequences from non-neoplasia cells of the subject;
- (b) identifying a plurality of sequences comprising mutations in the neoplasia, wherein the plurality of sequences are present in the first set but not in the second set, wherein the plurality of sequences encode candidate peptide sequences comprising different mutations, and wherein the plurality of sequences are expressed by the neoplasia of the subject;
- (c) analyzing the plurality of sequences comprising mutations to identify at least five neo-antigenic sequences comprising neo-antigenic mutations predicted to encode the optimized subset of at least five neo-antigenic peptides, the neo-antigenic mutations being selected from the group consisting of missense mutations, neoORF mutations, and any combination thereof, said analyzing comprising:

identifying sequences comprising neo-antigenic mutations from the plurality of sequences comprising mutations identified in the neoplasia; and

ranking the neo-antigenic peptides encoded by the sequences comprising the neo-antigenic mutations in a ranking order of decreasing priority, the ranking order comprising:

(i) a neoORF polypeptide that binds to the HLA of the subject with a  $K_d$  of  $\leq 500$  nM encoded by a sequence comprising a neoORF mutation;

(ii) a polypeptide that binds to the HLA of the subject with a  $K_d$  of  $\leq 150$  nM encoded by a sequence comprising a missense mutation, wherein the native cognate protein has a  $K_d$  of  $\geq 1000$  nM;

(iii) a polypeptide that binds to the HLA of the subject with a  $K_d$  of  $\leq 150$  nM encoded by a sequence comprising a missense mutation, wherein the native cognate protein has a  $K_d$  of  $\leq 150$  nM;

(iv) a neoORF polypeptide that binds to the HLA of the subject with a  $K_d$  of  $> 500$  nM encoded by a sequence comprising a neoORF mutation; and

(v) a polypeptide that binds to the HLA of the subject with a  $K_d$  of  $150- \leq 500$  nM encoded by a sequence comprising a missense mutation, wherein the native cognate protein has a  $K_d$  of  $150- \leq 500$  nM; and

(d) producing, based on the identified subset, a personalized neoplasia vaccine.

Also described herein is a method of making a personalized neoplasia vaccine for a subject diagnosed as having a neoplasia, which includes identifying a plurality of mutations in the neoplasia, analyzing the plurality of mutations to identify a subset of at least five neo-antigenic mutations predicted to encode neo-antigenic peptides, the neo-antigenic mutations selected from the group consisting of missense mutations, neoORF mutations, and any combination thereof, and producing, based on the identified subset, a personalized neoplasia vaccine.

24 May 2019

2019203664

In an embodiment, the invention provides that the identifying step further includes sequencing the genome, transcriptome, or proteome of the neoplasia.

In another embodiment, the analyzing step may further include determining one or more characteristics associated with the subset of at least five neo-antigenic mutations predicted to encode neo-antigenic peptides, the characteristics selected from the group consisting of molecular weight, cysteine content, hydrophilicity, hydrophobicity, charge, and binding affinity; and ranking, based on the determined characteristics, each of the neo-antigenic mutations within the identified subset of at least five neo-antigenic mutations. In an embodiment, the top 5-30 ranked neo-antigenic mutations are included in the personalized neoplasia vaccine. In another embodiment, the neo-antigenic mutations are ranked according to the order shown in FIG. 8.

In one embodiment, the personalized neoplasia vaccine comprises at least about 20 neo-antigenic peptides corresponding to the neo-antigenic mutations.

In another embodiment, the personalized neoplasia vaccine comprises one or more DNA molecules capable of expressing at least about 20 neo-antigenic peptides corresponding to the neo-antigenic mutations. In another embodiment, the personalized neoplasia vaccine comprises one or more RNA molecules capable of expressing at least 20 neo-antigenic peptides corresponding to the neo-antigenic mutations.

In embodiments, the personalized neoplasia vaccine comprises neoORF mutations predicted to encode a neoORF polypeptide having a Kd of  $\leq 500$  nM.

In another embodiment, the personalized neoplasia vaccine comprises missense mutations predicted to encode a polypeptide having a Kd of  $\leq 150$  nM, wherein the native cognate protein has a Kd of  $\geq 1000$  nM or  $\leq 150$  nM.

25 In another embodiment, the at least about 20 neo-antigenic peptides range from about 5 to about 50 amino acids in length. In another embodiment, the at least about 20 neo-antigenic peptides range from about 15 to about 35 amino acids in length. In another embodiment, the at least about 20 neo-antigenic peptides range from about 18 to about 30 amino acids in length. In another embodiment, the at least about 20 neo-antigenic peptides range from about 6 to about 15 amino acids in length. In yet another embodiment, the at least about 20 neo-antigenic peptides are 15, 16, 17, 18, 19, 20, 21, 22, 23, 24, or 25 amino acids in length.

30 In one embodiment, the personalized neoplasia vaccine further includes an adjuvant. In other embodiments, the adjuvant is selected from the group consisting of poly-ICLC, 1018 ISS,



2019203664 24 May 2019

aluminum salts, Amplivax, AS15, BCG, CP-870,893, CpG7909, CyaA, dSLIM, GM-CSF, IC30, IC31, Imiquimod, ImuFact IMP321, IS Patch, ISS, ISCOMATRIX, JuvImmune, LipoVac, MF59, monophosphoryl lipid A, Montanide IMS 1312, Montanide ISA 206, Montanide ISA 50V, Montanide ISA-51, OK-432, OM-174, OM-197-MP-EC, ONTAK, PepTel.RTM, vector system, PLGA microparticles, resiquimod, SRL172, Virosomes and other Virus-like particles, YF-17D, VEGF trap, R848, beta-glucan, Pam3Cys, Aquila's QS21 stimulon, vadimezan, and/or AsA404 (DMXAA). In a preferred embodiment, the adjuvant is poly-ICLC.

In another aspect, the invention includes a method of treating a subject diagnosed as having a neoplasia with a personalized neoplasia vaccine, which includes identifying a plurality of mutations in the neoplasia; analyzing the plurality of mutations to identify a subset of at least five neo-antigenic mutations predicted to encode expressed neo-antigenic peptides, the neo-antigenic mutations selected from the group consisting of missense mutations, neoORF mutations, and any combination thereof; producing, based on the identified subset, a personalized neoplasia vaccine; and administering the personalized neoplasia vaccine to the subject, thereby treating the neoplasia.

In another embodiment, the identifying step may further include sequencing the genome, transcriptome, or proteome of the neoplasia.

In yet another embodiment, the analyzing step may further include determining one or more characteristics associated with the subset of at least five neo-antigenic mutations predicted to encode expressed neo-antigenic peptides, the characteristics selected from the group consisting of molecular weight, cysteine content, hydrophilicity, hydrophobicity charge, and binding affinity; and ranking, based on the determined characteristics, each of the neo-antigenic mutations within the identified subset of at least five neo-antigenic mutations.

25 In one embodiment, the top 5-30 ranked neo-antigenic mutations are included in the personalized neoplasia vaccine. In another embodiment, the neo-antigenic mutations are ranked according to the order shown in FIG. 8.

In one embodiment, the personalized neoplasia vaccine comprises at least 20 neo-antigenic peptides corresponding to the neo-antigenic mutations.

30 In another embodiment, the personalized neoplasia vaccine comprises one or more DNA molecules capable of expressing at least 20 neo-antigenic peptides corresponding to the neo-antigenic mutations.

2019203664 24 May 2019

In one embodiment, the personalized neoplasia vaccine comprises one or more RNA molecules capable of expressing at least 20 neo-antigenic peptides corresponding to the neo-antigenic mutations.

In one embodiment, the personalized neoplasia vaccine comprises neoORF mutations predicted to encode a neoORF polypeptide having a Kd of  $\leq 500$  nM.

In another embodiment, the personalized neoplasia vaccine comprises missense mutations predicted to encode a polypeptide having a Kd of  $\leq 150$  nM, wherein the native cognate protein has a Kd of  $\geq 1000$  nM or  $\leq 150$  nM.

In one embodiment, the at least 20 neo-antigenic peptides range from about 5 to about 50 amino acids in length. In one embodiment, the at least 20 neo-antigenic peptides range from about 15 to about 35 amino acids in length. In one embodiment, the at least 20 neo-antigenic peptides range from about 18 to about 30 amino acids in length. In one embodiment, the at least 20 neo-antigenic peptides range from about 6 to about 15 amino acids in length. In one embodiment, the at least 20 neo-antigenic peptides are 15, 16, 17, 18, 19, 20, 21, 22, 23, 24, or 25 amino acids in length.

In one embodiment, the administering further includes dividing the produced vaccine into two or more sub-pools; and injecting each of the sub-pools into a different location of the patient. In one embodiment, each of the sub-pools injected into a different location comprises neo-antigenic peptides such that the number of individual peptides in the sub-pool targeting any single patient HLA is one, or as few above one as possible.

In one embodiment, the administering step further includes dividing the produced vaccine into two or more sub-pools, wherein each sub-pool comprises at least five neo-antigenic peptides selected to optimize intra-pool interactions.

25 In one embodiment, optimizing comprises reducing negative interaction among the neo-antigenic peptides in the same pool.

In another aspect, the invention includes a personalized neoplasia vaccine prepared according to the above-described methods.

### Definitions

30 To facilitate an understanding of the present invention, a number of terms and phrases are defined below:

2019203664  
24 May 2019

2019203664

Unless specifically stated or obvious from context, as used herein, the term “about” is understood as within a range of normal tolerance in the art, for example within 2 standard deviations of the mean. About can be understood as within 50%, 45%, 40%, 35%, 30%, 25%, 20%, 15%, 10%, 9%, 8%, 7%, 6%, 5%, 4%, 3%, 2%, 1%, 0.5%, 0.1%, 0.05%, or 0.01% of the stated value. Unless otherwise clear from context, all numerical values provided herein are modified by the term about.

By “agent” is meant any small molecule chemical compound, antibody, nucleic acid molecule, or polypeptide, or fragments thereof.

By “ameliorate” is meant decrease, suppress, attenuate, diminish, arrest, or stabilize the development or progression of a disease (e.g., a neoplasia, tumor, etc.).

By “alteration” is meant a change (increase or decrease) in the expression levels or activity of a gene or polypeptide as detected by standard art known methods such as those described herein. As used herein, an alteration includes a 10% change in expression levels, preferably a 25% change, more preferably a 40% change, and most preferably a 50% or greater change in expression levels.

By “analog” is meant a molecule that is not identical, but has analogous functional or structural features. For example, a tumor specific neo-antigen polypeptide analog retains the biological activity of a corresponding naturally-occurring tumor specific neo-antigen polypeptide, while having certain biochemical modifications that enhance the analog's function relative to a naturally-occurring polypeptide. Such biochemical modifications could increase the analog's protease resistance, membrane permeability, or half-life, without altering, for example, ligand binding. An analog may include an unnatural amino acid.

25 The phrase “combination therapy” embraces the administration of a pooled sample of neoplasia/tumor specific neo-antigens and one or more additional therapeutic agents as part of a specific treatment regimen intended to provide a beneficial (additive or synergistic) effect from the co-action of these therapeutic agents. The beneficial effect of the combination includes, but is not limited to, pharmacokinetic or pharmacodynamic co-action resulting from the combination of therapeutic agents. Administration of these therapeutic agents in combination typically is carried out over a defined time period (usually minutes, hours, days, or weeks depending upon  
30 the combination selected). “Combination therapy” is intended to embrace administration of these therapeutic agents in a sequential manner, that is, wherein each therapeutic agent is

administered at a different time, as well as administration of these therapeutic agents, or at least two of the therapeutic agents, in a substantially simultaneous manner. Substantially simultaneous administration can be accomplished, for example, by administering to the subject a single capsule having a fixed ratio of each therapeutic agent or in multiple, single capsules for each of the therapeutic agents. For example, one combination of the present invention may comprise a pooled sample of tumor specific neo-antigens and at least one additional therapeutic agent (e.g., a chemotherapeutic agent, an anti-angiogenesis agent, an immunosuppressive agent, an anti-inflammatory agent, and the like) at the same or different times or they can be formulated as a single, co-formulated pharmaceutical composition comprising the two compounds. As another example, a combination of the present invention (e.g., a pooled sample of tumor specific neo-antigens and at least one additional therapeutic agent) may be formulated as separate pharmaceutical compositions that can be administered at the same or different time. Sequential or substantially simultaneous administration of each therapeutic agent can be effected by any appropriate route including, but not limited to, oral routes, intravenous routes, sub-cutaneous routes, intramuscular routes, direct absorption through mucous membrane tissues (e.g., nasal, mouth, vaginal, and rectal), and ocular routes (e.g., intravitreal, intraocular, etc.). The therapeutic agents can be administered by the same route or by different routes. For example, one component of a particular combination may be administered by intravenous injection while the other component(s) of the combination may be administered orally. The components may be administered in any therapeutically effective sequence.

The phrase "combination" embraces groups of compounds or non-drug therapies useful as part of a combination therapy.

Where any or all of the terms "comprise", "comprises", "comprised" or "comprising" are used in this specification (including the claims) they are to be interpreted as specifying the presence of the stated features, integers, steps or components, but not precluding the presence of one or more other features, integers, steps or components.

The discussion of documents, acts, materials, devices, articles and the like is included in this specification solely for the purpose of providing a context for the present invention. It is not suggested or represented that any or all of these matters formed part of the prior art base or were common general knowledge in the field relevant to the present invention as it existed before the priority date of each claim of this application.

By “control” is meant a standard or reference condition.

By “disease” is meant any condition or disorder that damages or interferes with the normal function of a cell, tissue, or organ.

2019203664  
24 May 2019

2019203664

By “effective amount” is meant the amount required to ameliorate the symptoms of a disease (e.g., a neoplasia/tumor) relative to an untreated patient. The effective amount of active compound(s) used to practice the present invention for therapeutic treatment of a disease varies depending upon the manner of administration, the age, body weight, and general health of the subject. Ultimately, the attending physician or veterinarian will decide the appropriate amount and dosage regimen. Such amount is referred to as an “effective” amount.

By “fragment” is meant a portion of a polypeptide or nucleic acid molecule. This portion contains, preferably, at least 5%, 10%, 20%, 30%, 40%, 50%, 60%, 70%, 80%, or 90% of the entire length of the reference nucleic acid molecule or polypeptide. A fragment may contain 5, 10, 20, 30, 40, 50, 60, 70, 80, 90, or 100, 200, 300, 400, 500, 600, 700, 800, 900, 1000 or more nucleotides or amino acids.

“Hybridization” means hydrogen bonding, which may be Watson-Crick, Hoogsteen or reversed Hoogsteen hydrogen bonding, between complementary nucleobases. For example, adenine and thymine are complementary nucleobases that pair through the formation of hydrogen bonds.

By “inhibitory nucleic acid” is meant a double-stranded RNA, siRNA, shRNA, or antisense RNA, or a portion thereof, or a mimetic thereof, that when administered to a mammalian cell results in a decrease (e.g., by 10%, 25%, 50%, 75%, or even 90-100%) in the expression of a target gene. Typically, a nucleic acid inhibitor comprises at least a portion of a target nucleic acid molecule, or an ortholog thereof, or comprises at least a portion of the complementary strand of a target nucleic acid molecule. For example, an inhibitory nucleic acid molecule comprises at least a portion of any or all of the nucleic acids delineated herein.

By “isolated polynucleotide” is meant a nucleic acid (e.g., a DNA) that is free of the genes which, in the naturally-occurring genome of the organism—or in the genomic DNA of a neoplasia/tumor derived from the organism—the nucleic acid molecule of the invention is derived. The term therefore includes, for example, a recombinant DNA (e.g., DNA coding for a neoORF, read-through, or InDel derived polypeptide identified in a patient’s tumor) that is incorporated into a vector; into an autonomously replicating plasmid or virus; or into the genomic DNA of a prokaryote or eukaryote; or that exists as a separate molecule (for example, a cDNA or a genomic or cDNA fragment produced by PCR or restriction endonuclease digestion) independent of other sequences. In addition, the term includes an RNA molecule that is

25

30

2019203664 24 May 2019

transcribed from a DNA molecule, as well as a recombinant DNA that is part of a hybrid gene encoding additional polypeptide sequence.

By an “isolated polypeptide” is meant a polypeptide of the invention that has been separated from components that naturally accompany it. Typically, the polypeptide is isolated when it is at least 60%, by weight, free from the proteins and naturally-occurring organic molecules with which it is naturally associated. Preferably, the preparation is at least 75%, more preferably at least 90%, and most preferably at least 99%, by weight, a polypeptide of the invention. An isolated polypeptide of the invention may be obtained, for example, by extraction from a natural source, by expression of a recombinant nucleic acid encoding such a polypeptide; or by chemically synthesizing the protein. Purity can be measured by any appropriate method, for example, column chromatography, polyacrylamide gel electrophoresis, or by HPLC analysis.

A “ligand” is to be understood as meaning a molecule which has a structure complementary to that of a receptor and is capable of forming a complex with the receptor. According to the invention, a ligand is to be understood as meaning a peptide or peptide fragment that has a suitable length and suitable binding motifs in its amino acid sequence, so that the peptide or peptide fragment is capable of forming a complex with proteins of MHC class I or MHC class II.

“Mutation” for the purposes of this document means a DNA sequence found in the tumor DNA sample of a patient that is not found in the corresponding normal DNA sample of that same patient. “Mutation” may also refer to patterns in the sequence of RNA from a patient that are not attributable to expected variations based on known information for an individual gene and are reasonably considered to be novel variations in, for example, the splicing pattern of one or more genes that has been specifically altered in the tumor cells of the patient.

25 “Neo-antigen” or “neo-antigenic” means a class of tumor antigens that arises from a tumor-specific mutation(s) which alters the amino acid sequence of genome encoded proteins.

By “neoplasia” is meant any disease that is caused by or results in inappropriately high levels of cell division, inappropriately low levels of apoptosis, or both. For example, cancer is an example of a neoplasia. Examples of cancers include, without limitation, leukemia (e.g., acute leukemia, acute lymphocytic leukemia, acute myelocytic leukemia, acute myeloblastic leukemia, 30 acute promyelocytic leukemia, acute myelomonocytic leukemia, acute monocytic leukemia, acute erythroleukemia, chronic leukemia, chronic myelocytic leukemia, chronic lymphocytic

2019203664 24 May 2019

leukemia), polycythemia vera, lymphoma (e.g., Hodgkin's disease, non-Hodgkin's disease), Waldenstrom's macroglobulinemia, heavy chain disease, and solid tumors such as sarcomas and carcinomas (e.g., fibrosarcoma, myxosarcoma, liposarcoma, chondrosarcoma, osteogenic sarcoma, chordoma, angiosarcoma, endotheliosarcoma, lymphangiosarcoma, lymphangioendotheliosarcoma, synovioma, mesothelioma, Ewing's tumor, leiomyosarcoma, rhabdomyosarcoma, colon carcinoma, pancreatic cancer, breast cancer, ovarian cancer, prostate cancer, squamous cell carcinoma, basal cell carcinoma, adenocarcinoma, sweat gland carcinoma, sebaceous gland carcinoma, papillary carcinoma, papillary adenocarcinomas, cystadenocarcinoma, medullary carcinoma, bronchogenic carcinoma, renal cell carcinoma, hepatoma, bile duct carcinoma, choriocarcinoma, seminoma, embryonal carcinoma, Wilm's tumor, cervical cancer, uterine cancer, testicular cancer, lung carcinoma, small cell lung carcinoma, bladder carcinoma, epithelial carcinoma, glioma, astrocytoma, medulloblastoma, craniopharyngioma, ependymoma, pinealoma, hemangioblastoma, acoustic neuroma, oligodendroglioma, schwannoma, meningioma, melanoma, neuroblastoma, and retinoblastoma). Lymphoproliferative disorders are also considered to be proliferative diseases.

Unless specifically stated or obvious from context, as used herein, the term “or” is understood to be inclusive. Unless specifically stated or obvious from context, as used herein, the terms “a,” “an,” and “the” are understood to be singular or plural.

The term “patient” or “subject” refers to an animal which is the object of treatment, observation, or experiment. By way of example only, a subject includes, but is not limited to, a mammal, including, but not limited to, a human or a non-human mammal, such as a non-human primate, bovine, equine, canine, ovine, or feline.

25 “Pharmaceutically acceptable” refers to approved or approvable by a regulatory agency of the Federal or a state government or listed in the U.S. Pharmacopeia or other generally recognized pharmacopeia for use in animals, including humans.

“Pharmaceutically acceptable excipient, carrier or diluent” refers to an excipient, carrier or diluent that can be administered to a subject, together with an agent, and which does not destroy the pharmacological activity thereof and is nontoxic when administered in doses sufficient to deliver a therapeutic amount of the agent.



2019203664 24 May 2019

A “pharmaceutically acceptable salt” of pooled tumor specific neo-antigens as recited herein may be an acid or base salt that is generally considered in the art to be suitable for use in contact with the tissues of human beings or animals without excessive toxicity, irritation, allergic response, or other problem or complication. Such salts include mineral and organic acid salts of basic residues such as amines, as well as alkali or organic salts of acidic residues such as carboxylic acids. Specific pharmaceutical salts include, but are not limited to, salts of acids such as hydrochloric, phosphoric, hydrobromic, malic, glycolic, fumaric, sulfuric, sulfamic, sulfanilic, formic, toluenesulfonic, methanesulfonic, benzene sulfonic, ethane disulfonic, 2-hydroxyethylsulfonic, nitric, benzoic, 2-acetoxybenzoic, citric, tartaric, lactic, stearic, salicylic, glutamic, ascorbic, pamoic, succinic, fumaric, maleic, propionic, hydroxymaleic, hydroiodic, phenylacetic, alkanolic such as acetic,  $\text{HOOC}-(\text{CH}_2)_n-\text{COOH}$  where  $n$  is 0-4, and the like. Similarly, pharmaceutically acceptable cations include, but are not limited to sodium, potassium, calcium, aluminum, lithium and ammonium. Those of ordinary skill in the art will recognize further pharmaceutically acceptable salts for the pooled tumor specific neo-antigens provided herein, including those listed by *Remington's Pharmaceutical Sciences*, 17th ed., Mack Publishing Company, Easton, PA, p. 1418 (1985). In general, a pharmaceutically acceptable acid or base salt can be synthesized from a parent compound that contains a basic or acidic moiety by any conventional chemical method. Briefly, such salts can be prepared by reacting the free acid or base forms of these compounds with a stoichiometric amount of the appropriate base or acid in an appropriate solvent.

As used herein, the terms “prevent,” “preventing,” “prevention,” “prophylactic treatment,” and the like, refer to reducing the probability of developing a disease or condition in a subject, who does not have, but is at risk of or susceptible to developing a disease or condition.

25 “Primer set” means a set of oligonucleotides that may be used, for example, for PCR. A primer set would consist of at least 2, 4, 6, 8, 10, 12, 14, 16, 18, 20, 30, 40, 50, 60, 80, 100, 200, 250, 300, 400, 500, 600, or more primers.

30 “Proteins or molecules of the major histocompatibility complex (MHC),” “MHC molecules,” “MHC proteins” or “HLA proteins” are to be understood as meaning, in particular, proteins capable of binding peptides resulting from the proteolytic cleavage of protein antigens and representing potential T-cell epitopes, transporting them to the cell surface and presenting

2019203664 24 May 2019

them to specific cells there, in particular naïve T-cells, cytotoxic T-lymphocytes or T-helper cells. The major histocompatibility complex in the genome comprises the genetic region whose gene products are expressed on the cell surface and are important for binding and presenting endogenous and/or foreign antigens, and thus for regulating immunological processes. The major histocompatibility complex is classified into two gene groups coding for different proteins: molecules of MHC class I and MHC class II. The molecules of the two MHC classes are specialized for different antigen sources. The molecules of MHC class I typically present but are not restricted to endogenously synthesized antigens, for example viral proteins and tumor antigens. The molecules of MHC class II present protein antigens originating from exogenous sources, for example bacterial products. The cellular biology and the expression patterns of the two MHC classes are adapted to these different roles.

MHC molecules of class I consist of a heavy chain and a light chain and are capable of binding a peptide of about 8 to 11 amino acids, but usually 9 or 10 amino acids, if this peptide has suitable binding motifs, and presenting it to naïve and cytotoxic T- lymphocytes. The peptide bound by the MHC molecules of class I typically but not exclusively originates from an endogenous protein antigen. The heavy chain of the MHC molecules of class I is preferably an HLA-A, HLA-B or HLA-C monomer, and the light chain is  $\beta$ -2-microglobulin.

MHC molecules of class II consist of an  $\alpha$ -chain and a  $\beta$ -chain and are capable of binding a peptide of about 15 to 24 amino acids if this peptide has suitable binding motifs, and presenting it to T-helper cells. The peptide bound by the MHC molecules of class II usually originates from an extracellular or exogenous protein antigen. The  $\alpha$ -chain and the  $\beta$ -chain are in particular HLA-DR, HLA-DQ and HLA-DP monomers.

Ranges provided herein are understood to be shorthand for all of the values within the range. For example, a range of 1 to 50 is understood to include any number, combination of numbers, or sub-range from the group consisting of 1, 2, 3, 4, 5, 6, 7, 8, 9, 10, 11, 12, 13, 14, 15, 16, 17, 18, 19, 20, 21, 22, 23, 24, 25, 26, 27, 28, 29, 30, 31, 32, 33, 34, 35, 36, 37, 38, 39, 40, 41, 42, 43, 44, 45, 46, 47, 48, 49, or 50, as well as all intervening decimal values between the aforementioned integers such as, for example, 1.1, 1.2, 1.3, 1.4, 1.5, 1.6, 1.7, 1.8, and 1.9. With respect to sub-ranges, “nested sub-ranges” that extend from either end point of the range are specifically contemplated. For example, a nested sub-range of an exemplary range of 1 to 50

2019203664 24 May 2019

may comprise 1 to 10, 1 to 20, 1 to 30, and 1 to 40 in one direction, or 50 to 40, 50 to 30, 50 to 20, and 50 to 10 in the other direction.

A “receptor” is to be understood as meaning a biological molecule or a molecule grouping capable of binding a ligand. A receptor may serve, to transmit information in a cell, a cell formation or an organism. The receptor comprises at least one receptor unit and frequently contains two or more receptor units, where each receptor unit may consist of a protein molecule, in particular a glycoprotein molecule. The receptor has a structure that complements the structure of a ligand and may complex the ligand as a binding partner. Signaling information may be transmitted by conformational changes of the receptor following binding with the ligand on the surface of a cell. According to the invention, a receptor may refer to particular proteins of MHC classes I and II capable of forming a receptor/ligand complex with a ligand, in particular a peptide or peptide fragment of suitable length.

A “receptor/ligand complex” is also to be understood as meaning a “receptor/peptide complex” or “receptor/peptide fragment complex,” in particular a peptide- or peptide fragment-presenting MHC molecule of class I or of class II.

By “reduces” is meant a negative alteration of at least 10%, 25%, 50%, 75%, or 100%.

By “reference” is meant a standard or control condition.

A “reference sequence” is a defined sequence used as a basis for sequence comparison. A reference sequence may be a subset of, or the entirety of, a specified sequence; for example, a  
20 segment of a full-length cDNA or genomic sequence, or the complete cDNA or genomic sequence. For polypeptides, the length of the reference polypeptide sequence will generally be at least about 10-2,000 amino acids, 10-1,500, 10-1,000, 10-500, or 10-100. Preferably, the length of the reference polypeptide sequence may be at least about 10-50 amino acids, more preferably at least about 10-40 amino acids, and even more preferably about 10-30 amino acids, about 10-  
25 20 amino acids, about 15-25 amino acids, or about 20 amino acids. For nucleic acids, the length of the reference nucleic acid sequence will generally be at least about 50 nucleotides, preferably at least about 60 nucleotides, more preferably at least about 75 nucleotides, and even more preferably about 100 nucleotides or about 300 nucleotides or any integer thereabout or there between.

2019203664  
24 May 2019

2019203664

By “specifically binds” is meant a compound or antibody that recognizes and binds a polypeptide of the invention, but which does not substantially recognize and bind other molecules in a sample, for example, a biological sample.

Nucleic acid molecules useful in the methods of the invention include any nucleic acid molecule that encodes a polypeptide of the invention or a fragment thereof. Such nucleic acid molecules need not be 100% identical with an endogenous nucleic acid sequence, but will typically exhibit substantial identity. Polynucleotides having “substantial identity” to an endogenous sequence are typically capable of hybridizing with at least one strand of a double-stranded nucleic acid molecule. . By “hybridize” is meant pair to form a double-stranded molecule between complementary polynucleotide sequences (e.g., a gene described herein), or portions thereof, under various conditions of stringency. (See, e.g., Wahl, G. M. and S. L. Berger (1987) *Methods Enzymol.* 152:399; Kimmel, A. R. (1987) *Methods Enzymol.* 152:507).

For example, stringent salt concentration will ordinarily be less than about 750 mM NaCl and 75 mM trisodium citrate, preferably less than about 500 mM NaCl and 50 mM trisodium citrate, and more preferably less than about 250 mM NaCl and 25 mM trisodium citrate. Low stringency hybridization can be obtained in the absence of organic solvent, e.g., formamide, while high stringency hybridization can be obtained in the presence of at least about 35% formamide, and more preferably at least about 50% formamide. Stringent temperature conditions will ordinarily include temperatures of at least about 30°C, more preferably of at least about 37°C, and most preferably of at least about 42°C. Varying additional parameters, such as hybridization time, the concentration of detergent, e.g., sodium dodecyl sulfate (SDS), and the inclusion or exclusion of carrier DNA, are well known to those skilled in the art. Various levels of stringency are accomplished by combining these various conditions as needed. In a preferred: embodiment, hybridization will occur at 30°C in 750 mM NaCl, 75 mM trisodium citrate, and 1% SDS. In a more preferred embodiment, hybridization will occur at 37° C in 500 mM NaCl, 50 mM trisodium citrate, 1% SDS, 35% formamide, and 100 µg/ml denatured salmon sperm DNA (ssDNA). In a most preferred embodiment, hybridization will occur at 42°C in 250 mM NaCl, 25 mM trisodium citrate, 1% SDS, 50% formamide, and 200 µg/ml ssDNA. Useful variations on these conditions will be readily apparent to those skilled in the art.

For most applications, washing steps that follow hybridization will also vary in stringency. Wash stringency conditions can be defined by salt concentration and by temperature.

2019203664 24 May 2019

As above, wash stringency can be increased by decreasing salt concentration or by increasing temperature. For example, stringent salt concentration for the wash steps will preferably be less than about 30 mM NaCl and 3 mM trisodium citrate, and most preferably less than about 15 mM NaCl and 1.5 mM trisodium citrate. Stringent temperature conditions for the wash steps will ordinarily include a temperature of at least about 25°C, more preferably of at least about 42°C, and even more preferably of at least about 68°C. In a preferred embodiment, wash steps will occur at 25°C in 30 mM NaCl, 3 mM trisodium citrate, and 0.1% SDS. In a more preferred embodiment, wash steps will occur at 42°C in 15 mM NaCl, 1.5 mM trisodium citrate, and 0.1% SDS. In a more preferred embodiment, wash steps will occur at 68°C in 15 mM NaCl, 1.5 mM trisodium citrate, and 0.1% SDS. Additional variations on these conditions will be readily apparent to those skilled in the art. Hybridization techniques are well known to those skilled in the art and are described, for example, in Benton and Davis (*Science* 196:180, 1977); Grunstein and Hogness (*Proc. Natl. Acad. Sci., USA* 72:3961, 1975); Ausubel *et al.* (*Current Protocols in Molecular Biology*, Wiley Interscience, New York, 2001); Berger and Kimmel (*Guide to Molecular Cloning Techniques*, 1987, Academic Press, New York); and Sambrook *et al.*, *Molecular Cloning: A Laboratory Manual*, Cold Spring Harbor Laboratory Press, New York.

By “substantially identical” is meant a polypeptide or nucleic acid molecule exhibiting at least 50% identity to a reference amino acid sequence (for example, any one of the amino acid sequences described herein) or nucleic acid sequence (for example, any one of the nucleic acid sequences described herein). Preferably, such a sequence is at least 60%, more preferably 80% or 85%, and more preferably 90%, 95% or even 99% identical at the amino acid level or nucleic acid to the sequence used for comparison.

Sequence identity is typically measured using sequence analysis software (for example, Sequence Analysis Software Package of the Genetics Computer Group, University of Wisconsin Biotechnology Center, 1710 University Avenue, Madison, Wis. 53705, BLAST, BESTFIT, GAP, or PILEUP/PRETTYBOX programs). Such software matches identical or similar sequences by assigning degrees of homology to various substitutions, deletions, and/or other modifications. Conservative substitutions typically include substitutions within the following groups: glycine, alanine; valine, isoleucine, leucine; aspartic acid, glutamic acid, asparagine, glutamine; serine, threonine; lysine, arginine; and phenylalanine, tyrosine. In an exemplary

2019203664 24 May 2019

approach to determining the degree of identity, a BLAST program may be used, with a probability score between  $e^{-3}$  and  $e^{-100}$  indicating a closely related sequence.

A “T-cell epitope” is to be understood as meaning a peptide sequence that can be bound by MHC molecules of class I or II in the form of a peptide-presenting MHC molecule or MHC complex and then, in this form, be recognized and bound by naïve T-cells, cytotoxic T-lymphocytes or T-helper cells.

As used herein, the terms “treat,” “treated,” “treating,” “treatment,” and the like refer to reducing or ameliorating a disorder and/or symptoms associated therewith (e.g., a neoplasia or tumor). It will be appreciated that, although not precluded, treating a disorder or condition does not require that the disorder, condition, or symptoms associated therewith be completely eliminated.

The term “therapeutic effect” refers to some extent of relief of one or more of the symptoms of a disorder (e.g., a neoplasia or tumor) or its associated pathology. “Therapeutically effective amount” as used herein refers to an amount of an agent which is effective, upon single or multiple dose administration to the cell or subject, in prolonging the survivability of the patient with such a disorder, reducing one or more signs or symptoms of the disorder, preventing or delaying, and the like beyond that expected in the absence of such treatment.

“Therapeutically effective amount” is intended to qualify the amount required to achieve a therapeutic effect. A physician or veterinarian having ordinary skill in the art can readily determine and prescribe the “therapeutically effective amount” (e.g., ED50) of the pharmaceutical composition required. For example, the physician or veterinarian could start doses of the compounds of the invention employed in a pharmaceutical composition at levels lower than that required in order to achieve the desired therapeutic effect and gradually increase the dosage until the desired effect is achieved.

25           The pharmaceutical compositions typically should provide a dosage of from about 0.0001 mg to about 200 mg of compound per kilogram of body weight per day. For example, dosages for systemic administration to a human patient can range from 0.01-10  $\mu\text{g}/\text{kg}$ , 20-80  $\mu\text{g}/\text{kg}$ , 5-50  $\mu\text{g}/\text{kg}$ , 75-150  $\mu\text{g}/\text{kg}$ , 100-500  $\mu\text{g}/\text{kg}$ , 250-750  $\mu\text{g}/\text{kg}$ , 500-1000  $\mu\text{g}/\text{kg}$ , 1-10 mg/kg, 5-50 mg/kg, 25-75 mg/kg, 50-100 mg/kg, 100-250 mg/kg, 50-100 mg/kg, 250-500 mg/kg, 500-750 mg/kg, 30 750-1000 mg/kg, 1000-1500 mg/kg, 1500-2000 mg/kg, 5 mg/kg, 20 mg/kg, 50 mg/kg, 100 mg/kg, of 200 mg/kg. Pharmaceutical dosage unit forms are prepared to provide from about

2019203664  
24 May 2019

0.001 mg to about 5000 mg, for example from about 100 to about 2500 mg of the compound or a combination of essential ingredients per dosage unit form.

A “vaccine” is to be understood as meaning a composition for generating immunity for the prophylaxis and/or treatment of diseases (e.g., neoplasia/tumor). Accordingly, vaccines are medicaments which comprise antigens and are intended to be used in humans or animals for generating specific defense and protective substance by vaccination.

The recitation of a listing of chemical groups in any definition of a variable herein includes definitions of that variable as any single group or combination of listed groups. The recitation of an embodiment for a variable or aspect herein includes that embodiment as any single embodiment or in combination with any other embodiments or portions thereof.

Any compositions or methods provided herein can be combined with one or more of any of the other compositions and methods provided herein.

### **BRIEF DESCRIPTION OF THE DRAWINGS**

The above-mentioned and other features and advantages of the present disclosure will be better understood when reading the following detailed description taken together with the following drawings in which:

Figure 1 depicts a flow process for making a personalized cancer vaccine according to an exemplary embodiment of the invention.

Figure 2 shows a flow process for pre-treatment steps for generating a cancer vaccine for a melanoma patient according to an exemplary embodiment of the invention.

Figure 3 is a flowchart depicting an approach for addressing an initial patient population study according to an exemplary embodiment of the invention. Five patients may be treated in the first cohort at an anticipated safe dose level. If fewer than two of these five patients develop a dose limiting toxicity at, or prior to, the primary safety endpoint, then 10 more patients may be recruited at that dose level to expand the analysis of the patient population (e.g., to assess efficacy, safety, etc.). If two or more dose limiting toxicities (DLTs) are observed, then the dose of poly-ICLC may be reduced by 50% and five additional patients may be treated. If fewer than two of these five patients develop a dose limiting toxicity, then 10 more patients may be recruited at that dose level. However, if two or more patients at the reduced poly-ICLC level develop a DLT, then the study will be stopped.

Figures 4A and 4B show examples of different types of discrete mutations and neoORFs, respectively.

Figure 5 illustrates an immunization schedule based on a prime boost strategy according to an exemplary embodiment of the present invention. Multiple immunizations may occur over the first ~3 weeks to maintain an early high antigen exposure during the priming phase of immune response. Patients may then be rested for eight weeks to allow memory T cells to develop and these T cells will then be boosted in order to maintain a strong ongoing response.

Figure 6 shows a time line indicating the primary immunological endpoint according to an exemplary aspect of the invention.

Figure 7 illustrates a time line for administering a co-therapy with checkpoint blockade antibodies to evaluate the combination of relief of local immune suppression coupled with the stimulation of new immunity according to an exemplary embodiment of the invention. As shown in the scheme, patients who enter as appropriate candidates for checkpoint blockade therapy, e.g., anti-PDL1 as shown here, may be entered and immediately treated with antibody, while the vaccine is being prepared. Patients may then be vaccinated. Checkpoint blockade antibody dosing can be continued or possibly deferred while the priming phase of vaccination occurs.

Figure 8 is a table that shows the ranking assignments for different neo-antigenic mutations according to an exemplary embodiment of the invention.

Figure 9 shows a schematic depicting drug product processing of individual neo-antigenic peptides into pools of 4 subgroups according to an exemplary embodiment of the invention.

25 Figure 10 shows a schematic representation of a strategy to systematically discover tumor neoantigens according to an exemplary embodiment of the invention. Tumor specific mutations in cancer samples may be detected using whole-exome (WES) or whole-genome sequencing (WGS) and identified through the application of mutation calling algorithms (e.g., Mutect). Subsequently, candidate neoepitopes may be predicted using well-validated algorithms (e.g., NetMHCpan) and their identification may be refined by experimental validation for peptide-HLA binding and by confirmation of gene expression at the RNA level. These candidate  
30 neoantigens may be subsequently tested for their ability to stimulate tumor-specific T cell responses.



24 May 2019

2019203664

Figures 11A-C show the frequency of classes of point mutations that have the potential to generate neoantigens in chronic lymphocytic leukemia (CLL). Analysis of WES and WGS data generated from 91 CLL cases reveals that (A) missense mutations are the most frequent class of the somatic alterations with the potential to generate neo-epitopes, while (B) frameshift insertions and deletions and (C) splice-site mutations constitute less common events.

Figures 12A-D depict the application of the NetMHCpan prediction algorithm to functionally-defined neoepitopes and CLL cases. FIG. 12 A shows the predicted binding ( $IC_{50}$ ) to their known restricting HLA allele of 33 functionally identified cancer neoepitopes reported in literature tested by NetMHCpan, sorted on the basis of predicted binding affinity. FIG. 12B shows the distribution of the number of predicted peptides with HLA binding affinity  $< 150$  nM (black) and 150-500 nM (grey) across 31 CLL patients with available HLA typing information. FIG. 12C shows a graph comparing the predicted binding ( $IC_{50} < 500$  nM by NetMHCpan) of peptides from 4 patients with the experimentally determined binding affinity for HLA-A and -B allele binding using a competitive MHC I allele-binding assay with synthesized peptides. The percent of predicted peptides with evidence of experimental binding ( $IC_{50} < 500$  nM) are indicated. FIG. 12D shows that from 26 CLL patients for which HLA typing and Affymetrix U133 2.0+ gene expression data were available, the distribution of gene expression was examined for all somatically mutated genes ( $n=347$ ), and for the subset of gene mutations encoding neoepitopes with predicted HLA binding scores of  $IC_{50} < 500$  nM ( $n=180$ ). No-low: genes within the lowest quartile expression; medium: genes within the 2 middle quartiles of expression; and high: genes within the highest quartile of expression.

Figures 13A-B show the same data as in Figure 12D but separately for 9-mer (FIG. 13A) and 10-mer peptides (FIG. 13B). In each case, percentages of peptides with predicted  $IC_{50} < 150$  nM and 150-500 nM, with evidence of experimental binding are indicated.

25 Figures 14A-C depict that mutations in *ALMS1* and *C6ORF89* in Pt 1 generate immunogenic peptides. FIG. 14A shows that 25 missense mutations were identified in Pt 1 CLL cells from which 30 peptides from 13 mutations were predicted to bind to Pt 1's MHC class I alleles. A total of 14 peptides from 9 mutations were experimentally confirmed as HLA-binding. Post-transplant T cells (7 yrs) from Pt 1 were stimulated weekly *ex vivo* for 4 weeks with 5 pools  
30 of 6 mutated peptides with similar predicted HLA binding, per pool, and subsequently tested by IFN- $\gamma$  ELISPOT assay. FIG. 14B shows that increased IFN- $\gamma$  secretion by T cells was detected

24 May 2019

2019203664

against Pool 2 peptides. Negative control - Irrelevant Tax peptide; positive control - PHA. FIG. 14C shows that of Pool 2 peptides, Pt 1 T cells were reactive to mutated *ALMS1* and *C6ORF89* peptides (right panel; averaged results from duplicate wells are displayed). Left panel-The predicted and experimental IC50 scores (nM) of mutated and wildtype *ALMS1* and *C6ORF89* peptides.

Figure 15 illustrates that the sequence context around the sites of mutations in *FNDC3B*, *C6orf89* and *ALMS1* lack evolutionary conservation. The neoepitopes generated from each of the genes are boxed. Red- conserved amino acids (aa) in all 4 species; blue- conserved aa in at least 2 of 4 species; black –absent conservation across species.

Figure 16 shows localization of somatic mutations reported in *FNDC3B*, *C6orf89* and *ALMS1* genes. Missense mutations identified in *FNDC3B*, *C6orf89* and *ALMS1* in CLL Pts 1 and 2 compared to previously reported somatic mutations in these genes (COSMIC database) across cancers.

Figure 17 shows that mutated *FNDC3B* generates a naturally immunogenic neoepitope in Pt 2. FIG. 17A shows 26 missense mutations were identified in Pt 2 CLL cells from which 37 peptides from 16 mutations were predicted to bind to Pt 2's MHC class I alleles. A total of 18 peptides from 12 mutations were experimentally confirmed to bind. Post-transplant T cells (~3 yrs) from Pt 2 were stimulated with autologous DCs or B cells pulsed with 3 pools of experimentally validated binding mutated peptides (18 peptides total) for 2 weeks *ex vivo* (See table S6). FIG. 17B shows increased IFN- $\gamma$  secretion was detected by ELISPOT assay in T cells stimulated with Pool 1 peptides. FIG. 17C shows that of Pool 1 peptides, increased IFN- $\gamma$  secretion was detected against the mut-*FNDC3B* peptide (bottom panel; averaged results from duplicated wells are displayed). Top panel - Predicted and experimental IC50 scores of mut- and wt- *FNDC3B* peptides. FIG. 17D illustrates that T cells reactive to mut-*FNDC3B* demonstrate specificity to the mutated epitope but not the corresponding wildtype peptide (concentrations: 0.1-10  $\mu\text{g/ml}$ ), and are polyfunctional, secreting IFN- $\gamma$ , GM-CSF and IL-2 (Tukey post-hoc tests from two-way ANOVA modeling for comparisons between T cell reactivity against mut vs wt peptide). FIG. 17E shows that Mut-*FNDC3B*-specific T cells are reactive in a class I-restricted manner (left), and recognize an endogenously processed and presented form of mutated *FNDC3B*, since they recognized HLA-A2 APCs transfected with a plasmid encoding a minigene of 300bp encompassing the *FNDC3B* mutation (right) (two-sided *t* test). Top right - Western blot

2019203664 24 May 2019

analysis-confirming expression of minigenes encoding mut- and wt- *FNDC3B*. FIG. 17F shows that T cells recognizing the mut-*FNDC3B* epitope as detected by HLA-A2<sup>+</sup>/mut *FNDC3B* tetramers are more frequently detected in T cells in Pt 2 compared to T cells from a normal donor. FIG. 17G shows expression of *FNDC3B* (based on Affymetrix U133Plus2 array data) in Pt 2 (triangle), CLL-B cells (n=182) and normal CD19<sup>+</sup> B cells from healthy adult volunteers (n=24).

Figure 18 illustrates kinetics of the mut-*FNDC3B* specific T cell response in relation to the transplant course. FIG. 18 shows molecular tumor burden was measured in Pt 2 using a patient tumor-specific Taqman PCR assay based on the clonotypic IgH sequence at serial time points before and after HSCT (top panel). Middle panel- Detection of mut-*FNDC3B* reactive T cells in comparison to wt-*FNDC3B* or irrelevant peptides from peripheral blood before and after allo-HSCT by IFN- $\gamma$  ELISPOT following stimulation with peptide-pulsed autologous B cells. The number of IFN- $\gamma$ -secreting spots per cells at each time point was measured in triplicate (Welch *t* test; mut vs. wt). Inset – IFN- $\gamma$  secretion of T cells from 6 months post-HSCT (purple) compared to 32 months post-HSCT (red) following exposure to APCs pulsed with 0.1-10  $\mu$ g/ml (log scale) mut-*FNDC3B* peptide. Bottom panel - Detection of mut-*FNDC3B*-specific TCR V $\beta$ 11 cells by nested clone-specific CDR3 PCR before and after HSCT in peripheral blood of Pt 2 (See supplementary methods). Triangles – time points at which a sample was tested; NA- no amplification; black: amplification detected, where ‘+’ indicates detectable amplification up to 2-fold and ‘++’ indicates more than 2-fold greater amplification than the median level of all samples with detectable expression of the clone-specific V $\beta$ 11 sequence.

Figures 19A-D show the design of mut-*FNDC3B* specific TCR V $\beta$  specific primers in Pt 2. FIG. 19A shows mut-*FNDC3B* specific T cells detected and isolated from Pt 2 PBMCs 6 months following HSCT using an IFN-  $\gamma$  catch assay. FIG. 19B shows RNA from *FNDC3B*-reactive T cells expressed TCR V $\beta$ 11, generating an amplicon of 350bp in length. FIG. 19C shows V $\beta$ 11-specific real time primers were designed based on the sequence of the mut-*FNDC3B* clone-specific CDR3 rearrangement, such that the quantitative PCR probe was positioned in the region of junctional diversity (orange). FIG. 19D shows *FNDC3B*-reactive T cells were monoclonal for V $\beta$ 11, as detected by spectratyping.

Figures 20A-G illustrate the application of the neoantigen discovery pipeline across cancers. FIG. 20A shows the comparison of overall somatic mutation rate detected across

2019203664 24 May 2019

cancers by massively parallel sequencing. Red-CLL; blue-clear cell renal carcinoma (RCC) and green- melanoma. LSCC: Lung squamous cell carcinoma, Lung AdCa: Lung adenocarcinoma, ESO AdCa: Esophageal adenocarcinoma, DLBCL: Diffused large B- cell lymphoma, GBM: Glioblastoma, Papillary RCC: Papillary renal cell carcinoma, Clear Cell RCC: Clear cell renal carcinoma, CLL: Chronic lymphocytic leukemia, AML: Acute myeloid leukemia. Distribution of FIG. 20B shows the number of missense, frameshift and splice-site mutations per case in melanoma, clear cell RCC and CLL, FIG. 20C shows the average neoORF length generated per sample and FIG. 20D shows predicted neopeptides with  $IC_{50} < 150$  nM (dashed lines) and  $< 500$  nM (solid lines) generated from missense and frameshift mutations. FIGS. 20E depicts the distributions (shown by box plot) of the number of missense, frameshift and splice-site mutations per case across 13 cancers. FIG. 20F shows the summed neoORF length generated per sample. FIG. 20G shows the predicted neopeptides with  $IC_{50} < 150$  nM and with  $< 500$  nM generated from missense and frameshift mutations,. For all box plots, the left and right ends of the boxes represent the 25th and 75th percentile values, respectively, while the segment in the middle is the median. The left and right extremes of the bars extend to the minimum and maximum values..

### DETAILED DESCRIPTION OF THE INVENTION

The present invention relates to personalized strategies for the treatment of neoplasia, and more particularly tumors, by administering a therapeutically effective amount of a pharmaceutical composition (e.g., a cancer vaccine) comprising a plurality of neoplasia/tumor specific neo-antigens to a subject (e.g., a mammal such as a human). As described in more detail below, the present invention is based, at least in part, on the discovery that whole genome/exome sequencing may be used to identify all, or nearly all, mutated neo-antigens that are uniquely present in a neoplasia/tumor of an individual patient, and that this collection of mutated neo-antigens may be analyzed to identify a specific, optimized subset of neo-antigens for use as a personalized cancer vaccine for treatment of the patient's neoplasia/tumor. For example, as shown in FIG. 1, a population of neoplasia/tumor specific neo-antigens may be identified by sequencing the neoplasia/tumor and normal DNA of each patient to identify tumor-specific mutations, and determining the patient's HLA allotype. The population of neoplasia/tumor specific neo-antigens and their cognate native antigens may then be subject to bioinformatic analysis using validated algorithms to predict which tumor-specific mutations create epitopes

2019203664 24 May 2019

that could bind to the patient's HLA allotype, and in particular which tumor-specific mutations create epitopes that could bind to the patient's HLA allotype more effectively than the cognate native antigen. Based on this analysis, a plurality of peptides corresponding to a subset of these mutations may be designed and synthesized for each patient, and pooled together for use as a cancer vaccine in immunizing the patient. The neo-antigen peptides may be combined with an adjuvant (e.g., poly-ICLC) or another anti-neoplastic agent. Without being bound by theory, these neo-antigens are expected to bypass central thymic tolerance (thus allowing stronger anti-tumor T cell response), while reducing the potential for autoimmunity (e.g., by avoiding targeting of normal self-antigens).

The immune system can be classified into two functional subsystems: the innate and the acquired immune system. The innate immune system is the first line of defense against infections, and most potential pathogens are rapidly neutralized by this system before they can cause, for example, a noticeable infection. The acquired immune system reacts to molecular structures, referred to as antigens, of the intruding organism. There are two types of acquired immune reactions, which include the humoral immune reaction and the cell-mediated immune reaction. In the humoral immune reaction, antibodies secreted by B cells into bodily fluids bind to pathogen-derived antigens, leading to the elimination of the pathogen through a variety of mechanisms, e.g. complement-mediated lysis. In the cell-mediated immune reaction, T-cells capable of destroying other cells are activated. For example, if proteins associated with a disease are present in a cell, they are fragmented proteolytically to peptides within the cell. Specific cell proteins then attach themselves to the antigen or peptide formed in this manner and transport them to the surface of the cell, where they are presented to the molecular defense mechanisms, in particular T-cells, of the body. Cytotoxic T cells recognize these antigens and kill the cells that harbor the antigens.

25 The molecules that transport and present peptides on the cell surface are referred to as proteins of the major histocompatibility complex (MHC). MHC proteins are classified into two types, referred to as MHC class I and MHC class II. The structures of the proteins of the two MHC classes are very similar; however, they have very different functions. Proteins of MHC class I are present on the surface of almost all cells of the body, including most tumor cells.

30 MHC class I proteins are loaded with antigens that usually originate from endogenous proteins or from pathogens present inside cells, and are then presented to naïve or cytotoxic T-lymphocytes

2019203664 24 May 2019

(CTLs). MHC class II proteins are present on dendritic cells, B- lymphocytes, macrophages and other antigen-presenting cells. They mainly present peptides, which are processed from external antigen sources, i.e. outside of the cells, to T-helper (Th) cells. Most of the peptides bound by the MHC class I proteins originate from cytoplasmic proteins produced in the healthy host cells of an organism itself, and do not normally stimulate an immune reaction. Accordingly, cytotoxic T-lymphocytes that recognize such self-peptide-presenting MHC molecules of class I are deleted in the thymus (central tolerance) or, after their release from the thymus, are deleted or inactivated, i.e. tolerized (peripheral tolerance). MHC molecules are capable of stimulating an immune reaction when they present peptides to non-tolerized T-lymphocytes. Cytotoxic T-lymphocytes have both T-cell receptors (TCR) and CD8 molecules on their surface. T-Cell receptors are capable of recognizing and binding peptides complexed with the molecules of MHC class I. Each cytotoxic T-lymphocyte expresses a unique T-cell receptor which is capable of binding specific MHC/peptide complexes.

The peptide antigens attach themselves to the molecules of MHC class I by competitive affinity binding within the endoplasmic reticulum, before they are presented on the cell surface. Here, the affinity of an individual peptide antigen is directly linked to its amino acid sequence and the presence of specific binding motifs in defined positions within the amino acid sequence. If the sequence of such a peptide is known, it is possible to manipulate the immune system against diseased cells using, for example, peptide vaccines.

One of the critical barriers to developing curative and tumor-specific immunotherapy is the identification and selection of highly specific and restricted tumor antigens to avoid autoimmunity. Tumor neo-antigens, which arise as a result of genetic change (e.g., inversions, translocations, deletions, missense mutations, splice site mutations, etc.) within malignant cells, represent the most tumor-specific class of antigens. Neo-antigens have rarely been used in cancer vaccines due to technical difficulties in identifying them, selecting optimized neo-antigens, and producing neo-antigens for use in a vaccine. According to the present invention, these problems may be addressed by:

- identifying all, or nearly all, mutations in the neoplasia/tumor at the DNA level using whole genome, whole exome (e.g., only captured exons), or RNA sequencing of tumor versus matched germline samples from each patient;

2019203664  
24 May 2019

- analyzing the identified mutations with one or more peptide-MHC binding prediction algorithms to generate a plurality of candidate neo-antigen T cell epitopes that are expressed within the neoplasia/tumor and may bind patient HLA alleles; and
- synthesizing the plurality of candidate neo-antigen peptides selected from the sets of all neoORF peptides and predicted binding peptides for use in a cancer vaccine.

For example, translating sequencing information into a therapeutic vaccine may include:

(1) *Prediction of personal mutated peptides that can bind to HLA molecules of the individual.* Efficiently choosing which particular mutations to utilize as immunogen requires identification of the patient HLA type and the ability to predict which mutated peptides would efficiently bind to the patient's HLA alleles. Recently, neural network based learning approaches with validated binding and non-binding peptides have advanced the accuracy of prediction algorithms for the major HLA-A and -B alleles.

(2) *Formulating the drug as a multi-epitope vaccine of long peptides.* Targeting as many mutated epitopes as practically possible takes advantage of the enormous capacity of the immune system, prevents the opportunity for immunological escape by down-modulation of a particular immune targeted gene product, and compensates for the known inaccuracy of epitope prediction approaches. Synthetic peptides provide a particularly useful means to prepare multiple immunogens efficiently and to rapidly translate identification of mutant epitopes to an effective vaccine. Peptides can be readily synthesized chemically and easily purified utilizing reagents free of contaminating bacteria or animal substances. The small size allows a clear focus on the mutated region of the protein and also reduces irrelevant antigenic competition from other components (unmutated protein or viral vector antigens).

(3) *Combination with a strong vaccine adjuvant.* Effective vaccines require a strong adjuvant to initiate an immune response. As described below, poly-ICLC, an agonist of TLR3 and the RNA helicase –domains of MDA5 and RIG3, has shown several desirable properties for a vaccine adjuvant. These properties include the induction of local and systemic activation of immune cells *in vivo*, production of stimulatory chemokines and cytokines, and stimulation of antigen-presentation by DCs. Furthermore, poly-ICLC can induce durable CD4<sup>+</sup> and CD8<sup>+</sup> responses in humans. Importantly, striking similarities in the upregulation of transcriptional and signal transduction pathways were seen in subjects vaccinated with poly-ICLC and in volunteers who had received the highly effective, replication-competent yellow fever vaccine. Furthermore,

2019203664 24 May 2019

>90% of ovarian carcinoma patients immunized with poly-ICLC in combination with a NY-ESO-1 peptide vaccine (in addition to Montanide) showed induction of CD4<sup>+</sup> and CD8<sup>+</sup> T cell, as well as antibody responses to the peptide in a recent phase 1 study. At the same time, poly-ICLC has been extensively tested in more than 25 clinical trials to date and exhibited a relatively benign toxicity profile.

The above-described advantages of the invention are described in further detail below.

### **Identification of Tumor Specific Neo-antigen Mutations**

The present invention is based, at least in part, on the ability to identify all, or nearly all, of the mutations within a neoplasia/tumor (e.g., translocations, inversions, large and small deletions and insertions, missense mutations, splice site mutations, etc.). In particular, these mutations are present in the genome of neoplasia/tumor cells of a subject, but not in normal tissue from the subject. Such mutations are of particular interest if they lead to changes that result in a protein with an altered amino acid sequence that is unique to the patient's neoplasia/tumor (e.g., a neo-antigen). For example, useful mutations may include: (1) non-synonymous mutations leading to different amino acids in the protein; (2) read-through mutations in which a stop codon is modified or deleted, leading to translation of a longer protein with a novel tumor-specific sequence at the C-terminus; (3) splice site mutations that lead to the inclusion of an intron in the mature mRNA and thus a unique tumor-specific protein sequence; (4) chromosomal rearrangements that give rise to a chimeric protein with tumor-specific sequences at the junction of 2 proteins (i.e., gene fusion); (5) frameshift mutations or deletions that lead to a new open reading frame with a novel tumor-specific protein sequence; and the like. Peptides with mutations or mutated polypeptides arising from, for example, splice-site, frameshift, read-through, or gene fusion mutations in tumor cells may be identified by sequencing DNA, RNA or protein in tumor versus normal cells.

Also within the scope of the inventions is personal neo-antigen peptides derived from common tumor driver genes and may further include previously identified tumor specific mutations. For example, known common tumor driver genes and tumor mutations in common tumor driver genes may be found on the world wide web at ([www](http://www.sanger.ac.uk/cosmic))sanger.ac.uk/cosmic.

A number of initiatives are currently underway to obtain sequence information directly from millions of individual molecules of DNA or RNA in parallel. Real-time single molecule



2019203664 24 May 2019

sequencing-by-synthesis technologies rely on the detection of fluorescent nucleotides as they are incorporated into a nascent strand of DNA that is complementary to the template being sequenced. In one method, oligonucleotides 30-50 bases in length are covalently anchored at the 5' end to glass cover slips. These anchored strands perform two functions. First, they act as capture sites for the target template strands if the templates are configured with capture tails complementary to the surface-bound oligonucleotides. They also act as primers for the template directed primer extension that forms the basis of the sequence reading. The capture primers function as a fixed position site for sequence determination using multiple cycles of synthesis, detection, and chemical cleavage of the dye-linker to remove the dye. Each cycle consists of adding the polymerase/labeled nucleotide mixture, rinsing, imaging and cleavage of dye. In an alternative method, polymerase is modified with a fluorescent donor molecule and immobilized on a glass slide, while each nucleotide is color-coded with an acceptor fluorescent moiety attached to a gamma-phosphate. The system detects the interaction between a fluorescently-tagged polymerase and a fluorescently modified nucleotide as the nucleotide becomes incorporated into the de novo chain. Other sequencing-by-synthesis technologies also exist.

Preferably, any suitable sequencing-by-synthesis platform can be used to identify mutations. Four major sequencing-by-synthesis platforms are currently available: the Genome Sequencers from Roche/454 Life Sciences, the HiSeq Analyzer from Illumina/Solexa, the SOLiD system from Applied BioSystems, and the Heliscope system from Helicos Biosciences. Sequencing-by-synthesis platforms have also been described by Pacific Biosciences and VisiGen Biotechnologies. Each of these platforms can be used in the methods of the invention. In some embodiments, a plurality of nucleic acid molecules being sequenced is bound to a support (e.g., solid support). To immobilize the nucleic acid on a support, a capture sequence/universal priming site can be added at the 3' and/or 5' end of the template. The nucleic acids may be bound to the support by hybridizing the capture sequence to a complementary sequence covalently attached to the support. The capture sequence (also referred to as a universal capture sequence) is a nucleic acid sequence complementary to a sequence attached to a support that may dually serve as a universal primer.

As an alternative to a capture sequence, a member of a coupling pair (such as, e.g., antibody/antigen, receptor/ligand, or the avidin-biotin pair as described in, e.g., U.S. Patent Application No. 2006/0252077) may be linked to each fragment to be captured on a surface

2019203664 24 May 2019

coated with a respective second member of that coupling pair. Subsequent to the capture, the sequence may be analyzed, for example, by single molecule detection/sequencing, e.g., as described in the Examples and in U.S. Patent No. 7,283,337, including template-dependent sequencing-by-synthesis. In sequencing-by-synthesis, the surface-bound molecule is exposed to a plurality of labeled nucleotide triphosphates in the presence of polymerase. The sequence of the template is determined by the order of labeled nucleotides incorporated into the 3' end of the growing chain. This can be done in real time or in a step-and-repeat mode. For real-time analysis, different optical labels to each nucleotide may be incorporated and multiple lasers may be utilized for stimulation of incorporated nucleotides.

Any cell type or tissue may be utilized to obtain nucleic acid samples for use in the sequencing methods described herein. In a preferred embodiment, the DNA or RNA sample is obtained from a neoplasia/tumor or a bodily fluid, e.g., blood, obtained by known techniques (e.g. venipuncture) or saliva. Alternatively, nucleic acid tests can be performed on dry samples (e.g. hair or skin).

A variety of methods are available for detecting the presence of a particular mutation or allele in an individual's DNA or RNA. Advancements in this field have provided accurate, easy, and inexpensive large-scale SNP genotyping. Most recently, for example, several new techniques have been described including dynamic allele-specific hybridization (DASH), microplate array diagonal gel electrophoresis (MADGE), pyrosequencing, oligonucleotide-specific ligation, the TaqMan system as well as various DNA "chip" technologies such as the Affymetrix SNP chips. These methods require amplification of the target genetic region, typically by PCR. Still other newly developed methods, based on the generation of small signal molecules by invasive cleavage followed by mass spectrometry or immobilized padlock probes and rolling-circle amplification, might eventually eliminate the need for PCR. Several of the methods known in the art for detecting specific single nucleotide polymorphisms are summarized below. The method of the present invention is understood to include all available methods.

PCR based detection means may include multiplex amplification of a plurality of markers simultaneously. For example, it is well known in the art to select PCR primers to generate PCR products that do not overlap in size and can be analyzed simultaneously.

Alternatively, it is possible to amplify different markers with primers that are differentially labeled and thus can each be differentially detected. Of course, hybridization based

2019203664  
24 May 2019

detection means allow the differential detection of multiple PCR products in a sample. Other techniques are known in the art to allow multiplex analyses of a plurality of markers.

Several methods have been developed to facilitate analysis of single nucleotide polymorphisms in genomic DNA or cellular RNA. In one embodiment, the single base polymorphism can be detected by using a specialized exonuclease-resistant nucleotide, as disclosed, e.g., U.S. Patent No. 4,656,127. According to the method, a primer complementary to the allelic sequence immediately 3' to the polymorphic site is permitted to hybridize to a target molecule obtained from a particular animal or human. If the polymorphic site on the target molecule contains a nucleotide that is complementary to the particular exonuclease-resistant nucleotide derivative present, then that derivative will be incorporated onto the end of the hybridized primer. Such incorporation renders the primer resistant to exonuclease, and thereby permits its detection. Since the identity of the exonuclease-resistant derivative of the sample is known, a finding that the primer has become resistant to exonucleases reveals that the nucleotide present in the polymorphic site of the target molecule was complementary to that of the nucleotide derivative used in the reaction. This method has the advantage that it does not require the determination of large amounts of extraneous sequence data.

In another embodiment of the invention, a solution-based method is used for determining the identity of the nucleotide of a polymorphic site. Cohen et al. (French Patent No. 2,650,840; PCT Application No. WO1991/02087). As in the method of U.S. Patent No. 4,656,127, a primer may be employed that is complementary to allelic sequences immediately 3' to a polymorphic site. The method determines the identity of the nucleotide of that site using labeled dideoxynucleotide derivatives, which, if complementary to the nucleotide of the polymorphic site, will become incorporated onto the terminus of the primer.

25 An alternative method, known as Genetic Bit Analysis or GBA® is described in PCT Application No. WO1992/15712). GBA® uses mixtures of labeled terminators and a primer that is complementary to the sequence 3' to a polymorphic site. The labeled terminator that is incorporated is thus determined by, and complementary to, the nucleotide present in the polymorphic site of the target molecule being evaluated. In contrast to the method of Cohen et al. (French Patent 2,650,840; PCT Application No. W01991/02087) the GBA® method is  
30 preferably a heterogeneous phase assay, in which the primer or the target molecule is immobilized to a solid phase.

2019203664 24 May 2019

Recently, several primer-guided nucleotide incorporation procedures for assaying polymorphic sites in DNA have been described (Komher, J. S. et al., *Nucl. Acids. Res.* 17:7779- 7784 (1989); Sokolov, B. P., *Nucl. Acids Res.* 18:3671 (1990); Syvanen, A.-C, et al., *Genomics* 8:684-692 (1990); Kuppaswamy, M. N. et al., *Proc. Natl. Acad. Sci. (U.S.A.)* 88: 1143- 1147 (1991); Prezant, T. R. et al., *Hum. Mutat.* 1: 159-164 (1992); Ugozzoli, L. et al., *GATA* 9: 107- 112 (1992); Nyren, P. et al., *Anal. Biochem.* 208: 171-175 (1993)). These methods differ from GBA® in that they all rely on the incorporation of labeled deoxynucleotides to discriminate between bases at a polymorphic site. In such a format, since the signal is proportional to the number of deoxynucleotides incorporated, polymorphisms that occur in runs of the same nucleotide can result in signals that are proportional to the length of the run (Syvanen, A.-C, et al., *Amer. J. Hum. Genet.* 52:46-59 (1993)).

An alternative method for identifying tumor specific neo-antigens is direct protein sequencing. Protein sequencing of enzymatic digests using multidimensional MS techniques (MSn) including tandem mass spectrometry (MS/MS)) can also be used to identify neo-antigens of the invention. Such proteomic approaches permit rapid, highly automated analysis (see, e.g., K. Gevaert and J. Vandekerckhove, *Electrophoresis* 21:1145-1154 (2000)). It is further contemplated within the scope of the invention that high-throughput methods for de novo sequencing of unknown proteins may be used to analyze the proteome of a patient's tumor to identify expressed neo-antigens. For example, meta shotgun protein sequencing may be used to identify expressed neo-antigens (see e.g., Guthals et al. (2012) Shotgun Protein Sequencing with Meta-contig Assembly, *Molecular and Cellular Proteomics* 11(10):1084-96).

25 Tumor specific neo-antigens may also be identified using MHC multimers to identify neo-antigen-specific T-cell responses. For example, highthroughput analysis of neo-antigen-specific T-cell responses in patient samples may be performed using MHC tetramer-based  
30 screening techniques (see e.g., Hombrink et al. (2011) High-Throughput Identification of Potential Minor Histocompatibility Antigens by MHC Tetramer-Based Screening: Feasibility and Limitations 6(8):1-11; Hadrup et al. (2009) Parallel detection of antigen-specific T-cell responses by multidimensional encoding of MHC multimers, *Nature Methods*, 6(7):520-26; van Rooij et al. (2013) Tumor exome analysis reveals neoantigen-specific T-cell reactivity in an Ipilimumab-responsive melanoma, *Journal of Clinical Oncology*, 31:1-4; and Heemskerk et al. (2013) The cancer antigenome, *EMBO Journal*, 32(2):194-203). It is contemplated within the

24 May 2019

2019203664

scope of the invention that such tetramer-based screening techniques may be used for the initial identification of tumor specific neo-antigens, or alternatively as a secondary screening protocol to assess what neo-antigens a patient may have already been exposed to, thereby facilitating the selection of candidate neo-antigens for the vaccines of the invention.

### **Design of Tumor Specific Neo-Antigens**

The invention further includes isolated peptides (e.g., neo-antigenic peptides containing the tumor specific mutations identified by the methods of the invention, peptides that comprise known tumor specific mutations, and mutant polypeptides or fragments thereof identified by the method of the invention). These peptides and polypeptides are referred to herein as “neo-antigenic peptides” or “neo-antigenic polypeptides.” The term “peptide” is used interchangeably with “mutant peptide” and “neo-antigenic peptide” and “wildtype peptide” in the present specification to designate a series of residues, typically L-amino acids, connected one to the other, typically by peptide bonds between the alpha-amino and alpha-carboxyl groups of adjacent amino acids. The polypeptides or peptides can be of a variety of lengths and will minimally include the small region predicted to bind to the HLA molecule of the patient (the “epitope”) as well as additional adjacent amino acids extending in both the N- and C-terminal directions. The polypeptides or peptides can be either in their neutral (uncharged) forms or in forms which are salts, and either free of modifications such as glycosylation, side chain oxidation, or phosphorylation or containing these modifications, subject to the condition that the modification not destroy the biological activity of the polypeptides as herein described.

In certain embodiments the size of the at least one neo-antigenic peptide molecule may comprise, but is not limited to, about 8, about 9, about 10, about 11, about 12, about 13, about 14, about 15, about 16, about 17, about 18, about 19, about 20, about 21, about 22, about 23, 25 about 24, about 25, about 26, about 27, about 28, about 29, about 30, about 31, about 32, about 33, about 34, about 35, about 36, about 37, about 38, about 39, about 40, about 41, about 42, about 43, about 44, about 45, about 46, about 47, about 48, about 49, about 50, about 60, about 70, about 80, about 90, about 100, about 110, about 120 or greater amino molecule residues, and any range derivable therein. In specific embodiments the neo-antigenic peptide molecules are 30 equal to or less than 50 amino acids. In a preferred embodiment, the neo-antigenic peptide molecules are equal to about 20 to about 30 amino acids.

2019203664 24 May 2019

A longer peptide may be designed in several ways. For example, when the HLA-binding regions (e.g., the “epitopes”) are predicted or known, a longer peptide may consist of either: individual binding peptides with an extension of 0-10 amino acids toward the N- and C-terminus of each corresponding gene product. A longer peptide may also consist of a concatenation of some or all of the binding peptides with extended sequences for each. In another case, when sequencing reveals a long (>10 residues) neo-epitope sequence present in the tumor (e.g. due to a frameshift, read-through or intron inclusion that leads to a novel peptide sequence), a longer peptide may consist of the entire stretch of novel tumor-specific amino acids. In both cases, use of a longer peptide requires endogenous processing by professional antigen presenting cells such as dendritic cells and may lead to more effective antigen presentation and induction of T cell responses. In some cases, it is desirable or preferable to alter the extended sequence to improve the biochemical properties of the polypeptide (properties such as solubility or stability) or to improve the likelihood for efficient proteasomal processing of the peptide (Zhang et al (2012) Aminopeptidase substrate preference affects HIV epitope presentation and predicts immune escape patterns in HIV-infected individuals. *J. Immunol* 188:5924-34; Hearn et al (2010) Characterizing the specificity and co-operation of aminopeptidases in the cytosol and ER during MHC Class I antigen presentation. *J. Immunol* 184(9):4725-32; Wiemerhaus et al (2012) Peptidases trimming MHC Class I ligands. *Curr Opin Immunol* 25:1-7).

The neo-antigenic peptides and polypeptides may bind an HLA protein. In preferred aspects, the neo-antigenic peptides and polypeptides may bind an HLA protein with greater affinity than the corresponding native / wild-type peptide. The neo-antigenic peptide or polypeptide may have an IC<sub>50</sub> of about less than 1000 nM, about less than 500 nM, about less than 250 nM, about less than 200 nM, about less than 150 nM, about less than 100 nM, or about less than 50 nM.

25 In a preferred embodiment, the neo-antigenic peptides and polypeptides of the invention do not induce an autoimmune response and/or invoke immunological tolerance when administered to a subject.

The invention also provides compositions comprising a plurality of neo-antigenic peptides. In some embodiments, the composition comprises at least 5 or more neo-antigenic  
30 peptides. In some embodiments the composition contains at least about 6, about 8, about 10, about 12, about 14, about 16, about 18, or about 20 distinct peptides. In some embodiments the

2019203664 24 May 2019

composition contains at least 20 distinct peptides. According to the invention, 2 or more of the distinct peptides may be derived from the same polypeptide. For example, if a preferred neo-antigenic mutation encodes a neoORF polypeptide, two or more of the neo-antigenic peptides may be derived from the neoORF polypeptide. In one embodiment, the two or more neo-antigenic peptides derived from the neoORF polypeptide may comprise a tiled array that spans the polypeptide (e.g., the neo-antigenic peptides may comprise a series of overlapping neo-antigenic peptides that spans a portion, or all, of the neoORF polypeptide). Without being bound by theory, each peptide is believed to have its own epitope; accordingly, a tiling array that spans one neoORF polypeptide may give rise to polypeptides that are targeted to different HLA molecules. Neo-antigenic peptides can be derived from any protein coding gene. Exemplary polypeptides from which the neo-antigenic peptides may be derived can be found for example at the COSMIC database (on the worldwide web at ([www](http://www.sanger.ac.uk/cosmic))sanger.ac.uk/cosmic). COSMIC curates comprehensive information on somatic mutations in human cancer. The peptide may contain the tumor specific mutation. In some aspects the tumor specific mutation is in a common driver gene or is a common driver mutation for a particular cancer type. For example, common driver mutation peptides may include, but are not limited to, the following: a SF3B1 polypeptide, a MYD88 polypeptide, a TP53 polypeptide, an ATM polypeptide, an Abl polypeptide, A FBXW7 polypeptide, a DDX3X polypeptide, a MAPK1 polypeptide, or a GNB1 polypeptide.

The neo-antigenic peptides, polypeptides, and analogs can be further modified to contain additional chemical moieties not normally part of the protein. Those derivatized moieties can improve the solubility, the biological half-life, absorption of the protein, or binding affinity. The moieties can also reduce or eliminate any desirable side effects of the proteins and the like. An overview for those moieties can be found in Remington's Pharmaceutical Sciences, 20<sup>th</sup> ed., Mack Publishing Co., Easton, PA (2000).

25 For example, neo-antigenic peptides and polypeptides having the desired activity may be modified as necessary to provide certain desired attributes, e.g. improved pharmacological characteristics, while increasing or at least retaining substantially all of the biological activity of the unmodified peptide to bind the desired MHC molecule and activate the appropriate T cell. For instance, the neo-antigenic peptide and polypeptides may be subject to various changes, such as substitutions, either conservative or non-conservative, where such changes might provide for  
30 certain advantages in their use, such as improved MHC binding. Such conservative substitutions

2019203664  
24 May 2019

2019203664

may encompass replacing an amino acid residue with another amino acid residue that is biologically and/or chemically similar, e.g., one hydrophobic residue for another, or one polar residue for another. The effect of single amino acid substitutions may also be probed using D-amino acids. Such modifications may be made using well known peptide synthesis procedures, as described in e.g., Merrifield, *Science* 232:341-347 (1986), Barany & Merrifield, *The Peptides*, Gross & Meienhofer, eds. (N.Y., Academic Press), pp. 1-284 (1979); and Stewart & Young, *Solid Phase Peptide Synthesis*, (Rockford, Ill., Pierce), 2d Ed. (1984).

The neo-antigenic peptide and polypeptides may also be modified by extending or decreasing the compound's amino acid sequence, e.g., by the addition or deletion of amino acids. The neo-antigenic peptides, polypeptides, or analogs can also be modified by altering the order or composition of certain residues. It will be appreciated by the skilled artisan that certain amino acid residues essential for biological activity, e.g., those at critical contact sites or conserved residues, may generally not be altered without an adverse effect on biological activity. The non-critical amino acids need not be limited to those naturally occurring in proteins, such as L- $\alpha$ -amino acids, or their D-isomers, but may include non-natural amino acids as well, such as  $\beta$ - $\gamma$ - $\delta$ -amino acids, as well as many derivatives of L- $\alpha$ -amino acids.

Typically, a neo-antigen polypeptide or peptide may be optimized by using a series of peptides with single amino acid substitutions to determine the effect of electrostatic charge, hydrophobicity, etc. on MHC binding. For instance, a series of positively charged (e.g., Lys or Arg) or negatively charged (e.g., Glu) amino acid substitutions may be made along the length of the peptide revealing different patterns of sensitivity towards various MHC molecules and T cell receptors. In addition, multiple substitutions using small, relatively neutral moieties such as Ala, Gly, Pro, or similar residues may be employed. The substitutions may be homo-oligomers or hetero-oligomers. The number and types of residues which are substituted or added depend on the spacing necessary between essential contact points and certain functional attributes which are sought (e.g., hydrophobicity versus hydrophilicity). Increased binding affinity for an MHC molecule or T cell receptor may also be achieved by such substitutions, compared to the affinity of the parent peptide. In any event, such substitutions should employ amino acid residues or other molecular fragments chosen to avoid, for example, steric and charge interference which might disrupt binding.



2019203664 24 May 2019

Amino acid substitutions are typically of single residues. Substitutions, deletions, insertions or any combination thereof may be combined to arrive at a final peptide. Substitutional variants are those in which at least one residue of a peptide has been removed and a different residue inserted in its place.

The neo-antigenic peptides and polypeptides may be modified to provide desired attributes. For instance, the ability of the peptides to induce CTL activity can be enhanced by linkage to a sequence which contains at least one epitope that is capable of inducing a T helper cell response. Particularly preferred immunogenic peptides/T helper conjugates are linked by a spacer molecule. The spacer is typically comprised of relatively small, neutral molecules, such as amino acids or amino acid mimetics, which are substantially uncharged under physiological conditions. The spacers are typically selected from, e.g., Ala, Gly, or other neutral spacers of nonpolar amino acids or neutral polar amino acids. It will be understood that the optionally present spacer need not be comprised of the same residues and thus may be a hetero- or homo-oligomer. When present, the spacer will usually be at least one or two residues, more usually three to six residues. Alternatively, the peptide may be linked to the T helper peptide without a spacer.

The neo-antigenic peptide may be linked to the T helper peptide either directly or via a spacer either at the amino or carboxy terminus of the peptide. The amino terminus of either the neo-antigenic peptide or the T helper peptide may be acylated. Exemplary T helper peptides include tetanus toxoid 830-843, influenza 307-319, malaria circumsporozoite 382-398 and 378-389.

### **Production of Tumor Specific Neo-antigens**

25 The present invention is based, at least in part, on the ability to present the immune system of the patient with a pool of tumor specific neo-antigens. One of skill in the art will appreciate that there are a variety of ways in which to produce such tumor specific neo-antigens. In general, such tumor specific neo-antigens may be produced either in vitro or in vivo. Tumor specific neo-antigens may be produced in vitro as peptides or polypeptides, which may then be formulated into a personalized neoplasia vaccine and administered to a subject. As described in  
30 further detail below, such in vitro production may occur by a variety of methods known to one of skill in the art such as, for example, peptide synthesis or expression of a peptide/polypeptide

2019203664  
24 May 2019

from a DNA or RNA molecule in any of a variety of bacterial, eukaryotic, or viral recombinant expression systems, followed by purification of the expressed peptide/polypeptide.

Alternatively, tumor specific neo-antigens may be produced in vivo by introducing molecules (e.g., DNA, RNA, viral expression systems, and the like) that encode tumor specific neo-antigens into a subject, whereupon the encoded tumor specific neo-antigens are expressed.

### **In Vitro Peptide/Polypeptide Synthesis**

Proteins or peptides may be made by any technique known to those of skill in the art, including the expression of proteins, polypeptides or peptides through standard molecular biological techniques, the isolation of proteins or peptides from natural sources, or the chemical synthesis of proteins or peptides. The nucleotide and protein, polypeptide and peptide sequences corresponding to various genes have been previously disclosed, and may be found at computerized databases known to those of ordinary skill in the art. One such database is the National Center for Biotechnology Information's Genbank and GenPept databases located at the National Institutes of Health website. The coding regions for known genes may be amplified and/or expressed using the techniques disclosed herein or as would be known to those of ordinary skill in the art. Alternatively, various commercial preparations of proteins, polypeptides and peptides are known to those of skill in the art.

Peptides can be readily synthesized chemically utilizing reagents that are free of contaminating bacterial or animal substances (Merrifield RB: Solid phase peptide synthesis. I. The synthesis of a tetrapeptide. J. Am. Chem. Soc. 85:2149-54, 1963).

A further aspect of the invention provides a nucleic acid (e.g., a polynucleotide) encoding a neo-antigenic peptide of the invention, which may be used to produce the neo-antigenic peptide in vitro. The polynucleotide may be, e.g., DNA, cDNA, PNA, CNA, RNA, either single- and/or double-stranded, or native or stabilized forms of polynucleotides, such as e.g. polynucleotides with a phosphorothiate backbone, or combinations thereof and it may or may not contain introns so long as it codes for the peptide. A still further aspect of the invention provides an expression vector capable of expressing a polypeptide according to the invention. Expression vectors for different cell types are well known in the art and can be selected without undue experimentation.

Generally, the DNA is inserted into an expression vector, such as a plasmid, in proper orientation and correct reading frame for expression. If necessary, the DNA may be linked to the

2019203664  
24 May 2019

2019203664

appropriate transcriptional and translational regulatory control nucleotide sequences recognized by the desired host (e.g., bacteria), although such controls are generally available in the expression vector. The vector is then introduced into the host bacteria for cloning using standard techniques (see, e.g., Sambrook et al. (1989) *Molecular Cloning, A Laboratory Manual*, Cold Spring Harbor Laboratory, Cold Spring Harbor, N.Y.).

The invention further embraces variants and equivalents which are substantially homologous to the identified tumor specific neo-antigens described herein. These can contain, for example, conservative substitution mutations, i.e., the substitution of one or more amino acids by similar amino acids. For example, conservative substitution refers to the substitution of an amino acid with another within the same general class such as, for example, one acidic amino acid with another acidic amino acid, one basic amino acid with another basic amino acid, or one neutral amino acid by another neutral amino acid. What is intended by a conservative amino acid substitution is well known in the art.

The invention also includes expression vectors comprising the isolated polynucleotides, as well as host cells containing the expression vectors. It is also contemplated within the scope of the invention that the neo-antigenic peptides may be provided in the form of RNA or cDNA molecules encoding the desired neo-antigenic peptides. The invention also provides that the one or more neo-antigenic peptides of the invention may be encoded by a single expression vector. The invention also provides that the one or more neo-antigenic peptides of the invention may be encoded and expressed in vivo using a viral based system (e.g., an adenovirus system).

The term "polynucleotide encoding a polypeptide" encompasses a polynucleotide which includes only coding sequences for the polypeptide as well as a polynucleotide which includes additional coding and/or non-coding sequences. The polynucleotides of the invention can be in the form of RNA or in the form of DNA. DNA includes cDNA, genomic DNA, and synthetic  
25 DNA; and can be double-stranded or single-stranded, and if single stranded can be the coding strand or non-coding (anti-sense) strand.

In embodiments, the polynucleotides may comprise the coding sequence for the tumor specific neo-antigenic peptide fused in the same reading frame to a polynucleotide which aids,  
30 for example, in expression and/or secretion of a polypeptide from a host cell (e.g., a leader sequence which functions as a secretory sequence for controlling transport of a polypeptide from

2019203664  
24 May 2019

the cell). The polypeptide having a leader sequence is a preprotein and can have the leader sequence cleaved by the host cell to form the mature form of the polypeptide.

In embodiments, the polynucleotides can comprise the coding sequence for the tumor specific neo-antigenic peptide fused in the same reading frame to a marker sequence that allows, for example, for purification of the encoded polypeptide, which may then be incorporated into the personalized neoplasia vaccine. For example, the marker sequence can be a hexa-histidine tag supplied by a pQE-9 vector to provide for purification of the mature polypeptide fused to the marker in the case of a bacterial host, or the marker sequence can be a hemagglutinin (HA) tag derived from the influenza hemagglutinin protein when a mammalian host (e.g., COS-7 cells) is used. Additional tags include, but are not limited to, Calmodulin tags, FLAG tags, Myc tags, S tags, SBP tags, Softag 1, Softag 3, V5 tag, Xpress tag, Isopeptag, SpyTag, Biotin Carboxyl Carrier Protein (BCCP) tags, GST tags, fluorescent protein tags (e.g., green fluorescent protein tags), maltose binding protein tags, Nus tags, Strep-tag, thioredoxin tag, TC tag, Ty tag, and the like.

In embodiments, the polynucleotides may comprise the coding sequence for one or more of the tumor specific neo-antigenic peptides fused in the same reading frame to create a single concatamerized neo-antigenic peptide construct capable of producing multiple neo-antigenic peptides.

In embodiments, the present invention provides isolated nucleic acid molecules having a nucleotide sequence at least 60% identical, at least 65% identical, at least 70% identical, at least 75% identical, at least 80% identical, at least 85% identical, at least 90% identical, at least 95% identical, or at least 96%, 97%, 98% or 99% identical to a polynucleotide encoding a tumor specific neo-antigenic peptide of the present invention.

25 By a polynucleotide having a nucleotide sequence at least, for example, 95% "identical" to a reference nucleotide sequence is intended that the nucleotide sequence of the polynucleotide is identical to the reference sequence except that the polynucleotide sequence can include up to five point mutations per each 100 nucleotides of the reference nucleotide sequence. In other words, to obtain a polynucleotide having a nucleotide sequence at least 95% identical to a reference nucleotide sequence, up to 5% of the nucleotides in the reference sequence can be  
30 deleted or substituted with another nucleotide, or a number of nucleotides up to 5% of the total

24 May 2019

2019203664

nucleotides in the reference sequence can be inserted into the reference sequence. These mutations of the reference sequence can occur at the amino- or carboxy-terminal positions of the reference nucleotide sequence or anywhere between those terminal positions, interspersed either individually among nucleotides in the reference sequence or in one or more contiguous groups within the reference sequence.

As a practical matter, whether any particular nucleic acid molecule is at least 80% identical, at least 85% identical, at least 90% identical, and in some embodiments, at least 95%, 96%, 97%, 98%, or 99% identical to a reference sequence can be determined conventionally using known computer programs such as the Bestfit program (Wisconsin Sequence Analysis Package, Version 8 for Unix, Genetics Computer Group, University Research Park, 575 Science Drive, Madison, WI 53711). Bestfit uses the local homology algorithm of Smith and Waterman, *Advances in Applied Mathematics* 2:482-489 (1981), to find the best segment of homology between two sequences. When using Bestfit or any other sequence alignment program to determine whether a particular sequence is, for instance, 95% identical to a reference sequence according to the present invention, the parameters are set such that the percentage of identity is calculated over the full length of the reference nucleotide sequence and that gaps in homology of up to 5% of the total number of nucleotides in the reference sequence are allowed.

The isolated tumor specific neo-antigenic peptides described herein can be produced in vitro (e.g., in the laboratory) by any suitable method known in the art. Such methods range from direct protein synthetic methods to constructing a DNA sequence encoding isolated polypeptide sequences and expressing those sequences in a suitable transformed host. In some embodiments, a DNA sequence is constructed using recombinant technology by isolating or synthesizing a DNA sequence encoding a wild-type protein of interest. Optionally, the sequence can be mutagenized by site-specific mutagenesis to provide functional analogs thereof. *See, e.g. Zoeller et al., Proc. Nat'l. Acad. Sci. USA* 81:5662-5066 (1984) and U.S. Pat. No. 4,588,585.

In embodiments, a DNA sequence encoding a polypeptide of interest would be constructed by chemical synthesis using an oligonucleotide synthesizer. Such oligonucleotides can be designed based on the amino acid sequence of the desired polypeptide and selecting those codons that are favored in the host cell in which the recombinant polypeptide of interest will be produced. Standard methods can be applied to synthesize an isolated polynucleotide sequence

2019203664 24 May 2019

2019203664

encoding an isolated polypeptide of interest. For example, a complete amino acid sequence can be used to construct a back-translated gene. Further, a DNA oligomer containing a nucleotide sequence coding for the particular isolated polypeptide can be synthesized. For example, several small oligonucleotides coding for portions of the desired polypeptide can be synthesized and then ligated. The individual oligonucleotides typically contain 5' or 3' overhangs for complementary assembly.

Once assembled (e.g., by synthesis, site-directed mutagenesis, or another method), the polynucleotide sequences encoding a particular isolated polypeptide of interest will be inserted into an expression vector and optionally operatively linked to an expression control sequence appropriate for expression of the protein in a desired host. Proper assembly can be confirmed by nucleotide sequencing, restriction mapping, and expression of a biologically active polypeptide in a suitable host. As well known in the art, in order to obtain high expression levels of a transfected gene in a host, the gene can be operatively linked to transcriptional and translational expression control sequences that are functional in the chosen expression host.

Recombinant expression vectors may be used to amplify and express DNA encoding the tumor specific neo-antigenic peptides. Recombinant expression vectors are replicable DNA constructs which have synthetic or cDNA-derived DNA fragments encoding a tumor specific neo-antigenic peptide or a bioequivalent analog operatively linked to suitable transcriptional or translational regulatory elements derived from mammalian, microbial, viral or insect genes. A transcriptional unit generally comprises an assembly of (1) a genetic element or elements having a regulatory role in gene expression, for example, transcriptional promoters or enhancers, (2) a structural or coding sequence which is transcribed into mRNA and translated into protein, and (3) appropriate transcription and translation initiation and termination sequences, as described in detail below. Such regulatory elements can include an operator sequence to control

25 transcription. The ability to replicate in a host, usually conferred by an origin of replication, and a selection gene to facilitate recognition of transformants can additionally be incorporated. DNA regions are operatively linked when they are functionally related to each other. For example, DNA for a signal peptide (secretory leader) is operatively linked to DNA for a polypeptide if it is expressed as a precursor which participates in the secretion of the polypeptide; a promoter is  
30 operatively linked to a coding sequence if it controls the transcription of the sequence; or a ribosome binding site is operatively linked to a coding sequence if it is positioned so as to permit

2019203664 24 May 2019

2019203664

translation. Generally, operatively linked means contiguous, and in the case of secretory leaders, means contiguous and in reading frame. Structural elements intended for use in yeast expression systems include a leader sequence enabling extracellular secretion of translated protein by a host cell. Alternatively, where recombinant protein is expressed without a leader or transport sequence, it can include an N-terminal methionine residue. This residue can optionally be subsequently cleaved from the expressed recombinant protein to provide a final product.

The choice of expression control sequence and expression vector will depend upon the choice of host. A wide variety of expression host/vector combinations can be employed. Useful expression vectors for eukaryotic hosts, include, for example, vectors comprising expression control sequences from SV40, bovine papilloma virus, adenovirus and cytomegalovirus. Useful expression vectors for bacterial hosts include known bacterial plasmids, such as plasmids from *Escherichia coli*, including pCR 1, pBR322, pMB9 and their derivatives, wider host range plasmids, such as M13 and filamentous single-stranded DNA phages.

Suitable host cells for expression of a polypeptide include prokaryotes, yeast, insect or higher eukaryotic cells under the control of appropriate promoters. Prokaryotes include gram negative or gram positive organisms, for example *E. coli* or *bacilli*. Higher eukaryotic cells include established cell lines of mammalian origin. Cell-free translation systems could also be employed. Appropriate cloning and expression vectors for use with bacterial, fungal, yeast, and mammalian cellular hosts are well known in the art (see Pouwels *et al.*, *Cloning Vectors: A Laboratory Manual*, Elsevier, N.Y., 1985).

Various mammalian or insect cell culture systems are also advantageously employed to express recombinant protein. Expression of recombinant proteins in mammalian cells can be performed because such proteins are generally correctly folded, appropriately modified and completely functional. Examples of suitable mammalian host cell lines include the COS-7 lines of monkey kidney cells, described by Gluzman (*Cell* 23:175, 1981), and other cell lines capable of expressing an appropriate vector including, for example, L cells, C127, 3T3, Chinese hamster ovary (CHO), HeLa and BHK cell lines. Mammalian expression vectors can comprise nontranscribed elements such as an origin of replication, a suitable promoter and enhancer linked to the gene to be expressed, and other 5' or 3' flanking nontranscribed sequences, and 5' or 3' nontranslated sequences, such as necessary ribosome binding sites, a polyadenylation site, splice

2019203664 24 May 2019

donor and acceptor sites, and transcriptional termination sequences. Baculovirus systems for production of heterologous proteins in insect cells are reviewed by Luckow and Summers, *Bio/Technology* 6:47 (1988).

The proteins produced by a transformed host can be purified according to any suitable method. Such standard methods include chromatography (e.g., ion exchange, affinity and sizing column chromatography, and the like), centrifugation, differential solubility, or by any other standard technique for protein purification. Affinity tags such as hexahistidine, maltose binding domain, influenza coat sequence, glutathione-S-transferase, and the like can be attached to the protein to allow easy purification by passage over an appropriate affinity column. Isolated proteins can also be physically characterized using such techniques as proteolysis, nuclear magnetic resonance and x-ray crystallography.

For example, supernatants from systems which secrete recombinant protein into culture media can be first concentrated using a commercially available protein concentration filter, for example, an Amicon or Millipore Pellicon ultrafiltration unit. Following the concentration step, the concentrate can be applied to a suitable purification matrix. Alternatively, an anion exchange resin can be employed, for example, a matrix or substrate having pendant diethylaminoethyl (DEAE) groups. The matrices can be acrylamide, agarose, dextran, cellulose or other types commonly employed in protein purification. Alternatively, a cation exchange step can be employed. Suitable cation exchangers include various insoluble matrices comprising sulfopropyl or carboxymethyl groups. Finally, one or more reversed-phase high performance liquid chromatography (RP-HPLC) steps employing hydrophobic RP-HPLC media, e.g., silica gel having pendant methyl or other aliphatic groups, can be employed to further purify a cancer stem cell protein-Fc composition. Some or all of the foregoing purification steps, in various combinations, can also be employed to provide a homogeneous recombinant protein.

25 Recombinant protein produced in bacterial culture can be isolated, for example, by initial extraction from cell pellets, followed by one or more concentration, salting-out, aqueous ion exchange or size exclusion chromatography steps. High performance liquid chromatography (HPLC) can be employed for final purification steps. Microbial cells employed in expression of a recombinant protein can be disrupted by any convenient method, including freeze-thaw  
30 cycling, sonication, mechanical disruption, or use of cell lysing agents.



### In Vivo Peptide/Polypeptide Synthesis

The present invention also contemplates the use of nucleic acid molecules as vehicles for delivering neo-antigenic peptides/polypeptides to the subject in vivo in the form of, e.g., DNA/RNA vaccines (see, e.g., WO2012/159643, and WO2012/159754, hereby incorporated by reference in their entirety).

In one embodiment, the personalized neoplasia vaccine may include separate DNA plasmids encoding, for example, one or more neo-antigenic peptides/polypeptides as identified in according to the invention. As discussed above, the exact choice of expression vectors will depend upon the peptide/polypeptides to be expressed, and is well within the skill of the ordinary artisan. The expected persistence of the DNA constructs (e.g., in an episomal, non-replicating, non-integrated form in the muscle cells) is expected to provide an increased duration of protection.

In another embodiment, the personalized neoplasia vaccine may include separate RNA or cDNA molecules encoding neo-antigenic peptides/polypeptides of the invention.

In another embodiment the personalized neoplasia vaccine may include a viral based vector for use in a human patient such as, for example, and adenovirus system (see, e.g., Baden et al. First-in-human evaluation of the safety and immunogenicity of a recombinant adenovirus serotype 26 HIV-1 Env vaccine (IPCAVD 001). J Infect Dis. 2013 Jan 15;207(2):240-7, hereby incorporated by reference in its entirety).

### Pharmaceutical Compositions/Methods of Delivery

The present invention is also directed to pharmaceutical compositions comprising an effective amount of one or more compounds according to the present invention (including a pharmaceutically acceptable salt, thereof), optionally in combination with a pharmaceutically acceptable carrier, excipient or additive.

A “pharmaceutically acceptable derivative or prodrug” means any pharmaceutically acceptable salt, ester, salt of an ester, or other derivative of a compound of this invention which,

2019203664 24 May 2019

upon administration to a recipient, is capable of providing (directly or indirectly) a compound of this invention. Particularly favored derivatives and prodrugs are those that increase the bioavailability of the compounds of this invention when such compounds are administered to a mammal (e.g., by allowing an orally or ocularly administered compound to be more readily absorbed into the blood) or which enhance delivery of the parent compound to a biological compartment (e.g., the retina) relative to the parent species.

While the tumor specific neo-antigenic peptides of the invention can be administered as the sole active pharmaceutical agent, they can also be used in combination with one or more other agents and/or adjuvants. When administered as a combination, the therapeutic agents can be formulated as separate compositions that are given at the same time or different times, or the therapeutic agents can be given as a single composition.

The tumor specific neo-antigenic peptides of the present invention may be administered by injection, orally, parenterally, by inhalation spray, rectally, vaginally, or topically in dosage unit formulations containing conventional pharmaceutically acceptable carriers, adjuvants, and vehicles. The term parenteral as used herein includes, into a lymph node or nodes, subcutaneous, intravenous, intramuscular, intrasternal, infusion techniques, intraperitoneally, eye or ocular, intravitreal, intrabuccal, transdermal, intranasal, into the brain, including intracranial and intradural, into the joints, including ankles, knees, hips, shoulders, elbows, wrists, directly into tumors, and the like, and in suppository form.

20 The pharmaceutically active compounds of this invention can be processed in accordance with conventional methods of pharmacy to produce medicinal agents for administration to patients, including humans and other mammals.

Modifications of the active compound can affect the solubility, bioavailability and rate of metabolism of the active species, thus providing control over the delivery of the active species.  
25 This can easily be assessed by preparing the derivative and testing its activity according to known methods well within the routine practitioner's skill in the art.

Pharmaceutical compositions based upon these chemical compounds comprise the above-described tumor specific neo-antigenic peptides in a therapeutically effective amount for treating

2019203664 24 May 2019

diseases and conditions (e.g., a neoplasia/tumor), which have been described herein, optionally in combination with a pharmaceutically acceptable additive, carrier and/or excipient. One of ordinary skill in the art will recognize that a therapeutically effective amount of one of more compounds according to the present invention will vary with the infection or condition to be treated, its severity, the treatment regimen to be employed, the pharmacokinetics of the agent used, as well as the patient (animal or human) treated.

To prepare the pharmaceutical compositions according to the present invention, a therapeutically effective amount of one or more of the compounds according to the present invention is preferably intimately admixed with a pharmaceutically acceptable carrier according to conventional pharmaceutical compounding techniques to produce a dose. A carrier may take a wide variety of forms depending on the form of preparation desired for administration, e.g., ocular, oral, topical or parenteral, including gels, creams ointments, lotions and time released implantable preparations, among numerous others. In preparing pharmaceutical compositions in oral dosage form, any of the usual pharmaceutical media may be used. Thus, for liquid oral preparations such as suspensions, elixirs and solutions, suitable carriers and additives including water, glycols, oils, alcohols, flavoring agents, preservatives, coloring agents and the like may be used. For solid oral preparations such as powders, tablets, capsules, and for solid preparations such as suppositories, suitable carriers and additives including starches, sugar carriers, such as dextrose, mannitol, lactose and related carriers, diluents, granulating agents, lubricants, binders, disintegrating agents and the like may be used. If desired, the tablets or capsules may be enteric-coated or sustained release by standard techniques.

The active compound is included in the pharmaceutically acceptable carrier or diluent in an amount sufficient to deliver to a patient a therapeutically effective amount for the desired indication, without causing serious toxic effects in the patient treated.

25 Oral compositions will generally include an inert diluent or an edible carrier. They may be enclosed in gelatin capsules or compressed into tablets. For the purpose of oral therapeutic administration, the active compound or its prodrug derivative can be incorporated with excipients and used in the form of tablets, troches, or capsules. Pharmaceutically compatible binding agents, and/or adjuvant materials can be included as part of the composition.

The tablets, pills, capsules, troches and the like can contain any of the following ingredients, or compounds of a similar nature: a binder such as microcrystalline cellulose, gum tragacanth or gelatin; an excipient such as starch or lactose, a dispersing agent such as alginic acid or corn starch; a lubricant such as magnesium stearate; a glidant such as colloidal silicon dioxide; a sweetening agent such as sucrose or saccharin; or a flavoring agent such as peppermint, methyl salicylate, or orange flavoring. When the dosage unit form is a capsule, it can contain, in addition to material-of the above type, a liquid carrier such as a fatty oil. In addition, dosage unit forms can contain various other materials which modify the physical form of the dosage unit, for example, coatings of sugar, shellac, or enteric agents.

Formulations of the present invention suitable for oral administration may be presented as discrete units such as capsules, cachets or tablets each containing a predetermined amount of the active ingredient; as a powder or granules; as a solution or a suspension in an aqueous liquid or a non-aqueous liquid; or as an oil-in-water liquid emulsion or a water-in-oil emulsion and as a bolus, etc.

A tablet may be made by compression or molding, optionally with one or more accessory ingredients. Compressed tablets may be prepared by compressing in a suitable machine the active ingredient in a free-flowing form such as a powder or granules, optionally mixed with a binder, lubricant, inert diluent, preservative, surface-active or dispersing agent. Molded tablets may be made by molding in a suitable machine a mixture of the powdered compound moistened with an inert liquid diluent. The tablets optionally may be coated or scored and may be formulated so as to provide slow or controlled release of the active ingredient therein.

Methods of formulating such slow or controlled release compositions of pharmaceutically active ingredients, are known in the art and described in several issued US Patents, some of which include, but are not limited to, US Patent Nos. 3,870,790; 4,226,859; 4,369,172; 4,842,866 and 5,705,190, the disclosures of which are incorporated herein by reference in their entireties. Coatings can be used for delivery of compounds to the intestine (see, e.g., U.S. Patent Nos. 6,638,534, 5,541,171, 5,217,720, and 6,569,457, and references cited therein).

The active compound or pharmaceutically acceptable salt thereof may also be administered as a component of an elixir, suspension, syrup, wafer, chewing gum or the like. A

2019203664 24 May 2019

syrup may contain, in addition to the active compounds, sucrose or fructose as a sweetening agent and certain preservatives, dyes and colorings and flavors.

Solutions or suspensions used for ocular, parenteral, intradermal, subcutaneous, or topical application can include the following components: a sterile diluent such as water for injection, saline solution, fixed oils, polyethylene glycols, glycerine, propylene glycol or other synthetic solvents; antibacterial agents such as benzyl alcohol or methyl parabens; antioxidants such as ascorbic acid or sodium bisulfite; chelating agents such as ethylenediaminetetraacetic acid; buffers such as acetates, citrates or phosphates and agents for the adjustment of tonicity such as sodium chloride or dextrose.

In one embodiment, the active compounds are prepared with carriers that will protect the compound against rapid elimination from the body, such as a controlled release formulation, including implants and microencapsulated delivery systems. Biodegradable, biocompatible polymers can be used, such as ethylene vinyl acetate, polyanhydrides, polyglycolic acid, collagen, polyorthoesters, polylactic acid, and polylactic-co-glycolic acid (PLGA). Methods for preparation of such formulations will be apparent to those skilled in the art.

A skilled artisan will recognize that in addition to tablets, other dosage forms can be formulated to provide slow or controlled release of the active ingredient. Such dosage forms include, but are not limited to, capsules, granulations and gel-caps.

20 Liposomal suspensions may also be pharmaceutically acceptable carriers. These may be prepared according to methods known to those skilled in the art. For example, liposomal formulations may be prepared by dissolving appropriate lipid(s) in an inorganic solvent that is then evaporated, leaving behind a thin film of dried lipid on the surface of the container. An aqueous solution of the active compound are then introduced into the container. The container is then swirled by hand to free lipid material from the sides of the container and to disperse lipid  
25 aggregates, thereby forming the liposomal suspension. Other methods of preparation well known by those of ordinary skill may also be used in this aspect of the present invention.

The formulations may conveniently be presented in unit dosage form and may be prepared by conventional pharmaceutical techniques. Such techniques include the step of

24 May 2019

2019203664

bringing into association the active ingredient and the pharmaceutical carrier(s) or excipient(s). In general, the formulations are prepared by uniformly and intimately bringing into association the active ingredient with liquid carriers or finely divided solid carriers or both, and then, if necessary, shaping the product.

Formulations and compositions suitable for topical administration in the mouth include lozenges comprising the ingredients in a flavored basis, usually sucrose and acacia or tragacanth; pastilles comprising the active ingredient in an inert basis such as gelatin and glycerin, or sucrose and acacia; and mouthwashes comprising the ingredient to be administered in a suitable liquid carrier.

Formulations suitable for topical administration to the skin may be presented as ointments, creams, gels and pastes comprising the ingredient to be administered in a pharmaceutical acceptable carrier. A preferred topical delivery system is a transdermal patch containing the ingredient to be administered.

Formulations for rectal administration may be presented as a suppository with a suitable base comprising, for example, cocoa butter or a salicylate.

Formulations suitable for nasal administration, wherein the carrier is a solid, include a coarse powder having a particle size, for example, in the range of 20 to 500 microns which is administered in the manner in which snuff is administered, i.e., by rapid inhalation through the nasal passage from a container of the powder held close up to the nose. Suitable formulations, wherein the carrier is a liquid, for administration, as for example, a nasal spray or as nasal drops, include aqueous or oily solutions of the active ingredient.

Formulations suitable for vaginal administration may be presented as pessaries, tampons, creams, gels, pastes, foams or spray formulations containing in addition to the active ingredient such carriers as are known in the art to be appropriate.

The parenteral preparation can be enclosed in ampoules, disposable syringes or multiple dose vials made of glass or plastic. If administered intravenously, preferred carriers include, for example, physiological saline or phosphate buffered saline (PBS).

2019203664  
24 May 2019

2019203664

For parenteral formulations, the carrier will usually comprise sterile water or aqueous sodium chloride solution, though other ingredients including those which aid dispersion may be included. Of course, where sterile water is to be used and maintained as sterile, the compositions and carriers will also be sterilized. Injectable suspensions may also be prepared, in which case appropriate liquid carriers, suspending agents and the like may be employed.

Formulations suitable for parenteral administration include aqueous and non-aqueous sterile injection solutions which may contain antioxidants, buffers, bacteriostats and solutes which render the formulation isotonic with the blood of the intended recipient; and aqueous and non-aqueous sterile suspensions which may include suspending agents and thickening agents. The formulations may be presented in unit-dose or multi-dose containers, for example, sealed ampules and vials, and may be stored in a freeze-dried (lyophilized) condition requiring only the addition of the sterile liquid carrier, for example, water for injections, immediately prior to use. Extemporaneous injection solutions and suspensions may be prepared from sterile powders, granules and tablets of the kind previously described.

Administration of the active compound may range from continuous (intravenous drip) to several oral administrations per day (for example, Q.I.D.) and may include oral, topical, eye or ocular, parenteral, intramuscular, intravenous, sub-cutaneous, transdermal (which may include a penetration enhancement agent), buccal and suppository administration, among other routes of administration, including through an eye or ocular route.

20 Application of the subject therapeutics may be local, so as to be administered at the site of interest. Various techniques can be used for providing the subject compositions at the site of interest, such as injection, use of catheters, trocars, projectiles, pluronic gel, stents, sustained drug release polymers or other device which provides for internal access. Where an organ or tissue is accessible because of removal from the patient, such organ or tissue may be bathed in a  
25 medium containing the subject compositions, the subject compositions may be painted onto the organ, or may be applied in any convenient way.

The tumor specific neo-antigenic peptides may be administered through a device suitable for the controlled and sustained release of a composition effective in obtaining a desired local or systemic physiological or pharmacological effect. The method includes positioning the sustained

2019203664 24 May 2019

released drug delivery system at an area wherein release of the agent is desired and allowing the agent to pass through the device to the desired area of treatment.

The tumor specific neo-antigenic peptides may be utilized in combination with at least one known other therapeutic agent, or a pharmaceutically acceptable salt of said agent. Examples of known therapeutic agents which can be used for combination therapy include, but are not limited to, corticosteroids (e.g., cortisone, prednisone, dexamethasone), non-steroidal anti-inflammatory drugs (NSAIDS) (e.g., ibuprofen, celecoxib, aspirin, indomethacin, naproxen), alkylating agents such as busulfan, cis-platin, mitomycin C, and carboplatin; antimitotic agents such as colchicine, vinblastine, paclitaxel, and docetaxel; topo I inhibitors such as camptothecin and topotecan; topo II inhibitors such as doxorubicin and etoposide; and/or RNA/DNA antimetabolites such as 5-azacytidine, 5-fluorouracil and methotrexate; DNA antimetabolites such as 5-fluoro-2'-deoxy-uridine, ara-C, hydroxyurea and thioguanine; antibodies such as Herceptin® and Rituxan®.

It should be understood that in addition to the ingredients particularly mentioned above, the formulations of the present invention may include other agents conventional in the art having regard to the type of formulation in question, for example, those suitable for oral administration may include flavoring agents.

20 In certain pharmaceutical dosage forms, the pro-drug form of the compounds may be preferred. One of ordinary skill in the art will recognize how to readily modify the present compounds to pro-drug forms to facilitate delivery of active compounds to a targeted site within the host organism or patient. The routine practitioner also will take advantage of favorable pharmacokinetic parameters of the pro-drug forms, where applicable, in delivering the present compounds to a targeted site within the host organism or patient to maximize the intended effect of the compound.

25 Preferred prodrugs include derivatives where a group which enhances aqueous solubility or active transport through the gut membrane is appended to the structure of formulae described herein. See, e.g., Alexander, J. et al. *Journal of Medicinal Chemistry* **1988**, *31*, 318-322; Bundgaard, H. *Design of Prodrugs*; Elsevier: Amsterdam, 1985; pp 1-92; Bundgaard, H.; Nielsen, N. M. *Journal of Medicinal Chemistry* 1987, *30*, 451-454; Bundgaard, H. *A Textbook*



2019203664 24 May 2019

of Drug Design and Development; Harwood Academic Publ.: Switzerland, 1991; pp 113-191; Digenis, G. A. et al. Handbook of Experimental Pharmacology 1975, 28, 86-112; Friis, G. J.; Bundgaard, H. A Textbook of Drug Design and Development; 2 ed.; Overseas Publ.: Amsterdam, 1996; pp 351-385; Pitman, I. H. Medicinal Research Reviews 1981, 1, 189-214. The prodrug forms may be active themselves, or may be those such that when metabolized after administration provide the active therapeutic agent in vivo.

Pharmaceutically acceptable salt forms may be the preferred chemical form of compounds according to the present invention for inclusion in pharmaceutical compositions according to the present invention.

The present compounds or their derivatives, including prodrug forms of these agents, can be provided in the form of pharmaceutically acceptable salts. As used herein, the term pharmaceutically acceptable salts or complexes refers to appropriate salts or complexes of the active compounds according to the present invention which retain the desired biological activity of the parent compound and exhibit limited toxicological effects to normal cells. Nonlimiting examples of such salts are (a) acid addition salts formed with inorganic acids (for example, hydrochloric acid, hydrobromic acid, sulfuric acid, phosphoric acid, nitric acid, and the like), and salts formed with organic acids such as acetic acid, oxalic acid, tartaric acid, succinic acid, malic acid, ascorbic acid, benzoic acid, tannic acid, pamoic acid, alginic acid, and polyglutamic acid, among others; (b) base addition salts formed with metal cations such as zinc, calcium, sodium, potassium, and the like, among numerous others.

The compounds herein are commercially available or can be synthesized. As can be appreciated by the skilled artisan, further methods of synthesizing the compounds of the formulae herein will be evident to those of ordinary skill in the art. Additionally, the various synthetic steps may be performed in an alternate sequence or order to give the desired compounds. Synthetic chemistry transformations and protecting group methodologies (protection and deprotection) useful in synthesizing the compounds described herein are known in the art and include, for example, those such as described in R. Larock, *Comprehensive Organic Transformations*, 2nd. Ed., Wiley-VCH Publishers (1999); T.W. Greene and P.G.M. Wuts, *Protective Groups in Organic Synthesis*, 3rd. Ed., John Wiley and Sons (1999); L. Fieser

2019203664 24 May 2019

and M. Fieser, *Fieser and Fieser's Reagents for Organic Synthesis*, John Wiley and Sons (1999); and L. Paquette, ed., *Encyclopedia of Reagents for Organic Synthesis*, John Wiley and Sons (1995), and subsequent editions thereof.

The additional agents that may be included with the tumor specific neo-antigenic peptides of this invention may contain one or more asymmetric centers and thus occur as racemates and racemic mixtures, single enantiomers, individual diastereomers and diastereomeric mixtures. All such isomeric forms of these compounds are expressly included in the present invention. The compounds of this invention may also be represented in multiple tautomeric forms, in such instances, the invention expressly includes all tautomeric forms of the compounds described herein (e.g., alkylation of a ring system may result in alkylation at multiple sites, the invention expressly includes all such reaction products). All such isomeric forms of such compounds are expressly included in the present invention. All crystal forms of the compounds described herein are expressly included in the present invention.

Preferred unit dosage formulations are those containing a daily dose or unit, daily sub-dose, as hereinabove recited, or an appropriate fraction thereof, of the administered ingredient.

The dosage regimen for treating a disorder or a disease with the tumor specific neo-antigenic peptides of this invention and/or compositions of this invention is based on a variety of factors, including the type of disease, the age, weight, sex, medical condition of the patient, the severity of the condition, the route of administration, and the particular compound employed.

20 Thus, the dosage regimen may vary widely, but can be determined routinely using standard methods.

The amounts and dosage regimens administered to a subject will depend on a number of factors, such as the mode of administration, the nature of the condition being treated, the body weight of the subject being treated and the judgment of the prescribing physician.

25 The amount of compound included within therapeutically active formulations according to the present invention is an effective amount for treating the disease or condition. In general, a therapeutically effective amount of the present preferred compound in dosage form usually ranges from slightly less than about 0.025 mg/kg/day to about 2.5 g/kg/day, preferably about 0.1

2019203664 24 May 2019

mg/kg/day to about 100 mg/kg/day of the patient or considerably more, depending upon the compound used, the condition or infection treated and the route of administration, although exceptions to this dosage range may be contemplated by the present invention. In its most preferred form, compounds according to the present invention are administered in amounts ranging from about 1 mg/kg/day to about 100 mg/kg/day. The dosage of the compound will depend on the condition being treated, the particular compound, and other clinical factors such as weight and condition of the patient and the route of administration of the compound. It is to be understood that the present invention has application for both human and veterinary use.

For oral administration to humans, a dosage of between approximately 0.1 to 100 mg/kg/day, preferably between approximately 1 and 100 mg/kg/day, is generally sufficient.

Where drug delivery is systemic rather than topical, this dosage range generally produces effective blood level concentrations of active compound ranging from less than about 0.04 to about 400 micrograms/cc or more of blood in the patient.

The compound is conveniently administered in any suitable unit dosage form, including but not limited to one containing 0.001 to 3000 mg, preferably 0.05 to 500 mg of active ingredient per unit dosage form. An oral dosage of 10-250 mg is usually convenient.

The concentration of active compound in the drug composition will depend on absorption, distribution, inactivation, and excretion rates of the drug as well as other factors known to those of skill in the art. It is to be noted that dosage values will also vary with the severity of the condition to be alleviated. It is to be further understood that for any particular subject, specific dosage regimens should be adjusted over time according to the individual need and the professional judgment of the person administering or supervising the administration of the compositions, and that the concentration ranges set forth herein are exemplary only and are not intended to limit the scope or practice of the claimed composition. The active ingredient may be administered at once, or may be divided into a number of smaller doses to be administered at varying intervals of time.

In certain embodiments, the compound is administered once daily; in other embodiments, the compound is administered twice daily; in yet other embodiments, the compound is

24 May 2019

2019203664

administered once every two days, once every three days, once every four days, once every five days, once every six days, once every seven days, once every two weeks, once every three weeks, once every four weeks, once every two months, once every six months, or once per year. The dosing interval can be adjusted according to the needs of individual patients. For longer intervals of administration, extended release or depot formulations can be used.

The compounds of the invention can be used to treat diseases and disease conditions that are acute, and may also be used for treatment of chronic conditions. In certain embodiments, the compounds of the invention are administered for time periods exceeding two weeks, three weeks, one month, two months, three months, four months, five months, six months, one year, two years, three years, four years, or five years, ten years, or fifteen years; or for example, any time period range in days, months or years in which the low end of the range is any time period between 14 days and 15 years and the upper end of the range is between 15 days and 20 years (e.g., 4 weeks and 15 years, 6 months and 20 years). In some cases, it may be advantageous for the compounds of the invention to be administered for the remainder of the patient's life. In preferred embodiments, the patient is monitored to check the progression of the disease or disorder, and the dose is adjusted accordingly. In preferred embodiments, treatment according to the invention is effective for at least two weeks, three weeks, one month, two months, three months, four months, five months, six months, one year, two years, three years, four years, or five years, ten years, fifteen years, twenty years, or for the remainder of the subject's life.

The invention provides for pharmaceutical compositions containing at least one tumor specific neo-antigen described herein. In embodiments, the pharmaceutical compositions contain a pharmaceutically acceptable carrier, excipient, or diluent, which includes any pharmaceutical agent that does not itself induce the production of an immune response harmful to a subject receiving the composition, and which may be administered without undue toxicity. As used herein, the term "pharmaceutically acceptable" means being approved by a regulatory agency of the Federal or a state government or listed in the U.S. Pharmacopia, European Pharmacopia or other generally recognized pharmacopia for use in mammals, and more particularly in humans. These compositions can be useful for treating and/or preventing viral infection and/or autoimmune disease.

25

2019203664 24 May 2019

A thorough discussion of pharmaceutically acceptable carriers, diluents, and other excipients is presented in *Remington's Pharmaceutical Sciences* (17th ed., Mack Publishing Company) and *Remington: The Science and Practice of Pharmacy* (21st ed., Lippincott Williams & Wilkins), which are hereby incorporated by reference. The formulation of the pharmaceutical composition should suit the mode of administration. In embodiments, the pharmaceutical composition is suitable for administration to humans, and can be sterile, non-particulate and/or non-pyrogenic.

Pharmaceutically acceptable carriers, excipients, or diluents include, but are not limited, to saline, buffered saline, dextrose, water, glycerol, ethanol, sterile isotonic aqueous buffer, and combinations thereof.

Wetting agents, emulsifiers and lubricants, such as sodium lauryl sulfate and magnesium stearate, as well as coloring agents, release agents, coating agents, sweetening, flavoring and perfuming agents, preservatives, and antioxidants can also be present in the compositions.

Examples of pharmaceutically-acceptable antioxidants include, but are not limited to: (1) water soluble antioxidants, such as ascorbic acid, cysteine hydrochloride, sodium bisulfate, sodium metabisulfite, sodium sulfite and the like; (2) oil-soluble antioxidants, such as ascorbyl palmitate, butylated hydroxyanisole (BHA), butylated hydroxytoluene (BHT), lecithin, propyl gallate, alpha-tocopherol, and the like; and (3) metal chelating agents, such as citric acid, ethylenediamine tetraacetic acid (EDTA), sorbitol, tartaric acid, phosphoric acid, and the like.

20 In embodiments, the pharmaceutical composition is provided in a solid form, such as a lyophilized powder suitable for reconstitution, a liquid solution, suspension, emulsion, tablet, pill, capsule, sustained release formulation, or powder.

25 In embodiments, the pharmaceutical composition is supplied in liquid form, for example, in a sealed container indicating the quantity and concentration of the active ingredient in the pharmaceutical composition. In related embodiments, the liquid form of the pharmaceutical composition is supplied in a hermetically sealed container.

Methods for formulating the pharmaceutical compositions of the present invention are conventional and well known in the art (see Remington and Remington's). One of skill in the art

2019203664 24 May 2019

can readily formulate a pharmaceutical composition having the desired characteristics (e.g., route of administration, biosafety, and release profile).

Methods for preparing the pharmaceutical compositions include the step of bringing into association the active ingredient with a pharmaceutically acceptable carrier and, optionally, one or more accessory ingredients. The pharmaceutical compositions can be prepared by uniformly and intimately bringing into association the active ingredient with liquid carriers, or finely divided solid carriers, or both, and then, if necessary, shaping the product. Additional methodology for preparing the pharmaceutical compositions, including the preparation of multilayer dosage forms, are described in *Ansel's Pharmaceutical Dosage Forms and Drug Delivery Systems* (9th ed., Lippincott Williams & Wilkins), which is hereby incorporated by reference.

Pharmaceutical compositions suitable for oral administration can be in the form of capsules, cachets, pills, tablets, lozenges (using a flavored basis, usually sucrose and acacia or tragacanth), powders, granules, or as a solution or a suspension in an aqueous or non-aqueous liquid, or as an oil-in-water or water-in-oil liquid emulsion, or as an elixir or syrup, or as pastilles (using an inert base, such as gelatin and glycerin, or sucrose and acacia) and/or as mouth washes and the like, each containing a predetermined amount of a compound(s) described herein, a derivative thereof, or a pharmaceutically acceptable salt or prodrug thereof as the active ingredient(s). The active ingredient can also be administered as a bolus, electuary, or paste.

20 In solid dosage forms for oral administration (e.g., capsules, tablets, pills, dragees,  
powders, granules and the like), the active ingredient is mixed with one or more  
pharmaceutically acceptable carriers, excipients, or diluents, such as sodium citrate or dicalcium  
phosphate, and/or any of the following: (1) fillers or extenders, such as starches, lactose, sucrose,  
glucose, mannitol, and/or silicic acid; (2) binders, such as, for example, carboxymethylcellulose,  
25 alginates, gelatin, polyvinyl pyrrolidone, sucrose and/or acacia; (3) humectants, such as glycerol;  
(4) disintegrating agents, such as agar-agar, calcium carbonate, potato or tapioca starch, alginic  
acid, certain silicates, and sodium carbonate; (5) solution retarding agents, such as paraffin; (6)  
absorption accelerators, such as quaternary ammonium compounds; (7) wetting agents, such as,  
for example, acetyl alcohol and glycerol monostearate; (8) absorbents, such as kaolin and

2019203664  
24 May 2019

bentonite clay; (9) lubricants, such as talc, calcium stearate, magnesium stearate, solid polyethylene glycols, sodium lauryl sulfate, and mixtures thereof; and (10) coloring agents. In the case of capsules, tablets, and pills, the pharmaceutical compositions can also comprise buffering agents. Solid compositions of a similar type can also be prepared using fillers in soft and hard-filled gelatin capsules, and excipients such as lactose or milk sugars, as well as high molecular weight polyethylene glycols and the like.

A tablet can be made by compression or molding, optionally with one or more accessory ingredients. Compressed tablets can be prepared using binders (for example, gelatin or hydroxypropylmethyl cellulose), lubricants, inert diluents, preservatives, disintegrants (for example, sodium starch glycolate or cross-linked sodium carboxymethyl cellulose), surface-active, and/or dispersing agents. Molded tablets can be made by molding in a suitable machine a mixture of the powdered active ingredient moistened with an inert liquid diluent.

The tablets and other solid dosage forms, such as dragees, capsules, pills, and granules, can optionally be scored or prepared with coatings and shells, such as enteric coatings and other coatings well known in the art.

In some embodiments, in order to prolong the effect of an active ingredient, it is desirable to slow the absorption of the compound from subcutaneous or intramuscular injection. This can be accomplished by the use of a liquid suspension of crystalline or amorphous material having poor water solubility. The rate of absorption of the active ingredient then depends upon its rate of dissolution which, in turn, can depend upon crystal size and crystalline form. Alternatively, delayed absorption of a parenterally-administered active ingredient is accomplished by dissolving or suspending the compound in an oil vehicle. In addition, prolonged absorption of the injectable pharmaceutical form can be brought about by the inclusion of agents that delay absorption such as aluminum monostearate and gelatin.

Controlled release parenteral compositions can be in form of aqueous suspensions, microspheres, microcapsules, magnetic microspheres, oil solutions, oil suspensions, emulsions, or the active ingredient can be incorporated in biocompatible carrier(s), liposomes, nanoparticles, implants or infusion devices.

2019203664 24 May 2019

Materials for use in the preparation of microspheres and/or microcapsules include biodegradable/bioerodible polymers such as polyglactin, poly-(isobutyl cyanoacrylate), poly(2-hydroxyethyl-L-glutamine) and poly(lactic acid).

Biocompatible carriers which can be used when formulating a controlled release parenteral formulation include carbohydrates such as dextrans, proteins such as albumin, lipoproteins or antibodies.

Materials for use in implants can be non-biodegradable, e.g., polydimethylsiloxane, or biodegradable such as, e.g., poly(caprolactone), poly(lactic acid), poly(glycolic acid) or poly(ortho esters).

In embodiments, the active ingredient(s) are administered by aerosol. This is accomplished by preparing an aqueous aerosol, liposomal preparation, or solid particles containing the compound. A nonaqueous (*e.g.*, fluorocarbon propellant) suspension can be used. The pharmaceutical composition can also be administered using a sonic nebulizer, which would minimize exposing the agent to shear, which can result in degradation of the compound.

Ordinarily, an aqueous aerosol is made by formulating an aqueous solution or suspension of the active ingredient(s) together with conventional pharmaceutically-acceptable carriers and stabilizers. The carriers and stabilizers vary with the requirements of the particular compound, but typically include nonionic surfactants (Tweens, Pluronic, or polyethylene glycol), innocuous proteins like serum albumin, sorbitan esters, oleic acid, lecithin, amino acids such as glycine, buffers, salts, sugars or sugar alcohols. Aerosols generally are prepared from isotonic solutions.

Dosage forms for topical or transdermal administration of an active ingredient(s) includes powders, sprays, ointments, pastes, creams, lotions, gels, solutions, patches and inhalants. The active ingredient(s) can be mixed under sterile conditions with a pharmaceutically acceptable carrier, and with any preservatives, buffers, or propellants as appropriate.

Transdermal patches suitable for use in the present invention are disclosed in *Transdermal Drug Delivery: Developmental Issues and Research Initiatives* (Marcel Dekker Inc., 1989) and U.S. Pat. Nos. 4,743,249, 4,906,169, 5,198,223, 4,816,540, 5,422,119, 5,023,084, which are hereby incorporated by reference. The transdermal patch can also be any transdermal



2019203664  
24 May 2019

patch well known in the art, including transscrotal patches. Pharmaceutical compositions in such transdermal patches can contain one or more absorption enhancers or skin permeation enhancers well known in the art (*see, e.g.*, U.S. Pat. Nos. 4,379,454 and 4,973,468, which are hereby incorporated by reference). Transdermal therapeutic systems for use in the present invention can be based on iontophoresis, diffusion, or a combination of these two effects.

Transdermal patches have the added advantage of providing controlled delivery of active ingredient(s) to the body. Such dosage forms can be made by dissolving or dispersing the active ingredient(s) in a proper medium. Absorption enhancers can also be used to increase the flux of the active ingredient across the skin. The rate of such flux can be controlled by either providing a rate controlling membrane or dispersing the active ingredient(s) in a polymer matrix or gel.

Such pharmaceutical compositions can be in the form of creams, ointments, lotions, liniments, gels, hydrogels, solutions, suspensions, sticks, sprays, pastes, plasters and other kinds of transdermal drug delivery systems. The compositions can also include pharmaceutically acceptable carriers or excipients such as emulsifying agents, antioxidants, buffering agents, preservatives, humectants, penetration enhancers, chelating agents, gel-forming agents, ointment bases, perfumes, and skin protective agents.

Examples of emulsifying agents include, but are not limited to, naturally occurring gums, e.g. gum acacia or gum tragacanth, naturally occurring phosphatides, e.g. soybean lecithin and sorbitan monooleate derivatives.

20 Examples of antioxidants include, but are not limited to, butylated hydroxy anisole (BHA), ascorbic acid and derivatives thereof, tocopherol and derivatives thereof, and cysteine.

Examples of preservatives include, but are not limited to, parabens, such as methyl or propyl p-hydroxybenzoate and benzalkonium chloride.

25 Examples of humectants include, but are not limited to, glycerin, propylene glycol, sorbitol and urea.

Examples of penetration enhancers include, but are not limited to, propylene glycol, DMSO, triethanolamine, N,N-dimethylacetamide, N,N-dimethylformamide, 2-pyrrolidone and

2019203664 24 May 2019

derivatives thereof, tetrahydrofurfuryl alcohol, propylene glycol, diethylene glycol monoethyl or monomethyl ether with propylene glycol monolaurate or methyl laurate, eucalyptol, lecithin, Transcutol<sup>®</sup>, and Azone<sup>®</sup>.

Examples of chelating agents include, but are not limited to, sodium EDTA, citric acid and phosphoric acid.

Examples of gel forming agents include, but are not limited to, Carbopol, cellulose derivatives, bentonite, alginates, gelatin and polyvinylpyrrolidone.

In addition to the active ingredient(s), the ointments, pastes, creams, and gels of the present invention can contain excipients, such as animal and vegetable fats, oils, waxes, paraffins, starch, tragacanth, cellulose derivatives, polyethylene glycols, silicones, bentonites, silicic acid, talc and zinc oxide, or mixtures thereof.

Powders and sprays can contain excipients such as lactose, talc, silicic acid, aluminum hydroxide, calcium silicates and polyamide powder, or mixtures of these substances. Sprays can additionally contain customary propellants, such as chlorofluorohydrocarbons, and volatile unsubstituted hydrocarbons, such as butane and propane.

Injectable depot forms are made by forming microencapsule matrices of compound(s) of the invention in biodegradable polymers such as polylactide-polyglycolide. Depending on the ratio of compound to polymer, and the nature of the particular polymer employed, the rate of compound release can be controlled. Examples of other biodegradable polymers include poly(orthoesters) and poly(anhydrides). Depot injectable formulations are also prepared by entrapping the drug in liposomes or microemulsions which are compatible with body tissue.

Subcutaneous implants are well known in the art and are suitable for use in the present invention. Subcutaneous implantation methods are preferably non-irritating and mechanically resilient. The implants can be of matrix type, of reservoir type, or hybrids thereof. In matrix type devices, the carrier material can be porous or non-porous, solid or semi-solid, and permeable or impermeable to the active compound or compounds. The carrier material can be biodegradable or may slowly erode after administration. In some instances, the matrix is non-degradable but instead relies on the diffusion of the active compound through the matrix for the

24 May 2019

2019203664

carrier material to degrade. Alternative subcutaneous implant methods utilize reservoir devices where the active compound or compounds are surrounded by a rate controlling membrane, e.g., a membrane independent of component concentration (possessing zero-order kinetics). Devices consisting of a matrix surrounded by a rate controlling membrane also suitable for use.

Both reservoir and matrix type devices can contain materials such as polydimethylsiloxane, such as Silastic™, or other silicone rubbers. Matrix materials can be insoluble polypropylene, polyethylene, polyvinyl chloride, ethylvinyl acetate, polystyrene and polymethacrylate, as well as glycerol esters of the glycerol palmitostearate, glycerol stearate, and glycerol behenate type. Materials can be hydrophobic or hydrophilic polymers and optionally contain solubilizing agents.

Subcutaneous implant devices can be slow-release capsules made with any suitable polymer, e.g., as described in U.S. Pat. Nos. 5,035,891 and 4,210,644, which are hereby incorporated by reference.

In general, at least four different approaches are applicable in order to provide rate control over the release and transdermal permeation of a drug compound. These approaches are: membrane-moderated systems, adhesive diffusion-controlled systems, matrix dispersion-type systems and microreservoir systems. It is appreciated that a controlled release percutaneous and/or topical composition can be obtained by using a suitable mixture of these approaches.

20 In a membrane-moderated system, the active ingredient is present in a reservoir which is totally encapsulated in a shallow compartment molded from a drug-impermeable laminate, such as a metallic plastic laminate, and a rate-controlling polymeric membrane such as a microporous or a non-porous polymeric membrane, e.g., ethylene-vinyl acetate copolymer. The active ingredient is released through the rate controlling polymeric membrane. In the drug reservoir, the active ingredient can either be dispersed in a solid polymer matrix or suspended in an  
25 unleachable, viscous liquid medium such as silicone fluid. On the external surface of the polymeric membrane, a thin layer of an adhesive polymer is applied to achieve an intimate contact of the transdermal system with the skin surface. The adhesive polymer is preferably a polymer which is hypoallergenic and compatible with the active drug substance.

24 May 2019

2019203664

In an adhesive diffusion-controlled system, a reservoir of the active ingredient is formed by directly dispersing the active ingredient in an adhesive polymer and then by, e.g., solvent casting, spreading the adhesive containing the active ingredient onto a flat sheet of substantially drug-impermeable metallic plastic backing to form a thin drug reservoir layer.

A matrix dispersion-type system is characterized in that a reservoir of the active ingredient is formed by substantially homogeneously dispersing the active ingredient in a hydrophilic or lipophilic polymer matrix. The drug-containing polymer is then molded into disc with a substantially well-defined surface area and controlled thickness. The adhesive polymer is spread along the circumference to form a strip of adhesive around the disc.

A microreservoir system can be considered as a combination of the reservoir and matrix dispersion type systems. In this case, the reservoir of the active substance is formed by first suspending the drug solids in an aqueous solution of water-soluble polymer and then dispersing the drug suspension in a lipophilic polymer to form a multiplicity of unleachable, microscopic spheres of drug reservoirs.

Any of the above-described controlled release, extended release, and sustained release compositions can be formulated to release the active ingredient in about 30 minutes to about 1 week, in about 30 minutes to about 72 hours, in about 30 minutes to 24 hours, in about 30 minutes to 12 hours, in about 30 minutes to 6 hours, in about 30 minutes to 4 hours, and in about 3 hours to 10 hours. In embodiments, an effective concentration of the active ingredient(s) is sustained in a subject for 4 hours, 6 hours, 8 hours, 10 hours, 12 hours, 16 hours, 24 hours, 48 hours, 72 hours, or more after administration of the pharmaceutical compositions to the subject.

## Dosages

When the agents described herein are administered as pharmaceuticals to humans or animals, they can be given per se or as a pharmaceutical composition containing active ingredient in combination with a pharmaceutically acceptable carrier, excipient, or diluent.

2019203664  
24 May 2019

Actual dosage levels and time course of administration of the active ingredients in the pharmaceutical compositions of the invention can be varied so as to obtain an amount of the active ingredient which is effective to achieve the desired therapeutic response for a particular patient, composition, and mode of administration, without being toxic to the patient. Generally, agents or pharmaceutical compositions of the invention are administered in an amount sufficient to reduce or eliminate symptoms associated with viral infection and/or autoimmune disease.

Exemplary dose ranges include 0.01 mg to 250 mg per day, 0.01 mg to 100 mg per day, 1 mg to 100 mg per day, 10 mg to 100 mg per day, 1 mg to 10 mg per day, and 0.01 mg to 10 mg per day. A preferred dose of an agent is the maximum that a patient can tolerate and not develop serious or unacceptable side effects. In embodiments, the agent is administered at a concentration of about 10 micrograms to about 100 mg per kilogram of body weight per day, about 0.1 to about 10 mg/kg per day, or about 1.0 mg to about 10 mg/kg of body weight per day.

In embodiments, the pharmaceutical composition comprises an agent in an amount ranging between 1 and 10 mg, such as 1, 2, 3, 4, 5, 6, 7, 8, 9, or 10 mg.

In embodiments, the therapeutically effective dosage produces a serum concentration of an agent of from about 0.1 ng/ml to about 50-100  $\mu$ g/ml. The pharmaceutical compositions typically should provide a dosage of from about 0.001 mg to about 2000 mg of compound per kilogram of body weight per day. For example, dosages for systemic administration to a human patient can range from 1-10  $\mu$ g/kg, 20-80  $\mu$ g/kg, 5-50  $\mu$ g/kg, 75-150  $\mu$ g/kg, 100-500  $\mu$ g/kg, 250-750  $\mu$ g/kg, 500-1000  $\mu$ g/kg, 1-10 mg/kg, 5-50 mg/kg, 25-75 mg/kg, 50-100 mg/kg, 100-250 mg/kg, 50-100 mg/kg, 250-500 mg/kg, 500-750 mg/kg, 750-1000 mg/kg, 1000-1500 mg/kg, 1500-2000 mg/kg, 5 mg/kg, 20 mg/kg, 50 mg/kg, 100 mg/kg, 500 mg/kg, 1000 mg/kg, 1500 mg/kg, or 2000 mg/kg. Pharmaceutical dosage unit forms are prepared to provide from about 1 mg to about 5000 mg, for example from about 100 to about 2500 mg of the compound or a combination of essential ingredients per dosage unit form.

In embodiments, about 50 nM to about 1  $\mu$ M of an agent is administered to a subject. In related embodiments, about 50-100 nM, 50-250 nM, 100-500 nM, 250-500 nM, 250-750 nM, 500-750 nM, 500 nM to 1  $\mu$ M, or 750 nM to 1  $\mu$ M of an agent is administered to a subject.

2019203664 24 May 2019

Determination of an effective amount is well within the capability of those skilled in the art, especially in light of the detailed disclosure provided herein. Generally, an efficacious or effective amount of an agent is determined by first administering a low dose of the agent(s) and then incrementally increasing the administered dose or dosages until a desired effect (e.g., reduce or eliminate symptoms associated with viral infection or autoimmune disease) is observed in the treated subject, with minimal or acceptable toxic side effects. Applicable methods for determining an appropriate dose and dosing schedule for administration of a pharmaceutical composition of the present invention are described, for example, in *Goodman and Gilman's The Pharmacological Basis of Therapeutics*, Goodman *et al.*, eds., 11th Edition, McGraw-Hill 2005, and *Remington: The Science and Practice of Pharmacy*, 20th and 21st Editions, Gennaro and University of the Sciences in Philadelphia, Eds., Lippencott Williams & Wilkins (2003 and 2005), each of which is hereby incorporated by reference.

### **Combination Therapies**

The tumor specific neo-antigen peptides and pharmaceutical compositions described herein can also be administered in combination with another therapeutic molecule. The therapeutic molecule can be any compound used to mitigate neoplasia, or symptoms thereof. Examples of such compounds include, but are not limited to, chemotherapeutic agents, anti—angiogenesis agents, checkpoint blockade antibodies or other molecules that reduce immune-suppression, and the like.

20 The tumor specific neo-antigen peptides can be administered before, during, or after administration of the additional therapeutic agent. In embodiments, the tumor specific neo-antigen peptides are administered before the first administration of the additional therapeutic agent. In  
25 embodiments, the tumor specific neo-antigen peptides are administered after the first administration of the additional therapeutic agent (e.g., 1, 2, 3, 4, 5, 6, 7, 8, 9, 10, 11, 12, 13, 14 days or more). In  
embodiments, the tumor specific neo-antigen peptides are administered simultaneously with the first administration of the additional therapeutic agent.

### **Vaccines**

In an exemplary embodiment, the present invention is directed to an immunogenic composition, e.g., a vaccine composition capable of raising a specific T-cell response. The

2019203664 24 May 2019

vaccine composition comprises mutant neo-antigenic peptides and mutant neo-antigenic polypeptides corresponding to tumor specific neo-antigens identified by the methods described herein.

A suitable vaccine will preferably contain a plurality of tumor specific neo-antigenic peptides. In an embodiment, the vaccine will include between 1 and 100 sets peptides, more preferably between 1 and 50 such peptides, even more preferably between 10 and 30 sets peptides, even more preferably between 15 and 25 peptides. According to another preferred embodiment, the vaccine will include approximately 20 peptides, more preferably 5, 6, 7, 8, 9, 10, 11, 12, 13, 14, 15, 16, 17, 18, 19, 20, 21, 22, 23, 24, 25, 26, 27, 28, 29, or 30 different peptides, further preferred 6, 7, 8, 9, 10 11, 12, 13, 14, 15, 16, 17, 18, 19, 20, 21, 22, 23, 24, or 25 different peptides, and most preferably 18, 19, 20, 21, 22, 23, 24, or 25 different peptides.

In one embodiment of the present invention the different tumor specific neo-antigenic peptides and/or polypeptides are selected for use in the neoplasia vaccine so as to maximize the likelihood of generating an immune attack against the neoplasia/tumor of the patient. Without being bound by theory, it is believed that the inclusion of a diversity of tumor specific neo-antigenic peptides will generate a broad scale immune attack against a neoplasia/tumor. In one embodiment, the selected tumor specific neo-antigenic peptides/polypeptides are encoded by missense mutations. In a second embodiment, the selected tumor specific neo-antigenic peptides/polypeptides are encoded by a combination of missense mutations and neoORF mutations. In a third embodiment, the selected tumor specific neo-antigenic peptides/polypeptides are encoded by neoORF mutations.

In one embodiment in which the selected tumor specific neo-antigenic peptides/polypeptides are encoded by missense mutations, the peptides and/or polypeptides are chosen based on their capability to associate with the particular MHC molecules of the patient. 25 Peptides/polypeptides derived from neoORF mutations can also be selected on the basis of their capability to associate with the particular MHC molecules of the patient, but can also be selected even if not predicted to associate with the particular MHC molecules of the patient.

The vaccine composition is capable of raising a specific cytotoxic T-cells response and/or a specific helper T-cell response.

30 The vaccine composition can further comprise an adjuvant and/or a carrier. Examples of useful adjuvants and carriers are given herein below. The peptides and/or polypeptides in the

2019203664  
24 May 2019

composition can be associated with a carrier such as, e.g., a protein or an antigen-presenting cell such as e.g. a dendritic cell (DC) capable of presenting the peptide to a T-cell.

Adjuvants are any substance whose admixture into the vaccine composition increases or otherwise modifies the immune response to the mutant peptide. Carriers are scaffold structures, for example a polypeptide or a polysaccharide, to which the neo-antigenic peptides, is capable of being associated. Optionally, adjuvants are conjugated covalently or non-covalently to the peptides or polypeptides of the invention.

The ability of an adjuvant to increase the immune response to an antigen is typically manifested by a significant increase in immune-mediated reaction, or reduction in disease symptoms. For example, an increase in humoral immunity is typically manifested by a significant increase in the titer of antibodies raised to the antigen, and an increase in T-cell activity is typically manifested in increased cell proliferation, or cellular cytotoxicity, or cytokine secretion. An adjuvant may also alter an immune response, for example, by changing a primarily humoral or Th2 response into a primarily cellular, or Th1 response.

Suitable adjuvants include, but are not limited to 1018 ISS, aluminum salts, Amplivax, AS15, BCG, CP-870,893, CpG7909, CyaA, dSLIM, GM-CSF, IC30, IC31, Imiquimod, ImuFact IMP321, IS Patch, ISS, ISCOMATRIX, JuvImmune, LipoVac, MF59, monophosphoryl lipid A, Montanide IMS 1312, Montanide ISA 206, Montanide ISA 50V, Montanide ISA-51, OK-432, OM-174, OM-197-MP-EC, ONTAK, PepTel.RTM. vector system, PLG microparticles, resiquimod, SRL172, Virosomes and other Virus-like particles, YF-17D, VEGF trap, R848, beta-glucan, Pam3Cys, Aquila's QS21 stimulon (Aquila Biotech, Worcester, Mass., USA) which is derived from saponin, mycobacterial extracts and synthetic bacterial cell wall mimics, and other proprietary adjuvants such as Ribi's Detox. Quil or Superfos. Several immunological adjuvants (e.g., MF59) specific for dendritic cells and their preparation have been described previously (Dupuis M, et al., Cell Immunol. 1998; 186(1): 18-27; Allison A C; Dev Biol Stand. 1998; 92:3-11). Also cytokines may be used. Several cytokines have been directly linked to influencing dendritic cell migration to lymphoid tissues (e.g., TNF-alpha), accelerating the maturation of dendritic cells into efficient antigen-presenting cells for T-lymphocytes (e.g., GM-CSF, IL-1 and IL-4) (U.S. Pat. No. 5,849,589, specifically incorporated herein by reference in its entirety) and acting as immunoadjuvants (e.g., IL-12) (Gabrilovich D I, et al., J Immunother Emphasis Tumor Immunol. 1996 (6):414-418).

25

30



2019203664 24 May 2019

Toll like receptors (TLRs) may also be used as adjuvants, and are important members of the family of pattern recognition receptors (PRRs) which recognize conserved motifs shared by many micro-organisms, termed “pathogen-associated molecular patterns” (PAMPS). Recognition of these “danger signals” activates multiple elements of the innate and adaptive immune system. TLRs are expressed by cells of the innate and adaptive immune systems such as dendritic cells (DCs), macrophages, T and B cells, mast cells, and granulocytes and are localized in different cellular compartments, such as the plasma membrane, lysosomes, endosomes, and endolysosomes. Different TLRs recognize distinct PAMPS. For example, TLR4 is activated by LPS contained in bacterial cell walls, TLR9 is activated by unmethylated bacterial or viral CpG DNA, and TLR3 is activated by double stranded RNA. TLR ligand binding leads to the activation of one or more intracellular signaling pathways, ultimately resulting in the production of many key molecules associated with inflammation and immunity (particularly the transcription factor NF- $\kappa$ B and the Type-I interferons). TLR mediated DC activation leads to enhanced DC activation, phagocytosis, upregulation of activation and co-stimulation markers such as CD80, CD83, and CD86, expression of CCR7 allowing migration of DC to draining lymph nodes and facilitating antigen presentation to T cells, as well as increased secretion of cytokines such as type I interferons, IL-12, and IL-6. All of these downstream events are critical for the induction of an adaptive immune response.

Among the most promising cancer vaccine adjuvants currently in clinical development are the TLR9 agonist CpG and the synthetic double-stranded RNA (dsRNA) TLR3 ligand poly-ICLC. In preclinical studies poly-ICLC appears to be the most potent TLR adjuvant when compared to LPS and CpG due to its induction of pro-inflammatory cytokines and lack of stimulation of IL-10, as well as maintenance of high levels of co-stimulatory molecules in DCs. Furthermore, poly-ICLC was recently directly compared to CpG in non-human primates (rhesus macaques) as adjuvant for a protein vaccine consisting of human papillomavirus (HPV)16 capsomers (Stahl-Hennig C, Eisenblatter M, Jasny E, et al. Synthetic double-stranded RNAs are adjuvants for the induction of T helper 1 and humoral immune responses to human papillomavirus in rhesus macaques. PLoS pathogens. Apr 2009;5(4)).

CpG immuno stimulatory oligonucleotides have also been reported to enhance the effects of adjuvants in a vaccine setting. Without being bound by theory, CpG oligonucleotides act by activating the innate (non- adaptive) immune system via Toll-like receptors (TLR), mainly

2019203664  
24 May 2019

2019203664

TLR9. CpG triggered TLR9 activation enhances antigen- specific humoral and cellular responses to a wide variety of antigens, including peptide or protein antigens, live or killed viruses, dendritic cell vaccines, autologous cellular vaccines and polysaccharide conjugates in both prophylactic and therapeutic vaccines. More importantly, it enhances dendritic cell maturation and differentiation, resulting in enhanced activation of Th1 cells and strong cytotoxic T- lymphocyte (CTL) generation, even in the absence of CD4 T-cell help. The Th1 bias induced by TLR9 stimulation is maintained even in the presence of vaccine adjuvants such as alum or incomplete Freund's adjuvant (IFA) that normally promote a Th2 bias. CpG oligonucleotides show even greater adjuvant activity when formulated or co-administered with other adjuvants or in formulations such as microparticles, nano particles, lipid emulsions or similar formulations, which are especially necessary for inducing a strong response when the antigen is relatively weak. They also accelerate the immune response and enabled the antigen doses to be reduced by approximately two orders of magnitude, with comparable antibody responses to the full-dose vaccine without CpG in some experiments (Arthur M. Krieg, Nature Reviews, Drug Discovery, 5, Jun. 2006, 471-484). U.S. Pat. No. 6,406,705 B1 describes the combined use of CpG oligonucleotides, non-nucleic acid adjuvants and an antigen to induce an antigen- specific immune response. A commercially available CpG TLR9 antagonist is dSLIM (double Stem Loop Immunomodulator) by Mologen (Berlin, GERMANY), which is a preferred component of the pharmaceutical composition of the present invention. Other TLR binding molecules such as RNA binding TLR 7, TLR 8 and/or TLR 9 may also be used.

Xanthenone derivatives such as, for example, Vadimezan or AsA404 (also known as 5,6-dimethylxanthenone-4-acetic acid (DMXAA)), may also be used as adjuvants according to embodiments of the invention. Alternatively, such derivatives may also be administered in parallel to the vaccine of the invention, for example via systemic or intratumoral delivery, to stimulate immunity at the tumor site. Without being bound by theory, it is believed that such xanthenone derivatives act by stimulating interferon (IFN) production via the stimulator of IFN gene (STING) receptor (see e.g., Conlon et al. (2013) Mouse, but not Human STING, Binds and Signals in Response to the Vascular Disrupting Agent 5,6-Dimethylxanthenone-4-Acetic Acid, Journal of Immunology, 190:5216-25 and Kim et al. (2013) Anticancer Flavonoids are Mouse- Selective STING Agonists, 8:1396-1401).

2019203664 24 May 2019

Other examples of useful adjuvants include, but are not limited to, chemically modified CpGs (e.g. CpR, Idera), Poly(I:C)(e.g. poly:CI2U), non-CpG bacterial DNA or RNA as well as immunoactive small molecules and antibodies such as cyclophosphamide, sunitinib, bevacizumab, celebrex, NCX-4016, sildenafil, tadalafil, vardenafil, sorafenib, XL-999, CP-547632, pazopanib, ZD2171, AZD2171, ipilimumab, tremelimumab, and SC58175, which may act therapeutically and/or as an adjuvant. The amounts and concentrations of adjuvants and additives useful in the context of the present invention can readily be determined by the skilled artisan without undue experimentation. Additional adjuvants include colony-stimulating factors, such as Granulocyte Macrophage Colony Stimulating Factor (GM-CSF, sargramostim).

Poly-ICLC is a synthetically prepared double-stranded RNA consisting of polyI and polyC strands of average length of about 5000 nucleotides, which has been stabilized to thermal denaturation and hydrolysis by serum nucleases by the addition of polylysine and carboxymethylcellulose. The compound activates TLR3 and the RNA helicase-domain of MDA5, both members of the PAMP family, leading to DC and natural killer (NK) cell activation and production of a “natural mix” of type I interferons, cytokines, and chemokines. Furthermore, poly-ICLC exerts a more direct, broad host-targeted anti-infectious and possibly antitumor effect mediated by the two IFN-inducible nuclear enzyme systems, the 2'5'-OAS and the P1/eIF2a kinase, also known as the PKR (4-6), as well as RIG-I helicase and MDA5.

In rodents and non-human primates, poly-ICLC was shown to enhance T cell responses to viral antigens, cross-priming, and the induction of tumor-, virus-, and autoantigen-specific CD8<sup>+</sup> T-cells. In a recent study in non-human primates, poly-ICLC was found to be essential for the generation of antibody responses and T-cell immunity to DC targeted or non-targeted HIV Gag p24 protein, emphasizing its effectiveness as a vaccine adjuvant.

25 In human subjects, transcriptional analysis of serial whole blood samples revealed similar gene expression profiles among the 8 healthy human volunteers receiving one single s.c. administration of poly-ICLC and differential expression of up to 212 genes between these 8 subjects versus 4 subjects receiving placebo. Remarkably, comparison of the poly-ICLC gene expression data to previous data from volunteers immunized with the highly effective yellow fever vaccine YF17D showed that a large number of transcriptional and signal transduction  
30 canonical pathways, including those of the innate immune system, were similarly upregulated at peak time points.

2019203664  
24 May 2019

More recently, an immunologic analysis was reported on patients with ovarian, fallopian tube, and primary peritoneal cancer in second or third complete clinical remission who were treated on a phase 1 study of subcutaneous vaccination with synthetic overlapping long peptides (OLP) from the cancer testis antigen NY-ESO-1 alone or with Montanide-ISA-51, or with 1.4 mg poly-ICLC and Montanide. The generation of NY-ESO-1-specific CD4+ and CD8+ T-cell and antibody responses were markedly enhanced with the addition of poly-ICLC and Montanide compared to OLP alone or OLP and Montanide.

A vaccine composition according to the present invention may comprise more than one different adjuvant. Furthermore, the invention encompasses a therapeutic composition comprising any adjuvant substance including any of the above or combinations thereof. It is also contemplated that the peptide or polypeptide, and the adjuvant can be administered separately in any appropriate sequence.

A carrier may be present independently of an adjuvant. The function of a carrier can for example be to confer stability, to increase the biological activity, or to increase serum half-life. Furthermore, a carrier may aid presenting peptides to T-cells. The carrier may be any suitable carrier known to the person skilled in the art, for example a protein or an antigen presenting cell. A carrier protein could be but is not limited to keyhole limpet hemocyanin, serum proteins such as transferrin, bovine serum albumin, human serum albumin, thyroglobulin or ovalbumin, immunoglobulins, or hormones, such as insulin or palmitic acid. For immunization of humans, the carrier may be a physiologically acceptable carrier acceptable to humans and safe. However, tetanus toxoid and/or diphtheria toxoid are suitable carriers in one embodiment of the invention. Alternatively, the carrier may be dextrans for example sepharose.

25 Cytotoxic T-cells (CTLs) recognize an antigen in the form of a peptide bound to an MHC molecule rather than the intact foreign antigen itself. The MHC molecule itself is located at the cell surface of an antigen presenting cell. Thus, an activation of CTLs is only possible if a trimeric complex of peptide antigen, MHC molecule, and APC is present. Correspondingly, it may enhance the immune response if not only the peptide is used for activation of CTLs, but if additionally APCs with the respective MHC molecule are added. Therefore, in some  
30 embodiments the vaccine composition according to the present invention additionally contains at least one antigen presenting cell.

2019203664  
24 May 2019

The antigen-presenting cell (or stimulator cell) typically has an MHC class I or II molecule on its surface, and in one embodiment is substantially incapable of itself loading the MHC class I or II molecule with the selected antigen. As is described in more detail below, the MHC class I or II molecule may readily be loaded with the selected antigen in vitro.

Preferably, the antigen presenting cells are dendritic cells. Suitably, the dendritic cells are autologous dendritic cells that are pulsed with the neo-antigenic peptide. The peptide may be any suitable peptide that gives rise to an appropriate T-cell response. T-cell therapy using autologous dendritic cells pulsed with peptides from a tumor associated antigen is disclosed in Murphy et al. (1996) *The Prostate* 29, 371-380 and Tjua et al. (1997) *The Prostate* 32, 272-278.

Thus, in one embodiment of the present invention the vaccine composition containing at least one antigen presenting cell is pulsed or loaded with one or more peptides of the present invention. Alternatively, peripheral blood mononuclear cells (PBMCs) isolated from a patient may be loaded with peptides ex vivo and injected back into the patient. As an alternative the antigen presenting cell comprises an expression construct encoding a peptide of the present invention. The polynucleotide may be any suitable polynucleotide and it is preferred that it is capable of transducing the dendritic cell, thus resulting in the presentation of a peptide and induction of immunity.

### **Therapeutic Methods**

The invention further provides a method of inducing a neoplasia/tumor specific immune response in a subject, vaccinating against a neoplasia/tumor, treating and or alleviating a symptom of cancer in a subject by administering the subject a neo-antigenic peptide or vaccine composition of the invention.

According to the invention, the above-described cancer vaccine may be used for a patient that has been diagnosed as having cancer, or at risk of developing cancer. In one embodiment, the patient may have a solid tumor such as breast, ovarian, prostate, lung, kidney, gastric, colon, testicular, head and neck, pancreas, brain, melanoma, and other tumors of tissue organs and hematological tumors, such as lymphomas and leukemias, including acute myelogenous leukemia, chronic myelogenous leukemia, chronic lymphocytic leukemia, T cell lymphocytic leukemia, and B cell lymphomas.

The peptide or composition of the invention is administered in an amount sufficient to induce a CTL response.

2019203664  
24 May 2019

2019203664

The neo-antigenic peptide, polypeptide or vaccine composition of the invention can be administered alone or in combination with other therapeutic agents. The therapeutic agent is for example, a chemotherapeutic or biotherapeutic agent, radiation, or immunotherapy. Any suitable therapeutic treatment for a particular cancer may be administered. Examples of chemotherapeutic and biotherapeutic agents include, but are not limited to, aldesleukin, altretamine, amifostine, asparaginase, bleomycin, capecitabine, carboplatin, carmustine, cladribine, cisapride, cisplatin, cyclophosphamide, cytarabine, dacarbazine (DTIC), dactinomycin, docetaxel, doxorubicin, dronabinol, epoetin alpha, etoposide, filgrastim, fludarabine, fluorouracil, gemcitabine, granisetron, hydroxyurea, idarubicin, ifosfamide, interferon alpha, irinotecan, lansoprazole, levamisole, leucovorin, megestrol, mesna, methotrexate, metoclopramide, mitomycin, mitotane, mitoxantrone, omeprazole, ondansetron, paclitaxel (Taxol®), pilocarpine, prochloroperazine, rituximab, tamoxifen, taxol, topotecan hydrochloride, trastuzumab, vinblastine, vincristine and vinorelbine tartrate. For prostate cancer treatment, a preferred chemotherapeutic agent with which anti-CTLA-4 can be combined is paclitaxel (Taxol®).

In addition, the subject may be further administered an anti-immunosuppressive or immunostimulatory agent. For example, the subject is further administered an anti-CTLA antibody or anti-PD-1 or anti-PD-L1. Blockade of CTLA-4 or PD-1/PD-L1 by antibodies can enhance the immune response to cancerous cells in the patient. In particular, CTLA-4 blockade has been shown effective when following a vaccination protocol (Hodi et al 2005).

The optimum amount of each peptide to be included in the vaccine composition and the optimum dosing regimen can be determined by one skilled in the art without undue experimentation. For example, the peptide or its variant may be prepared for intravenous (i.v.) injection, sub-cutaneous (s.c.) injection, intradermal (i.d.) injection, intraperitoneal (i.p.) injection, intramuscular (i.m.) injection. Preferred methods of peptide injection include s.c, i.d., i.p., i.m., and i.v. Preferred methods of DNA injection include i.d., i.m., s.c, i.p. and i.v. For example, doses of between 1 and 500 mg 50 µg and 1.5 mg, preferably 10 µg to 500 µg, of peptide or DNA may be given and will depend from the respective peptide or DNA. Doses of this range were successfully used in previous trials (Brunsvig P F, et al., Cancer Immunol  
25  
30 Immunother. 2006; 55(12): 1553- 1564; M. Staehler, et al., ASCO meeting 2007; Abstract No

2019203664  
24 May 2019

3017). Other methods of administration of the vaccine composition are known to those skilled in the art.

The inventive pharmaceutical composition may be compiled so that the selection, number and/or amount of peptides present in the composition is/are tissue, cancer, and/or patient-specific. For instance, the exact selection of peptides can be guided by expression patterns of the parent proteins in a given tissue to avoid side effects. The selection may be dependent on the specific type of cancer, the status of the disease, earlier treatment regimens, the immune status of the patient, and, of course, the HLA-haplotype of the patient. Furthermore, the vaccine according to the invention can contain individualized components, according to personal needs of the particular patient. Examples include varying the amounts of peptides according to the expression of the related neoantigen in the particular patient, unwanted side-effects due to personal allergies or other treatments, and adjustments for secondary treatments following a first round or scheme of treatment.

Pharmaceutical compositions comprising the peptide of the invention may be administered to an individual already suffering from cancer. In therapeutic applications, compositions are administered to a patient in an amount sufficient to elicit an effective CTL response to the tumor antigen and to cure or at least partially arrest symptoms and/or complications. An amount adequate to accomplish this is defined as “therapeutically effective dose.” Amounts effective for this use will depend on, e.g., the peptide composition, the manner of administration, the stage and severity of the disease being treated, the weight and general state of health of the patient, and the judgment of the prescribing physician, but generally range for the initial immunization (that is for therapeutic or prophylactic administration) from about 1.0  $\mu\text{g}$  to about 50,000  $\mu\text{g}$  of peptide for a 70 kg patient, followed by boosting dosages or from about 1.0  $\mu\text{g}$  to about 10,000  $\mu\text{g}$  of peptide pursuant to a boosting regimen over weeks to months depending upon the patient's response and condition and possibly by measuring specific CTL activity in the patient's blood. It should be kept in mind that the peptide and compositions of the present invention may generally be employed in serious disease states, that is, life-threatening or potentially life threatening situations, especially when the cancer has metastasized. For therapeutic use, administration should begin as soon as possible after the detection or surgical removal of tumors. This is followed by boosting doses until at least symptoms are substantially abated and for a period thereafter.

2019203664 24 May 2019

The pharmaceutical compositions (e.g., vaccine compositions) for therapeutic treatment are intended for parenteral, topical, nasal, oral or local administration. Preferably, the pharmaceutical compositions are administered parenterally, e.g., intravenously, subcutaneously, intradermally, or intramuscularly. The compositions may be administered at the site of surgical excision to induce a local immune response to the tumor. The invention provides compositions for parenteral administration which comprise a solution of the peptides and vaccine compositions are dissolved or suspended in an acceptable carrier, preferably an aqueous carrier. A variety of aqueous carriers may be used, e.g., water, buffered water, 0.9% saline, 0.3% glycine, hyaluronic acid and the like. These compositions may be sterilized by conventional, well known sterilization techniques, or may be sterile filtered. The resulting aqueous solutions may be packaged for use as is, or lyophilized, the lyophilized preparation being combined with a sterile solution prior to administration. The compositions may contain pharmaceutically acceptable auxiliary substances as required to approximate physiological conditions, such as pH adjusting and buffering agents, tonicity adjusting agents, wetting agents and the like, for example, sodium acetate, sodium lactate, sodium chloride, potassium chloride, calcium chloride, sorbitan monolaurate, triethanolamine oleate, etc.

The concentration of peptides of the invention in the pharmaceutical formulations can vary widely, i.e., from usually less than about 0.1%, to at least about 2% to as much as 20% to 50% or more by weight, and will be selected primarily by fluid volumes, viscosities, etc., in accordance with the particular mode of administration selected.

A liposome suspension containing a peptide may be administered intravenously, locally, topically, etc. in a dose which varies according to, inter alia, the manner of administration, the peptide being delivered, and the stage of the disease being treated. For targeting to the immune cells, a ligand, such as, e.g., antibodies or fragments thereof specific for cell surface determinants of the desired immune system cells, can be incorporated into the liposome. .

For solid compositions, conventional or nanoparticle nontoxic solid carriers may be used which include, for example, pharmaceutical grades of mannitol, lactose, starch, magnesium stearate, sodium saccharin, talcum, cellulose, glucose, sucrose, magnesium carbonate, and the like. For oral administration, a pharmaceutically acceptable nontoxic composition is formed by incorporating any of the normally employed excipients, such as those carriers previously listed,



2019203664 24 May 2019

and generally 10-95% of active ingredient, that is, one or more peptides of the invention, and more preferably at a concentration of 25%-75%.

For aerosol administration, the immunogenic peptides are preferably supplied in finely divided form along with a surfactant and propellant. Typical percentages of peptides are 0.01 %-20% by weight, preferably 1%-10%. The surfactant will, of course, be nontoxic, and preferably soluble in the propellant. Representative of such agents are the esters or partial esters of fatty acids containing from 6 to 22 carbon atoms, such as caproic, octanoic, lauric, palmitic, stearic, linoleic, linolenic, olesteric and oleic acids with an aliphatic polyhydric alcohol or its cyclic anhydride. Mixed esters, such as mixed or natural glycerides may be employed. The surfactant may constitute 0.1%-20% by weight of the composition, preferably 0.25-5%. The balance of the composition is ordinarily propellant. A carrier can also be included as desired, as with, e.g., lecithin for intranasal delivery.

The peptides and polypeptides of the invention can be readily synthesized chemically utilizing reagents that are free of contaminating bacterial or animal substances (Merrifield RB: Solid phase peptide synthesis. I. The synthesis of a tetrapeptide. J. Am. Chem. Soc. 85:2149-54, 1963).

For therapeutic or immunization purposes, nucleic acids encoding the peptide of the invention and optionally one or more of the peptides described herein can also be administered to the patient. A number of methods are conveniently used to deliver the nucleic acids to the patient. For instance, the nucleic acid can be delivered directly, as "naked DNA". This approach is described, for instance, in Wolff et al., Science 247: 1465-1468 (1990) as well as U.S. Patent Nos. 5,580,859 and 5,589,466. The nucleic acids can also be administered using ballistic delivery as described, for instance, in U.S. Patent No. 5,204,253. Particles comprised solely of DNA can be administered. Alternatively, DNA can be adhered to particles, such as gold particles.

The nucleic acids can also be delivered complexed to cationic compounds, such as cationic lipids. Lipid-mediated gene delivery methods are described, for instance, in WO1996/18372; WO 1993/24640; Mannino & Gould-Fogerite, BioTechniques 6(7): 682-691 (1988); U.S. Patent No. 5,279,833; WO 1991/06309; and Feigner et al., Proc. Natl. Acad. Sci. USA 84: 7413-7414 (1987).

2019203664 24 May 2019

RNA encoding the peptide of interest can also be used for delivery (see, e.g., Kiken et al, 2011; Su et al , 2011).

The peptides and polypeptides of the invention can also be expressed by attenuated viral hosts, such as vaccinia or fowlpox. This approach involves the use of vaccinia virus as a vector to express nucleotide sequences that encode the peptide of the invention. Upon introduction into an acutely or chronically infected host or into a noninfected host, the recombinant vaccinia virus expresses the immunogenic peptide, and thereby elicits a host CTL response. Vaccinia vectors and methods useful in immunization protocols are described in, e.g., U.S. Patent No. 4,722,848,. Another vector is BCG (Bacille Calmette Guerin). BCG vectors are described in Stover et al. (Nature 351:456-460 (1991)). A wide variety of other vectors useful for therapeutic administration or immunization of the peptides of the invention, e.g., Salmonella typhi vectors and the like, will be apparent to those skilled in the art from the description herein.

A preferred means of administering nucleic acids encoding the peptide of the invention uses minigene constructs encoding multiple epitopes. To create a DNA sequence encoding the selected CTL epitopes (minigene) for expression in human cells, the amino acid sequences of the epitopes are reverse translated. A human codon usage table is used to guide the codon choice for each amino acid. These epitope-encoding DNA sequences are directly adjoined, creating a continuous polypeptide sequence. To optimize expression and/or immunogenicity, additional elements can be incorporated into the minigene design. Examples of amino acid sequence that could be reverse translated and included in the minigene sequence include: helper T lymphocyte, epitopes, a leader (signal) sequence, and an endoplasmic reticulum retention signal. In addition, MHC presentation of CTL epitopes may be improved by including synthetic (e.g. poly-alanine) or naturally- occurring flanking sequences adjacent to the CTL epitopes.

25 The minigene sequence is converted to DNA by assembling oligonucleotides that encode the plus and minus strands of the minigene. Overlapping oligonucleotides (30-100 bases long) are synthesized, phosphorylated, purified and annealed under appropriate conditions using well known techniques. The ends of the oligonucleotides are joined using T4 DNA ligase. This synthetic minigene, encoding the CTL epitope polypeptide, can then cloned into a desired expression vector.

30 Standard regulatory sequences well known to those of skill in the art are included in the vector to ensure expression in the target cells. Several vector elements are required: a promoter

24 May 2019

2019203664

with a down-stream cloning site for minigene insertion; a polyadenylation signal for efficient transcription termination; an *E. coli* origin of replication; and an *E. coli* selectable marker (e.g. ampicillin or kanamycin resistance). Numerous promoters can be used for this purpose, e.g., the human cytomegalovirus (hCMV) promoter. See, U.S. Patent Nos. 5,580,859 and 5,589,466 for other suitable promoter sequences.

Additional vector modifications may be desired to optimize minigene expression and immunogenicity. In some cases, introns are required for efficient gene expression, and one or more synthetic or naturally-occurring introns could be incorporated into the transcribed region of the minigene. The inclusion of mRNA stabilization sequences can also be considered for increasing minigene expression. It has recently been proposed that immuno stimulatory sequences (ISSs or CpGs) play a role in the immunogenicity of DNA' vaccines. These sequences could be included in the vector, outside the minigene coding sequence, if found to enhance immunogenicity.

In some embodiments, a bicistronic expression vector, to allow production of the minigene-encoded epitopes and a second protein included to enhance or decrease immunogenicity can be used. Examples of proteins or polypeptides that could beneficially enhance the immune response if co-expressed include cytokines (e.g., IL2, IL12, GM-CSF), cytokine-inducing molecules (e.g. LeIF) or costimulatory molecules. Helper (HTL) epitopes could be joined to intracellular targeting signals and expressed separately from the CTL epitopes. This would allow direction of the HTL epitopes to a cell compartment different than the CTL epitopes. If required, this could facilitate more efficient entry of HTL epitopes into the MHC class II pathway, thereby improving CTL induction. In contrast to CTL induction, specifically decreasing the immune response by co-expression of immunosuppressive molecules (e.g. TGF- $\beta$ ) may be beneficial in certain diseases.

25        Once an expression vector is selected, the minigene is cloned into the polylinker region downstream of the promoter. This plasmid is transformed into an appropriate *E. coli* strain, and DNA is prepared using standard techniques. The orientation and DNA sequence of the minigene, as well as all other elements included in the vector, are confirmed using restriction mapping and DNA sequence analysis. Bacterial cells harboring the correct plasmid can be  
30        stored as a master cell bank and a working cell bank.

2019203664  
24 May 2019

Purified plasmid DNA can be prepared for injection using a variety of formulations. The simplest of these is reconstitution of lyophilized DNA in sterile phosphate-buffer saline (PBS). A variety of methods have been described, and new techniques may become available. As noted above, nucleic acids are conveniently formulated with cationic lipids. In addition, glycolipids, fusogenic liposomes, peptides and compounds referred to collectively as protective, interactive, non-condensing (PINC) could also be complexed to purified plasmid DNA to influence variables such as stability, intramuscular dispersion, or trafficking to specific organs or cell types.

Target cell sensitization can be used as a functional assay for expression and MHC class I presentation of minigene-encoded CTL epitopes. The plasmid DNA is introduced into a mammalian cell line that is suitable as a target for standard CTL chromium release assays. The transfection method used will be dependent on the final formulation. Electroporation can be used for "naked" DNA, whereas cationic lipids allow direct in vitro transfection. A plasmid expressing green fluorescent protein (GFP) can be co-transfected to allow enrichment of transfected cells using fluorescence activated cell sorting (FACS). These cells are then chromium-51 labeled and used as target cells for epitope-specific CTL lines. Cytolysis, detected by 51 Cr release, indicates production of MHC presentation of mini gene-encoded CTL epitopes.

In vivo immunogenicity is a second approach for functional testing of minigene DNA formulations. Transgenic mice expressing appropriate human MHC molecules are immunized with the DNA product. The dose and route of administration are formulation dependent (e.g. IM for DNA in PBS, IP for lipid-complexed DNA). Twenty-one days after immunization, splenocytes are harvested and restimulated for 1 week in the presence of peptides encoding each epitope being tested. These effector cells (CTLs) are assayed for cytolysis of peptide-loaded, chromium-51 labeled target cells using standard techniques. Lysis of target cells sensitized by MHC loading of peptides corresponding to minigene-encoded epitopes demonstrates DNA vaccine function for in vivo induction of CTLs.

Peptides may be used to elicit CTL ex vivo, as well. The resulting CTL, can be used to treat chronic tumors in patients that do not respond to other conventional forms of therapy, or will not respond to a peptide vaccine approach of therapy. Ex vivo CTL responses to a particular tumor antigen are induced by incubating in tissue culture the patient's CTL precursor cells (CTLp) together with a source of antigen-presenting cells (APC) and the appropriate peptide. After an appropriate incubation time (typically 1-4 weeks), in which the CTLp are activated and

24 May 2019

2019203664

mature and expand into effector CTL, the cells are infused back into the patient, where they will destroy their specific target cell (i.e., a tumor cell). In order to optimize the in vitro conditions for the generation of specific cytotoxic T cells, the culture of stimulator cells is maintained in an appropriate serum-free medium.

Prior to incubation of the stimulator cells with the cells to be activated, e.g., precursor CD8+ cells, an amount of antigenic peptide is added to the stimulator cell culture, of sufficient quantity to become loaded onto the human Class I molecules to be expressed on the surface of the stimulator cells. In the present invention, a sufficient amount of peptide is an amount that will allow about 200, and preferably 200 or more, human Class I MHC molecules loaded with peptide to be expressed on the surface of each stimulator cell. Preferably, the stimulator cells are incubated with >2 $\mu$ g/ml peptide. For example, the stimulator cells are incubated with > 3, 4, 5, 10, 15, or more  $\mu$ g/ml peptide.

Resting or precursor CD8+ cells are then incubated in culture with the appropriate stimulator cells for a time period sufficient to activate the CD8+ cells. Preferably, the CD8+ cells are activated in an antigen-specific manner. The ratio of resting or precursor CD8+ (effector) cells to stimulator cells may vary from individual to individual and may further depend upon variables such as the amenability of an individual's lymphocytes to culturing conditions and the nature and severity of the disease condition or other condition for which the within-described treatment modality is used. Preferably, however, the lymphocyte: stimulator cell ratio is in the range of about 30: 1 to 300: 1. The effector/stimulator culture may be maintained for as long a time as is necessary to stimulate a therapeutically useable or effective number of CD8+ cells.

The induction of CTL in vitro requires the specific recognition of peptides that are bound to allele specific MHC class I molecules on APC. The number of specific MHC/peptide complexes per APC is crucial for the stimulation of CTL, particularly in primary immune responses. While small amounts of peptide/MHC complexes per cell are sufficient to render a cell susceptible to lysis by CTL, or to stimulate a secondary CTL response, the successful activation of a CTL precursor (pCTL) during primary response requires a significantly higher number of MHC/peptide complexes. Peptide loading of empty major histocompatibility complex molecules on cells allows the induction of primary cytotoxic T lymphocyte responses.

Since mutant cell lines do not exist for every human MHC allele, it is advantageous to use a technique to remove endogenous MHC-associated peptides from the surface of APC,

2019203664 24 May 2019

followed by loading the resulting empty MHC molecules with the immunogenic peptides of interest. The use of non-transformed (non-tumorigenic), noninfected cells, and preferably, autologous cells of patients as APC is desirable for the design of CTL induction protocols directed towards development of ex vivo CTL therapies. This application discloses methods for stripping the endogenous MHC-associated peptides from the surface of APC followed by the loading of desired peptides.

A stable MHC class I molecule is a trimeric complex formed of the following elements: 1) a peptide usually of 8 - 10 residues, 2) a transmembrane heavy polymorphic protein chain which bears the peptide-binding site in its  $\alpha 1$  and  $\alpha 2$  domains, and 3) a non-covalently associated non-polymorphic light chain,  $\beta 2$ microglobulin. Removing the bound peptides and/or dissociating the  $\beta 2$ microglobulin from the complex renders the MHC class I molecules nonfunctional and unstable, resulting in rapid degradation. All MHC class I molecules isolated from PBMCs have endogenous peptides bound to them. Therefore, the first step is to remove all endogenous peptides bound to MHC class I molecules on the APC without causing their degradation before exogenous peptides can be added to them.

Two possible ways to free up MHC class I molecules of bound peptides include lowering the culture temperature from 37°C to 26°C overnight to destabilize  $\beta 2$ microglobulin and stripping the endogenous peptides from the cell using a mild acid treatment. The methods release previously bound peptides into the extracellular environment allowing new exogenous peptides to bind to the empty class I molecules. The cold-temperature incubation method enables exogenous peptides to bind efficiently to the MHC complex, but requires an overnight incubation at 26°C which may slow the cell's metabolic rate. It is also likely that cells not actively synthesizing MHC molecules (e.g., resting PBMC) would not produce high amounts of empty surface MHC molecules by the cold temperature procedure.

25 Harsh acid stripping involves extraction of the peptides with trifluoroacetic acid, pH 2, or acid denaturation of the immunoaffinity purified class I-peptide complexes. These methods are not feasible for CTL induction, since it is important to remove the endogenous peptides while preserving APC viability and an optimal metabolic state which is critical for antigen presentation. Mild acid solutions of pH 3 such as glycine or citrate -phosphate buffers have been  
30 used to identify endogenous peptides and to identify tumor associated T cell epitopes. The treatment is especially effective, in that only the MHC class I molecules are destabilized (and

2019203664 24 May 2019

associated peptides released), while other surface antigens remain intact, including MHC class II molecules. Most importantly, treatment of cells with the mild acid solutions do not affect the cell's viability or metabolic state. The mild acid treatment is rapid since the stripping of the endogenous peptides occurs in two minutes at 4°C and the APC is ready to perform its function after the appropriate peptides are loaded. The technique is utilized herein to make peptide-specific APCs for the generation of primary antigen-specific CTL. The resulting APC are efficient in inducing peptide-specific CD8+ CTL.

Activated CD8+ cells may be effectively separated from the stimulator cells using one of a variety of known methods. For example, monoclonal antibodies specific for the stimulator cells, for the peptides loaded onto the stimulator cells, or for the CD8+ cells (or a segment thereof) may be utilized to bind their appropriate complementary ligand. Antibody-tagged molecules may then be extracted from the stimulator-effector cell admixture via appropriate means, e.g., via well-known immunoprecipitation or immunoassay methods.

Effective, cytotoxic amounts of the activated CD8+ cells can vary between in vitro and in vivo uses, as well as with the amount and type of cells that are the ultimate target of these killer cells. The amount will also vary depending on the condition of the patient and should be determined via consideration of all appropriate factors by the practitioner. Preferably, however, about  $1 \times 10^6$  to about  $1 \times 10^{12}$ , more preferably about  $1 \times 10^8$  to about  $1 \times 10^{11}$ , and even more preferably, about  $1 \times 10^9$  to about  $1 \times 10^{10}$  activated CD8+ cells are utilized for adult humans, compared to about  $5 \times 10^6$  -  $5 \times 10^7$  cells used in mice.

Preferably, as discussed above, the activated CD8+ cells are harvested from the cell culture prior to administration of the CD8+ cells to the individual being treated. It is important to note, however, that unlike other present and proposed treatment modalities, the present method uses a cell culture system that is not tumorigenic. Therefore, if complete separation of stimulator cells and activated CD8+ cells is not achieved, there is no inherent danger known to be associated with the administration of a small number of stimulator cells, whereas administration of mammalian tumor-promoting cells may be extremely hazardous.

Methods of re-introducing cellular components are known in the art and include procedures such as those exemplified in U.S. Patent No. 4,844,893 to Honsik, et al. and U.S. Patent No. 4,690,915 to Rosenberg. For example, administration of activated CD8+ cells via intravenous infusion is appropriate.

2019203664  
24 May 2019

CD8+ cell activity may be augmented through the use of CD4+ cells. The identification of CD4 T+ cell epitopes for tumor antigens has attracted interest because many immune based therapies against cancer may be more effective if both CD8+ and CD4+ T lymphocytes are used to target a patient's tumor. CD4+ cells are capable of enhancing CD8 T cell responses. Many studies in animal models have clearly demonstrated better results when both CD4+ and CD8+ T cells participate in anti-tumor responses (see e.g., Nishimura et al. (1999) Distinct role of antigen-specific T helper type 1 (TH1) and Th2 cells in tumor eradication in vivo. *J Ex Med* 190:617-27). Universal CD4+ T cell epitopes have been identified that are applicable to developing therapies against different types of cancer (see e.g., Kobayashi et al. (2008) *Current Opinion in Immunology* 20:221-27). For example, an HLA-DR restricted helper peptide from tetanus toxoid was used in melanoma vaccines to activate CD4+ T cells non-specifically (see e.g., Slingluff et al. (2007) *Immunologic and Clinical Outcomes of a Randomized Phase II Trial of Two Muropeptide Vaccines for Melanoma in the Adjuvant Setting*, *Clinical Cancer Research* 13(21):6386-95). It is contemplated within the scope of the invention that such CD4+ cells may be applicable at three levels that vary in their tumor specificity: 1) a broad level in which universal CD4+ epitopes (e.g., tetanus toxoid) may be used to augment CD8+ cells; 2) an intermediate level in which native, tumor-associated CD4+ epitopes may be used to augment CD8+ cells; and 3) a patient specific level in which neoantigen CD4+ epitopes may be used to augment CD8+ cells in a patient specific manner.

CD8+ cell immunity may also be generated with neo-antigen loaded dendritic cell (DC) vaccine. DCs are potent antigen-presenting cells that initiate T cell immunity and can be used as cancer vaccines when loaded with one or more peptides of interest, for example, by direct peptide injection. For example, patients that were newly diagnosed with metastatic melanoma were shown to be immunized against 3 HLA-A\*0201-restricted gp100 melanoma antigen-derived peptides with autologous peptide pulsed CD40L/IFN-g-activated mature DCs via an IL-12p70-producing patient DC vaccine (see e.g., Carreno et al (2013) L-12p70-producing patient DC vaccine elicits Tc1-polarized immunity, *Journal of Clinical Investigation*, 123(8):3383-94 and Ali et al. (2009) *In situ regulation of DC subsets and T cells mediates tumor regression in mice*, *Cancer Immunotherapy*, 1(8):1-10). It is contemplated within the scope of the invention that neo-antigen loaded DCs may be prepared using the synthetic TLR 3 agonist Polyinosinic-Polycytidylic Acid-poly-L-lysine Carboxymethylcellulose (Poly-ICLC) to stimulate the DCs.



2019203664  
24 May 2019

Poly-ICLC is a potent individual maturation stimulus for human DCs as assessed by an upregulation of CD83 and CD86, induction of interleukin-12 (IL-12), tumor necrosis factor (TNF), interferon gamma-induced protein 10 (IP-10), interleukin 1 (IL-1), and type I interferons (IFN), and minimal interleukin 10 (IL-10) production. DCs may be differentiated from frozen peripheral blood mononuclear cells (PBMCs) obtained by leukapheresis, while PBMCs may be isolated by Ficoll gradient centrifugation and frozen in aliquots.

Illustratively, the following 7 day activation protocol may be used. Day 1—PBMCs are thawed and plated onto tissue culture flasks to select for monocytes which adhere to the plastic surface after 1-2 hr incubation at 37°C in the tissue culture incubator. After incubation, the lymphocytes are washed off and the adherent monocytes are cultured for 5 days in the presence of interleukin-4 (IL-4) and granulocyte macrophage-colony stimulating factor (GM-CSF) to differentiate to immature DCs. On Day 6, immature DCs are pulsed with the keyhole limpet hemocyanin (KLH) protein which serves as a control for the quality of the vaccine and may boost the immunogenicity of the vaccine. The DCs are stimulated to mature, loaded with peptide antigens, and incubated overnight. On Day 7, the cells are washed, and frozen in 1 ml aliquots containing  $4\text{-}20 \times 10^6$  cells using a controlled-rate freezer. Lot release testing for the batches of DCs may be performed to meet minimum specifications before the DCs are injected into patients (see e.g., Sabado et al. (2013) Preparation of tumor antigen-loaded mature dendritic cells for immunotherapy, *J. Vis Exp.* Aug 1;(78). doi: 10.3791/50085).

A DC vaccine may be incorporated into a scaffold system to facilitate delivery to a patient. Therapeutic treatment of a patient's neoplasia with a DC vaccine may utilize a biomaterial system that releases factors that recruit host dendritic cells into the device, differentiates the resident, immature DCs by locally presenting adjuvants (e.g., danger signals) while releasing antigen, and promotes the release of activated, antigen loaded DCs to the lymph nodes (or desired site of action) where the DCs may interact with T cells to generate a potent cytotoxic T lymphocyte response to the cancer neo-antigens. Implantable biomaterials may be used to generate a potent cytotoxic T lymphocyte response against a neoplasia in a patient specific manner. The biomaterial-resident dendritic cells may then be activated by exposing them to danger signals mimicking infection, in concert with release of antigen from the biomaterial. The activated dendritic cells then migrate from the biomaterials to lymph nodes to induce a cytotoxic T effector response. This approach has previously been demonstrated to lead

2019203664 24 May 2019

to regression of established melanoma in preclinical studies using a lysate prepared from tumor biopsies (see e.g., Ali et al. (2009) In situ regulation of DC subsets and T cells mediates tumor regression in mice, *Cancer Immunotherapy* 1(8):1-10; Ali et al. (2009) Infection-mimicking materials to program dendritic cells in situ. *Nat Mater* 8:151-8), and such a vaccine is currently being tested in a Phase I clinical trial recently initiated at the Dana-Farber Cancer Institute. This approach has also been shown to lead to regression of glioblastoma, as well as the induction of a potent memory response to prevent relapse, using the C6 rat glioma model.<sup>24</sup> In the current proposal. The ability of such an implantable, biomatrix vaccine delivery scaffold to amplify and sustain tumor specific dendritic cell activation may lead to more robust anti-tumor immunosensitization than can be achieved by traditional subcutaneous or intra-nodal vaccine administrations.

The practice of the present invention employs, unless otherwise indicated, conventional techniques of molecular biology (including recombinant techniques), microbiology, cell biology, biochemistry and immunology, which are well within the purview of the skilled artisan. Such techniques are explained fully in the literature, such as, “Molecular Cloning: A Laboratory Manual”, second edition (Sambrook, 1989); “Oligonucleotide Synthesis” (Gait, 1984); “Animal Cell Culture” (Freshney, 1987); “Methods in Enzymology” “Handbook of Experimental Immunology” (Wei, 1996); “Gene Transfer Vectors for Mammalian Cells” (Miller and Calos, 1987); “Current Protocols in Molecular Biology” (Ausubel, 1987); “PCR: The Polymerase Chain Reaction”, (Mullis, 1994); “Current Protocols in Immunology” (Coligan, 1991). These techniques are applicable to the production of the polynucleotides and polypeptides of the invention, and, as such, may be considered in making and practicing the invention. Particularly useful techniques for particular embodiments will be discussed in the sections that follow.

25

## EXAMPLES

The following examples are put forth so as to provide those of ordinary skill in the art with a complete disclosure and description of how to make and use the assay, screening, and therapeutic methods of the invention, and are not intended to limit the scope of what the inventors regard as their invention.

30

2019203664 24 May 2019

**Example 1: Cancer Vaccine Testing Protocol**

The above-described compositions and methods may be tested on 15 patients with high-risk melanoma (fully resected stages IIIB, IIIC and IVM1a,b) according to the general flow process shown in FIG. 2. Patients may receive a series of priming vaccinations with a mixture of personalized tumor-specific peptides and poly-ICLC over a 4 week period followed by two boosts during a maintenance phase. All vaccinations will be subcutaneously delivered. The vaccine will be evaluated for safety, tolerability, immune response and clinical effect in patients and for feasibility of producing vaccine and successfully initiating vaccination within an appropriate time frame. The first cohort will consist of 5 patients, and after safety is adequately demonstrated, an additional cohort of 10 patients may be enrolled (see, e.g., FIG. 3 depicting an approach for an initial population study). Peripheral blood will be extensively monitored for peptide-specific T-cell responses and patients will be followed for up to two years to assess disease recurrence.

As described above, there is a large body of evidence in both animals and humans that mutated epitopes are effective in inducing an immune response and that cases of spontaneous tumor regression or long term survival correlate with CD8<sup>+</sup> T-cell responses to mutated epitopes (Buckwalter and Srivastava PK. "It is the antigen(s), stupid" and other lessons from over a decade of vaccitherapy of human cancer. *Seminars in immunology* 20:296-300 (2008); Karanikas et al, High frequency of cytolytic T lymphocytes directed against a tumor-specific mutated antigen detectable with HLA tetramers in the blood of a lung carcinoma patient with long survival. *Cancer Res.* 61:3718-3724 (2001); Lennerz et al, The response of autologous T cells to a human melanoma is dominated by mutated neo-antigens. *Proc Natl Acad Sci U S A.* 102:16013 (2005)) and that "immunoediting" can be tracked to alterations in expression of dominant mutated antigens in mice and man (Matsushita et al, Cancer exome analysis reveals a T-cell-dependent mechanism of cancer immunoediting *Nature* 482:400 (2012); DuPage et al, Expression of tumor-specific antigens underlies cancer immunoediting *Nature* 482:405 (2012); and Sampson et al, Immunologic escape after prolonged progression-free survival with epidermal growth factor receptor variant III peptide vaccination in patients with newly diagnosed glioblastoma *J Clin Oncol.* 28:4722-4729 (2010)).

Next-generation sequencing can now rapidly reveal the presence of discrete mutations such as coding mutations in individual tumors, most commonly single amino acid changes (e.g.,

2019203664 24 May 2019

missense mutations; FIG. 4A) and less frequently novel stretches of amino acids generated by frame-shift insertions/deletions/gene fusions, read-through mutations in stop codons, and translation of improperly spliced introns (e.g., neoORFs; FIG. 4B). NeoORFs are particularly valuable as immunogens because the entirety of their sequence is completely novel to the immune system and so are analogous to a viral or bacterial foreign antigen. Thus, neoORFs: (1) are highly specific to the tumor (i.e. there is no expression in any normal cells); (2) can bypass central tolerance, thereby increasing the precursor frequency of neoantigen-specific CTLs. For example, the power of utilizing analogous foreign sequences in a therapeutic anti-cancer vaccine was recently demonstrated with peptides derived from human papilloma virus (HPV). ~50% of the 19 patients with pre-neoplastic, viral-induced disease who received 3 - 4 vaccinations of a mix of HPV peptides derived from the viral oncogenes E6 and E7 maintained a complete response for  $\geq 24$  months ( Kenter et a, Vaccination against HPV-16 Oncoproteins for Vulvar Intraepithelial Neoplasia NEJM 361:1838 (2009)).

Sequencing technology has revealed that each tumor contains multiple, patient-specific mutations that alter the protein coding content of a gene. Such mutations create altered proteins, ranging from single amino acid changes (caused by missense mutations) to addition of long regions of novel amino acid sequence due to frame shifts, read-through of termination codons or translation of intron regions (novel open reading frame mutations; neoORFs). These mutated proteins are valuable targets for the host's immune response to the tumor as, unlike native proteins, they are not subject to the immune-dampening effects of self-tolerance. Therefore, mutated proteins are more likely to be immunogenic and are also more specific for the tumor cells compared to normal cells of the patient.

Utilizing recently improved algorithms for predicting which missense mutations create strong binding peptides to the patient's cognate MHC molecules, a set of peptides representative of optimal mutated epitopes (both neoORF and missense) for each patient will be identified and prioritized and up to 20 or more peptides will be prepared for immunization (Zhang et al, Machine learning competition in immunology – Prediction of HLA class I binding peptides J Immunol Methods 374:1 (2011); Lundegaard et al Prediction of epitopes using neural network based methods J Immunol Methods 374:26 (2011)). Peptides ~20-35 amino acids in length will be synthesized because such "long" peptides undergo efficient internalization, processing and cross-presentation in professional antigen-presenting cells such as dendritic cells, and have been

2019203664  
24 May 2019

shown to induce CTLs in humans (Melief and van der Burg, Immunotherapy of established (pre) malignant disease by synthetic long peptide vaccines *Nature Rev Cancer* 8:351 (2008)).

In addition to a powerful and specific immunogen, an effective immune response requires a strong adjuvant to activate the immune system (Speiser and Romero, Molecularly defined vaccines for cancer immunotherapy, and protective T cell immunity *Seminars in Immunol* 22:144 (2010)). For example, Toll-like receptors (TLRs) have emerged as powerful sensors of microbial and viral pathogen “danger signals”, effectively inducing the innate immune system, and in turn, the adaptive immune system (Bhardwaj and Gnjatic, TLR AGONISTS: Are They Good Adjuvants? *Cancer J.* 16:382-391 (2010)). Among the TLR agonists, poly-ICLC (a synthetic double-stranded RNA mimic) is one of the most potent activators of myeloid-derived dendritic cells. In a human volunteer study, poly-ICLC has been shown to be safe and to induce a gene expression profile in peripheral blood cells comparable to that induced by one of the most potent live attenuated viral vaccines, the yellow fever vaccine YF-17D (Caskey et al, Synthetic double-stranded RNA induces innate immune responses similar to a live viral vaccine in humans *J Exp Med* 208:2357 (2011)). Hiltonol®, a GMP preparation of poly-ICLC prepared by Oncovir, Inc, will be utilized as the adjuvant.

### Example 2: Target Patient Population

Patients with stage IIIB, IIIC and IVM1a,b, melanoma have a significant risk of disease recurrence and death, even with complete surgical resection of disease (Balch et al, Final Version of 2009 AJCC Melanoma Staging and Classification *J Clin Oncol* 27:6199 – 6206 (2009)). An available systemic adjuvant therapy for this patient population is interferon- $\alpha$  (IFN $\alpha$ ) which provides a measurable but marginal benefit and is associated with significant, frequently dose-limiting toxicity (Kirkwood et al, Interferon alfa-2b Adjuvant Therapy of High-Risk Resected Cutaneous Melanoma: The Eastern Cooperative Oncology Group Trial EST 1684 *J Clin Oncol* 14:7-17 (1996); Kirkwood et al , High- and Low-dose Interferon Alpha-2b in High-Risk Melanoma: First Analysis of Intergroup Trial E1690/S9111/C9190 *J Clin Oncol* 18:2444 – 2458 (2000)). These patients are not immuno-compromised by previous cancer-directed therapy or by active cancer and thus represent an excellent patient population in which to assess the safety and immunological impact of the vaccine. Finally, current standard of care for these patients does

25

30

2019203664 24 May 2019

not mandate any treatment following surgery, thus allowing for the 8 – 10 week window for vaccine preparation.

The target population will be cutaneous melanoma patients with clinically detectable, histologically confirmed nodal (local or distant) or in transit metastasis, who have been fully resected and are free of disease (most of stage IIIB (because of the need to have adequate tumor tissue for sequencing and cell line development, patients with ulcerated primary tumor but micrometastatic lymph nodes (T1-4b, N1a or N2a) will be excluded.), all of stage IIIC, and stage IVM1a, b). These may be patients at first diagnosis or at disease recurrence after previous diagnosis of an earlier stage melanoma.

**Tumor harvest:** Patients will undergo complete resection of their primary melanoma (if not already removed) and all regional metastatic disease with the intent of rendering them free of melanoma. After adequate tumor for pathological assessment has been harvested, remaining tumor tissue will be placed in sterile media in a sterile container and prepared for disaggregation. Portions of the tumor tissue will be used for whole-exome and transcriptome sequencing and cell line generation and any remaining tumor will be frozen.

**Normal tissue harvest:** A normal tissue sample (blood or sputum sample ) will be taken for whole exome sequencing.

Patients with clinically evident locoregional metastatic disease or fully resectable distant nodal, cutaneous or lung metastatic disease (but absence of unresectable distant or visceral metastatic disease) will be identified and enrolled on the study. Entry of patients prior to surgery is necessary in order to acquire fresh tumor tissue for melanoma cell line development (to generate target cells for in vitro cytotoxicity assays as part of the immune monitoring plan).

### **Example 3: Dose and Schedule**

25 For patients who have met all pre-treatment criteria, vaccine administration will commence as soon as possible after the study drug has arrived and has met incoming specifications. For each patient, there will be four separate study drugs, each containing 5 of 20 patient-specific peptides. Immunizations may generally proceed according to the schedule shown in FIG. 5.

30 Patients will be treated in an outpatient clinic. Immunization on each treatment day will consist of four 1 ml subcutaneous injections, each into a separate extremity in order to target

2019203664 24 May 2019

different regions of the lymphatic system to reduce antigenic competition. If the patient has undergone complete axillary or inguinal lymph node dissection, vaccines will be administered into the right or left midriff as an alternative. Each injection will consist of 1 of the 4 study drugs for that patient and the same study drug will be injected into the same extremity for each cycle. The composition of each 1 ml injection is:

0.75 ml study drug containing 300 µg each of 5 patient-specific peptides

0.25 ml (0.5 mg) of 2 mg/ml poly-ICLC (Hiltonol®)

During the induction/priming phase, patients will be immunized on days 1, 4, 8, 15 and 22. In the maintenance phase, patients will receive booster doses at weeks 12 and 24.

Blood samples may be obtained at multiple time points: pre- (baseline; two samples on different days); day 15 during priming vaccination; four weeks after the induction/priming vaccination (week 8); pre- (week 12) and post- (week 16) first boost; pre- (week 24) and post- (week 28) second boost 50 – 150 ml blood will be collected for each sample (except week 16). The primary immunological endpoint will be at week 16, and hence patients will undergo leukapheresis (unless otherwise indicated based on patient and physician assessment).

#### **Example 4: Immune Monitoring**

The immunization strategy is a “prime-boost” approach, involving an initial series of closely spaced immunizations to induce an immune response followed by a period of rest to allow memory T-cells to be established. This will be followed by a booster immunization, and the T-cell response 4 weeks after this boost is expected to generate the strongest response and will be the primary immunological endpoint. Global immunological response will be initially monitored using peripheral blood mononuclear cells from this time point in an 18 hr *ex vivo* ELISPOT assay, stimulating with a pool of overlapping 15mer peptides (11 aa overlap)

25 comprising all the immunizing epitopes. Pre-vaccination samples will be evaluated to establish the baseline response to this peptide pool. As warranted, additional PBMC samples will be evaluated to examine the kinetics of the immune response to the total peptide mix. For patients demonstrating responses significantly above baseline, the pool of all 15mers will be de-convoluted to determine which particular immunizing peptide(s) were immunogenic. In  
30 addition, a number of additional assays will be conducted on a case-by-case basis for appropriate samples:

2019203664 24 May 2019

- The entire 15mer pool or sub-pools will be used as stimulating peptides for intracellular cytokine staining assays to identify and quantify antigen-specific CD4+, CD8+, central memory and effector memory populations
- Similarly, these pools will be used to evaluate the pattern of cytokines secreted by these cells to determine the T<sub>H</sub>1 vs T<sub>H</sub>2 phenotype
- Extracellular cytokine staining and flow cytometry of unstimulated cells will be used to quantify Treg and myeloid-derived suppressor cells (MDSC).
- If a melanoma cell line is successfully established from a responding patient and the activating epitope can be identified, T-cell cytotoxicity assays will be conducted using the mutant and corresponding wild type peptide
- PBMC from the primary immunological endpoint will be evaluated for “epitope spreading” by using known melanoma tumor associated antigens as stimulants and by using several additional identified mutated epitopes that were not selected to be among the immunogens, as shown in FIG. 6.

Immuno-histochemistry of the tumor sample will be conducted to quantify CD4+, CD8+, MDSC, and Treg infiltrating populations.

### **Example 5: Clinical Efficacy in Patients with Metastatic Disease**

Vaccine treatment of patients with metastatic disease is complicated by their need for an effective therapy for the active cancer and the consequent absence of an off treatment time window for vaccine preparation. Furthermore, these cancer treatments may compromise the patient’s immune system, possibly impeding the induction of an immune response. With these considerations in mind, settings may be chosen where timing of vaccine preparation fits temporally with other standard care approaches for the particular patient population and/or where such standard care is demonstrably compatible with an immunotherapeutic approach. There are two types of settings that may be pursued:

1. Combination with checkpoint blockade: Checkpoint blockade antibodies have emerged as an effective immunotherapy for metastatic melanoma (Hodi et al, Improved Survival with Ipilimumab in Patients with Metastatic Melanoma NEJM 363:711 – 723 (2010)) and are being actively pursued in other disease settings including non-small cell lung cancer (NSCLC) and renal cell carcinoma (Topalian et al, Safety, Activity, and Immune Correlates of Anti-PD-1



2019203664 24 May 2019

Antibody in Cancer NEJM 366:2443-2454 (2012); Brahmer et al, Safety and Activity of Anti-PD-L1 Antibody in Patients with Advanced Cancer NEJM 366:2455-2465(2012)). Although the mechanism of action is not proven, both reversal of relief from local immunosuppression and enhancement of an immune response are possible explanations. Integrating a powerful vaccine to initiate an immune response with checkpoint blockade antibodies may provide synergies, as observed in multiple animal studies (van Elsas et al Combination immunotherapy of B16 melanoma using anti-cytotoxic T lymphocyte-associated antigen 4 (CTLA-4) and granulocyte/macrophage colony-stimulating factor (GM-CSF)-producing vaccines induces rejection of subcutaneous and metastatic tumors accompanied by autoimmune depigmentation J Exp Med 190:35- 366 (1999); Li et al, Anti-programmed death-1 synergizes with granulocyte macrophage colony-stimulating factor –secreting tumor cell immunotherapy providing therapeutic benefit to mice with established tumors Clin Cancer Res 15:1623 – 1634 (2009); Pardoll, D. M. The blockade of immune checkpoints in cancer immunotherapy Nature Reviews Cancer 12:252 – 264 (2012); Curran et al. PD-1 and CTLA-4 combination blockade expands infiltrating T cells and reduces regulatory T and myeloid cells within B16 melanoma tumors. Proc Natl Acad Sci U S A. 2010 Mar 2;107(9):4275-80; Curran et al. Tumor vaccines expressing flt3 ligand synergize with ctla-4 blockade to reject preimplanted tumors. Cancer Res. 2009 Oct 1;69(19):7747-55). Patients can be immediately started on checkpoint blockade therapy while vaccine is being prepared and once prepared, the vaccine dosing can be integrated with antibody therapy, as illustrated in FIG. 7; and

2. Combination with standard treatment regimens exhibiting beneficial immune properties.

a) Renal cell carcinoma (RCC) patients who present with metastatic disease typically undergo surgical de-bulking followed by systemic treatment, which is commonly with one of the approved tyrosine kinase inhibitors (TKI) such as sunitinib, pazopanib and sorafenib. Of the approved TKIs, sunitinib has been shown to increase  $T_H1$  responsiveness and decrease Treg and myeloid-derived suppressor cells (Finke et al, Sunitinib reverses Type-1 immune suppression and decreases T-regulatory cells in renal cell carcinoma patients Clin Can Res 14:6674 - 6682 (2008); Terme et al, VEGFA-VEGFR pathway blockade inhibits tumor-induced regulatory T cell proliferation in colorectal cancer (Cancer Research Author Manuscript published Online (2102)). The ability to immediately treat patients with an approved therapy that does not

2019203664 24 May 2019

compromise the immune system provides the needed window to prepare the vaccine and could provide synergy with a vaccine therapy. In addition, cyclophosphamide (CTX) has been implicated in multiple animal and human studies to have an inhibitory effect on Treg cells and a single dose of CTX prior to a vaccine has been recently shown to improve survival in RCC patients who responded to the vaccine (Walter et al, Multi-peptide immune response to a cancer vaccine IMA901 after single-dose cyclophosphamide associates with longer patient survival *Nature Medicine* 18:1254- 1260 (2012)). Both of these immune-synergistic approaches have been utilized in a recently completed phase 3 study of a native peptide vaccine in RCC (ClinicalTrials.gov, NCT01265901 IMA901 in Patients Receiving Sunitinib for Advanced/Metastatic Renal Cell Carcinoma);

b) Alternatively, standard treatment of glioblastoma (GBM) involves surgery, recovery and follow-up radiation and low dose temozolomide (TMZ) followed by a four week rest period before initiating standard dose TMZ. This standard treatment provides a window for vaccine preparation followed by initiation of vaccination prior to starting standard dose TMZ. Interestingly, in a study in metastatic melanoma, peptide vaccination during standard dose TMZ treatment increased the measured immune responsiveness compared to vaccination alone, suggesting additional synergistic benefit (Kyte et al, Telomerase peptide vaccination combined with temozolomide: a clinical trial in stage IV melanoma patients *Clin Cancer Res* 17:4568 (2011)).

### **Example 6: Vaccine Preparation**

Patient tumor tissue will be surgically resected, and tumor tissue will be disaggregated and separate portions used for DNA and RNA extraction and for patient-specific melanoma cell line development. DNA and/or RNA extracted from the tumor tissue will be used for whole-exome sequencing (e.g., by using the Illumina HiSeq platform) and to determine HLA typing information. It is contemplated within the scope of the invention that missense or neoORF neo-antigenic peptides may be directly identified by protein-based techniques (e.g., mass spectrometry).

Bioinformatics analysis will be conducted as follows. Sequence analysis of the Exome and RNA – SEQ fast Q files will leverage existing bioinformatic pipelines that have been used and validated extensively in large-scale projects such as the TCGA for many patient samples

(e.g., Chapman et al, 2011, Stransky et al, 2011, Berger et al, 2012). There are two sequential categories of analyses: data processing and cancer genome analysis.

Data processing pipeline: The Picard data processing pipeline ([picard.sourceforge.net/](http://picard.sourceforge.net/)) was developed by the Sequencing Platform. Raw data extracted from (e.g., Illumina) sequencers for each tumor and normal sample is subjected to the following processes using various modules in the Picard pipeline:

- (i). Quality recalibration: Original base quality scores reported by the Illumina pipeline will be recalibrated based on the read-cycle, the lane, the flow cell tile, the base in question, and the preceding base.
- (ii). Alignment: BWA (Li and Durbin, 2009) will be used to align read pairs to the human genome (hg19).
- (iii). Mark duplicates: PCR and optical duplicates will be identified based on read pair mapping positions and marked in the final bam file.

The output of Picard is a bam file (Li et al, 2009) ([samtools.sourceforge.net/SAM1.pdf](http://samtools.sourceforge.net/SAM1.pdf)) that stores the base sequences, quality scores, and alignment details for all reads for the given sample.

Cancer Mutation Detection Pipeline: Tumor and matched normal bam files from the Picard pipeline will be analyzed as described below:

#### 1. Quality Control

(i). Sample mix-up during sequencing will be done by comparing initial SNP fingerprinting done on a sample at a few dozen sites with exome sequencing pileups at those sites.

(ii). Intra-sample tumor/normal mixup will be checked by first comparing the insert size distribution of lanes that correspond to the same library for both tumor and normal samples, and discarding those lanes that have a different distribution.

Bioinformatic analysis will be applied to tumor and matched normal exome samples to get the DNA copy number profiles. Tumor samples should also have more copy number variation than the corresponding normals. Lanes corresponding to normal

samples that do not have flat profiles will be discarded, as will tumor lanes that don't have profiles consistent with other lanes from the same tumor sample will be discarded.

(iii). Tumor purity and ploidy will be estimated based on the bioinformatic-generated copy number profiles.

(iv). ContEst (Cibulskis et al, 2011) will be used to determine the level of cross-sample contamination in samples.

## 2. Local realignment around putative indels

True somatic and germline small indels with respect to the reference genome often result in misalignment and miscalls of missense mutations and indels. This will be corrected for by doing a local realignment using the GATK IndelRealigner module (on the worldwide web at ([www](http://www.broadinstitute.org/gatk))[broadinstitute.org/gatk](http://www.broadinstitute.org/gatk)) (McKenna et al, 2010, Depristo et al, 2011) of all reads that map in the vicinity of putative indels and evaluating them comprehensively to ensure consistency and correctness of indel calls.

## 3. Identification of somatic single nucleotide variations (SSNVs)

Somatic base pair substitutions will be identified by analyzing tumor and matched normal samples from a patient using a Bayesian statistical framework called muTect (Cibulskis et al, 2013). In the preprocessing step, reads with a preponderance of low quality bases or mismatches to the genome are filtered out. Mutect then computes two log-odds (LOD) scores which encapsulate confidence in presence and absence of the variant in the tumor and normal samples respectively. In the post-processing stage candidate mutations are empirically filtered by various criteria to account for artifacts of capture, sequencing and alignment. One such filter, for example, tests for consistency between distributions of orientations of reads that harbor the mutation and the overall orientation distribution of reads that map to the locus to ensure that there is no strand bias. The final set of mutations will then be annotated with the

25

30

24 May 2019

2019203664

Oncotator tool by several fields including genomic region, codon, cDNA and protein changes.

4. Identification of somatic small insertions and deletions

The local realignment output from section 2.2 will be used to predict candidate somatic and germline indels based on assessment of reads supporting the variant exclusively in tumor or both in tumor and normal bams respectively. Further filtering based on number and distribution of mismatches and base quality scores will be done (McKenna et al, 2010, DePristo et al, 2011). All indels will be manually inspected using the Integrated Genomics Viewer (Robinson et al, 2011) (on the worldwide web at ([www](http://www.broadinstitute.org/igv))[broadinstitute.org/igv](http://www.broadinstitute.org/igv)) to ensure high-fidelity calls.

5. Gene fusion detection

The first step in the gene fusion detection pipeline is alignment of tumor RNA-Seq reads to a library of known gene sequences following by mapping of this alignment to genomic coordinates. The genomic mapping helps collapse multiple read pairs that map to different transcript variants that share exons to common genomic locations. The DNA aligned bam file will be queried for read pairs where the two mates map to two different coding regions that are either on different chromosomes or at least 1 MB apart if on the same chromosome. It will also be required that the pair ends aligned in their respective genes be in the direction consistent with coding-->coding 5'-> 3' direction of the (putative) fusion mRNA transcript. A list of gene pairs where there are at least two such 'chimeric' read pairs will be enumerated as the initial putative event list subject to further refinement. Next, all unaligned reads will be extracted from the original bam file, with the additional constraint that their mates were originally aligned and map into one of the genes in the gene pairs obtained as described above. An attempt will then be made to align all such originally unaligned reads to the custom "reference" built of all possible exon-exon junctions (full length,

25

30

boundary-to-boundary, in coding 5'-> 3' direction) between the discovered gene pairs. If one such originally unaligned read maps (uniquely) onto a junction between an exon of gene X and an exon of gene Y, and its mate was indeed mapped to one of the genes X or Y, then such a read will be marked as a "fusion" read. Gene fusion events will be called in cases where there is at least one fusion read in correct relative orientation to its mate, without excessive number of mismatches around the exon:exon junction and with a coverage of at least 10 bp in either gene. Gene fusions between highly homologous genes (ex. HLA family) are likely spurious and will be filtered out.

#### 6. Estimation of clonality

Bioinformatic analysis may be used to estimate clonality of mutations. For example, the ABSOLUTE algorithm (Carter et al, 2012, Landau et al, 2013) may be used to estimate tumor purity, ploidy, absolute copy numbers and clonality of mutations. Probability density distributions of allelic fractions of each mutation will be generated followed by conversion to cancer cell fractions (CCFs) of the mutations. Mutations will be classified as clonal or subclonal based on whether the posterior probability of their CCF exceeds 0.95 is greater or lesser than 0.5 respectively.

#### 7. Quantification of expression

The TopHat suite (Langmead et al, 2009) will be used to align RNA-Seq reads for the tumor and matched normal bams to the hg19 genome. The quality of RNA-Seq data will be assessed by the RNA-SeQC (DeLuca et al, 2012) package. The RSEM tool (Li et al, 2011) will then be used to estimate gene and isoform expression levels. The generated reads per kilobase per million and tau estimates will be used to prioritize neo-antigens identified in each patient as described elsewhere.

2019203664 24 May 2019

## 8. Validation of mutations in RNA-Seq

Mutations that will be identified by analysis of whole exome data (section 2.3) will be assessed for presence in the corresponding RNA-Seq tumor bam file of the patient. For each variant locus, a power calculation based on the beta-binomial distribution will be performed to ensure that there is at least 80% power to detect it in the RNA-Seq data. A capture identified mutation will be considered validated if there are at least 2 reads harboring the mutation for adequately powered sites.

**Selection of Tumor-Specific Mutation-Containing Epitopes:** All missense mutations and neoORFs will be analyzed for the presence of mutation-containing epitopes using the neural-network based algorithm netMHC, provided and maintained by the Center for Biological Sequence Analysis, Technical University of Denmark, Netherlands. This family of algorithms were rated the top epitope prediction algorithms based on a competition recently completed among a series of related approaches (ref). The algorithms were trained using an artificial neural network based approach on multiple different human HLA A and B alleles utilizing over 100,000 measured binding and non-binding interactions.

The accuracy of the algorithms were evaluated by conducting predictions from mutations found in CLL patients for whom the HLA allotypes were known. The included allotypes were A0101, A0201, A0310, A1101, A2402, A6801, B0702, B0801, B1501. Predictions were made for all 9mer and 10 mer peptides spanning each mutation using netMHCpan in mid-2011. Based on these predictions, seventy-four (74) 9mer peptides and sixty-three (63) 10mer peptides, most with predicted affinities below 500 nM, were synthesized and the binding affinity was measured using a competitive binding assay (Sette).

25           The predictions for these peptides were repeated in March 2013 using each of the most  
up to date versions of the netMHC servers (netMHCpan, netMHC and netMHCcons). These  
three algorithms were the top rated algorithms among a group of 20 used in a competition in  
2012 (Zhang et al). The observed binding affinities were then evaluated with respect to each of  
the new predictions. For each set of predicted and observed values, the % of correct predictions  
30 for each range is given, as well as the number of samples. The definition for each range is as  
follows:

2019203664 24 May 2019

0 – 150 Predicted to have an affinity equal to or lower than 150 nM and measured to have an affinity equal to or lower than 150 nM.

0 – 150\*: Predicted to have an affinity equal to or lower than 150 nM and measured to have an affinity equal to or lower than 500 nM.

151 – 500 nM: Predicted to have an affinity greater than 150 nM but equal to or lower than 500 nM and measured to have an affinity equal to or below 500 nM.

FN (> 500 nM): False Negatives – Predicted to have an affinity greater than 500 nM but measured to have an affinity equal to or below 500 nM.

For 9mer peptides (Table 1) , there was little difference between the algorithms, with the slightly higher value for the 151- 500 nM range for netMHC cons not judged to be significant because of the low number of samples.

Table 1

Range (nM)	9mer PAN	9mer netMHC	9mer CONS
0-150	76% (33)	78% (37)	76% (34)
0-150*	91% (33)	89% (37)	88% (34)
151-500	50% (28)	50% (14)	62% (13)
FN (>500)	38% (13)	39% (23)	41% (27)

- 15 For 10mer peptides (Table 2), again there was little difference between the algorithms except that netMHC produced significantly more false positives than netMHCpan or netMMHCcons. However, the precision of the 10mer predictions is slightly lower in the 0 – 150 nM and 0 – 150\* nM ranges and significantly lower in the 151-500 nM range, compared to the 9mers.



2019203664 24 May 2019

Table 2.

Range (nM)	10mer PAN	10mer netMHC	10mer CONS
0-150	53% (19)	50% (16)	59% (17)
0-150*	68% (19)	69% (16)	76% (17)
151-500	35% (26)	42% (12)	35% (23)
FN (>500)	11% (18)	23% (35)	13% (23)

For 10mers, only predictions in the 0 – 150 nM range will be utilized due to the lower than 50% precision for binders in the 151-500 nM range.

The number of samples for any individual HLA allele was too small to draw any conclusions regarding accuracy of the prediction algorithm for different alleles. Data from the largest available subset (0 – 150\* nM; 9mer) is shown in Table 3 as an example.

Table 3

Allele	Fraction correct
A0101	2/2
A0201	9/11
A0301	5/5
A1101	4/4
A2402	0/0
A6801	3/4
B0702	4/4
B0801	1/2
B1501	2/2

- 10 Only predictions for HLA A and B alleles will be utilized as there is little available data on which to judge accuracy of predictions for HLA C alleles (Zhang et al).

2019203664 24 May 2019

An evaluation of melanoma sequence information and peptide binding predictions was conducted using information from the TCGA database. Information from 220 melanomas from different patients revealed that on average there were approximately 450 missense and 5 neoORFs per patient. 20 patients were selected at random and the predicted binding affinities were calculated for all the missense mutations using netMHC (Lundegaard et al *Prediction of epitopes using neural network based methods* J Immunol Methods 374:26 (2011)). As the HLA allotypes were unknown for these patients, the number of predicted binding peptides per allotype was adjusted based on the frequency of that allotype (Bone Marrow Registry dataset for the expected affected dominant population in the geographic area [Caucasian for melanoma]) to generate a predicted number of actionable mutant epitopes per patient. For each of these mutant epitopes (MUT), the corresponding native (WT) epitope binding was also predicted. Utilizing a single peptide for predicted missense binders with  $K_d \leq 500$  nM and a WT/MUT  $K_d$  ratio of  $>5X$  and over-lapping peptides spanning the full length of each neoORF, 80% (16 of 20) of patients were predicted to have at least 20 peptides appropriate for vaccination. For a quarter of the patients, neoORF peptides could constitute nearly half to all of the 20 peptides. Thus, there is an adequate mutational load in melanoma to expect a high proportion of patients to generate an adequate number of immunogenic peptides.

### Example 7: Prioritization of Immunizing Peptides

Peptides for immunization may be prioritized based on a number of criteria: neoORF vs. missense, predicted  $K_d$  for the mutated peptide, the comparability of predicted affinity for the native peptide compared to the mutated peptide, whether the mutation occurs in an oncogenic driver gene or related pathway, and # of RNA-Seq reads (see e.g., FIG. 8).

As shown in FIG. 8, peptides derived from segments of neoORF mutations that are predicted to bind ( $K_d < 500$  nM) may be given the highest priority based on the absence of tolerance for these entirely novel sequences and their exquisite tumor-specificity.

The similar class of missense mutations in which the native peptide is not predicted to bind ( $K_d > 1000$  nM) and the mutated peptide is predicted to bind with strong/moderate affinity ( $K_d < 150$  nM) may be given the next highest priority. This class (Group I discussed above) represents approximately 20% of naturally observed T-cell responses.

2019203664 24 May 2019

The third highest priority may be given to the more tightly binding (< 150 nM) subset of the Group II class discussed above. This class is responsible for approximately almost 2/3 of naturally observed T-cell responses.

All the remaining peptides derived from the neoORF mutations may be given the fourth priority. Despite not being predicted to bind, these are included based on the known false negative rate, potential binding to HLA-C, potential for presence of Class II epitopes and the high value of utilizing totally foreign antigens.

The fifth priority may be given to the subset of Group II with lower predicted binding affinities (150 – 500 nM). This class is responsible for approximately 10% of the naturally observed T-cell responses.

As the predicted affinity decreases, higher stringency may be applied to expression levels. Within each grouping, peptides may be ranked based on binding affinity (e.g., the lowest Kd may have the highest priority). Within a given grouping of missense mutations, oncogenic driver mutations may be given higher priority. A normal human peptidome library of ~12.6 million unique 9 and 10 mers curated from all known human protein sequences (HG19) has been created. Prior to final selection, any potential predicted epitopes derived from a missense mutation and all neoORF regions may be screened against this library, and perfect matches may be excluded. As discussed below, particular peptides predicted to have deleterious biochemical properties may be eliminated or modified.

According to the techniques herein, RNA levels may be analyzed to assess neoantigen expression. For example, RNA-Seq read-count may be used as a proxy to estimate neoantigen expression. However, there is no currently available information to assess the minimum RNA expression level required in a tumor cell needed to initiate cytolysis. Even the level of expression from “pioneer” translation of messages destined for nonsense mediated decay may be sufficient for target generation. Accordingly, the techniques herein initially set broad acceptance limits for RNA levels that may vary inversely with the priority group. As the predicted affinity decreases, higher stringency may be applied to expression levels. One of skill in the art will appreciate that as additional information becomes available, such limits may be adjusted.

Because of the high value of neoORFs as targets due to their novelty and exquisite tumor specificity, neoORFs with predicted binding epitopes ( $K_d \leq 500$  nM) may be utilized even if there are no detectable mRNA molecules by RNA-Seq (Rank 1). Regions of neoORFs without

2019203664 24 May 2019

predicted binding epitopes ( $> 500$  nM), may generally be utilized only if some level of RNA expression is detected (Rank 4). All missense mutations with strong to intermediate predicted MHC binding affinity ( $\leq 150$  nM) may generally be utilized unless there were no RNA-Seq reads (Ranks 2 and 3). For missense mutations with lower predicted binding affinity ( $150 - \leq 500$  nM), these will likely be utilized only if a slightly higher level of RNA expression is detected (Rank 5).

Oncogenic drivers may represent a high priority group. For example, within a given grouping of missense mutations, oncogenic driver mutations may be of higher priority. This approach is based on the observed down-regulation of genes that are targeted by immune pressure (e.g., immunoediting). In contrast to other immune targets where down-regulation may not have a deleterious effect of cancer cell growth, continued expression of oncogenic driver genes may be crucial to cancer cell survival, thus shutting off a pathway of immune escape. Exemplary oncogenic drivers are listed in Table 3-1 (see e.g., Vogelstein et al; GOTERM\_BP Assignment of genes to Gene Ontology Term - Biological Function on the worldwide web at ([www](http://www.geneontology.org))geneontology.org; BIOCARTA Assignment of genes to signaling pathways, on the worldwide web at ([www](http://www.biocarta.com))biocarta.com; KEGG Assignment of genes to pathways according to KEGG pathway database, on the worldwide web at ([www](http://www.genome.jp/kegg/pathway.html))genome.jp/kegg/pathway.html; REACTOME Assignment of genes to pathways according to REACTOME pathways and gene interactions, on the worldwide web at ([www](http://www.reactome.org))reactome.org).

2019203664 24 May 2019

Table 3-1 Exemplary Oncogenic Driver Genes

<u>Gene Symbol</u>	<u>Gene Name</u>	<u># Mutated Tumor Samples**</u>	<u>Onco-gene score*</u>	<u>Tumor Suppressor Gene score*</u>	<u>Classification*</u>	<u>Core pathway</u>	<u>Process</u>
ABL1	c-abl oncogene 1, receptor tyrosine kinase	851	93%	0%	Oncogene	Cell Cycle/Apoptosis	Cell Survival
AKT1	v-akt murine thymoma viral oncogene homolog 1	155	93%	1%	Oncogene	PI3K	Cell Survival
ALK	anaplastic lymphoma receptor tyrosine kinase	189	72%	1%	Oncogene	PI3K; RAS	Cell Survival
AR	androgen receptor	23	54%	0%	Oncogene	Transcriptional Regulation	Cell Fate
BCL2	B-cell CLL/lymphoma 2	45	27%	1%	Oncogene	Cell Cycle/Apoptosis	Cell Survival
BRAF	v-raf murine sarcoma viral oncogene homolog B1	24288	100%	0%	Oncogene	RAS	Cell Survival
CARD11	caspase recruitment domain family, member 11	74	30%	1%	Oncogene	Cell Cycle/Apoptosis	Cell Survival
CBL	Cas-Br-M (murine) ecotropic retroviral transforming sequence	168	57%	9%	Oncogene	PI3K; RAS	Cell Survival
CRLF2	cytokine receptor-like factor 2	10	100%	0%	Oncogene	STAT	Cell Survival
CSF1R	colony stimulating factor 1 receptor	48	50%	15%	Oncogene	PI3K; RAS	Cell Survival
CTNNB1	catenin (cadherin-associated protein), beta 1, 88kDa	3262	92%	1%	Oncogene	APC	Cell Fate
DNMT1	DNA (cytosine-5)-methyltransferase 1	22	36%	5%	Oncogene	Chromatin Modification	Cell Fate
DNMT3A	DNA (cytosine-5)-methyltransferase 3 alpha	788	74%	12%	Oncogene	Chromatin Modification	Cell Fate
EGFR	epidermal growth factor receptor (erythroblastic leukemia viral (v-erb-b) oncogene homolog, avian)	10628	97%	0%	Oncogene	PI3K; RAS	Cell Survival
ERBB2	v-erb-b2 erythroblastic leukemia viral oncogene homolog 2, neuro/glioblastoma derived oncogene homolog (avian)	164	67%	3%	Oncogene	PI3K; RAS	Cell Survival
EZH2	enhancer of zeste homolog 2 (Drosophila)	276	67%	12%	Oncogene	Chromatin Modification	Cell Fate
FGFR2	fibroblast growth factor receptor 2	121	49%	6%	Oncogene	PI3K; RAS ; STAT	Cell Survival
FGFR3	fibroblast growth factor receptor 3	2948	99%	0%	Oncogene	PI3K; RAS ; STAT	Cell Survival

2019203664 24 May 2019

<u>Gene Symbol</u>	<u>Gene Name</u>	<u># Mutated Tumor Samples**</u>	<u>Onco-gene score*</u>	<u>Tumor Suppressor Gene score*</u>	<u>Classification*</u>	<u>Core pathway</u>	<u>Process</u>
FLT3	fms-related tyrosine kinase 3	11520	98%	0%	Oncogene	RAS; PI3K; STAT	Cell Survival
FOXL2	forkhead box L2	330	100%	0%	Oncogene	TGF- $\beta$	Cell Fate
GATA2	GATA binding protein 2	45	53%	4%	Oncogene	NOTCH, TGF- $\beta$	Cell Fate
GNA11	guanine nucleotide binding protein (G protein), alpha 11 (Gq class)	110	92%	1%	Oncogene	PI3K; RAS; MAPK	Cell Survival
GNAQ	guanine nucleotide binding protein (G protein), q polypeptide	245	95%	1%	Oncogene	PI3K; RAS; MAPK	Cell Survival
GNAS	GNAS complex locus	422	93%	2%	Oncogene	APC; PI3K; TGF- $\beta$ , RAS	Cell Survival/Cell Fate
H3F3A	H3 histone, family 3B (H3.3B); H3 histone, family 3A pseudogene; H3 histone, family 3A; similar to H3 histone, family 3B; similar to histone H3.3B	122	93%	0%	Oncogene	Chromatin Modification	Cell Fate
HIST1H3B	histone cluster 1, H3j; histone cluster 1, H3i; histone cluster 1, H3h; histone cluster 1, H3g; histone cluster 1, H3f; histone cluster 1, H3e; histone cluster 1, H3d; histone cluster 1, H3c; histone cluster 1, H3b; histone cluster 1, H3a; histone cluster 1, H2ad; histone cluster 2, H3a; histone cluster 2, H3c; histone cluster 2, H3d	25	60%	0%	Oncogene	Chromatin Modification	Cell Fate
HRAS	v-Ha-ras Harvey rat sarcoma viral oncogene homolog	812	96%	0%	Oncogene	RAS	Cell Survival
IDH1	isocitrate dehydrogenase 1 (NADP+), soluble	4509	100%	0%	Oncogene	Chromatin Modification	Cell Fate
IDH2	isocitrate dehydrogenase 2 (NADP+), mitochondrial	1029	99%	0%	Oncogene	Chromatin Modification	Cell Fate
JAK1	Janus kinase 1	61	26%	18%	Oncogene	STAT	Cell Survival
JAK2	Janus kinase 2	32692	100%	0%	Oncogene	STAT	Cell Survival
JAK3	Janus kinase 3	89	60%	6%	Oncogene	STAT	Cell Survival

2019203664 24 May 2019

<u>Gene Symbol</u>	<u>Gene Name</u>	<u># Mutated Tumor Samples**</u>	<u>Onco-gene score*</u>	<u>Tumor Suppressor Gene score*</u>	<u>Classification*</u>	<u>Core pathway</u>	<u>Process</u>
KIT	similar to Mast/stem cell growth factor receptor precursor (SCFR) (Proto-oncogene tyrosine-protein kinase Kit) (c-kit) (CD117 antigen); v-kit Hardy-Zuckerman 4 feline sarcoma viral oncogene homolog	4720	90%	0%	Oncogene	PI3K; RAS; STAT	Cell Survival
KLF4	Kruppel-like factor 4	61	80%	4%	Oncogene	Transcriptional Regulation; WNT	Cell Fate
KRAS	v-Ki-ras2 Kirsten rat sarcoma viral oncogene homolog	23261	100%	0%	Oncogene	RAS	Cell Survival
MAP2K1	mitogen-activated protein kinase kinase 1	13	67%	0%	Oncogene	RAS	Cell Survival
MED12	mediator complex subunit 12	337	84%	0%	Oncogene	Cell Cycle/Apoptosis; TGF- $\beta$	Cell Survival
MET	met proto-oncogene (hepatocyte growth factor receptor)	159	61%	4%	Oncogene	PI3K; RAS	Cell Survival
MPL	myeloproliferative leukemia virus oncogene	531	96%	0%	Oncogene	STAT	Cell Survival
MYD88	myeloid differentiation primary response gene (88)	134	92%	1%	Oncogene	Cell Cycle/Apoptosis	Cell Survival
NFE2L2	nuclear factor (erythroid-derived 2)-like 2	102	74%	1%	Oncogene	Cell Cycle/Apoptosis	Cell Survival
NRAS	neuroblastoma RAS viral (v-ras) oncogene homolog	2738	99%	0%	Oncogene	RAS	Cell Survival
PDGFRA	platelet-derived growth factor receptor, alpha polypeptide	653	84%	1%	Oncogene	PI3K; RAS	Cell Survival
PIK3CA	phosphoinositide-3-kinase, catalytic, alpha polypeptide	4560	95%	1%	Oncogene	PI3K	Cell Survival
PPP2R1A	protein phosphatase 2 (formerly 2A), regulatory subunit A, alpha isoform	86	85%	2%	Oncogene	Cell Cycle/Apoptosis	Cell Survival
PTPN11	protein tyrosine phosphatase, non-receptor type 11; similar to protein tyrosine phosphatase, non-receptor type 11	410	90%	0%	Oncogene	RAS	Cell Survival
RET	ret proto-oncogene	500	86%	1%	Oncogene	RAS; PI3K	Cell Survival

2019203664 24 May 2019

<u>Gene Symbol</u>	<u>Gene Name</u>	<u># Mutated Tumor Samples**</u>	<u>Onco-gene score*</u>	<u>Tumor Suppressor Gene score*</u>	<u>Classification*</u>	<u>Core pathway</u>	<u>Process</u>
SETBP1	SET binding protein 1	95	25%	4%	Oncogene	Chromatin Modification; Replication	Cell Fate
SF3B1	splicing factor 3b, subunit 1, 155kDa	516	91%	0%	Oncogene	Transcriptional Regulation	Cell Fate
SMO	smoothened homolog (Drosophila)	34	51%	3%	Oncogene	HH	Cell Fate
SPOP	speckle-type POZ protein	35	66%	3%	Oncogene	Chromatin Modification; HH	Cell Fate
SRSF2	SRSF2 serine/arginine-rich splicing factor 2	273	95%	2%	Oncogene	Transcriptional Regulation	Cell Fate
TSHR	thyroid stimulating hormone receptor	301	86%	0%	Oncogene	PI3K; MAPK	Cell Survival
U2AF1	U2 small nuclear RNA auxiliary factor 1	96	92%	1%	Oncogene	Transcriptional Regulation	Cell Fate

### Example 8: Peptide Production and Formulation

GMP neo-antigenic peptides for immunization will be prepared by chemical synthesis Merrifield RB: Solid phase peptide synthesis. I. The synthesis of a tetrapeptide. J. Am. Chem. Soc. 85:2149-54, 1963) in accordance with FDA regulations. Three development runs have been conducted of 20 ~20-30mer peptides each. Each run was conducted in the same facility and utilized the same equipment as will be used for the GMP runs, utilizing draft GMP batch records. Each run successfully produced > 50 mg of each peptide, which were tested by all currently planned release tests (e.g., Appearance, Identify by MS, Purity by RP-HPLC, Content by Elemental Nitrogen, and TFA content by RP-HPLC) and met the targeted specification where appropriate. The products were also produced within the timeframe anticipated for this part of the process (approximately 4 weeks). The lyophilized bulk peptides were placed on a long term stability study and will be evaluated at various time points up to 12 months.

Material from these runs has been used to test the planned dissolution and mixing approach. Briefly, each peptide will be dissolved at high concentration (50 mg/ml) in 100% DMSO and diluted to 2 mg/ml in an aqueous solvent. Initially, it was anticipated that PBS would be used as a diluent, however, a salting out of a small number of peptides caused a visible cloudiness. D5W (5% dextrose in water) was shown to be much more effective; 37 of 40 peptides were successfully diluted to a clear solution. The only problematic peptides are very hydrophobic peptides. The predicted biochemical properties of planned immunizing peptides



2019203664 24 May 2019

will be evaluated and synthesis plans may be altered accordingly (using a shorter peptide, shifting the region to be synthesized in the N- or C-terminal direction around the predicted epitope, or potentially utilizing an alternate peptide). Ten separate peptides in DMSO/D5W were subjected to two freeze/thaw cycles and showed full recovery. Two individual peptides were dissolved in DMSO/D5W and placed on stability at two temperatures (-20°C and -80°C). These peptides will be evaluated (RP-HPLC, MS and pH) for up to 6 months. To date, both peptides are stable at the 12 week time point with additional time points at 24 weeks to be evaluated.

As shown in FIG. 9, the design of the dosage form process is to prepare 4 pools of patient-specific peptides consisting of 5 peptides each. A RP-HPLC assay has been prepared and qualified to evaluate these peptide mixes. This assay achieves good resolution of multiple peptides within a single mix and can also be used to quantitate individual peptides.

Membrane filtration (0.2 µm pore size) will be used to reduce bioburden and conduct final filter sterilization. Four different appropriately sized filter types were initially evaluated and the Pall, PES filter (# 4612) was selected. To date, 4 different mixtures of 5 different peptides each have been prepared and individually filtered sequentially through two PES filters. Recovery of each individual peptide was evaluated utilizing the RP-HPLC assay. For 18 of the 20 peptides, the recovery after two filtrations was >90%. For two highly hydrophobic peptides, the recovery was below 60% when evaluated at small scale but were nearly fully recovered (87 and 97%) at scale. As stated above, approaches will be undertaken to limit the hydrophobic nature of the sequences selected.

GMP neo-antigenic peptides for immunization will be prepared by chemical synthesis Merrifield RB: Solid phase peptide synthesis. I. The synthesis of a tetrapeptide. J. Am. Chem. Soc. 85:2149-54, 1963) in accordance with FDA regulations.

## 25 **Example 9: Endpoint Assessment**

The primary immunological endpoint of this study will be the assessment of T cell response measured by ex vivo IFN-γ ELISPOT. IFN-γ secretion occurs as a result of the recognition of cognate peptides or mitogenic stimuli by CD4<sup>+</sup> and/or CD8<sup>+</sup> T-cells. A multitude of different CD4<sup>+</sup> and CD8<sup>+</sup> determinants will likely be presented to T cells in vivo since the 20-30mer  
30 peptides used for vaccination should undergo processing into smaller peptides by antigen presenting cells. Without being bound by theory, it is believed that the combination of

2019203664 24 May 2019

personalized neo-antigen peptides, which are novel to the immune system and thus not subject to the immune-dampening effects of self-tolerance, and the powerful immune adjuvant poly-ICLC will induce strong CD4<sup>+</sup> and/or CD8<sup>+</sup> responses. The expectation is therefore that T cell responses are detectable ex vivo i.e. without the need for in vitro expansion of epitope specific T cells through short-term culture. Patients will initially be evaluated using the total pool of peptide immunogens as stimulant in the ELISPOT assay. For patients demonstrating a robust positive response, the precise immunogenic peptide(s) will be determined in follow-up analysis. The IFN- $\gamma$  ELISPOT is generally accepted as a robust and reproducible assay to detect ex vivo T cell activity and determine specificity. In addition to the analysis of the magnitude and determinant mapping of the T cell response in peripheral blood monocytes, other aspects of the immune response induced by the vaccine are critical and will be assessed. These evaluations will be performed in patients who exhibit an ex vivo IFN- $\gamma$  ELISPOT response in the screening assay. They include the evaluation of T cell subsets (Th1 versus Th2, T effector versus memory cells), analysis of the presence and abundance of regulatory cells such as T regulatory cells or myeloid derived suppressor cells, and cytotoxicity assays if patient-specific melanoma cells lines are successfully established.

**Example 10: Peptide synthesis**

GMP peptides will be synthesized by standard solid phase synthetic peptide chemistry and purified by RP-HPLC. Each individual peptide will be analyzed by a variety of qualified assays to assess appearance (visual), purity (RP-HPLC), identity (by mass spectrometry), quantity (elemental nitrogen), and trifluoroacetate counterion (RP-HPLC) and released.

The personalized neoantigen peptides may be comprised of up to 20 distinct peptides unique to each patient. Each peptide may be a linear polymer of ~20 - ~30 L-amino acids joined by standard peptide bonds. The amino terminus may be a primary amine (NH<sub>2</sub>-) and the carboxy terminus is a carbonyl group (-COOH). The standard 20 amino acids commonly found in mammalian cells are utilized (alanine, arginine, asparagine, aspartic acid, cysteine, glutamine, glutamic acid, glycine, histidine, isoleucine, leucine lysine, methionine, phenylalanine, proline, serine, threonine, tryptophan, tyrosine, valine). The molecular weight of each peptide varies based on its length and sequence and is calculated for each peptide.

Personalized neoantigen peptides may be supplied as a box containing 2 ml Nunc Cryo vials with color-coded caps, each vial containing approximately 1.5 ml of a frozen DMSO/D5W

2019203664 24 May 2019

solution containing up to 5 peptides at a concentration of 400 ug/ml. There may be 10 – 15 vials for each of the four groups of peptides. The vials are to be stored at -80oC until use. Ongoing stability studies support the storage temperature and time.

**Storage and Stability:** The personalized neoantigen peptides are stored frozen at -80oC. The thawed, sterile filtered, in process intermediates and the final mixture of personalized neoantigen peptides and poly-ICLC can be kept at room temperature but should be used within 4 hours .

**Compatibility:** The personalized neoantigen peptides will be mixed with 1/3 volume poly-ICLC just prior to use.

### **Example 11: Administration**

Following mixing with the personalized neo-antigenic peptides/polypeptides, the vaccine (e.g., peptides + poly-ICLC) is to be administered subcutaneously.

**Preparation of personalized neo-antigenic peptides/polypeptides pools:** peptides will be mixed together in 4 pools of up to 5 peptides each. The selection criteria for each pool will be based on the particular MHC allele to which the peptide is predicted to bind.

**Pool Composition:** The composition of the pools will be selected on the basis of the particular HLA allele to which each peptide is predicted to bind. The four pools will be injected into anatomic sites that drain to separate lymph node basins. This approach was chosen in order to potentially reduce antigenic competition between peptides binding to the same HLA allele as much as possible and involve a wide subset of the patient's immune system in developing an immune response. For each patient, peptides predicted to bind up to four different HLA A and B alleles will be identified. Some neoORF derived peptides will not be associated with any particular HLA allele. The approach to distributing peptides to different pools will be to spread each set of peptides associated with a particular HLA allele over as many of the four pools as possible. It is highly likely there will be situations where there will be more than 4 predicted peptides for a given allele, and in these cases it will be necessary to allocate more than one peptide associated with a particular allele to the same pool. Those neoORF peptides not associated with any particular allele will be randomly assigned to the remaining slots. An example is shown below:

30

24 May 2019

2019203664

A1	HLA A0101	3 peptides
A2	HLA A1101	5 peptides
B1	HLA B0702	2 peptides
B2	HLA B6801	7 peptides
X	NONE (neoORF)	3 peptides

Pool#	1	2	3	4
	B2	B2	B2	B2
	B2	B2	B2	A2
	A2	A2	A2	A2
	A1	A1	A1	B1
	B1	X	X	X

Peptides predicted to bind to the same MHC allele will be placed into separate pools whenever possible. Some of the neoORF peptides may not be predicted to bind to any MHC allele of the patient. These peptides will still be utilized however, primarily because they are completely novel and therefore not subject to the immune-dampening effects of central tolerance and therefore have a high probability of being immunogenic. NeoORF peptides also carry a dramatically reduced potential for autoimmunity as there is no equivalent molecule in any normal cell. In addition, there can be false negatives arising from the prediction algorithm and it is possible that the peptide will contain a HLA class II epitope (HLA class II epitopes are not reliably predicted based on current algorithms). All peptides not identified with a particular HLA allele will be randomly assigned to the individual pools. The amounts of each peptide are predicated on a final dose of 300 µg of each peptide per injection.

For each patient, four distinct pools (labeled “A”, “B”, “C” and “D”) of 5 synthetic peptides each will have been prepared manufacturer and stored at -80°C. On the day of immunization, the complete vaccine consisting of the peptide component(s) and poly-ICLC will be prepared in a laminar flow biosafety cabinet in the research pharmacy. One vial each (A, B, C and D) will be thawed at room temperature and moved into a biosafety cabinet for the remaining steps. 0.75 ml of each peptide pool will be withdrawn from the vial into separate syringes. Separately, four 0.25 ml (0.5 mg) aliquots of poly-ICLC will be withdrawn into separate syringes. The contents of each peptide-pool containing syringe will then be gently

2019203664 24 May 2019

mixed with a 0.25 ml aliquot of poly-ICLC by syringe-to-syringe transfer. The entire one ml of the mixture will be used for injection. These 4 preparations will be labeled “study drug A”, “study drug B”, “study drug C”, and “study drug D”.

**Injections:** At each immunization, each of the 4 study drugs will be injected subcutaneously into one extremity. Each individual study drug will be administered to the same extremity at each immunization for the entire duration of the treatment (i.e. study drug A will be injected into left arm on day 1, 4, 8 etc., study drug B will be injected into right arm on days 1, 4, 8 etc.). Alternative anatomical locations for patients who are status post complete axillary or inguinal lymph node dissection are the left and right midriff, respectively.

Vaccine will be administered following a prime/boost schedule. Priming doses of vaccine will be administered on days 1, 4, 8, 15, and 22 as shown above. In the boost phase, vaccine will be administered on days 85 (week 13) and 169 (week 25).

All patients receiving at least one dose of vaccine will be evaluable for toxicity. Patients will be evaluable for immunologic activity if they have received all vaccinations during the induction phase and the first vaccination (boost) during the maintenance phase.

### **Example 12: Pharmacodynamic Studies**

The immunization strategy is a “prime-boost” approach, involving an initial series of closely spaced immunizations to induce an immune response followed by a period of rest to allow memory T-cells to be established. This will be followed by a booster immunization, and the T-cell response 4 weeks after this boost (16 weeks after the first vaccination) is expected to generate the strongest response and will be the primary immunological endpoint. Immune monitoring will be performed in a step-wise fashion as outlined below to characterize the intensity and quality of the elicited immune responses. Peripheral blood will be collected and PBMC will be frozen at two separate time points prior to the first vaccination (baseline) and at different time points thereafter as illustrated in Schema B and specified in the study calendar. Immune monitoring in a given patient will be performed after the entire set of samples from the induction phase and the maintenance phase, respectively, have been collected. If sufficient

24 May 2019

2019203664

tumor tissue is available, a portion of the tumor will be used to develop autologous melanoma cell lines for use in cytotoxic T-cell assays.

**Example 13: Screening ex vivo IFN- $\gamma$  ELISPOT**

For each patient, a set of screening peptides will be synthesized. The screening peptides will be 15 amino acids in length (occasionally a 16mer or 17mer will be used), overlapping by 11 amino acids and covering the entire length of each peptide or the entire length of the neoORF for neoORF-derived peptides. The entire set of patient-specific screening peptides will be pooled together at approximately equal concentration and a portion of each peptide will also be stored individually. Purity of the peptide pool will be ascertained by testing PBMC from 5 healthy donors with established low background in ex vivo IFN- $\gamma$  ELISPOTs. Initially, PBMC obtained at baseline and at week 16 (the primary immunological endpoint) will be stimulated for 18 hours with the complete pool of overlapping 15-mer peptides (11 amino acids overlap) to examine the global response to the peptide vaccine. Subsequent assays may utilize PBMC collected at other time points as indicated. If no response is identified at the primary immunological endpoint using the ex vivo IFN- $\gamma$  ELISPOT assay, PBMC will be stimulated with the peptide pool for a longer time period (up to 10 days) and re-analyzed.

**Example 14: Deconvolution of epitopes in follow-up ex vivo IFN- $\gamma$  ELISPOT assays.**

20 Once an ex vivo IFN- $\gamma$  ELISPOT response elicited by an overlapping peptide pool is observed (defined as at least 55 spot forming units /  $10^6$  PBMC or increased at least 3 times over baseline), the particular immunogenic peptide eliciting this response will be identified by deconvoluting the peptide pool based into sub-pools based on the immunizing peptides and repeating the ex vivo IFN- $\gamma$  ELISPOT assays. For some responses, an attempt will be made to precisely characterize the stimulating epitope by utilizing overlapping 8-10 mer peptides derived from confirmed, stimulating peptides in IFN- $\gamma$  ELISPOT assays. Additional  
25 assays may be conducted on a case-by case basis for appropriate samples. For example,

2019203664 24 May 2019

- The entire 15mer pool or sub-pools will be used as stimulating peptides for intracellular cytokine staining assays to identify and quantify antigen-specific CD4+, CD8+, central memory and effector memory populations
- Similarly, these pools will be used to evaluate the pattern of cytokines secreted by these cells to determine the T<sub>H</sub>1 vs T<sub>H</sub>2 phenotype
- Extracellular cytokine staining and flow cytometry of unstimulated cells will be used to quantify Treg and myeloid-derived suppressor cells (MDSC).
- If a melanoma cell line is successfully established from a responding patient and the activating epitope can be identified, T-cell cytotoxicity assays will be conducted using the mutant and corresponding wild type peptide
- PBMC from the primary immunological endpoint will be evaluated for “epitope spreading” by using known melanoma tumor associated antigens as stimulants and by using several additional identified mutated epitopes that were not selected to be among the immunogens

Immuno-histochemistry of tumor samples will be conducted to quantify CD4+, CD8+, MDSC, and Treg infiltrating populations.

#### **Example 15: Pipeline for the systematic identification of tumor neoantigens**

Recent advances in sequencing technologies and peptide epitope predictions were leveraged to generate a two-step pipeline to systematically discover candidate tumor-specific HLA-bound neoantigens. As depicted in FIG. 10, this approach starts with DNA sequencing of tumors (e.g., by either whole-exome (WES) or whole-genome sequencing (WGS)) in parallel with matched normal DNA to comprehensively identify non-synonymous somatic mutations (see e.g., Lawrence et al. 2013; Cibulski et al. 2012). Next, candidate tumor specific mutated peptides generated by tumor mutations with the potential to bind personal class I HLA proteins, and hence be presented to CD8<sup>+</sup> T cells, may be predicted using prediction algorithms such as, for example, NetMHCpan (see e.g., Lin 2008; Zhang 2011). Candidate peptide antigens were further evaluated based on experimental validation of their binding to HLA and expression cognate mRNAs in autologous leukemia cells.

30 This pipeline was applied to a large dataset of sequenced CLL samples (see e.g., Wang et

2019203664 24 May 2019

al. 2011). From 91 cases that were sequenced by either WES or WGS, a total of 1838 non-synonymous mutations were discovered in protein-coding regions, corresponding to a mean somatic mutation rate of 0.72 ( $\pm 0.36$  s.d.) per megabase (range, 0.08 to 2.70), and a mean of 20 non-synonymous mutations per patient (range, 2 to 76) (see e.g., Wang et al. 2011). Three general classes of mutations were identified that would be expected to generate regions of amino acid changes and hence potentially be recognized immunologically. The most abundant class included missense mutation that cause single amino acid (aa) changes, representing 90% of somatic mutations per CLL. Of 91 samples, 99% harbored missense mutations and 69% had between 10-25 missense mutations (see e.g., FIG. 2A). The other two classes of mutations, frameshifts and splice-site mutations (mutations at exon-intron junctions) have the potential to generate longer stretches of novel amino acid sequences entirely specific to the tumor (neo-open reading frames, or neoORFs), with a higher number of neoantigen peptides per given alteration (compared to missense mutations). However, consistent with data from other cancer types, neoORF-generating mutations were approximately 10 fold less abundant than missense mutations in CLL (see e.g., FIGS. 2B-C). Given the prevalence of missense mutations, subsequent experimental studies was focused on the analysis of neoepitopes generated by missense mutations.

**Example 16: Somatic missense mutations generate neopeptides predicted to bind to personal HLA class I alleles**

T cell recognition of peptide epitopes by the T cell receptor (TCR) requires the display of peptides bound within the binding groove of HLA molecules on the surface of antigen-presenting cells. Recent comparative studies across the >30 available class I prediction algorithms have shown NetMHCpan to consistently perform with high sensitivity: and specificity across HLA alleles (see e.g., Zhang et al. 2011).

25 The NetMHCpan algorithm was tested against a set of 33 known mutated epitopes that were originally identified in the literature on the basis of their functional activity (i.e., ability to stimulate antitumor cytolytic T cell responses) or were characterized as immunogenic minor histocompatibility antigens to determine whether the algorithm would correctly predict binding for the 33 known mutated epitopes (see e.g., Tables 4 and 5). Tables 4 and 5 show HLA-peptide



2019203664 24 May 2019

binding affinities of known functionally derived immunogenic mutated epitopes across human cancers using NetMHCpan. Table 4 shows epitopes from missense mutations (NSCLC: non-small cell lung cancer; MEL: melanoma; CLL: chronic lymphocytic leukemia; RCC: clear cell renal carcinoma; BLD: bladder cancer; NR: not reported;). Yellow: IC<sub>50</sub> < 150 nM, green: IC<sub>50</sub> 150-500 nM and grey: IC<sub>50</sub> > 500 nM.

2019203664 24 May 2019

Table 4

Group	Gene	Disease	Clinical Response	T cell response MUT>>>WT	HLA Allele	Mutated		Wildtype		W/MUT IC50	Reference
						Observed epitope	Predicted IC50 (nM)	Observed epitope	Predicted IC50 (nM)		
1	ME-1	NSCLC	Yes	Yes	A*02:01	FLDEFMEGV	3	FLDEFMEAV	2	0.7	(50)
	PLEKHM2	MEL	Yes	Yes	A*01:01	LTDDRLLFTCY	3	LTDDRLLFTCH	97	32	(36)
	PRDX5	MEL	NR	Yes	A*02:01	LLDLLLVS	5	LLDLLLVS	7	1.4	(51)
	MATN2	MEL	Yes	Yes	A*11:01	KTLTSVFQK	5	ETLTSVFQK	20	4	(36)
	DDX21	MEL	Yes	Yes	A*68:01	EAFIQPIIR	10	EASIQPIIR	29	3	(52)
	RBAF	MEL	Yes	Yes	B*07:02	RPHVPESAF	10	GPHVPESAF	68	7	(13)
	GAS7	MEL	Yes	Yes	A*02:01	SLADEAEVYL	12	SLADEAEVHL	39	3	(14)
	SIRT2	MEL	Yes	Yes	A*03:01	KIFSEVTLK	14	KIFSEVTPK	16	1.1	(13)
	EF2	NSCLC	NR	Yes	A*68:02	ETVSEQSNV	16	ETVSEESNV	27	2	(53)
	GAPDH	MEL	Yes	Yes	A*02:01	GIVEGLITTV	21	GIVEGLITTV	27	1.3	(14)
	HSP 70	RCC	NR	Yes	A*02:01	SLFEGIDIYT	23	SLFEGIDFYT	7	0.3	(54)
	ACT11N	NSCLC	Yes	Yes	A*02:01	FIASNGVKLV	29	FIASKGVKLV	44	2	(55)
	CDK12	MEL	Yes	Yes	A*11:01	CILGKLFTK	33	CILGELFTK	42	1.3	(36)
	KIAA1440	RCC	Yes	Yes	A*01:01	QTACEVLDY	33	QTTCEVLDY	78	2	(14)
	HAUS3	MEL	Yes	Yes	A*02:01	ILNAMIAMI	34	ILNAMITKI	36	1.1	(36)
	PPP1R3B	MEL	Yes	Yes	A*01:01	YTDHFQGV	49	YTDFFCQVY	72	1.5	(36)
	MUM-2	MEL	Yes	Yes	B*44:02	SELFRRGLDSY	134	SELFRRRLDSY	132	1	(56)
KIAA0205	BLD	NR	Yes	B*44:03	AEPIDIQIW	235	AEPINIQIW	233	1.1	(57)	

Group	Gene	Disease	Clinical Response	T cell response MUT>>>WT	Allele	Mutated		WT/MUT		Reference	
						Observed epitope	Predicted IC50 (nM)	Observed epitope	Predicted IC50 (nM)		
3	GPNMB	MEL	Yes	Yes	A*03:01	TLDWLLQTPK	233	TLGWLLQTPK	175	0.6	(13)
	CSNK1A1	MEL	Yes	Yes	A*02:01	GLFGDIYLAI	6	GSFGDIYLAI	1312	219	(36)
	CLPP	MEL	Yes	Yes	A*02:01	ILDKVLVHL	32	ILDKVLVHP	7565	236	(58)
	CTNWB1	MEL	Yes	Yes	A*24:02	SYLDSGIHF	41	SYLDSGIHS	13746	457	(59)
	SNRP	MEL	Yes	Yes	A*03:01	KILDVVAQK	48	KILDVVAQE	14375	312	(13)
	OS9	MEL	NR	Yes	B*44:03	KELEGILL	60	KELEGILLP	1161	19	(60)
	MYH2	MEL	Yes	Yes	A*03:01	KINKPKYK	141	EINKPKYK	4360	35	(61)
	MART-2	MEL	Yes	Yes	A*01:01	FLEGNEVGKTY	1135	FLGNEVGKT Y	4504	4	(62)
	NFYC	NSCLC	NR	Yes	B*52:01	AQGITKTEV	7374	AQGITQTEV	5701	0.8	(63)
	CDK4	MEL	NR	Yes	A*02:01	ACDPHSGHFV	1132	ARDPHSGHFV	25222	2	(64)

Table 5 shows epitopes from minor histocompatibility antigens (MM: multiple myeloma; HM: hematological malignancy; B-ALL: B cell acute lymphocytic leukemia).

Table 5

Group	Gene	Disease	Clinical Response	T cell response MUT>>>WT	Allele	Mutated		WT/MUT		Reference	
						Observed epitope	Predicted IC50 (nM)	Observed epitope	Predicted IC50 (nM)		
1	ECGF-1	MM	Yes	Yes	B*07:02	RPFAIRRPAL	3	RPRAIRRPAL	2	0.7	(65)
1	KIAA022 3 (HA-1)	HM	Yes	NR	A*02:01	VLHDDLLEA	17	VLRDDLLEA	140	8	(66)
1	BCL2A1	HM	NR	Yes	A*24:02	DYLYVVLQI	22	DYLCQVLQI	34	2	(67)
1	BCL2A1	HM	NR	Yes	A*24:02	KEFEDDIINW	36	KEFEDGINW	27	0.8	(67)
1	HB-1	B-ALL	NR	Yes	B*44:03	EKFRGSLHW	81	EKFRGSLYW	67	1	(68)

2019203664 24 May 2019

Among all tiled 9-mer and 10-mer possibilities, NetMHCpan identified all 33 functionally validated mutated epitopes as the best binding peptide among the possible choices for the given mutation. The median predicted binding affinity (IC<sub>50</sub>) to the known reported HLA restricting elements of each of the 33 mutated epitopes was 32 nM (range, 3-11, 192 nM). By setting the predicted IC<sub>50</sub> cut-offs to 150 and 500 nM, 82 and 91% of the functionally validated peptides, respectively, were captured (see e.g., Tables 4 and 5 and FIG. 12A).

On the basis of its high degree of sensitivity and specificity, NetMHCpan was then applied to the 31 of 91 CLL cases for which HLA typing information was available. By convention, peptides with IC<sub>50</sub> < 150 nM were considered as strong to intermediate binders, IC<sub>50</sub> 150-500 nM as weak binders, and IC<sub>50</sub> > 500 nM as non-binders, respectively (see e.g., Cai et al. 2012). For all 91 CLL cases, a median of 10 strong binding peptides (range, 2-40) and 12 intermediate to weak binding peptides (range, 2-41) was found. In total, a median of 22 (range, 6-81) peptides per case was predicted with IC<sub>50</sub> < 500 nM (see e.g., FIG. 12B and Table 6). In particular, Table 6 shows that the numbers and affinity distributions of peptides predicted from 31 CLL cases with available HLA typing. Patients expressing the 8 most common HLA - A, -B alleles in the Caucasian population are marked in grey.

2019203664 24 May 2019

Table 6.

Pts (f)	HLA -A alleles				HLA -B alleles				Uncommon alleles	# of predicted neopeptides	
	*01:01	*02:01	*24:02	*03:01	*07:02	*08:01	*15:01	*38:01		<150 (nM)	150-500 (nM)
P46										10	12
P31										17	20
P32									B*44:02	13	8
P60									A*68:01	14	19
P5									A*32:01; B*44:02	6	15
P68									A*29:02; B*44:03	17	25
P7									B*38:01; *37:01	8	12
P6									A*31:01; B*14:02	6	8
P14									B*51:01; *62:01	5	4
P26									A*28:01; B*48:01	10	6
P34									B*18:01; *39:05	5	7
P35									B*51:01	11	13
P37									A*03:02; B*44:03	2	4
P43									A*11:01; B*35:03	26	29
P42									A*28:01; B*39:02	10	16
P66									A*23:01; B*49:01	4	8
P62									A*28:01; B*38:06	13	29
P63									B*06:01; *04:01	5	2
P67									A*28:01; *31:01	24	29
P47									A*11:01; B*51:01	10	9
P48									A*11:01; B*51:01	13	17
P16									A*11:01; B*44:02; *51:01	13	12
P36									A*68:01; B*14:02	3	5
P39									A*32:01; B*38:01; *44:01	40	41
P63									A*28:01; B*39:01	13	11
P73									A*31:01; *68:01; B*49:01	18	13
P60									A*29:02; B*45:01; *55:01	3	7
P45									A*68:02; B*44:02; *15:03	5	5
P1									A*11:01; *23:01; B*38:01; *51:01	7	17
P40									A*11:01; *32:01; B*40:01; *44:03	14	16
P41									A*29:03; *32:01; B*44:03	10	8

2019203664 24 May 2019

**Example 17: More than half of predicted HLA-binding neopeptides showed direct binding to HLA proteins in vitro**

As shown in Table 7, IC<sub>50</sub> nM scores generated by HLA-peptide binding predictions were validated using a competitive MHC I allele binding assay and focused on class I-A and -B alleles. To this end, 112 mutated peptides (9 or 10-mer mutated peptides) with predicted IC<sub>50</sub> scores of less than 500 nM that were identified from 4 CLL cases (Pt 1-4) were synthesized. The experimental results correlated with the binding predictions. Experimental binding (defined as IC<sub>50</sub> < 500 nM) was confirmed in 76.5% and 36% of peptides predicted with IC<sub>50</sub> of < 150 nM or 150-500 nM, respectively (see e.g., FIG. 12C). In total, ~54.5% (61/112) of predicted peptides were experimentally validated as binders to personal HLA alleles. Overall, the predictions for 9-mer peptides were more sensitive than for 10-mer peptides, as 60% vs 44.5% of predicted peptides (IC<sub>50</sub> < 500 nM) could be experimentally validated, respectively, as shown in (FIG. 13).

Table 7. Predicted and experimental HLA-binding results of candidate neopeptides generated from 4 CLL cases.

Pt	Gene	Sequence	Length	HLA allele	Candidate neopeptides IC50 (nM)	
					Predicted	Experimental
1	THOC6	ELWCRQPPYR	10	A*33:01	10	18
1	THOC6	ELWCRQPPYR	10	A*68:12	59	5.1
1	CDC25A	QSYCEPSSYR	10	A*68:12	23	1.5
1	ALMS1	TVPSSSFSHR	10	A*68:12	25	11
1	WHSC1L1	EVQASKHTK	9	A*68:12	33	58
1	CRYBA1	WVCYQYSGYR	10	A*33:01	44	972
1	CDC25A	SYCEPSSYR	9	A*33:01	70	14
1	THNSL2	ATIESVQGAK	10	A*68:12	71	42
1	ALMS1	TPTVPSSF	9	B*35:01	75	91
1	RALGAPB	WIMVLVLPK	9	A*68:12	95	218
1	THOC6	ELWCRQPPY	9	B*35:01	112	13776
1	RALGAPB	DWIMVLVLPK	10	A*33:01	117	37826
1	C6orf89	MPIEPGDIGC	10	B*35:01	132	131
1	STRAP	LISACKDGKR	10	A*68:12	163	15845
1	CRYBA1	YQYSGYRGY	9	B*35:01	170	9851
1	WHSC1L1	LLNEVQASK	9	A*68:12	197	7440
1	RALGAPB	DWIMVLVLPK	10	A*68:12	222	2956
1	STRAP	ISACKDGKR	9	A*68:12	224	6671
1	XPO1	KTVVNLKLFK	9	A*68:12	253	25393
1	HMG2	NSAENGDAK	9	A*68:12	258	141
1	THOC6	LWCRQPPYR	9	A*33:01	297	915
1	POLR2A	VQKIFHINPR	10	A*33:01	308	17699
1	CDC25A	QSYCEPSSYR	10	A*33:01	309	53
1	ALMS1	SSSFHIREK	9	A*68:12	314	1496

2019203664 24 May 2019

1	CDC25A	SYCEPSSYR	9	A*68:12	314	812
1	ALMS1	TVPSSFSHR	10	A*33:01	335	237
1	THNSL2	TIESVQGAK	9	A*68:12	338	953
1	POLR2A	MWNVQKIF	9	B*35:01	393	541
1	CDC25A	QSYCEPSSY	9	B*35:01	478	50000
1	DSCAML1	SSIRSFVLQY	10	B*35:01	480	9195
2	NIN	FLQEETLTQM	10	A*02:01	10.63	1.1
2	FNDC3B	VMSWAPPV	9	A*02:01	4.21	6.4
2	SLC46A1	CSDSKLIGY	9	A*01:01	8.13	8.5
2	SYT15	EMLIKPKEL	9	B*08:01	414.37	8.9
2	F2R	ILLMTVTSI	9	A*02:01	41.91	11
2	ACSM2A	SLMEHWALG	9	A*02:01	413.95	17
2	C16orf57	LLRVHTEHV	9	B*08:01	443.97	28
2	ACSM2A	SLMEHWALGA	10	A*02:01	5.67	40
2	TBC1D9B	KMTFLFPNL	9	A*02:01	63.7	62
2	SF3B1	GLVDEQEV	9	A*02:01	22.26	94
2	LRR41	ALPDPILQSI	10	A*02:01	28.18	107
2	LRR41	GWALPDPPI	9	A*02:01	382.07	122
2	FNDC3B	AVVMSWAPPV	10	A*02:01	98.15	123
2	F2R	TSIDRFLAV	9	B*08:01	245.43	130
2	KIAA0467	GPSWGLSLM	9	B*07:02	179.31	137
2	C16orf57	LLRVHTEHV	9	A*02:01	454.23	175
2	C22orf28	WVNCSSMTFL	10	A*02:01	302.94	274
2	FNDC3B	VMSWAPPVGL	10	A*02:01	37.77	378
2	GDF2	ILYKDDMGV	9	A*02:01	13.74	567
2	FNDC3B	NIQARAVVM	9	B*08:01	145.51	743
2	C16orf57	HVRCKSGNKF	10	B*08:01	340.37	803
2	LRR41	LPDPIILQSIL	10	B*07:02	243.46	855



2019203664 24 May 2019

2	F2R	SILLMTVTSI	10	A*02:01	301.24	929
2	ACSM2A	LMEHWALGA	9	A*02:01	314.16	968
2	LRRC41	LPDPILQSI	9	B*07:02	471.62	1056
2	C16orf57	VLLRVHTEHV	10	A*02:01	23.04	1252
2	TBC1D9B	FPNLKDRDFL	10	B*07:02	107.39	1423
2	SYT15	MLIKPKELV	9	A*02:01	162.61	1442
2	ACSM2A	ILCSLMEHWA	10	A*02:01	424.59	1651
2	TBC1D9B	FPNLKDRDF	9	B*07:02	280.32	1687
2	GDF2	SILYKDDMGV	10	A*02:01	140.39	1775
2	TP53	NFRHRVVV	9	B*08:01	285.7	1789
2	SF3B1	EVRTISALAI	10	B*08:01	327.97	2322
2	GDF2	VPTKLSPISI	10	B*07:02	132.77	3416
2	ELK3	LLLQDSECKA	10	A*02:01	437.05	5074
2	KIAA0467	SQPGPSWGL	9	A*02:01	128.72	6511
2	RNF150	KPAVSSDSDI	10	B*07:02	228.47	8085
3	ZNF182	ITHTGEKPY	9	B*15:01	205.26	92
3	ZNF182	ITHTGEKPYK	10	A*03:01	443.32	40
3	ZNF253	KFSNSNIYK	9	A*03:01	116.69	273
3	IREB2	LTRGTFANIK	10	A*01:01	343.52	739
3	TLK2	LTDGFLSKIM	10	A*03:01	164.9	1897
3	TLK2	LTDGFLSKI	10	A*01:01	227	10452
3	TLK2	KLTDGFLSK	9	A*03:01	26	41
3	MYD88	SLSLGAHQK	9	A*03:01	122.42	30
3	PATE2	FLKHKQSCAV	10	B*08:01	17	21
3	PATE2	GMTSCFLK	9	A*03:01	25	29
3	PATE2	FLKHKQSCA	9	B*08:01	19	51
3	JTB	GLLCAFTLK	9	A*03:01	12	62
3	JTB	HLCGLLCAF	9	B*15:01	117	125

2019203664 24 May 2019

3	OR13C5	LSIFKISSL	9	B*08:01	151	158
3	PATE2	VMTSCFLKHK	10	A*03:01	140	174
3	PATE2	MTSCFLKHK	9	A*03:01	147	218
3	OR13C5	KISSEGRSK	10	A*03:01	185	257
3	OR13C5	LSIFKISSL	9	B*15:01	152	368
4	MAPK14	RPTFYRQGL	9	B*07:02	6.7	76
4	SCYL2	EVAGFVFDK	9	A*68:01	7.3	14
4	SCYL2	EVAGFVFDK	10	A*68:01	7.4	8.8
4	COL5A3	FTAGGEPCLY	10	A*01:01	14	153
4	MPDZ	FSIVGGYGR	9	A*68:01	20	2.6
4	CUL1	YMKKAEAPL	9	B*08:01	36	34841
4	MUC2	APIITTTTIV	9	B*07:02	53	13
4	KDM5D	HSIPLRQSVK	10	A*68:01	55	45
4	TBC1D25	ISYLGDRDLR	10	A*68:01	106	556
4	NUP98	APGNITTPA	9	B*07:02	107	13
4	ZNF330	KAFFCDDHTR	10	A*68:01	137	102
4	MPDZ	RPHGDLPIYV	10	B*07:02	155	1321
4	TBC1D25	RLRQEVYLSL	10	B*08:01	165	1084
4	CUL1	YMKKAEAPLL	10	B*08:01	168	138
4	TBC1D25	RLRQEVYLSL	10	B*07:02	183	114
4	LANCL1	CLTKRSIAF	9	B*08:01	205	47
4	COL5A3	FTAGGEPCLY	10	A*68:01	230	11
4	SF3B1	EYVLNTTAR	9	A*68:01	301	651
4	CNN1	DPKLGTAQPL	10	B*07:02	369	3974
4	PPP2R2C	QTHEPEFDY	9	A*01:01	435	26184
4	MUC2	APIITTTTIVT	10	B*07:02	436	3731
4	CUL1	EAPLLEEQR	9	A*68:01	454	36
4	LANCL1	CLTKRSIAFL	10	B*08:01	467	640

4	NUP98	APGENTTPAT	10	B*07:02	475	5744
4	MUC2	TTAPITTTT	9	A*68:01	479	118
4	CUL1	YMKKAEAPL	9	B*07:02	480	7927
4	LOXL2	IPGFKFDNL	9	B*07:02	487	809

\*\* An experimental binding assay for A\*68:12 was not available. Because A\*68:12 and A\*68:01 have identical primary structures in the B and F main peptide binding pockets and have been predicted to have similar binding specificity (Sidney and Sette, 2007), experimental binding for peptides predicted to bind A\*68:12 were assayed against A\*68:01.

2019203664 24 May 2019

**Example 18: Neoantigens are expressed in CLL tumors**

CTL responses against an epitope would only be useful if the gene encoding the epitope is expressed in the target cells. Of the 31 patient samples sequenced and typed for HLA, 26 were subjected to genome-wide expression profiling (see e.g., Brown et al. 2012). The expression level of 347 genes with mutations in CLL samples was classified as having low/absent (lowest quartile), medium (middle two quartiles), or high (highest quartile) expression. As shown in FIG. 12D, 80% of the 347 mutated genes (or 79% of the 180 mutations with predicted HLA-binding) were expressed at medium or high expression levels. A similar high frequency of expression was observed among the subset of 221 mutated genes (88.6%) with predicted class I binding epitopes.

RNA levels may be determined based on the number of reads per gene product, and ranked by quartiles. “H” - Top quartile; “M” – Middle two quartiles; “L” – Lowest quartile (excluding genes with no reads; “-” – no reads detectable. As the predicted affinity decreases, higher stringency may be applied to expression levels. NeoORFs with predicted binders were utilized even if there was no detectable mRNA molecules by RNA-Seq. There is no data currently available to assess what, if any, the minimum expression level required in a tumor cell would be for a neoORF to be useful as a target for activated T-cells. Even the level of expression of “pioneer” translation of messages destined for nonsense mediated decay may be sufficient for target generation ((Chang YF, Imam JS, Wilkinson MF: The nonsense-mediated decay RNA surveillance pathway. *Annu Rev Biochem* 76:51-74, 2007). Therefore, because of the high value of neoORFs as targets due to their novelty and exquisite tumor specificity, neoORFs may be utilized as immunogens even if expression at the RNA level is low or undetectable.

**Example 19: T cells targeting candidate neopeptides were detected in CLL Patient 1 following HSCT**

The post-allogeneic hematopoietic stem cell transplantation (HSCT) setting in CLL was analyzed to determine whether an immune response against the predicted mutated peptides could develop in patients. Reconstitution of T cells from a healthy donor following HSCT can overcome endogenous immune defects of the host, and also allow priming against leukemia cells

2019203664 24 May 2019

in the host in vivo. Analysis focused on two patients who had both undergone unrelated reduced intensity conditioning allo-HSCT for advanced CLL and had achieved continuous remission for greater than 4 years following HSCT (see e.g., Table 8). Post-transplant T cells were collected 7 years (Patient 1) and 4 years (Patient 2) from the time of transplant.

Table 8 shows the clinical characteristics of CLL Pts 1 and 2. Both patients have achieved ongoing continuous remission following HSCT of greater than 7 (Pt 1) and 4 years (Pt 2). M: male; HSCT: hematopoietic stem cell transplantation; RIC: reduced intensity conditioning; Flu/Bu: Fludarabine/Busulfan; GvHD: graft vs host disease; URD: unrelated donor; Mis: missense; FS: frameshift.

Table 8.

Pt	HLA typing	Age/ Sex	Allogeneic HSCT				Number of Mutations				Neopeptides (IC50 < 500 nM)	
			Conditioning regimen	Stem cell source	Days to cGvHD Onset	GvHD meds	Total	Mis	FS	Putative drivers	Predicted	Experimental
1	A*33:01/ *68:12	51/M	RIC	URD	448	Imatinib/ Prednisone	33	25	8	XPO1	30	14
	B*35:01/ *14:01											
2	A*01:01/ *02:01	72/M	RIC	URD	208	Imatinib	27	26	1	TP53, SF3B1	37	18
	B*07:02/ *08:01											

For Patient (Pt 1), 25 missense mutations were identified by WES. In total, 30 peptides from 13 mutations were predicted to bind to personal HLA (13 peptides with IC<sub>50</sub> < 150; 17 peptides with IC<sub>50</sub> 150-500 nM). As shown in FIG. 14A, experimental validation of peptide predictions confirmed HLA binding for 14 peptides derived from 9 mutations. All 30 predicted HLA binding peptides were selected for T cell priming studies, and were organized into 5 pools of 6 peptides/pool (see e.g., Table 9). Peptides with similar predicted binding scores were put together within the same pool.

Table 9 provides a summary of peptides from Pt 1 missense mutations that were included in peptide pools for T cell stimulation studies. In Pt 1, all predicted peptides with IC<sub>50</sub> < 500 nM binding to HLA -A and -B alleles were used. 5 pools of mutated peptides with 6 peptides/pool listed in decreasing order of predicted binding affinities to MHC class I alleles. The corresponding experimental HLA-peptide binding affinities, wildtype peptides and their predicted IC<sub>50</sub> scores are included in the far right columns.

**Table 9.**

Pool	Gene	Length	HLA allele	MUT peptide			WT peptide	
				Sequence	Predicted IC <sub>50</sub> (nM)	Experimental IC <sub>50</sub> (nM)	Sequence	Predicted IC <sub>50</sub> (nM)
1	<i>THOC6</i>	10	A*33:01	ELWCRQPPYR	10	18	ELWRRQPPYR	11
	<i>THOC6</i>	10	A*68:12	ELWCRQPPYR	59	5.1	ELWRRQPPYR	61
	<i>CDC25A</i>	10	A*68:12	QSYCEPSSYR	23	1.5	QSYCEPPSYR	37
	<i>ALMS1</i>	10	A*68:12	TVPSSSFSHR	25	11	TVPSGSFSHR	35
	<i>WHSC1L1</i>	9	A*68:12	EVQASKHTK	33	58	EVQASEHTK	34
	<i>CRYBA1</i>	10	A*33:01	WVCYQYSGYR	44	972	WVCYQYPGYR	50
	<i>CDC25A</i>	9	A*33:01	SYCEPSSYR	70	14	SYCEPPSYR	61
2	<i>THNSL2</i>	10	A*68:12	ATIESVQGAK	71	42	AAIESVQGAK	470
	<i>ALMS1</i>	9	B*35:01	TPTVPSSSF	75	91	TPTVPSGSF	89
	<i>RALGAPB</i>	9	A*68:12	WIMVLVLPK	95	218	WIMALVLPK	46
	<i>THOC6</i>	9	B*35:01	ELWCRQPPY	112	13776	ELWRRQPPY	126
	<i>RALGAPB</i>	10	A*33:01	DWIMVLVLPK	117	37826	DWIMALVLPK	171

2019203664 24 May 2019

	<i>C6orf89</i>	10	B*35:01	MPIEPGDIGC	132	131	MPIEPGDIGY	3
3	<i>STRAP</i>	10	A*68:12	LISACKDGKR	163	15845	LISACKDGKP	38499
	<i>CRYBA1</i>	9	B*35:01	YQYSGYRGY	170	9851	YQYPGYRGY	171
	<i>WHSC1L1</i>	9	A*68:12	LLNEVQASK	197	7440	LLNEVQASE	21454
	<i>RALGAPB</i>	10	A*68:12	DWIMVLVLPK	222	2956	DWIMALVLPK	299
	<i>STRAP</i>	9	A*68:12	ISACKDGKR	224	6671	ISACKDGKP	39393
4	<i>XPO1</i>	9	A*68:12	KTVVNKLFK	253	25393	KTVVNKLFK	18346
	<i>HMG2</i>	9	A*68:12	NSAENGDAK	258	141	NPAENGDAK	3679
	<i>THOC6</i>	9	A*33:01	LWCRQPPYR	297	915	LWRRQPPYR	222
	<i>POLR2A</i>	10	A*33:01	VQKIFHINPR	308	17699	AQKIFHINPR	738
	<i>CDC25A</i>	10	A*33:01	QSYCEPSSYR	309	53	QSYCEPPSYR	398
	<i>ALMS1</i>	9	A*68:12	SSFSHREK	314	1496	SGFSHREK	3554
5	<i>CDC25A</i>	9	A*68:12	SYCEPSSYR	314	812	SYCEPPSYR	597
	<i>ALMS1</i>	10	A*33:01	TVPSSSFHR	335	237	TVPSGSFHR	378
	<i>THNSL2</i>	9	A*68:12	TIESVQGAK	338	953	AIESVQGAK	3861
	<i>POLR2A</i>	9	B*35:01	MIWNVQKIF	393	541	MIWNAQKIF	294
	<i>CDC25A</i>	9	B*35:01	QSYCEPSSY	478	50000	QSYCEPPSY	472
	<i>DSCAML1</i>	10	B*35:01	SSIRSFVLQY	480	9195	SSIRGFVLQY	391

T cells were tested for neoantigen reactivity by expanding them using autologous antigen presenting cells (APCs) pulsed with candidate neoantigen peptide pools (once per week X 4 weeks). As shown in FIG. 14B, reactivity in a IFN- $\gamma$  ELISPOT assay was detected against Pool 2, but not against an irrelevant peptide (Tax peptide). Deconvolution of the pool revealed that the mutated (mut) *ALMS1* and *C6orf89* peptides within Pool 2 were immunogenic. *ALMS1* plays a role in ciliary function, cellular quiescence and intracellular transport, and mutations in this gene have been implicated in type II diabetes. *C6orf89* encodes a protein that interacts with bombesin receptor subtype-3, which is involved in cell cycle progression and wound repair of bronchial epithelial cells. Both mutated sites were not in conserved regions of the gene, and were not within genes previously reported to be mutated in cancer. Both of the target peptides were among the subset of 14 predicted peptides that could be experimentally confirmed to bind



Pt 1's HLA alleles. The experimental binding scores of mut and wildtype (wt) *ALMS1* were 91 and 666 nM, respectively; and of mut- and wt-*C6ORF89*, 131 and 1.7 nM, respectively (see e.g., FIG. 14C and Table 9). Both mutated genes localized to poorly conserved regions and did not localize to previously reported mutation sites in cancers (see e.g., FIGS. 15-16).

**Example 20: CLL Patient 2 exhibited immunity against a mutated *FNDC3B* peptide that is naturally processed**

In Patient 2, the ability personal neoantigens to contribute to memory T responses in the setting of long-lived remission was tested. From this individual, 26 non-synonymous missense mutations were identified. In total, 37 peptides from 16 mutations were predicted to bind to personal HLA alleles, of which 18 peptides from 12 mutations could be experimentally validated (15 with IC50 < 150; 3 with IC50 150-500 nM) (see e.g., FIG. 17A). In Pt 2, all 18 experimentally validated HLA-binding peptides were studied. T cell stimulations were performed using 3 pools of 6 peptides/pool (see e.g., Table 10). Table 10 shows a summary of peptides from Pt 2 missense mutations that were included in peptide pools for T cell stimulation studies. In Pt 2, all peptides that were experimentally confirmed to bind to HLA -A and -B alleles were used. 3 pools of peptides with 6 peptides/pool listed in decreasing order of experimental binding affinity of mutated peptides. The corresponding wildtype peptides and their predicted IC50 scores are included in the far right columns.

Table 10.

Pool	Gene	Length	HLA allele	MUT peptide			WT peptide	
				Sequence	Predicted IC50 (nM)	Experimental IC50 (nM)	Sequence	Predicted IC50 (nM)
1	<i>NIN</i>	10	A*02:01	FLQEETLTQM	10.63	1.1	FLQEERLTQM	45
	<i>FNDC3B</i>	9	A*02:01	VVMSWAPPV	4.21	6.2	VVLSWAPPV	9
	<i>SLC46A1</i>	9	A*01:01	CSDSKLIGY	8.13	8.5	CWDSKLIGY	1778
	<i>SYT15</i>	9	B*080:1	EMLIKPKEL	414.37	8.9	EMLSKPKEL	785
	<i>F2R</i>	9	A*02:01	ILLMTVTSI	41.91	11	ILLMTVISI	53
	<i>ACSM2A</i>	9	A*02:01	SLMEHWALG	413.95	17	SLMEPWALG	1313
2	<i>C16orf57</i>	9	B*080:1	LLRVHTEHV	443.97	28	LLRVHTEQV	498.35

	<i>ACSM2A</i>	10	A*02:01	SLMEHWALGA	5.67	40	SLMEPWALGA	9.8
	<i>TBC1D9B</i>	9	A*02:01	KMTFLFPNL	63.7	62	KMTFLFANL	93
	<i>SF3B1</i>	9	A*02:01	GLVDEQQEV	22.26	94	GLVDEQQKV	51
	<i>LRR41</i>	10	A*02:01	ALPDPILQSI	28.18	107	ALPGPILQSI	99
	<i>LRR41</i>	9	A*02:01	GVWALPDI	382.07	122	GVWALPGPI	963
3	<i>FNDC3B</i>	10	A*02:01	AVVMSWAPPV	98.15	123	AVVLSWAPPV	89
	<i>F2R</i>	9	B*080:1	TSIDRFLAV	245.43	130	ISIDRFLAV	252
	<i>KIAA0467</i>	9	B*07:02	GPSWGLSLM	179.31	137	GPSRGLSLM	39
	<i>C16orf57</i>	9	A*02:01	LLRVHTEHV	454.23	175	LLRVHTEQV	433.02
	<i>C22orf28</i>	10	A*02:01	WVNCSSMTFL	302.94	274	WVNRSSMTFL	835
	<i>FNDC3B</i>	10	A*02:01	VMSWAPPVGL	37.77	378	VLSWAPPVGL	48

Peptides with similar experimental binding scores were combined within the same pool. Responses were assessed after 2 rounds of weekly stimulations of T cells against mutated peptide pool-pulsed autologous APCs, and T cells were found to be reactive against Pool 1, as shown in FIG. 17B. Deconvolution of the pool revealed mut-*FNDC3B* to be the dominant immunogenic peptide among others within this pool (experimental IC<sub>50</sub> of mut- and wt-*FNDC3B* were 6.2 and 2.7 nM, respectively; see e.g., FIG. 17C). The function of *FNDC3B* in blood malignancies is unclear, although down-regulation of *FNDC3B* expression is known to upregulate *miR-143* expression, which has been shown to differentiate prostate cancer stem cells and promote prostate cancer metastasis. Similar to *ALMS1* and *C6orf89*, the mutation in *FNDC3B* neither localized to evolutionarily conserved regions nor was it previously reported in other cancers (see e.g., FIGS. 15 and 16).

T cell reactivity against mut-*FNDC3B* was polyfunctional (secreting GM-CSF, IFN- $\gamma$  and IL-2), and specific to the mut-*FNDC3B* peptide but not its wildtype counterpart. Testing T cell reactivity against different concentrations of mut- and wt-*FNDC3B* peptides revealed a high avidity and specificity of mut-*FNDC3B* reactive T cells. T cell reactivity was abrogated by the presence of class I blocking antibody (W6/32), indicating that T cell reactivity was class I restricted (see e.g., FIGS. 17D-E). Moreover, the mut-*FNDC3B* peptide appeared to be a

naturally processed and presented peptide since T cell reactivity was detected against HLA-A2-expressing APCs that were transfected with a 300 basepair minigene encompassing the region of gene mutation but not the wildtype minigene, as shown in FIG. 17E, right panel.

Using a mut-*FNDC3B*/A2<sup>+</sup>-specific tetramer, a discrete population of mut-*FNDC3B*-reactive CD8<sup>+</sup> T cells was detected within Pool 1-stimulated T cells (2.42% of the population) compared to control PBMCs from a healthy adult HLA-A2<sup>+</sup> volunteer (0.38%), as shown in FIG. 17F. Gene expression analysis of *FNDC3B* in a large dataset of 182 CLL cases (including Pt 2) and 24 CD19<sup>+</sup> B cells collected from normal volunteers revealed this gene to be relatively overexpressed in Patient 2 compared to other CLLs and normal B cells, as shown in FIG. 17G. Accordingly, it is clear that long-lived neoantigen-specific T cells could be tracked in CLL Patient 2.

To define the kinetics of mut-*FNDC3B* specific T cells in relationship to post-HSCT course, Pt 2 T cells isolated from different time points before and after HSCT were stimulated for 2 weeks and then tested for IFN- $\gamma$  reactivity on ELISPOT. The emergence of mut-*FNDC3B*-specific T cells coincided with molecular remission and was sustained over time with continuous remission. As shown in FIG. 18 (top and middle panel), mut-*FNDC3B* T cell responses were not detected before or up to 3 months following HSCT. Molecular remission was first achieved 4 months following HSCT, and mut-*FNDC3B*-specific T cells were then first detected 6 months following HSCT. Antigen-specific reactivity subsequently waned (between 12 and 20 months post-HSCT), but was again strongly detected at 32 months post-HSCT. Based on molecular analysis of the TCR of the mut-*FNDC3B*-specific T cells, V $\beta$ 11 was identified as the predominant CDR3 V $\beta$  subfamily used by the reactive T cells, as shown in FIG. 19 and Table 11). Table 11 shows primers used for amplification of the TCR V $\beta$  subfamily.

Table 11.

Name	Forward primer sequence (5'-3')	Amplicon size (bp)
V $\beta$ 1	GCACAACAGTTCCTGACTTGAC	346

2019203664 24 May 2019

V $\beta$ 2	TCATCAACCATGCAAGCCTGACCT	349
V $\beta$ 3	GTCTCTAGAGAGAAGAAGGAGCGC	346
V $\beta$ 4	ACATATGAGAGTGGATTTGTCATT	378
V $\beta$ 5.1	ATACTTCAGTGAGACACAGAGAAAC	396
V $\beta$ 5.2	TTCCCTAACTATAGCTCTGAGCTG	343
V $\beta$ 6	AGGCCTGAGGGATCCGTCTC	340
V $\beta$ 7	CCTGAATGCCCAACAGCTCTC	347
V $\beta$ 8	ATTTACTTTAACAACAACGTTCCG	404
V $\beta$ 9	CCTAAATCTCCAGACAAAGCTCAC	348
V $\beta$ 10	CCACGGAGTCAGGGGACACAGCAC	313
V $\beta$ 11	TCCAACCTGCAAAGCTTGAGGACT	312
V $\beta$ 12	CATGGGCTGAGGCTGATC	417
V $\beta$ 13.1	CAAGGAGAAGTCCCCAAT	372
V $\beta$ 13.2	GGTGAGGGTACAACCTGCC	390
V $\beta$ 14	GTCTCTCGAAAAGAGAAGAGGAAT	349
V $\beta$ 15	AGTGTCTCTCGACAGGCACAGGCT	352
V $\beta$ 16	AAAGAGTCTAAACAGGATGAGTCC	395
V $\beta$ 17	GGAGATATAGCTGAAGGGTA	372
V $\beta$ 18	GATGAGTCAGGAATGCCAAAGGAA	380
V $\beta$ 19	TCCTCTCACTGTGACATCGGCCCA	322
V $\beta$ 20	AGCTCTGAGGTGCCCCAGAATCTC	370

2019203664 24 May 2019

V $\beta$ 22	AAGTGATCTTGCGCTGTGTCCCCA	490
V $\beta$ 23	AGGACCCCCAGTTCCTCATTTC	435
V $\beta$ 24	CCCAGTTTGGAAAGCCAGTGACCC	509
V $\beta$ 25	TCAACAGTCTCCAGAATAAGGACG	352
<b>Name</b>	<b>Reverse primer sequence (5'-3')</b>	
External C $\beta$	GACAGCGGAAGTGGTTGCGGGGT	
Internal C $\beta$	FAM-CGGGCTGCTCCTTGAGGGGCTGCG	

This molecular information was used to develop a clone-specific nested PCR assay. Applying this assay, it was observed that T cells with the same specificity for mut-*FNDC3B* were not detected in PBMCs (n=3) and CD8<sup>+</sup> T cells of normal healthy volunteers (see e.g., Table 12), but could be detected with similar kinetics as detection of IFN- $\gamma$  secretion following HSCT in the patient as shown in FIG. 18, bottom panel. Although relative numbers of clone-specific T cells declined over time, lower concentrations of peptide antigen could stimulate T cell reactivity at 32 months compared to 6 months post-HSCT, indicating the emergence of potentially more antigen-sensitive memory T cells over time (see e.g., FIG. 18, inset).

10 Table 12 shows detection of mut-*FNDC3B* specific TCR V $\beta$ 11, using T cell receptor-specific primers in Pt 2. A real-time PCR assay was designed to detect the mut-*FNDC3B*-specific TCR V $\beta$ 11 clone. This clone was not detectable in healthy donor PBMCs (n=3) or CD8 T cells, but clearly detectable in cDNA from mut-*FNDC3B* reactive T cells from Pt 2 (at 6 months post-HSCT). The PCR products were normalized over 18S ribosomal RNA. -, negative:  
15 no amplification; +, positive: amplification detected; ++, double positive: amplification detected and amplification level is more than median level of all positive samples.

Table 12.

<i>cDNA</i>	<i>Vβ11 Clone specific</i>	
	<i>PCR</i>	<i>18s ribosomal RNA</i>
T cell clone	++	+
Healthy donor PBMCs (n=3)	-	+
Healthy donor CD8 T cells	-	+

**Example 21: Large numbers of candidate neoantigens were predicted across diverse cancers**

The overall somatic mutation rate of CLL is similar to other blood malignancies, but low in comparison to solid tumor malignancies (see e.g., FIG. 20A). To examine how tumor type and mutation rate impacts the abundance and quality of candidate neoantigens, the pipeline was applied to publicly available WES data from 13 malignancies – including high (melanoma (MEL)), lung squamous (LUSC) and adeno (LUAD) carcinoma, head and neck cancer (HNC), bladder cancer, colon and rectum adenocarcinoma, medium (glioblastoma (GBM), ovarian, clear cell renal carcinoma (clear cell RCC), and breast cancer) and low (CLL and acute myeloid leukemia (AML) cancers. To perform this analysis, a recently described algorithm that enables inference of HLA typing from the WES data was also implemented (Liu et al. 2013).

The overall mutation rate in these solid malignancies was an order of magnitude higher than for CLL and was associated with an increased median number of missense mutations. For example, melanoma displayed a median of 300 (range, 34-4276) missense mutations per case, while RCC had 41 (range, 10-101), respectively. Frameshift and splice-site mutations in RCC and melanoma were increased by only 2-3 fold in frequency as compared to CLL and summed neoORF length per sample were increased only moderately (by 5-13 fold). Overall, the median

2019203664 24 May 2019

number of predicted neopeptides with  $IC_{50} < 500$  nM generated from missense and frameshift events per sample was proportional to the mutation rate; this was approximately 20- and 4-fold higher for melanoma (488; range, 18-5811) and RCC (80; range, 6-407)), respectively, compared to CLL (24; range 2-124). With a more stringent threshold of  $IC_{50} < 150$  nM, the corresponding numbers of predicted neopeptides were 212, 35 and 10 for melanoma, RCC and CLL, respectively, as shown in FIG. 20B and Table 13).

Table 13 shows the distribution of mutation classes, summed neoORF sizes and number of predicted binding peptides across 13 cancers. MEL:melanoma, LUSC: lung squamous cell carcinoma, LUAD: lung adenocarcinoma, BLCA: bladder, HNSC: head and neck cancer, COAD: colon adenocarcinoma, READ: renal adenocarcinoma, GBM: glioblastoma, OV: ovarian, RCC: clear cell renal carcinoma, BRCA: breast, CLL: chronic lymphocytic leukemia, AML: acute myeloid leukemia. \*-predicted number of peptides based on missense and frameshift mutations.

Table 13.

Cancer type	# of mutations/sample median (range)			Splice site	Summed NeoORF length/Sample	# of predicted peptides median (range)*	
	Missense	Frame shift				IC50 < 150 (nM)	IC50 150-500 (nM)
MEL	300 (34- 4276)	2 (0-16)	4 (0-101)	48 (0-425)	212 (10-2566)	488 (18-5811)	
LUSC	212 (0-2397)	3 (0-28)	5 (0-37)	86.5 (0-975)	149.5 (0-1320)	351.5 (0-2946)	
LUAD	172.5 (0-8971)	7 (0-61)	5 (0-127)	173.5 (0-2137)	122 (0-6999)	269.5 (1-16360)	
BLCA	161.5 28-1194)	6 (0-22)	4 (0-22)	152 (0-780)	97 19-1073)	232.5 (59-2337)	
HNSC	95 (2-1400)	5 (0-106)	2 (0-29)	124.5 (0-2585)	66.5 (2-1139)	159.5 (3-2916)	
COAD	93 (32- 5902)	4 (1-182)	0 (0-96)	121 (9-4794)	68 (15-2155)	172 (40-5199)	
READ	72.5 (37-1837)	2 (0-31)	0 (0-2)	51(0-929)	52 (14-1215)	114 (38-2750)	
GBM	47 (0- 169)	2 (0-16)	1 (0-5)	47 (0-539)	39 (0-166)	90 (0-332)	
OV	42 (9-149)	1 (0-7)	1 (0-6)	7.5 (0-328)	30 (3-181)	70 (13-420)	
RCC	41(10-101)	6 (0-22)	1(0-8)	143 (0-813)	35 (2-223)	80 (6-407)	
BRCA	25 (1-300)	2 (0-54)	1 (0-8)	37 (0-1415)	21 (0-346)	47 (0-781)	
CLL	16 (0-75)	1 (0-9)	1 (0-6)	11 (0-427)	10 (0-50)	24 (2-124)	
AML	7 (0-20)	1 (0-2)	0 (0-3)	6 (0-160)	4 (0-19)	8 (0-41)	

\* Refers only to predicted epitopes arising from missense mutations.



**Example 22: Clinical strategies for addressing clonal mutations**

“Clonal” mutations are those that are found in all cancer cells within a tumor, while “subclonal” mutations are those that statistically are not in all cancer cells and therefore are derived from a sub population within the tumor.

According to the techniques herein, bioinformatic analysis may be used to estimate clonality of mutations. For example, the ABSOLUTE algorithm (Carter et al, 2012, Landau et al, 2013) may be used to estimate tumor purity, ploidy, absolute copy numbers and clonality of mutations. Probability density distributions of allelic fractions of each mutation may be generated followed by conversion to cancer cell fractions (CCFs) of the mutations. Mutations may be classified as clonal or subclonal based on whether the posterior probability of their CCF exceeds 0.95 is greater or lesser than 0.5 respectively.

It is contemplated within the scope of the disclosure that a neoantigen vaccine may include peptides to clonal, sub-clonal or both types of mutations. The decision may depend on the disease stage of the patient and the tumor sample(s) sequenced. For an initial clinical study in the adjuvant setting, it may not be necessary to distinguish between the two mutations types during peptide selection, however, one of skill in the art will appreciate that such information may be useful in guiding future studies for a number of reasons.

First, subject tumor cells may be genetically heterogeneous. Multiple studies have been published in which tumors representing different stages of disease progression have been  
20 evaluated for heterogeneity. These include examining the evolution from a pre-malignant disease (Myelodysplastic syndrome) to leukemia (secondary acute myelogenous leukemia [AML]) (Walter et al 2012), relapse following therapy-induced remission of AML(Ding et al 2012), evolution from primary to metastatic breast cancer and medulloblastomas (Ding et al

2019203664 24 May 2019

2012; Wu et al Nature 2012), and evolution from primary to highly metastatic pancreatic and renal cancers (Yachida et al 2012; Gerlinger et al 2012). Most studies utilized genome or exome sequencing but one study also evaluated copy number variations and CpG methylation pattern variations. These studies have shown that genetic events are acquired during cancer cell growth which alter the profile of mutations. Many, and usually most (40 % - 90%), of the earliest detectable mutations (“founder mutations”) persist in all evolved variants but new mutations unique to evolved clones do arise and these may be distinct between different evolved clones. These changes can be driven by host/cancer cell “environmental” pressures and/or therapeutic intervention and thus more highly metastatic disease or prior therapeutic intervention generally lead to more significant heterogeneity.

Second, it is contemplated that a single tumor for each patient may be initially sequenced, which may provide a snapshot of the profile of genetic variation for that particular point in time. The sequenced tumor may be derived from a clinically evident lymph node, in transit/satellite metastasis, or resectable visceral metastasis. None of the initially tested patients will have disease that has clinically progressed to multiple sites; however, it is contemplated that the techniques described herein in will be broadly applicable to patients have cancer that has progressed to multiple sites. Within this tumor cell population, “clonal mutations” may be comprised of both founder mutations and any novel mutations present in the cell that seeded the resected tumor and sub-clonal mutations represent those that evolved during growth of the resected tumor.

Third, the clinically important tumor cells for the vaccine induced T-cells to target are frequently not the resected tumor cells but rather other currently undetectable tumor cells within a given patient. These cells may have spread directly from the primary tumor or from the

24 May 2019

2019203664

resected tumor, may have derived from a dominant or sub-dominant population within the seeding tumor and may have genetically evolved further at the surgically resected site. These events are currently unpredictable.

Thus, for the surgically resected adjuvant setting, there is no a priori way to decide whether mutations found in the resected tumor that are clonal or subclonal represent the optimal choice for targeting other non-resected cancer cells. For example, mutations that are subclonal within the resected tumor may be clonal at other sites if those other sites were seeded from a subpopulation of cells containing the sub-clonal mutation within the resected tumor.

In other disease settings however, such as settings in which patients carry multiple and metastatic lesions, sequencing of more than one lesion (or parts of lesion) or lesions from different time points may provide more information relative to effective peptide selection. Clonal mutations may typically be prioritized in the design of neo-antigen epitopes for the vaccine. In some instances, especially as the tumor evolves and sequencing details from metastatic lesions are evaluated for an individual patient, certain subclonal mutations may be prioritized for consideration as part of peptide selection.

**Example 23: Personalized cancer vaccines stimulate immunity against tumor neoantigens**

The above-described detailed integration of comprehensive bioinformatics with functional data in CLL and other cancers provides several novel biological insights. First, although CLL is a relatively low mutation rate cancer, it was nonetheless possible to identify  
20 epitopes generated by somatic mutations that elicited long-term T cell responses. Whole-exome sequencing data from 31 CLL samples revealed that per case, a median of 22 peptides (range, 6-81) were predicted to bind to personal HLA-A and -B alleles with  $IC_{50} < 500nM$  originating from a median of 16 (range, 2-75) missense mutations. Approximately 75% and half (54.5%) of

2019203664 24 May 2019

predicted peptides with  $IC_{50} < 150$  nM and 500 nM, respectively, were experimentally validated to bind to the patient's HLA alleles. RNA expression analysis showed that nearly 90% of the cognate genes corresponding to the predicted mutated peptides were confirmed to be expressed in CLL cells and expression of a transcript from the mutated allele was detected in each of the three (data not shown) examples tested. Only a fraction of all neoepitopes had generated a spontaneous T-cell response although this response was still detectable years after transplant; ~6% (3/48) of all predicted and tested mutated peptides or 9% (3/32) of experimentally validated and tested mutated peptides stimulated IFN- $\gamma$  secretion responses from patient T cells. This rate of neo-epitope discovery in CLL, a low mutation rate tumor, is remarkably similar to the rates recently reported in melanoma (4.5%, or 11/247 peptides; Robbins PF, Lu YC, El-Gamil M, et al: Mining exomic sequencing data to identify mutated antigens recognized by adoptively transferred tumor-reactive T cells. Nat Med, 2013), a high mutation rate cancer. Hence, functional neoepitopes can be systematically discovered across the broad range of cancers including low mutation rate tumors.

A second key finding is that T cell responses against CLL neoepitopes were long-lived (on the order of several years), associated with continuous disease remission and were generated during *in vitro* stimulation in a timeframe consistent with memory T cell responses. These studies add to the growing literature that responses against tumor neoantigens contribute to efficacious immune responses. Thus, although approximately 5% of predicted peptides generated from missense mutations yielded detectable T cell responses, the kinetics of the response suggest a possible role in ongoing anti-leukemia surveillance functions. The functional impact of neoantigen-directed T-cell responses is supported by a recent study from Castle et al. (Castle JC, Kreiter S, Diekmann J, et al: Exploiting the mutanome for tumor vaccination. Cancer Res

2019203664 24 May 2019

72:1081-1091, 2012) who identified candidate neoepitopes by WES of B16 murine melanoma and prediction of peptide-HLA allele binders. A subset of these predicted epitopes not only elicited immune responses that were specific to the mutated peptide and not the wildtype counterpart, but could also control the disease both therapeutically and prophylactically. While it was difficult to directly compare the relative contributions of tumor neoantigens versus other types of CLL antigens such as overexpressed or shared native antigens (in contrast to melanoma, CLL tumor antigens are not well characterized) or to the GvL response, prior characterization of antigen-specific T cell responses from a melanoma patient with prolonged survival suggest that anti-neoantigen immunity is more prolonged and sustained over time than that against shared overexpressed tumor antigens.

Third, these results highlight the concept that targeting tumor-specific “trunk” mutations can be impactful from the immunologic standpoint. All three of the immunogenic neoantigens (mutated *FND3CB*, *ALMS1*, *C6orf89*) in the two patients appeared to be passenger mutations, not directly contributory to the oncogenic process, and were clonal, affecting the bulk of the cancer mass. Several features of these immunogenic mutations suggest them to be passenger mutations: lack of sequence conservation around the mutation and lack of previously reported mutations in other cancers at the observed sites. Because clonal evolution is a fundamental feature of cancer, it has been posited that immunologic targeting of cancer drivers would have the advantage of minimal antigenic drift, given their essentiality in tumor function that would require them to be maintained in the face of selective pressure. Although such an advantage may be possible, it is apparently not a requirement. Additionally, driver mutations may not necessarily generate immunogenic peptides. For example, the *TP53-S83R* mutation in Patient 2 did not generate a predicted epitope of < 500 nM against any of its class I HLA-A or -B alleles.

2019203664 24 May 2019

Finally, analysis of the binding characteristics of the neoantigen data from the literature (Table 4) as well as the candidate neoepitopes from the data in CLL revealed conceptual insights into the types of point mutations most likely to effectively create a T cell response. It was found that a consistent feature of immunogenic neoepitopes was a predicted binding affinity < 500 nM (3 of 3 of immunogenic CLL peptides and 30 of 33 [91%] of the historical functional neoepitopes) and the majority of these (92%) displayed predicted affinities < 150 nM. Unexpectedly however, in most cases (3 of 3 immunogenic CLL peptides and 27 of 33 [82%] historical functional epitopes), the corresponding wild type epitopes were also predicted to bind with comparable strong/intermediate (< 150 nM, Group 1 in Table 4) or weak (150 – 500 nM, Group 2 in Table 4) affinity. The data support the idea that two types of mutations are commonly observed among naturally occurring T-cell responses to neoantigens: (1) mutations at positions that lead to substantially better binding to the MHC allele (mutated *ALMS1* as well as 6 of 33 (18%) of the historical functionally-identified neoepitopes [‘Group 3’, Table 4]), presumably due to improved interaction with MHC, or (2) mutations at positions that do not significantly interact with MHC but instead presumably alter the T cell receptor binding ((2 of 3 CLL epitopes [*FNDC3B* and *C6orf89*] and 24 of 33 (73%) naturally immunogenic neoepitopes [‘Group 1’ and ‘Group 2’, Table 4]). The distinction between these two types of mutations fits with the concept that the peptide can be considered as a “key”, which must fit both the MHC and the TCR “locks” in order to stimulate cytotoxicity, allowing mutations to independently vary MHC or TCR binding. Excepting the contribution of minor histocompatibility antigens to graft-vs-host disease, there are no reports of auto-immune sequelae linked to neoantigens in these patients, even in those patients where a reaction occurs to a mutated peptide and the cognate native peptide is predicted to be a tight binder. This result is consistent with the idea that MHC-

2019203664 24 May 2019

binding native peptides are normally involved in the negative selection process in which T cells bearing TCRs reactive to these native peptides are thymically deleted or rendered anergic, and yet the T cell repertoire can accommodate the development of a specific immune response to a neoepitope peptide due to an altered presentation of the mutated peptide to the T cell receptor. It is clear that each individual tumor in a patient may harbor a broad spectrum of both shared and personal genetic alterations that may continue to evolve in response to the environment, and that this progression may often lead to resistance to therapy. Given the uniqueness and plasticity of tumors, an optimal therapy may need to be customized based on the exact mutations present in each tumor, and may need to target multiple nodes to avoid resistance. The vast repertoire of human CTLs has the potential to create such a therapy that targets multiple, personalized tumor antigens. As discussed above, the present disclosure shows that it is possible to systematically identify CTL target antigens harboring tumor-specific mutations by using massively parallel sequencing in combination with algorithms that effectively predict HLA-binding peptides. Advantageously, the present disclosure allows tumor neoantigens in a variety of low and high mutation rate cancers to be predicted, and experimentally identifies long-lived CTLs that target leukemia neoantigens in CLL patients. The present disclosure supports the existence of protective immunity targeting tumor neoantigens, and provides a method for selecting neoantigens for personalized tumor vaccines.

20 As discussed in detail above, the techniques described herein were applied to a unique group of CLL patients who developed clinically evident durable remission associated with anti-tumor immune responses following allogeneic-HSCT. These graft-versus-leukemia responses have typically been attributed to allo-reactive immune responses targeting hematopoietic cells. However, the above described results indicate that the GvL response is also associated with

2019203664 24 May 2019

CTLs that recognize personal leukemia neoantigens. These results are consistent with data indicating that the existence of GvL-associated CTLs with specificity for tumor, rather than allo-antigens. It has been postulated that neoantigen-reactive CTLs are important in cancer surveillance because the study of a long-term melanoma survivor found that CTLs targeting neoantigens are significantly more abundant and sustained than those against non-mutated overexpressed tumor antigens (Lennerz V, Fatho M, Gentilini C, et al: The response of autologous T cells to a human melanoma is dominated by mutated neoantigens. Proc Natl Acad Sci U S A 102:16013-8, 2005). The data presented above is consistent with this melanoma study because neoantigen-specific T cell responses in CLL patients were found to be long-lived (on the order of several years) memory T cells (based on their rapid stimulation kinetics *in vitro*) and associated with continuous disease remission. Accordingly, neoantigen-reactive CTLs likely play an active role in controlling leukemia in transplanted CLL patients.

More generally, the abundance of neoantigens across many tumors was estimated and found to be ~1.5 HLA-binding peptides with  $IC_{50} < 500nM$  per point mutation and ~ 4 binding peptides per frameshift mutation. As expected, the rate of predicted HLA binding peptides mirrored the somatic mutation rate per tumor type (see e.g., FIG. 20). Two approaches were used to study the relationship between predicted binding affinity and immunogenic neoantigens that induce CTLs. The above-described techniques were applied to published immunogenic tumor neoantigens (i.e. in which reactive CTLs were observed in patients) demonstrated that the vast majority (91%) of functional neoantigens are predicted to bind HLA with  $IC_{50} < 500nM$  (with ~70% of wild type counterpart epitopes predicted to bind at a similar affinity) (see e.g., Table 4). This test used a gold standard set of neoantigens confirmed that the techniques described herein correctly classify true positives. A prospective prediction of neoepitopes followed by functional



2019203664 24 May 2019

validation showed that 6% (3/48) of predicted epitopes were associated with neoantigen-specific T cell responses in patients -- comparable to the rate of 4.8% found recently for melanoma. The low proportion does not necessarily imply low prediction accuracy for the algorithm. Rather, the number of true neoantigens is greatly underestimated because: (i) allo-HSCT is a general cellular therapy likely to induce only a small number of neoantigen-specific T cell memory clones; and (ii) standard T cell expansion methods are not sensitive enough to detect naïve T cells that represent a much larger part of the repertoire but with much lower precursor frequencies. Although the frequency of CTLs that target neoORFs has yet to be measured, it is specifically contemplated within the scope of the invention that this class of neoantigens may be an excellent candidate neoepitope because it is likely to be more specific (for lack of a wild type counterpart) and immunogenic (as a result of bypassing thymic tolerance).

With the ongoing development of highly powerful vaccination reagents, the present disclosure provides techniques that make it feasible to generate personalized cancer vaccines that effectively stimulate immunity against tumor neoantigens.

## MATERIALS AND METHODS

**Patient samples:** Heparinized blood was obtained from patients enrolled on clinical research protocols at the Dana-Farber Cancer Institute (DFCI). All clinical protocols were approved by the DFCI Human Subjects Protection Committee. Peripheral blood mononuclear cells (PBMCs) from patient samples were isolated by Ficoll/Hypaque density-gradient centrifugation, cryopreserved with 10% DMSO, and stored in vapor-phase liquid nitrogen until the time of analysis. For a subset of patients, HLA typing was performed by either molecular or serological typing (Tissue Typing Laboratory, Brigham and Women's Hospital, Boston, MA).

2019203664 24 May 2019

**Whole exome capture sequencing data for CLL and other cancers:** The list for melanoma was obtained from dbGaP database (phs000452.v1.p1) and for the 11 other cancers, through TCGA (available through the Sage Bionetworks' Synapse resource (on the worldwide web at ([www](http://www.synapse.org/#!/Synapse:syn1729383))synapse.org/#!/Synapse:syn1729383)). The HLA-A, HLA-B and HLA-C loci in 2488 samples across these 13 tumor types were sequenced using a two-stage likelihood based approach, and this data is summarized in Table 14. Briefly, a dedicated sequence library consisting of all known HLA alleles (6597 unique entries), based on the IMGT database, was constructed. From this resource, a secondary library of 38-mers was generated, and putative reads emanating from the HLA locus were extracted from total sequence reads based on perfect matches against it. The extracted reads were then aligned to the IMGT-based HLA sequence library using the Novoalign software (on the worldwide web at ([www](http://www.novocraft.com))novocraft.com), and HLA alleles were inferred through a two-stage likelihood calculation. In the first stage, population-based frequencies were used as priors for each allele and the posterior likelihoods were calculated based on quality and insert size distributions of aligned reads. Alleles with the highest likelihoods for each of HLA-A, B and C genes were identified as the first set of alleles. A heuristic weighting strategy of the computed likelihoods in conjunction with the first set of winners were then used to identify the second set of alleles.

Table 14 shows TCGA patient IDs for neoantigen load estimates across cancers. LUSC (lung squamous carcinoma), LUAD (lung adeno carcinoma), BLCA (bladder), HNSC (head and neck), COAD (colon) and READ (rectum), GBM (glioblastoma), OV (ovarian), RCC (clear cell renal carcinoma), AML (acute myeloid leukemia) and BRCA (breast),

2019203664 24 May 2019

Table 14

TCGA Barcodes	Disease	UUID
TCGA-BL-A0C8-01A-11D-A10S-08	BLCA	134b0a5e-a0ba-444d-bc4b-bdceb02d5b04
TCGA-BL-A13I-01A-11D-A13W-08	BLCA	aa490522-7bb9-4f82-8f19-eaf63f719bfe
TCGA-BL-A13J-01A-11D-A10S-08	BLCA	0c7aca3f-e006-4de3-afc2-20b4f727d4fd
TCGA-BL-A3JM-01A-12D-A21A-08	BLCA	b181ba68-f50f-4faf-b7b5-356e119b5f04
TCGA-BT-A0S7-01A-11D-A10S-08	BLCA	b2e5d244-94c1-4dbf-8d33-34b595903310
TCGA-BT-A0YX-01A-11D-A10S-08	BLCA	d61ccd8c-b798-46e0-aeed-f95b4f3ba4ff
TCGA-BT-A20J-01A-11D-A14W-08	BLCA	1d3c0ff9-d149-4d21-8955-5fb849fc5462
TCGA-BT-A20N-01A-11D-A14W-08	BLCA	341bbffe-7587-4ad0-b3b4-68e64080e216
TCGA-BT-A20O-01A-21D-A14W-08	BLCA	7df63263-de4e-4ed8-804f-9e8fee3be2d5
TCGA-BT-A20P-01A-11D-A14W-08	BLCA	e6c78a98-f45b-482b-a551-4f11b8c1ff8b
TCGA-BT-A20Q-01A-11D-A14W-08	BLCA	8c619cbc-9e91-4716-9711-5236e55d8f46
TCGA-BT-A20R-01A-12D-A16O-08	BLCA	e9bbbf3c-0beb-4f91-92a1-081bff7c4a07
TCGA-BT-A20T-01A-11D-A14W-08	BLCA	301d6ce3-4099-4c1d-8e50-c04b7ce91450
TCGA-BT-A20U-01A-11D-A14W-08	BLCA	4576527b-b288-4f50-a9ea-5d5dede22561
TCGA-BT-A20V-01A-11D-A14W-08	BLCA	973d0577-8ca4-44a1-817f-1d3c1bada151
TCGA-BT-A20W-01A-21D-A14W-08	BLCA	85ccd9b-f787-4701-822f-ae0fce5b4fc5
TCGA-BT-A20X-01A-11D-A16O-08	BLCA	9b4586ee-4091-484f-8be8-5a5196fe7b6f
TCGA-BT-A2LB-01A-11D-A18F-08	BLCA	e7aea186-f13b-43b1-8693-f90f51e005dd
TCGA-BT-A2LD-01A-12D-A20D-08	BLCA	cc95719c-7fcc-4ed7-837e-1840c0a6bc27
TCGA-BT-A3PH-01A-11D-A21Z-08	BLCA	cda1a403-16b6-487c-a82a-c377d1d0f89d
TCGA-BT-A3PJ-01A-21D-A21Z-08	BLCA	b73523d7-f5a5-4140-8537-4df4d1ecf465
TCGA-BT-A3PK-01A-21D-A21Z-08	BLCA	4ad38e8e-e63e-41d9-9216-617be7fa1d75
TCGA-C4-A0EZ-01A-21D-A10S-08	BLCA	b01a7081-8eb5-4728-a517-52156cdf7ed
TCGA-C4-A0F0-01A-12D-A10S-08	BLCA	612fd956-9a41-4201-9d74-6ab50f6ae987
TCGA-C4-A0F1-01A-11D-A10S-08	BLCA	9377460a-8497-41b8-b2c2-5f50cfeda1fe
TCGA-C4-A0F6-01A-11D-A10S-08	BLCA	608f8c75-40e4-44f2-bdde-5f07aa6b4bee
TCGA-C4-A0F7-01A-11D-A10S-08	BLCA	f389176f-d8f3-45c2-aae4-7378a3d6fc7f
TCGA-CF-A1HR-01A-11D-A13W-08	BLCA	69acf4f1-063f-453d-b148-681518c0bc39
TCGA-CF-A1HS-01A-11D-A13W-08	BLCA	b36e672b-c5d8-4481-bbb3-7be805215212
TCGA-CF-A27C-01A-11D-A16O-08	BLCA	acc629cb-ad03-4ccc-9b21-922e4932ef3e
TCGA-CF-A3MF-01A-12D-A21A-08	BLCA	c66c92d5-df65-46e6-861d-d8a98808e6a3
TCGA-CF-A3MG-01A-11D-A20D-08	BLCA	4c89ce08-ed24-4179-8884-4706660b7da8
TCGA-CF-A3MH-01A-11D-A20D-08	BLCA	8867b16f-cd05-41e9-b3ca-4c72a1eb70
TCGA-CF-A3MI-01A-11D-A20D-08	BLCA	0afabd62-8454-41b4-9b02-386681589688
TCGA-CU-A0YN-01A-21D-A10S-08	BLCA	803ab221-b813-4bcc-95a9-1f686d172d3c
TCGA-CU-A0YO-01A-11D-A10S-08	BLCA	e80278f9-2059-4e98-92b2-3e9868fc5818
TCGA-CU-A0YR-01A-12D-A10S-08	BLCA	31382822-3792-47bc-99e8-8a1ee1e4e58b

2019203664 24 May 2019

TCGA-CU-A3KJ-01A-11D-A21A-08	BLCA	e22c6a44-4f8e-44eb-8ca8-dff0f2fc5575
TCGA-DK-A1A3-01A-11D-A13W-08	BLCA	2322f7cd-7d55-4a9f-b7f3-da3068089383
TCGA-DK-A1A5-01A-11D-A13W-08	BLCA	448fe471-3f4e-4dc8-a4e0-6f147dc93abe
TCGA-DK-A1A6-01A-11D-A13W-08	BLCA	df8a913c-5160-4fc5-950d-7c890e24e820
TCGA-DK-A1A7-01A-11D-A13W-08	BLCA	91f458e6-64b7-454d-a542-b0aa23638fd8
TCGA-DK-A1AA-01A-11D-A13W-08	BLCA	804ffa2e-158b-447d-945c-707684134c87
TCGA-DK-A1AB-01A-11D-A13W-08	BLCA	5f0fb2ba-0351-4ce0-8b74-31aa3deecae1
TCGA-DK-A1AC-01A-11D-A13W-08	BLCA	a5dc17f5-abda-4534-b0f8-34b59ed4faa3
TCGA-DK-A1AD-01A-11D-A13W-08	BLCA	32398d56-8668-41b1-9c0b-c6aea6e3e787
TCGA-DK-A1AE-01A-11D-A13W-08	BLCA	abd2d959-d5ed-4eb3-9759-67eb1aa23325
TCGA-DK-A1AF-01A-11D-A13W-08	BLCA	fbdcdf7f9-1901-4e90-8e3c-71b05dc96da1
TCGA-DK-A1AG-01A-11D-A13W-08	BLCA	7d2a22eb-7344-4cba-ad7d-94c3f9ef3d7c
TCGA-DK-A2HX-01A-12D-A18F-08	BLCA	a8f0d416-2102-43ea-9cf1-465c37f9642a
TCGA-DK-A2I1-01A-11D-A17V-08	BLCA	f350676a-e308-42fe-8297-9d18ba7027b1
TCGA-DK-A2I2-01A-11D-A17V-08	BLCA	537e0d59-dd1c-479e-877f-eb9523c0967e
TCGA-DK-A2I4-01A-11D-A21A-08	BLCA	d68074b8-ce96-4dc5-b14c-3bbc7ba92ad9
TCGA-DK-A2I6-01A-12D-A18F-08	BLCA	97a755af-ca00-4116-8a32-0984dbfb1585
TCGA-DK-A3IK-01A-32D-A21A-08	BLCA	f730e341-8102-4405-95e2-46a3455a35cc
TCGA-DK-A3IL-01A-11D-A20D-08	BLCA	4838b5a9-968c-4178-bffb-3fafa1f6dc09
TCGA-DK-A3IM-01A-11D-A20D-08	BLCA	780f4201-4e59-47b8-b3b7-d322a6162b2d
TCGA-DK-A3IN-01A-11D-A20D-08	BLCA	173c1518-6bc6-4e25-a119-de32dab91286
TCGA-DK-A3IQ-01A-31D-A20D-08	BLCA	c3da3cc2-2299-4a3e-9de8-7a1d0a10345d
TCGA-DK-A3IS-01A-21D-A21A-08	BLCA	92a59313-da12-4896-b164-fd2d50684638
TCGA-DK-A3IT-01A-31D-A20D-08	BLCA	07db4596-cb49-4a32-bc99-3b202ffe61a2
TCGA-DK-A3IU-01A-11D-A20D-08	BLCA	52de410f-3ce3-4ee6-87f3-8ec2e829962f
TCGA-DK-A3IV-01A-22D-A21A-08	BLCA	7cecfbbc-5fe4-4413-95fd-07533aacbb73
TCGA-E5-A2PC-01A-11D-A202-08	BLCA	62b9f71c-2dab-455a-a454-579e8843f712
TCGA-FD-A3B3-01A-12D-A202-08	BLCA	8e9fb61d-c90d-440b-857a-12e1048435ea
TCGA-FD-A3B4-01A-12D-A202-08	BLCA	df922c85-5a10-487f-a9d5-220d5090e2e4
TCGA-FD-A3B5-01A-11D-A20D-08	BLCA	d05f9b81-7ba9-4231-aae6-1d2c14df22d7
TCGA-FD-A3B6-01A-21D-A20D-08	BLCA	36524c53-ac54-4a42-a982-bed2e4354268
TCGA-FD-A3B7-01A-31D-A20D-08	BLCA	fc76c5bd-315d-4981-ae53-705f40d2c078
TCGA-FD-A3B8-01A-31D-A20D-08	BLCA	7957bb77-8329-43a0-b1a8-140f2cb6b91b
TCGA-FD-A3N5-01A-11D-A21A-08	BLCA	418a3dec-96ff-4719-becb-e1a8260cce2f
TCGA-FD-A3N6-01A-11D-A21A-08	BLCA	d4615ca0-b5c7-4a5c-8593-bd50034a78ae
TCGA-FD-A3NA-01A-11D-A21A-08	BLCA	d079a32c-270b-4c43-8372-884e8d0c48ed
TCGA-G2-A2EC-01A-11D-A17V-08	BLCA	1376c881-cea5-4470-8dc1-63c69f201570
TCGA-G2-A2EF-01A-12D-A18F-08	BLCA	4e5917bd-2cb1-438c-a46c-5d8ca5b2fd0e
TCGA-G2-A2EJ-01A-11D-A17V-08	BLCA	82f98ff9-7161-45c3-8107-033b47e25f21
TCGA-G2-A2EK-01A-22D-A18F-08	BLCA	eb73bb35-af99-47b8-8bbb-33b5374e5c74
TCGA-G2-A2EL-01A-12D-A18F-08	BLCA	56924619-0724-4b3e-9c53-27c27d3789d6

2019203664 24 May 2019

TCGA-G2-A2EO-01A-11D-A17V-08	BLCA	ebb5cdb6-df4a-436d-b4a6-1655d263e3dd
TCGA-G2-A2ES-01A-11D-A17V-08	BLCA	5c628df6-a848-4177-87b8-714788118980
TCGA-G2-A3IE-01A-11D-A20D-08	BLCA	ebacd09f-c204-4cd2-a087-07bc4f2c5b74
TCGA-GC-A3I6-01A-11D-A20D-08	BLCA	372feefe-ee84-4833-8651-8f023f38a56a
TCGA-GC-A3RB-01A-12D-A21Z-08	BLCA	eaf54383-4286-4416-9b18-be1081797df2
TCGA-GD-A2C5-01A-12D-A17V-08	BLCA	2b142863-b963-4cc9-8f8f-c72503c93390
TCGA-GD-A3OP-01A-21D-A21Z-08	BLCA	3e02d723-691a-448c-85e2-4e39a3696ba5
TCGA-GD-A3OQ-01A-32D-A21Z-08	BLCA	fb985b3d-b0f7-42a0-bc3c-f71d9c5f78d8
TCGA-GD-A3OS-01A-12D-A21Z-08	BLCA	9b3e164d-aaa0-4bb5-b7b8-6264b2746a47
TCGA-GV-A3JV-01A-11D-A21Z-08	BLCA	5fed4b8a-4b59-4424-bb11-bc73ce041361
TCGA-GV-A3JW-01A-11D-A20D-08	BLCA	4534413b-d0d0-4b34-a3d4-f821705485ae
TCGA-GV-A3JX-01A-11D-A20D-08	BLCA	21525d6f-4222-4e0a-9f07-8adbdb55c54f
TCGA-GV-A3JZ-01A-11D-A21A-08	BLCA	074fc904-0a0e-4114-b569-89d51e7a89db
TCGA-GV-A3QG-01A-11D-A21Z-08	BLCA	90534196-b1d8-4054-b4d5-1d29943b52bc
TCGA-GV-A3QI-01A-11D-A21Z-08	BLCA	33a9da52-5471-456f-84cb-13c5de5b0994
TCGA-H4-A2HO-01A-11D-A17V-08	BLCA	2e327841-ee0-42dd-883e-7d5b5a0d3a93
TCGA-H4-A2HQ-01A-11D-A17V-08	BLCA	94108975-b7a0-40ba-ad39-e44cc62e8cc0
TCGA-HQ-A2OE-01A-11D-A202-08	BLCA	61324839-e90a-49f2-a9c9-629d7b125fe9
TCGA-A1-A0SB-01A-11D-A142-09	BRCA	db9d40fb-bfce-4c3b-a6c2-41c5c88982f1
TCGA-A1-A0SD-01A-11D-A10Y-09	BRCA	1847727f-ea57-4e2e-84e5-a10e764c9096
TCGA-A1-A0SE-01A-11D-A099-09	BRCA	0539776c-3943-41d0-972c-8dc833a603e5
TCGA-A1-A0SF-01A-11D-A142-09	BRCA	b291200e-3c22-411a-85d0-fbe1570acda2
TCGA-A1-A0SG-01A-11D-A142-09	BRCA	39642c6d-9191-4746-8a9d-62d437bfdce8
TCGA-A1-A0SH-01A-11D-A099-09	BRCA	473d6ae4-162a-4136-b44f-fad42529a31a
TCGA-A1-A0SI-01A-11D-A142-09	BRCA	e218c272-a7e1-4bc9-b8c5-d2d1c903550f
TCGA-A1-A0SJ-01A-11D-A099-09	BRCA	a55c6a44-c0f5-4300-8df4-4a70befe2d3b
TCGA-A1-A0SK-01A-12D-A099-09	BRCA	d1b43161-cbc1-4bf6-b8bb-a72a2e5e1150
TCGA-A1-A0SM-01A-11D-A099-09	BRCA	2057b341-ff5c-45ef-83bb-005e29b2e740
TCGA-A1-A0SN-01A-11D-A142-09	BRCA	1b8d93f4-acc2-48ee-9ca8-a327eb0463c2
TCGA-A1-A0SO-01A-22D-A099-09	BRCA	b3568259-c63c-4eb1-bbc7-af711ddd33db
TCGA-A1-A0SP-01A-11D-A099-09	BRCA	d3ae9617-b6cd-4d98-b631-39bd4afd3c4e
TCGA-A1-A0SQ-01A-21D-A142-09	BRCA	9055ddce-a0ff-4980-af86-c07f949acbc3
TCGA-A2-A04N-01A-11D-A10Y-09	BRCA	389dd52b-a7b7-46f0-83ae-308e485466a8
TCGA-A2-A04P-01A-31D-A128-09	BRCA	a85cf239-ff51-46e7-9b88-4c2cb49c66b9
TCGA-A2-A04Q-01A-21W-A050-09	BRCA	02eb17d4-9e9e-4e32-96b0-90ccdda3f167
TCGA-A2-A04R-01A-41D-A117-09	BRCA	1f8e4326-dfc7-4635-a9b7-a9207a392748
TCGA-A2-A04U-01A-11D-A10Y-09	BRCA	f819433a-44db-4022-abdb-d6123cfa30b2
TCGA-A2-A04V-01A-21W-A050-09	BRCA	89501861-2778-4b88-9a44-939fed99850d
TCGA-A2-A04W-01A-31D-A10Y-09	BRCA	7822a6b1-68c8-4675-993c-c4b54a510c09
TCGA-A2-A04X-01A-21W-A050-09	BRCA	66a73891-2fea-450c-8224-0865d98b4346
TCGA-A2-A04Y-01A-21W-A050-09	BRCA	3669bbbd-2e75-4b57-a5a8-8eebc25a97c2

2019203664 24 May 2019

TCGA-A2-A0CL-01A-11D-A10Y-09	BRCA	a630ed59-dd23-45e1-aa16-4f7a98e32728
TCGA-A2-A0CM-01A-31W-A050-09	BRCA	fe8023d4-5476-4c58-bf70-cbf65cdd4327
TCGA-A2-A0CP-01A-11W-A050-09	BRCA	a776e274-fe9f-49a9-83ab-95ca6819c96b
TCGA-A2-A0CQ-01A-21W-A050-09	BRCA	fa0d7183-8757-4f95-87b2-2366a1dbd508
TCGA-A2-A0CS-01A-11D-A10Y-09	BRCA	fe96b832-cb86-4499-948a-5124a43d5c95
TCGA-A2-A0CT-01A-31W-A071-09	BRCA	2b412ad8-abda-4cf8-8f68-59dbce80031e
TCGA-A2-A0CU-01A-12W-A050-09	BRCA	a9aa68af-f5fe-4ac0-987f-8af49b85c231
TCGA-A2-A0CV-01A-31D-A10Y-09	BRCA	5d1dead5-d9a5-42d3-a703-4c38ad6e8f57
TCGA-A2-A0CW-01A-21D-A10Y-09	BRCA	da4f0f85-b16f-40fa-95c6-524d70d7ac4d
TCGA-A2-A0CX-01A-21W-A019-09	BRCA	975adb76-3561-41a0-959a-68da470816c7
TCGA-A2-A0CZ-01A-11W-A050-09	BRCA	95d5c606-367a-46b5-b663-dcea3f42e2a2
TCGA-A2-A0D0-01A-11W-A019-09	BRCA	3f20d0fe-aaa1-40f1-b2c1-7f070f93aef5
TCGA-A2-A0D1-01A-11W-A050-09	BRCA	a762809c-15c9-485e-ad7a-ef28427750e9
TCGA-A2-A0D2-01A-21W-A050-09	BRCA	05656575-69e7-4745-a89d-ca0568eb5559
TCGA-A2-A0D3-01A-11D-A10Y-09	BRCA	8183420e-7f44-4024-b3db-6b53ad293988
TCGA-A2-A0D4-01A-11W-A019-09	BRCA	f3accede-1716-4d44-bad4-5427a9ebd675
TCGA-A2-A0EM-01A-11W-A050-09	BRCA	0e01c6b8-9edd-4965-b247-ee7e68124f48
TCGA-A2-A0EN-01A-13D-A099-09	BRCA	12362ad7-6866-4e7a-9ec6-8a0a68df8896
TCGA-A2-A0EO-01A-11W-A050-09	BRCA	8e2f9eb7-0660-47ae-b86e-652e99fa69ca
TCGA-A2-A0EQ-01A-11W-A050-09	BRCA	2c449ea9-c3ff-4726-8566-5933e2b7056d
TCGA-A2-A0ER-01A-21W-A050-09	BRCA	31ed187e-9bfe-4ca3-8cbb-10c1e0184331
TCGA-A2-A0ES-01A-11D-A10Y-09	BRCA	64d42c62-5c2d-49f5-856e-72beef88044d
TCGA-A2-A0ET-01A-31D-A045-09	BRCA	f7b40023-4adc-4c7d-ae73-5c10ddcbc0fb
TCGA-A2-A0EU-01A-22W-A071-09	BRCA	de30da8f-903f-428e-a63d-59625fc858a9
TCGA-A2-A0EV-01A-11W-A050-09	BRCA	9433bf4f-23ba-4fe7-9503-1ad243d74225
TCGA-A2-A0EW-01A-21D-A10Y-09	BRCA	a045a04e-4f7b-4f9a-a733-47ad24475496
TCGA-A2-A0EX-01A-21W-A050-09	BRCA	9308f50c-1320-4c45-acc7-38f43b6f9a36
TCGA-A2-A0EY-01A-11W-A050-09	BRCA	a8cde596-e3f5-4b20-9e7f-45d079893176
TCGA-A2-A0ST-01A-12D-A099-09	BRCA	dd669f44-f64d-4afc-a5ac-5f7769d1db43
TCGA-A2-A0SU-01A-11D-A099-09	BRCA	6ceaf20f-1458-4f7f-954a-e2f58ed163bf
TCGA-A2-A0SV-01A-11D-A099-09	BRCA	6d3206c6-0ca8-4b2b-a160-b1719217f9c7
TCGA-A2-A0SW-01A-11D-A099-09	BRCA	7fbd2807-a5bb-4030-a299-524ec3ab4543
TCGA-A2-A0SX-01A-12D-A099-09	BRCA	b54bc31e-bdcc-4ad5-998e-5a9c542f83bb
TCGA-A2-A0SY-01A-31D-A099-09	BRCA	efaa9c0b-c14b-4141-b48c-cc2c6b89ab73
TCGA-A2-A0T0-01A-22D-A099-09	BRCA	3c107ce4-a6ac-469b-b1c0-cd86674b5766
TCGA-A2-A0T1-01A-21D-A099-09	BRCA	9515373a-d982-45fa-b8f9-363f9ba8649f
TCGA-A2-A0T2-01A-11W-A097-09	BRCA	c7918143-dbce-45b3-8d24-2993a9e2b7f4
TCGA-A2-A0T3-01A-21D-A10Y-09	BRCA	0ca029bb-3b3a-48ec-8ade-5591e8e8629f
TCGA-A2-A0T4-01A-31D-A099-09	BRCA	0f1b1fda-4956-498a-b8ff-e98b5d64e509
TCGA-A2-A0T6-01A-11D-A099-09	BRCA	e4dcb280-c309-4ebb-a58d-e6389a0306ee
TCGA-A2-A0T7-01A-21D-A099-09	BRCA	3ea4d98d-f8d9-433e-94f1-b0199bfd198

2019203664 24 May 2019

TCGA-A2-A0YC-01A-11D-A117-09	BRCA	4cccf7dc-7c53-409f-a6b1-f86e0f07250b
TCGA-A2-A0YD-01A-11D-A10G-09	BRCA	30c9f9e5-90b2-4c73-bce5-eb6a3d31f496
TCGA-A2-A0YF-01A-21D-A10G-09	BRCA	11571107-fe70-4140-afff-f4792a4fd473
TCGA-A2-A0YG-01A-21D-A10G-09	BRCA	bf82035c-9cd1-4355-acdd-8a007708e976
TCGA-A2-A0YH-01A-11D-A10G-09	BRCA	e5558a39-eab2-4216-ba88-b63c2de48b01
TCGA-A2-A0YI-01A-31D-A10M-09	BRCA	6d2ae968-c977-4b65-869a-5e96ff3216e9
TCGA-A2-A0YJ-01A-11D-A10G-09	BRCA	3fe8e99f-dce5-4df9-983e-efe63d56bdd5
TCGA-A2-A0YK-01A-22D-A117-09	BRCA	7c27f81e-62fb-478c-9cee-8e20db9300f2
TCGA-A2-A0YL-01A-21D-A10G-09	BRCA	3cc80b41-603d-4735-85c7-71f540dc6e5c
TCGA-A2-A0YM-01A-11D-A10G-09	BRCA	1125ec93-6d24-4537-9c89-526f2d6b2299
TCGA-A2-A0YT-01A-11D-A10G-09	BRCA	827c6a2f-fb1b-4845-9cb1-11013a16da3f
TCGA-A2-A1FV-01A-11D-A13L-09	BRCA	51b7064c-d9fc-4312-ad25-b014ef81c821
TCGA-A2-A1FW-01A-11D-A13L-09	BRCA	6ccdb42e-1ad1-4175-b83a-a24b019dc640
TCGA-A2-A1FX-01A-11D-A13L-09	BRCA	0d3dd7a0-ad8d-46cc-86c4-c1994a7b4b74
TCGA-A2-A1FZ-01A-51D-A17G-09	BRCA	0f7038bb-fd25-468e-8bd9-dcd4312d13cb
TCGA-A2-A1G0-01A-11D-A13L-09	BRCA	f7eacf95-478d-4d81-a5e3-f5a8938c83ec
TCGA-A2-A1G1-01A-21D-A13L-09	BRCA	afe70076-1044-4fdd-bebc-14a97b1a8363
TCGA-A2-A1G4-01A-11D-A13L-09	BRCA	420a4771-6376-4b52-a2e3-e62aaf4d4ed6
TCGA-A2-A1G6-01A-11D-A13L-09	BRCA	c012bce9-de13-4e32-a29e-8ab64e16ea96
TCGA-A2-A259-01A-11D-A16D-09	BRCA	93febb0a-587c-47f2-9a59-117f7aa475c5
TCGA-A2-A25A-01A-12D-A16D-09	BRCA	5739a7e1-7fa3-434c-b1c3-c0a9e570c858
TCGA-A2-A25B-01A-11D-A167-09	BRCA	6e839eaf-1dbb-43f5-8846-c980e05540c7
TCGA-A2-A25C-01A-11D-A167-09	BRCA	2411fc4a-c0d7-4a60-a861-f4d954ef1ed5
TCGA-A2-A25D-01A-12D-A16D-09	BRCA	56b152c3-9de5-4b1c-b6b4-0116cb7ce097
TCGA-A2-A25E-01A-11D-A167-09	BRCA	8dce6a9d-ecb7-4699-9fda-1b09b1b1de43
TCGA-A2-A25F-01A-11D-A167-09	BRCA	1ed40576-4f1c-4cf6-8eea-e816c5d73d90
TCGA-A7-A0CD-01A-11W-A019-09	BRCA	d29ba065-28ca-4dfb-9588-06be857f67b2
TCGA-A7-A0CG-01A-11W-A019-09	BRCA	351275c7-70ca-4ddc-be76-a6ff4dc7655e
TCGA-A7-A0CJ-01A-21W-A019-09	BRCA	c9f6a65e-ae20-410d-a397-34aef0818ff3
TCGA-A7-A0DA-01A-31D-A10Y-09	BRCA	878337fe-9f41-44f5-9760-3977e7d75308
TCGA-A7-A13D-01A-13D-A12Q-09	BRCA	418e916b-7a4e-4fab-8616-15dcec4d79f8
TCGA-A7-A13G-01A-11D-A13L-09	BRCA	ef847b83-eb88-435b-bcfd-4b51d4dfa5fe
TCGA-A7-A26E-01A-11D-A167-09	BRCA	73651880-cfbd-4f8d-8031-a14b3ac65454
TCGA-A7-A26F-01A-21D-A167-09	BRCA	fc73db72-d0ac-48d0-b809-2f7540482ec5
TCGA-A7-A26G-01A-21D-A167-09	BRCA	36d1a85e-a09b-4537-86e0-eaf1eb03aed8
TCGA-A7-A26H-01A-11D-A167-09	BRCA	fbeade79-28ef-4e85-8282-67e691630ca3
TCGA-A7-A26I-01A-11D-A167-09	BRCA	81fff2d1-d6ed-4963-a5f6-5899cde6b359
TCGA-A7-A26J-01A-11D-A167-09	BRCA	be2ca34f-5c15-4b38-a207-52df296a98ee
TCGA-A8-A06N-01A-11W-A019-09	BRCA	03d266a3-eb3e-4893-af6b-cb70d197d98f
TCGA-A8-A06O-01A-11W-A019-09	BRCA	29cd408e-a04b-418a-85e2-6ef95840ddbc
TCGA-A8-A06P-01A-11W-A019-09	BRCA	239b3d55-c5d6-4478-9b7b-1cbad3c03c81

2019203664 24 May 2019

TCGA-A8-A06Q-01A-11W-A050-09	BRCA	473d5422-978a-48be-be32-2b7516d6d2d5
TCGA-A8-A06R-01A-11D-A015-09	BRCA	c6b00eff-6c4e-4d79-a9b1-8fb1f3090816
TCGA-A8-A06T-01A-11W-A019-09	BRCA	11ec4a6f-f2dc-4b0b-9ba5-6fea8222e2d7
TCGA-A8-A06U-01A-11W-A019-09	BRCA	277c2e8a-dd28-4b8f-96d3-ea790a1986b6
TCGA-A8-A06X-01A-21W-A019-09	BRCA	dc306402-3a55-4996-b786-f3f738f13dd3
TCGA-A8-A06Y-01A-21W-A019-09	BRCA	3bede568-d8b6-44c0-99e0-a9b6c7d4ce80
TCGA-A8-A06Z-01A-11W-A019-09	BRCA	f540c4f8-75b3-47d7-a7cf-53cbf7a2c814
TCGA-A8-A075-01A-11D-A099-09	BRCA	085dd125-1f95-46aa-a480-2965090e8591
TCGA-A8-A076-01A-21W-A019-09	BRCA	dfa06058-320b-4cc6-ac18-a42e59019b1c
TCGA-A8-A079-01A-21W-A019-09	BRCA	06221ce8-ab65-4694-945b-059b9c15ede4
TCGA-A8-A07B-01A-11W-A019-09	BRCA	734421b9-ed55-45b0-9ad5-51bc754ebe90
TCGA-A8-A07C-01A-11D-A045-09	BRCA	6ab33f67-b69d-4a2d-a424-841f5fbf1ee7
TCGA-A8-A07E-01A-11W-A050-09	BRCA	fa018a20-2c26-4d47-831f-75280b6464df
TCGA-A8-A07F-01A-11W-A019-09	BRCA	73d907e6-4ba0-431f-a009-8366644ffaf0
TCGA-A8-A07G-01A-11W-A050-09	BRCA	49f77aa5-446b-49f6-bd1b-02d3ff7b9dfc
TCGA-A8-A07I-01A-11W-A019-09	BRCA	7718c3f0-1c90-4940-bc30-ea4f417851bb
TCGA-A8-A07J-01A-11W-A019-09	BRCA	c8eac36c-c3a7-4c88-b928-832ab279045b
TCGA-A8-A07L-01A-11W-A019-09	BRCA	4cc86f29-061e-4058-8e8f-4c48191f52aa
TCGA-A8-A07O-01A-11W-A019-09	BRCA	4574b64d-8848-46e4-913e-5d318c1f6162
TCGA-A8-A07P-01A-11W-A019-09	BRCA	2b88ff64-bf43-43e8-9ea9-0de571520d72
TCGA-A8-A07R-01A-21W-A050-09	BRCA	f377217c-399f-4b3f-9090-fa5189b2bfc6
TCGA-A8-A07U-01A-11W-A050-09	BRCA	e6409415-8453-489d-a731-49257cade2a3
TCGA-A8-A07W-01A-11W-A019-09	BRCA	9bc8dbab-c700-498c-8ff7-ccc62c911349
TCGA-A8-A07Z-01A-11W-A019-09	BRCA	e4af33f9-f5fe-4e52-8ca0-991bbce2270d
TCGA-A8-A081-01A-11W-A019-09	BRCA	d29c3a5b-aab5-4d1b-bdaf-eb6fa405bc80
TCGA-A8-A082-01A-11W-A019-09	BRCA	575d25ea-eae7-423a-9464-d3b2806bf9eb
TCGA-A8-A083-01A-21W-A019-09	BRCA	1904e458-1a6c-4e91-88cc-10ee154ded5b
TCGA-A8-A084-01A-21W-A019-09	BRCA	6f6f7048-5b7a-4827-af2b-cfecc4a60025
TCGA-A8-A085-01A-11W-A019-09	BRCA	cbdea951-3dc9-42c2-bfdd-3796c30e928e
TCGA-A8-A086-01A-11W-A019-09	BRCA	13d89926-9e4c-434f-80b4-4fb15e4426f6
TCGA-A8-A08A-01A-11W-A019-09	BRCA	0257d030-6d78-452c-9dcc-79fe50533543
TCGA-A8-A08B-01A-11W-A019-09	BRCA	267a951b-29b7-4849-9ea7-d2205838fcc7
TCGA-A8-A08F-01A-11W-A019-09	BRCA	4975eeda-984e-4a7a-8193-43d8b6e0271c
TCGA-A8-A08G-01A-11W-A019-09	BRCA	8da61928-e935-4a33-8e46-840e637163d7
TCGA-A8-A08H-01A-21W-A019-09	BRCA	26161c06-f816-489a-8800-e0a68a4ce78a
TCGA-A8-A08I-01A-11W-A019-09	BRCA	4525400d-0a2c-4cc7-9c71-9ad6d9faf93f
TCGA-A8-A08J-01A-11W-A019-09	BRCA	ae458901-e900-4aaa-bde6-3eda8912fbd5
TCGA-A8-A08L-01A-11W-A019-09	BRCA	8b819a59-f0c1-456a-9e81-64b5bed025c1
TCGA-A8-A08O-01A-21W-A071-09	BRCA	bc1398b9-d4ec-43e8-86bc-7025afaf93d5
TCGA-A8-A08P-01A-11W-A019-09	BRCA	2fbe3da3-ce62-4edf-933b-367f983e221a



2019203664 24 May 2019

TCGA-A8-A08R-01A-11W-A050-09	BRCA	05362091-8e04-46e2-81e7-1efddc0d8c63
TCGA-A8-A08S-01A-11W-A050-09	BRCA	9c981525-80af-4f79-b94a-be00131ab872
TCGA-A8-A08T-01A-21W-A019-09	BRCA	af5f43d9-5ff3-4fd8-9c1c-30a88d2bab8e
TCGA-A8-A08X-01A-21W-A019-09	BRCA	67c7d350-5c82-49b0-a7eb-6ca829ffcbc9
TCGA-A8-A08Z-01A-21W-A019-09	BRCA	96afb6d0-29ea-4bd5-8a9d-130e42954707
TCGA-A8-A090-01A-11W-A019-09	BRCA	783e4c13-8fa5-4591-9453-1e59ca167e10
TCGA-A8-A091-01A-11W-A019-09	BRCA	6618f367-c782-43a0-b5c8-a53d9bda6722
TCGA-A8-A092-01A-11W-A019-09	BRCA	732dd0ab-c869-4d35-973f-9db064680fb1
TCGA-A8-A093-01A-11W-A019-09	BRCA	8f64ba22-0958-4fdb-8161-f83cfe57c95d
TCGA-A8-A094-01A-11W-A019-09	BRCA	ab9bf7a6-688e-4388-9682-6b1616723fde
TCGA-A8-A095-01A-11W-A019-09	BRCA	d16f025a-4187-4632-b833-02a3ffa54210
TCGA-A8-A096-01A-11W-A019-09	BRCA	8a411a0a-ec66-4d9f-b0e4-f1c1f969d605
TCGA-A8-A097-01A-11W-A050-09	BRCA	15ca7c47-131a-4dd7-b0a7-584577b4b02c
TCGA-A8-A099-01A-11W-A019-09	BRCA	1066cb38-e051-42fa-a8bc-20b659c17a13
TCGA-A8-A09A-01A-11W-A019-09	BRCA	ecfedc29-5c31-4d3d-b599-fc0a1c0beafa
TCGA-A8-A09B-01A-11W-A019-09	BRCA	a8be37d2-2743-4fde-9aae-2623b5a03b60
TCGA-A8-A09C-01A-11W-A019-09	BRCA	b56cf2cb-bb2a-46b6-b3b4-84dd8b364984
TCGA-A8-A09D-01A-11W-A019-09	BRCA	d0ef396f-4e9f-40ba-a09c-0a96832cabf9
TCGA-A8-A09E-01A-11W-A019-09	BRCA	d6465963-5ea6-44a5-96b0-dff0b0fae4c4
TCGA-A8-A09G-01A-21W-A019-09	BRCA	3bd68e94-d902-4079-8fdb-16edcc90de1c
TCGA-A8-A09I-01A-22W-A050-09	BRCA	96d5070d-1fa9-4fa5-b2c9-472240dfd3b9
TCGA-A8-A09K-01A-11W-A019-09	BRCA	d8cd75f2-5ee5-4296-a781-a6a16ee94506
TCGA-A8-A09M-01A-11W-A019-09	BRCA	8e92515a-8049-4ebb-9117-a137c06e5d04
TCGA-A8-A09N-01A-11W-A019-09	BRCA	304a2945-f134-45c7-9eaa-c6c9c2435552
TCGA-A8-A09Q-01A-11W-A019-09	BRCA	51a8ac83-bafa-4df7-a52d-ale1fb45799d
TCGA-A8-A09R-01A-11W-A019-09	BRCA	35ebf91d-6fec-4d28-9b21-493d0e14f8db
TCGA-A8-A09T-01A-11W-A019-09	BRCA	e565da2b-4a3f-4be1-9cf7-2845145d1dbc
TCGA-A8-A09V-01A-11D-A045-09	BRCA	818f1a34-17c5-409a-b5f5-4a8576db0d44
TCGA-A8-A09W-01A-11W-A019-09	BRCA	9a2690ce-485f-4d4f-9673-d86f91be27a4
TCGA-A8-A09X-01A-11W-A019-09	BRCA	48e532ea-2af5-427a-a784-781e208ccd6
TCGA-A8-A0A1-01A-11W-A019-09	BRCA	73aa20fe-b74b-41ae-88d3-2d5a66908c25
TCGA-A8-A0A2-01A-11W-A050-09	BRCA	b681dba3-a608-47c2-9ae8-5d761d1e800e
TCGA-A8-A0A4-01A-11W-A019-09	BRCA	1fc4d542-86ac-42bc-9fbb-272c23e6aa72
TCGA-A8-A0A7-01A-11W-A019-09	BRCA	28be7b14-730d-44f7-bf93-a7590b4a08f8
TCGA-A8-A0A9-01A-11W-A019-09	BRCA	228e66eb-1dc6-4c01-8252-c557a8f53916
TCGA-A8-A0AB-01A-11W-A050-09	BRCA	ad2a2f5d-dad6-4c03-b235-20810d6d34dc
TCGA-A8-A0AD-01A-11W-A071-09	BRCA	6e6511fa-4f6e-4184-84b8-9e9e7a863632
TCGA-AC-A23C-01A-12D-A167-09	BRCA	91766158-e175-4270-bc01-8e853fc9f391
TCGA-AC-A23E-01A-11D-A159-09	BRCA	137cb73f-394a-459a-83e6-0b3c85c955cd
TCGA-AN-A03X-01A-21W-A019-09	BRCA	f177234e-e0a7-4f85-b73d-48e0080c805d
TCGA-AN-A03Y-01A-21W-A019-09	BRCA	f4849adc-b6e8-40bd-9de4-dc5bb37d2a79

2019203664 24 May 2019

TCGA-AN-A041-01A-11W-A050-09	BRCA	f18c7389-6c8d-485f-a7f7-a450a42e3719
TCGA-AN-A049-01A-21W-A019-09	BRCA	1d0c87ef-6840-4051-85d5-7fc2c544578c
TCGA-AN-A04A-01A-21W-A050-09	BRCA	7e8f250c-6162-4049-8559-5bfd054b021
TCGA-AN-A04C-01A-21W-A050-09	BRCA	c1302f79-cc50-487a-9db5-016df85e67d7
TCGA-AN-A04D-01A-21W-A050-09	BRCA	9407735f-19e3-49d0-b783-cd9672dfa6a9
TCGA-AN-A0AJ-01A-11W-A019-09	BRCA	97fbce82-0eed-4d70-9af2-57918a4ea8da
TCGA-AN-A0AL-01A-11W-A019-09	BRCA	47849ee3-b59e-4ccf-a261-65f7e252b885
TCGA-AN-A0AM-01A-11W-A050-09	BRCA	a238f21f-ca46-4759-b5b7-f8c3810dfbdb
TCGA-AN-A0AR-01A-11W-A019-09	BRCA	a2d77acd-89db-4d2d-89d7-d1cc58cf576b
TCGA-AN-A0AS-01A-11W-A019-09	BRCA	2257c942-1274-47e7-86ad-b92ecfafc205
TCGA-AN-A0AT-01A-11D-A045-09	BRCA	f848b66f-bd9e-4fba-afd4-eb58848d1ef4
TCGA-AN-A0FD-01A-11W-A050-09	BRCA	abae6f4c-2378-4fbd-adea-f739e6629b22
TCGA-AN-A0FF-01A-11W-A050-09	BRCA	cd45e46c-50bf-449e-bb40-29ccffbbd49c
TCGA-AN-A0FJ-01A-11W-A019-09	BRCA	6b988737-0504-42bb-8c75-d70d7a312e68
TCGA-AN-A0FK-01A-11W-A050-09	BRCA	a765959e-b234-427d-aade-855d6d4981d9
TCGA-AN-A0FL-01A-11W-A050-09	BRCA	18ee29ae-fe36-49a3-9843-e0757c69a7dd
TCGA-AN-A0FN-01A-11W-A050-09	BRCA	8f583981-b257-43ee-9c9e-71a192a49d38
TCGA-AN-A0FS-01A-11W-A050-09	BRCA	9bb76d20-cefb-4f7a-80c2-aa2178e302a9
TCGA-AN-A0FT-01A-11W-A050-09	BRCA	0598fc5f-9651-4ace-bf4e-56759d544e52
TCGA-AN-A0FV-01A-11W-A019-09	BRCA	c70259c1-f561-43d7-9829-6852815baa87
TCGA-AN-A0FW-01A-11W-A050-09	BRCA	5afde43a-194c-4876-b244-2132aef2f505
TCGA-AN-A0FX-01A-11W-A050-09	BRCA	2523cf22-1a16-42be-8560-833ed2031e3c
TCGA-AN-A0FY-01A-11W-A050-09	BRCA	a6a8bd08-0e60-442d-adce-de020177f82c
TCGA-AN-A0FZ-01A-11W-A050-09	BRCA	d77f59f7-8cff-41f3-a1bb-0de14524d4f4
TCGA-AN-A0G0-01A-11W-A050-09	BRCA	9eb55dd2-a956-4dfe-8631-04722c49819f
TCGA-AN-A0XL-01A-11D-A10M-09	BRCA	1b08a181-a73b-4506-aaa3-3521f2c57207
TCGA-AN-A0XN-01A-21D-A10G-09	BRCA	94a6c172-25e2-4438-945c-9b310f89ae22
TCGA-AN-A0XO-01A-11D-A10G-09	BRCA	f63863f5-cb60-4961-a5b4-ed5ea1fb3dc8
TCGA-AN-A0XP-01A-11D-A117-09	BRCA	6179b498-2cea-4f7a-82a8-b7ec71431ea8
TCGA-AN-A0XR-01A-11D-A10G-09	BRCA	e7dc7492-3a84-49c7-8dea-8f508b53dc40
TCGA-AN-A0XS-01A-22D-A10G-09	BRCA	f1b5268d-556f-404f-a956-770df4a1e7aa
TCGA-AN-A0XT-01A-11D-A10G-09	BRCA	353d9161-95fd-4bec-abb7-859d9ee19785
TCGA-AN-A0XU-01A-11D-A10G-09	BRCA	537c5818-eb89-4b46-8915-2bb2b9e4545f
TCGA-AN-A0XV-01A-11D-A10G-09	BRCA	6f0e5a39-e2c7-4a93-bd63-f1bab1e7c16e
TCGA-AN-A0XW-01A-11D-A10G-09	BRCA	200dba9e-201b-4634-a2cf-666e1f6710dc
TCGA-AO-A03L-01A-41W-A071-09	BRCA	743a29c4-e1cc-457a-8406-765f1a1bc114
TCGA-AO-A03N-01B-11D-A10M-09	BRCA	ef5987f1-46ac-430a-b94a-49afa0e286d4
TCGA-AO-A03O-01A-11W-A019-09	BRCA	1578b356-7f42-4722-bc54-cd5f37954f6a
TCGA-AO-A03P-01A-11W-A019-09	BRCA	185c5e15-c068-4a72-8d5e-468624bf958a
TCGA-AO-A03R-01A-21W-A050-09	BRCA	6d2dc4e3-f1ed-4ef0-ae83-e09c87756d56
TCGA-AO-A03T-01A-21W-A050-09	BRCA	cbea866d-da66-4f7c-994b-c1ec35aa2d4b

2019203664 24 May 2019

TCGA-AO-A03U-01B-21D-A10M-09	BRCA	1e0ecd57-5c7d-4495-874d-9e286c999c22
TCGA-AO-A03V-01A-11D-A10Y-09	BRCA	d88c365f-366a-49d5-9860-b930aab3eb1b
TCGA-AO-A0J2-01A-11W-A050-09	BRCA	84b66e02-1b37-4424-b752-363f7861fe74
TCGA-AO-A0J3-01A-11W-A050-09	BRCA	ff706355-867e-4968-99ad-0af4e24ece51
TCGA-AO-A0J4-01A-11W-A050-09	BRCA	7667f49c-449d-44ce-bab8-02a491bb6775
TCGA-AO-A0J5-01A-11W-A050-09	BRCA	93ae73f6-c355-47be-a355-faa78c0632d4
TCGA-AO-A0J6-01A-11W-A050-09	BRCA	7d21a0c4-03c7-4641-8b4d-7a5877960360
TCGA-AO-A0J7-01A-11W-A050-09	BRCA	a53056d9-e8bd-4cb1-ad67-85879ccc925d
TCGA-AO-A0J8-01A-21D-A045-09	BRCA	24ba5501-8097-4af6-b12c-bb6dcbe10cac
TCGA-AO-A0J9-01A-11W-A050-09	BRCA	9932232f-a7b0-4962-9b14-adb8316a4661
TCGA-AO-A0JA-01A-11W-A071-09	BRCA	0215d4f1-6697-4e8f-afc4-ff7c6439e56d
TCGA-AO-A0JB-01A-11W-A071-09	BRCA	8f4f06be-2a16-4ae2-9dd4-5d87f480810b
TCGA-AO-A0JC-01A-11W-A071-09	BRCA	120f55df-5d1d-4073-a21a-632c892d3da9
TCGA-AO-A0JD-01A-11W-A071-09	BRCA	9d3ad8d0-ddd3-44d2-ba0e-0b283a4fbf32
TCGA-AO-A0JE-01A-11W-A071-09	BRCA	4f311714-ebb4-47fb-b471-62c6951d9066
TCGA-AO-A0JF-01A-11W-A071-09	BRCA	191caa1a-5ab8-4db5-b42a-f1c5964b0b0d
TCGA-AO-A0JG-01A-31D-A099-09	BRCA	cf7ec093-5040-43db-949c-f426795a7488
TCGA-AO-A0JL-01A-21W-A100-09	BRCA	861297ec-2c88-4717-ae63-eb8e21fe8c52
TCGA-AO-A0JJ-01A-11W-A071-09	BRCA	812191d1-6711-4efd-8932-c76159b60ffb
TCGA-AO-A0JL-01A-11W-A071-09	BRCA	56a22648-be92-402c-a225-bcaa44a7e612
TCGA-AO-A0JM-01A-21W-A071-09	BRCA	f070142b-f44e-4264-8919-dde7d02ad835
TCGA-AO-A124-01A-11D-A10M-09	BRCA	987528ac-437a-4eb8-a335-4f2076d5c006
TCGA-AO-A125-01A-11D-A10M-09	BRCA	17669c6d-2eeb-4d56-ac72-f06bfafb7e42
TCGA-AO-A126-01A-11D-A10M-09	BRCA	85b39644-6f19-40dc-94c1-0afc93ee4981
TCGA-AO-A129-01A-21D-A10M-09	BRCA	cdf43c25-3ba7-4073-a92d-4a97f651f4a8
TCGA-AO-A12A-01A-21D-A10Y-09	BRCA	77e7b41a-d4c8-42ee-ae6e-da15ea3634d9
TCGA-AO-A12B-01A-11D-A10M-09	BRCA	865ebd77-7b7d-4a27-b945-df5ec8d1f86a
TCGA-AO-A12D-01A-11D-A10Y-09	BRCA	b3065cfe-3067-4f08-8c82-46f10c1ec279
TCGA-AO-A12E-01A-11D-A10M-09	BRCA	b3990b59-e2f4-4759-8eb0-11ad3c34ac50
TCGA-AO-A12F-01A-11D-A10Y-09	BRCA	d1617673-57c2-40c1-a970-f3692ee13cf3
TCGA-AO-A12G-01A-11D-A10M-09	BRCA	5b9d3741-2aa3-489b-93e6-3b5376b80d48
TCGA-AO-A12H-01A-11D-A10Y-09	BRCA	5a535c49-d42e-43c6-9d32-dc76f28d4f0f
TCGA-AO-A1KO-01A-31D-A188-09	BRCA	2cdech2b-40b1-4419-bcd9-101cee78966c
TCGA-AO-A1KP-01A-11D-A13L-09	BRCA	bc36db60-3f6b-42c4-b03e-b7c74c3dda5c
TCGA-AO-A1KR-01A-12D-A142-09	BRCA	d3b598d8-8a3b-4506-aa98-9fbc5b51afd4
TCGA-AO-A1KS-01A-11D-A13L-09	BRCA	21074661-4b0f-4adc-b406-5801688a3ae9
TCGA-AO-A1KT-01A-11D-A13L-09	BRCA	97b33dc3-6a62-419a-aa6c-cb84c9f92102
TCGA-AQ-A04H-01B-11D-A10M-09	BRCA	73c13e04-1400-4ebb-aa80-f54becbe036c
TCGA-AQ-A04J-01A-02W-A050-09	BRCA	cce21f2b-784b-4fa0-9809-ae532c528f8e
TCGA-AQ-A04L-01B-21D-A10M-09	BRCA	e8d7feb0-981b-4ba0-b4d4-fa985064444b
TCGA-AQ-A0Y5-01A-11D-A14K-09	BRCA	4aa80fbd-a337-49b6-9371-223cbcfbc85d

2019203664 24 May 2019

TCGA-AQ-A1H2-01A-11D-A13L-09	BRCA	1ab2dc63-51ce-4a96-b7ad-f0d9eb198d10
TCGA-AQ-A1H3-01A-31D-A13L-09	BRCA	1fa2017e-ce08-4a16-bdf6-f9bf1296c834
TCGA-AR-A0TP-01A-11D-A099-09	BRCA	bee5b9c8-739e-4530-b140-cd2b898d7afd
TCGA-AR-A0TQ-01A-11D-A099-09	BRCA	b266fffc-263d-4b0f-a781-7437e41061b2
TCGA-AR-A0TR-01A-11D-A099-09	BRCA	58ca11bf-17b0-4cff-b210-5b85d8e66ef5
TCGA-AR-A0TS-01A-11D-A10Y-09	BRCA	c9253ecc-cfac-4cc5-8dab-1e502d34d103
TCGA-AR-A0TT-01A-31D-A099-09	BRCA	29cfdc11-2f20-436e-8913-340909684c06
TCGA-AR-A0TU-01A-31D-A10G-09	BRCA	31922dbe-3b4a-4ac1-98fc-db88ae851462
TCGA-AR-A0TV-01A-21D-A099-09	BRCA	0ec80200-12fe-479c-8ea0-982a9995f55a
TCGA-AR-A0TW-01A-11D-A099-09	BRCA	b40d49ed-bc30-4656-9f36-ffc280de2fb8
TCGA-AR-A0TX-01A-11D-A099-09	BRCA	63d635fa-d136-4e8a-a534-966ee678bb66
TCGA-AR-A0TY-01A-12W-A12T-09	BRCA	f915733b-aaf4-406d-af52-00de113e8e0c
TCGA-AR-A0TZ-01A-12D-A099-09	BRCA	90a26d5e-356b-424c-80bc-4723d24c594f
TCGA-AR-A0U0-01A-11D-A10G-09	BRCA	79e2c073-7727-4c34-ac28-5d7895144743
TCGA-AR-A0U1-01A-11D-A10Y-09	BRCA	265ceec6-e9a8-499e-adf6-0c18c598532e
TCGA-AR-A0U2-01A-11D-A10G-09	BRCA	f0194733-2347-43c4-a4a3-131642c27798
TCGA-AR-A0U3-01A-11D-A10G-09	BRCA	c8251555-77d3-4a20-9cc0-f7df0fda5955
TCGA-AR-A0U4-01A-11D-A117-09	BRCA	ed064e31-8fae-4f9c-8455-d7517f94e16b
TCGA-AR-A1AH-01A-11D-A12B-09	BRCA	ff4a0f5a-9f30-4a2b-9915-62f2df5ad155
TCGA-AR-A1AI-01A-11D-A12Q-09	BRCA	842846ea-881c-4d79-88d2-fc1703c58350
TCGA-AR-A1AJ-01A-21D-A12Q-09	BRCA	4e1f9084-4729-4b3f-b036-6226d64fd25b
TCGA-AR-A1AK-01A-21D-A12Q-09	BRCA	52f7c22f-84cb-4263-93bf-1ae8cf8abbd2
TCGA-AR-A1AL-01A-21D-A12Q-09	BRCA	8495c66e-dc95-4eae-909b-b51b8bc84889
TCGA-AR-A1AN-01A-11D-A12Q-09	BRCA	9c879ced-92e8-4292-9b24-46005acab0f4
TCGA-AR-A1AO-01A-11D-A12Q-09	BRCA	b841db95-2eff-4181-8d44-3cde2f2f9e70
TCGA-AR-A1AP-01A-11D-A12Q-09	BRCA	597e37c9-f0c9-4839-800e-6e9519ec3add
TCGA-AR-A1AQ-01A-11D-A12Q-09	BRCA	88ff7728-ecc9-4ec5-817e-4793619ab5a4
TCGA-AR-A1AR-01A-31D-A135-09	BRCA	008ba655-a0a3-42c4-8c72-f1341365ef02
TCGA-AR-A1AS-01A-11D-A12Q-09	BRCA	3f26f93c-e11a-4ec9-b73b-98fcadc209f4
TCGA-AR-A1AT-01A-11D-A12Q-09	BRCA	7e00d4fa-b951-44d8-8fbf-fc7b9f19772e
TCGA-AR-A1AU-01A-11D-A12Q-09	BRCA	d7cfeb04-ce20-4aab-8e5b-8a1483bcaaa5
TCGA-AR-A1AV-01A-21D-A12Q-09	BRCA	0a0dd89c-5ec8-4015-9616-733e41361a64
TCGA-AR-A1AW-01A-21D-A12Q-09	BRCA	33c6b6b5-1484-4002-8f84-ba67525a8777
TCGA-AR-A1AX-01A-11D-A12Q-09	BRCA	71a3cf72-3539-4ade-97d1-6a1bd1ee4205
TCGA-AR-A1AY-01A-21D-A12Q-09	BRCA	15f90ef0-831b-40a3-98bd-ec226a9e8b26
TCGA-AR-A24H-01A-11D-A167-09	BRCA	6bb61dce-289d-4e39-8298-df5abe8049a2
TCGA-AR-A24K-01A-11D-A167-09	BRCA	df692383-1d6d-4caa-b44c-7a133ec4b7ee
TCGA-AR-A24L-01A-11D-A167-09	BRCA	2a93298a-d272-487c-ae4a-ec385844536e
TCGA-AR-A24M-01A-11D-A167-09	BRCA	722a8960-3a69-4f66-b972-74e6de94a1e8
TCGA-AR-A24N-01A-11D-A167-09	BRCA	b85b311c-1b29-44e3-8585-6995f9259221
TCGA-AR-A24O-01A-11D-A167-09	BRCA	2c9fc77f-951b-4764-911a-f0cff3174fb1

2019203664 24 May 2019

TCGA-AR-A24P-01A-11D-A167-09	BRCA	dbdcf82a-3d37-4cfb-a70b-9b69ada0e732
TCGA-AR-A24Q-01A-12D-A167-09	BRCA	a9d691f2-ad2a-4a3b-ae30-ed4af96d75f2
TCGA-AR-A24R-01A-11D-A167-09	BRCA	baf43433-0001-4495-a37f-9132eb213157
TCGA-AR-A24S-01A-11D-A167-09	BRCA	aad32a56-5b98-433e-bb6e-48e09a027db6
TCGA-AR-A24T-01A-11D-A167-09	BRCA	09991de6-2e8e-476f-987b-98d9a85dac7d
TCGA-AR-A24U-01A-11D-A167-09	BRCA	567cdc6c-df03-4642-8cbc-a269769ce1a1
TCGA-AR-A24V-01A-21D-A167-09	BRCA	bb77af66-bb8f-4590-9be8-5f729373c555
TCGA-AR-A24W-01A-11D-A17G-09	BRCA	454e7cd4-8424-4cad-8fbb-f69affa5d1bf
TCGA-AR-A24X-01A-11D-A167-09	BRCA	53d55f5a-df86-44d7-a3a2-2dccc2557b7b
TCGA-AR-A24Z-01A-11D-A167-09	BRCA	c11f2060-d3fb-4e3d-8058-b8cce44af519
TCGA-AR-A250-01A-31D-A167-09	BRCA	f7d9a372-fcd1-4462-9e0b-7eb46ddb68fd
TCGA-AR-A251-01A-12D-A167-09	BRCA	68b4de6d-352d-44e8-911a-f4541f28fc78
TCGA-AR-A252-01A-11D-A167-09	BRCA	e800d9b3-32a1-48eb-840b-9a3bec9d1f6e
TCGA-AR-A254-01A-21D-A167-09	BRCA	fe2bdac0-832e-4268-bd8f-5dcfffd1979
TCGA-AR-A255-01A-11D-A167-09	BRCA	505f1398-0bd8-4f1c-a142-651605158bf3
TCGA-AR-A256-01A-11D-A167-09	BRCA	ea43434b-197e-48ac-ae2e-46bc7f3776de
TCGA-B6-A0I2-01A-11W-A050-09	BRCA	a9cae7c8-a62b-46ad-a98b-82e6b5fddf00
TCGA-B6-A0I5-01A-11W-A100-09	BRCA	f1139266-fade-4d27-ac67-60870e666295
TCGA-B6-A0I6-01A-11D-A128-09	BRCA	a876398c-5b1d-444f-a360-5fe2db697480
TCGA-B6-A0I8-01A-11W-A050-09	BRCA	ba80b13a-e20a-441b-b845-b617cc861ce7
TCGA-B6-A0I9-01A-11W-A050-09	BRCA	d2291482-9bbb-4f8f-a65b-c0737cf3acea
TCGA-B6-A0IA-01A-11W-A050-09	BRCA	f7e5ada6-8f53-4765-a874-5ee9d258ad6a
TCGA-B6-A0IB-01A-11W-A050-09	BRCA	ff80d5cd-7aed-499f-a472-153cc40f65de
TCGA-B6-A0IC-01A-11W-A050-09	BRCA	f23fd730-0a18-4e3b-a2ed-f1a4231c2b53
TCGA-B6-A0IE-01A-11W-A050-09	BRCA	4cb39f50-5031-4b08-baa3-1a366ada6514
TCGA-B6-A0IG-01A-11W-A050-09	BRCA	e8046519-d928-4fd3-b3e2-84585aa4f022
TCGA-B6-A0IH-01A-11D-A10Y-09	BRCA	4a4488b9-74d9-4eb1-a7ef-c894c32db942
TCGA-B6-A0IJ-01A-11W-A050-09	BRCA	c63f9ddb-6301-400e-a0e8-197eea2efe75
TCGA-B6-A0IK-01A-12W-A071-09	BRCA	c5b1f426-562e-44e4-bcce-ce2ff6d969c8
TCGA-B6-A0IM-01A-11W-A050-09	BRCA	e99a4753-10db-4823-953d-e878a90e6b01
TCGA-B6-A0IN-01A-11W-A050-09	BRCA	ee2c9198-cea3-4a54-b96b-834a70c30d2f
TCGA-B6-A0IO-01A-11W-A050-09	BRCA	648cee86-f2e7-45a0-abf2-0ab0037e2eee
TCGA-B6-A0IP-01A-11D-A045-09	BRCA	94250f1c-d514-4dd2-b488-a93fbf111784
TCGA-B6-A0IQ-01A-11W-A050-09	BRCA	583964cf-84ad-4ef1-90d1-2f6fbfbeb245a
TCGA-B6-A0RE-01A-11W-A071-09	BRCA	db2bd5cf-f0a7-4874-89eb-15029447dae1
TCGA-B6-A0RG-01A-11W-A071-09	BRCA	9431c642-610e-4325-97b8-8b4c5c81cadd
TCGA-B6-A0RH-01A-21D-A10Y-09	BRCA	6e59b987-b4f0-4078-af2d-482c299103b6
TCGA-B6-A0RI-01A-11W-A071-09	BRCA	50d83050-b98c-4a1a-a673-91dbc67c37c6
TCGA-B6-A0RL-01A-11D-A099-09	BRCA	0d28966d-e03b-4b2a-ba07-b8f195efc29b
TCGA-B6-A0RM-01A-11D-A099-09	BRCA	3e03385e-f0fa-4e11-8bed-c6316802e1a9
TCGA-B6-A0RN-01A-12D-A099-09	BRCA	bbbc493-2937-4a7b-8454-0abbbb379927

2019203664 24 May 2019

TCGA-B6-A0RO-01A-22D-A099-09	BRCA	05e12ff8-023b-4ac1-b35d-f97b42e3da7a
TCGA-B6-A0RP-01A-21D-A099-09	BRCA	efbdb449-b885-44bb-9054-9e97d6603cad
TCGA-B6-A0RQ-01A-11D-A10Y-09	BRCA	f425edf3-0d08-49bf-94f6-f03343873a6c
TCGA-B6-A0RS-01A-11D-A099-09	BRCA	6b3ff733-402d-4390-8f57-57a9ad9b9969
TCGA-B6-A0RT-01A-21D-A099-09	BRCA	e1a297ed-1951-4d97-978c-56b452111ba5
TCGA-B6-A0RU-01A-11D-A099-09	BRCA	251371ac-ef46-4e11-b45e-a2aaa986a2d2
TCGA-B6-A0RV-01A-11D-A099-09	BRCA	39b0b605-29ae-4e2c-81dc-319446c807dd
TCGA-B6-A0WS-01A-11D-A10Y-09	BRCA	271d1985-1b15-4828-8261-4415ab048de9
TCGA-B6-A0WT-01A-11D-A10G-09	BRCA	5fb780fb-12bc-4195-8f0c-2c6e3cc36b49
TCGA-B6-A0WV-01A-11D-A10G-09	BRCA	b92107c5-c46f-4606-b4e9-2dab55ca4e9c
TCGA-B6-A0WW-01A-11D-A10G-09	BRCA	e9d6f59d-7d87-4fda-ab6f-e9c2501b8600
TCGA-B6-A0WX-01A-11D-A10G-09	BRCA	47b5d831-5287-4f62-b17a-6e5eff2e4184
TCGA-B6-A0WY-01A-11D-A10G-09	BRCA	c973a902-abdf-41a3-8250-57011dfef1f4
TCGA-B6-A0WZ-01A-11D-A10G-09	BRCA	f6b8b1a9-370c-4023-b8bd-934e2a3d913a
TCGA-B6-A0X0-01A-21D-A10Y-09	BRCA	264fb6ef-65be-48fd-8216-6c493b620ad8
TCGA-B6-A0X1-01A-11D-A10G-09	BRCA	a492abf9-0cd3-402c-89e2-c49d650ef540
TCGA-B6-A0X4-01A-11D-A10G-09	BRCA	edbe95af-e727-4d0f-a2a4-a3c9f2afa901
TCGA-B6-A0X5-01A-21D-A10G-09	BRCA	da42f10b-d515-4678-a038-ed9c92a8b56b
TCGA-B6-A0X7-01A-11D-A10M-09	BRCA	be5f93af-844a-4adb-ad89-05bfeefa58cd
TCGA-B6-A1KC-01B-11D-A159-09	BRCA	fc3e822f-150d-47a7-a346-10919b42aa8c
TCGA-B6-A1KF-01A-11D-A13L-09	BRCA	fbfbc76-0524-4772-b918-1e8599a09d7f
TCGA-B6-A1KI-01A-11D-A14K-09	BRCA	d9374702-8fc6-48c0-bec5-5c1105e641dc
TCGA-B6-A1KN-01A-11D-A13L-09	BRCA	c1ad09c8-4237-48f0-b04c-7ee8ccaf8cf1
TCGA-BH-A0AU-01A-11D-A12Q-09	BRCA	d06209b8-8aba-44d8-b94a-990861c2324a
TCGA-BH-A0AV-01A-31D-A10Y-09	BRCA	9032b7fe-e38a-4641-a45e-67041668adc4
TCGA-BH-A0AW-01A-11W-A071-09	BRCA	82057159-dd32-49fd-9ee7-82b4668f39c3
TCGA-BH-A0AZ-01A-21D-A12Q-09	BRCA	e6d90bb8-ad96-4cb8-a96f-a8202fcbc58f
TCGA-BH-A0B0-01A-21D-A10Y-09	BRCA	4680fd93-33c8-4aee-942b-5c616acd02cf
TCGA-BH-A0B1-01A-12W-A071-09	BRCA	de20290a-1560-41fd-896b-a3ae1103423e
TCGA-BH-A0B4-01A-11W-A019-09	BRCA	83bee702-eb97-4216-a47e-d4e4eece279a
TCGA-BH-A0B5-01A-11D-A12Q-09	BRCA	dfa0f8ea-ae94-4673-9751-f6cdad26022a
TCGA-BH-A0B9-01A-11W-A071-09	BRCA	c57595bb-7953-4611-b0d1-3c2c40feb3b9
TCGA-BH-A0BD-01A-11W-A050-09	BRCA	eba2178f-6235-49c1-a49e-98de8ffdc6a0
TCGA-BH-A0BF-01A-21D-A12Q-09	BRCA	39221056-704b-4a23-9b8d-3178dd9e790d
TCGA-BH-A0BG-01A-11D-A10Y-09	BRCA	923ee16a-2c42-46ee-b2cb-82075f2dd603
TCGA-BH-A0BP-01A-11D-A10Y-09	BRCA	51405cf1-e844-4316-be17-85e8ad1de4a3
TCGA-BH-A0BR-01A-21W-A12T-09	BRCA	df82226e-2242-418b-9f5f-0a5e531826a4
TCGA-BH-A0BS-01A-11D-A12Q-09	BRCA	81e4b7a4-8d94-4d31-9c08-325ee04f5f36
TCGA-BH-A0BT-01A-11D-A12Q-09	BRCA	2299036e-7099-4b53-9143-5935442c3310
TCGA-BH-A0BZ-01A-31D-A12Q-09	BRCA	1f07765a-3f2b-4b6f-88ef-0d7aab17a758
TCGA-BH-A0C1-01B-11D-A12B-09	BRCA	adebc709-8059-43c3-ad0e-a102fa1536ff

2019203664 24 May 2019

TCGA-BH-A0C3-01A-21D-A12Q-09	BRCA	ec57ee0f-949e-4eee-91c2-dd129d657065
TCGA-BH-A0C7-01B-11D-A10Y-09	BRCA	ba3b30c5-8179-49bd-aacd-53326bf356f8
TCGA-BH-A0DD-01A-31D-A12Q-09	BRCA	1a59cd97-2ee8-4f82-b542-e2f35171bc01
TCGA-BH-A0DG-01A-21D-A12Q-09	BRCA	ec4d4cbc-d5d1-418d-a292-cad9576624fd
TCGA-BH-A0DI-01A-21D-A12Q-09	BRCA	3777748c-5614-4826-8cde-eb7ecef8101
TCGA-BH-A0DO-01B-11D-A12B-09	BRCA	14649437-79a6-40bd-87b1-a278bf2dcda
TCGA-BH-A0DS-01A-11W-A071-09	BRCA	6cfb5de9-ef59-4bc0-9ec2-f9bd5a9f2aee
TCGA-BH-A0DT-01A-21D-A12B-09	BRCA	30dbe353-86d5-40ed-84c2-dbdd77beb17b
TCGA-BH-A0DV-01A-21D-A12Q-09	BRCA	24ee6b1d-3594-4d12-91b3-8ad1b3c98f28
TCGA-BH-A0DX-01A-11D-A10Y-09	BRCA	bca403d9-48ff-4534-ba33-94b8fb9fee0f
TCGA-BH-A0E2-01A-11W-A071-09	BRCA	2703ce22-3ffa-4094-b3f1-1f573b5204a9
TCGA-BH-A0E6-01A-11W-A050-09	BRCA	1c55939a-ae58-4ed9-8a6e-01bae8ac12f7
TCGA-BH-A0E7-01A-11W-A050-09	BRCA	1ddc3a98-e0b9-4b8e-b3d3-9d39eb7d8264
TCGA-BH-A0E9-01B-11D-A10Y-09	BRCA	48ccd30d-0c71-4117-8ccb-013986f14e95
TCGA-BH-A0EA-01A-11D-A10Y-09	BRCA	561b8777-801a-49ed-a306-e7dafeb044b6
TCGA-BH-A0EB-01A-11W-A050-09	BRCA	3861ca01-bcc3-42a9-835d-1ef9f1a053bd
TCGA-BH-A0EE-01A-11W-A050-09	BRCA	68d16e6a-20a5-428f-89d0-a8a0deda80cc
TCGA-BH-A0EI-01A-11D-A10Y-09	BRCA	ee8e93e0-d08c-400e-8ed7-ae56d7aefbec
TCGA-BH-A0GY-01A-11W-A071-09	BRCA	db589949-1630-45b2-b09b-0312d3efd60b
TCGA-BH-A0GZ-01A-11W-A071-09	BRCA	068bd892-6fee-46c2-945f-34a6c6804070
TCGA-BH-A0H0-01A-11W-A071-09	BRCA	69110467-4cf5-4b5d-a2dd-b1c91e786959
TCGA-BH-A0H3-01A-11D-A12Q-09	BRCA	12d7de75-2e4f-42f6-a067-fe6d7118a0b6
TCGA-BH-A0H6-01A-21W-A071-09	BRCA	bbed00d2-9791-464d-a1ba-28fd56a0504e
TCGA-BH-A0HA-01A-11D-A12Q-09	BRCA	95f2ee35-a485-4995-8205-01623d97da2d
TCGA-BH-A0HB-01A-11W-A071-09	BRCA	ed5f1077-62c1-43d8-8a27-56521bbdd8a5
TCGA-BH-A0HI-01A-11D-A099-09	BRCA	507213d0-ef1c-400c-8724-24cd6a39feb8
TCGA-BH-A0HL-01A-11W-A050-09	BRCA	1fd1db26-79e0-4018-8548-8fd20a96c479
TCGA-BH-A0HN-01A-11D-A099-09	BRCA	ada199c5-8015-481f-a46e-46fa42646cd8
TCGA-BH-A0HO-01A-11W-A050-09	BRCA	354172e7-3e54-4ec4-88fa-fd7781cc86ae
TCGA-BH-A0HP-01A-12D-A099-09	BRCA	ad52a8fb-7a76-4aa0-95fb-d6edab0fe2b2
TCGA-BH-A0HQ-01A-11W-A050-09	BRCA	f03af67f-3119-4ee4-a4b0-227d36f493ba
TCGA-BH-A0HU-01A-11W-A050-09	BRCA	b46f2619-5937-4847-bb38-fe6022225ab9
TCGA-BH-A0HW-01A-11W-A050-09	BRCA	706ec3be-bd65-4f42-b5cc-603f7f62c91a
TCGA-BH-A0HX-01A-21W-A071-09	BRCA	27df78cd-1f39-42f3-92e6-56664d4c472c
TCGA-BH-A0HY-01A-11W-A071-09	BRCA	a63c2000-9e41-4897-8b01-4723c382096e
TCGA-BH-A0RX-01A-21D-A099-09	BRCA	48115e9a-5027-455a-a88e-c3d991dbf966
TCGA-BH-A0W3-01A-11D-A10G-09	BRCA	3fa14183-e0c5-4dc2-bb4a-d8dd42f6578b
TCGA-BH-A0W4-01A-11D-A10G-09	BRCA	fdafddde-aff1-42b4-bf94-a95861eac5f3
TCGA-BH-A0W5-01A-11D-A10G-09	BRCA	aca1d737-c24c-49fd-86c0-ab2b29cd28de
TCGA-BH-A0W7-01A-11D-A10Y-09	BRCA	7d20774c-6aac-4eb0-a876-1be14e0f3004
TCGA-BH-A0WA-01A-11D-A10G-09	BRCA	4076f947-a1f0-4101-9a79-79828eb3bbe3

2019203664 24 May 2019

TCGA-BH-A18F-01A-11D-A12B-09	BRCA	d414b3fe-b768-4a98-b285-5284bffa66f9
TCGA-BH-A18H-01A-11D-A12B-09	BRCA	d3c1b990-aae2-45f8-be28-8ccd192a0fab
TCGA-BH-A18I-01A-11D-A12B-09	BRCA	f0ca4831-d56d-4bae-b304-bb43c5d2f09b
TCGA-BH-A18J-01A-11D-A12B-09	BRCA	fd9923db-2a27-432e-a0c6-4c44e6ee1f53
TCGA-BH-A18K-01A-11D-A12B-09	BRCA	f75de986-bc8a-4ffe-9b35-011eeec3a1446
TCGA-BH-A18L-01A-32D-A12B-09	BRCA	883cd3c9-2681-4822-8b22-29149a027514
TCGA-BH-A18M-01A-11D-A12B-09	BRCA	0e548c1e-cbb7-4432-8112-bb262a1ef9d9
TCGA-BH-A18N-01A-11D-A12B-09	BRCA	13c38ac4-c410-4602-83e3-9b80b4f93839
TCGA-BH-A18P-01A-11D-A12B-09	BRCA	add624a3-57e9-46be-9bcc-3e53d7c2dfb7
TCGA-BH-A18Q-01A-12D-A12B-09	BRCA	a4de6680-33c3-4f6f-8696-453470a00bcb
TCGA-BH-A18R-01A-11D-A12B-09	BRCA	42facac2-81d9-4a9f-b4f6-1de89a7662fc
TCGA-BH-A18S-01A-11D-A12B-09	BRCA	a01c12fc-a33e-4a06-8b69-ebe6d4f59c2b
TCGA-BH-A18T-01A-11D-A12B-09	BRCA	4e0ddfc8-e847-4132-bdce-aaec2e027b28
TCGA-BH-A18U-01A-21D-A12B-09	BRCA	a8400863-c145-4c6c-bcf3-e4cc4d816d22
TCGA-BH-A18V-01A-11D-A12B-09	BRCA	6150dd25-a8f4-4d9f-9da0-f956855ab67d
TCGA-BH-A18W-01A-11D-A17G-09	BRCA	ca100ef0-be45-415f-909d-7172261d0084
TCGA-BH-A18X-01A-11D-A135-09	BRCA	20131381-8a11-425d-8954-980e6ec7c427
TCGA-BH-A18Y-01A-11D-A135-09	BRCA	7ecda44b-e942-4077-9d18-2a844ec53c9d
TCGA-BH-A18Z-01A-11D-A135-09	BRCA	9bd66613-68ad-42c1-ab43-dac1386027f9
TCGA-BH-A19A-01A-11D-A135-09	BRCA	dc578e75-e63c-4bdf-abfa-e2d063c9cd6d
TCGA-BH-A19B-01A-11D-A135-09	BRCA	43fbe2a9-078a-4be2-b67c-b855329091f0
TCGA-BH-A19C-01A-11D-A135-09	BRCA	c6f4b1b6-a8dd-4a9a-a500-b14a738fe18f
TCGA-BH-A19D-01A-11D-A13L-09	BRCA	537b1685-0882-48ee-a38a-a05b5d1c8ba1
TCGA-BH-A19E-01A-11D-A13L-09	BRCA	7c035023-8ea9-4504-8f03-9573745cb6ef
TCGA-BH-A19F-01A-11D-A135-09	BRCA	3903b485-366d-4318-b17d-a0194f032bd8
TCGA-BH-A19G-01A-31D-A13L-09	BRCA	a5c67494-d843-4b14-ba9c-d077396ed2dc
TCGA-BH-A19H-01A-12D-A13L-09	BRCA	82121518-98d6-4db6-8be4-74bbe232a9ed
TCGA-BH-A19I-01A-11D-A13L-09	BRCA	34eb095d-3d44-4c59-9ef5-94592ba97900
TCGA-BH-A19J-01A-11D-A13L-09	BRCA	030cfc8a-7b43-4d73-8bfa-b68a47749e49
TCGA-BH-A19K-01A-11D-A13L-09	BRCA	84c77098-03d0-4b22-afb1-797703e85c6c
TCGA-BH-A19L-01A-11W-A14Q-09	BRCA	b372b5cd-4c38-4cd3-95e0-8708ce5437e7
TCGA-BH-A19M-01A-11D-A13L-09	BRCA	5e71fc3a-a2f4-4899-9c1f-8fee1ef29e2e
TCGA-BH-A19N-01A-11D-A13L-09	BRCA	311f2f1a-75c8-4fee-b31d-0815d71a3173
TCGA-BH-A19O-01A-12D-A13L-09	BRCA	fd6bd486-6371-4892-863e-64838fcea624
TCGA-BH-A19P-01A-11D-A13L-09	BRCA	dc62eafd-b5ad-42b4-9665-11ba6b22cff5
TCGA-BH-A19Q-01A-11D-A13L-09	BRCA	bb84cbb1-7244-4d92-8977-a37dbafc47b4
TCGA-BH-A19R-01A-11D-A13L-09	BRCA	7cb17736-03da-4f77-8397-145585a25b1e
TCGA-BH-A19S-01A-11D-A13L-09	BRCA	bf92d76e-31ff-4273-82ea-982c4c26394b
TCGA-BH-A19T-01A-11D-A13L-09	BRCA	a589f5ac-105c-45d6-96e1-55e3080f999c
TCGA-BH-A19U-01A-11D-A14G-09	BRCA	9efd4bfb-d4e4-487e-8d1c-a19c2d62e3cf
TCGA-BH-A201-01A-11D-A14K-09	BRCA	df6e619f-67a5-49f3-9768-4826aa2c9d1b



2019203664 24 May 2019

TCGA-BH-A202-01A-11D-A14K-09	BRCA	e6feb69a-8827-4d43-94aa-036cf5150549
TCGA-BH-A203-01A-12D-A167-09	BRCA	128b9209-2201-428c-87e7-65690bfe3875
TCGA-BH-A204-01A-11D-A159-09	BRCA	2454d30f-1ca5-4f01-bfce-6ae10e84e75a
TCGA-BH-A208-01A-11D-A159-09	BRCA	ae749fbb-6de7-4c51-b9d6-80a2ce7b5a29
TCGA-BH-A209-01A-11D-A17G-09	BRCA	4eaf8116-4733-4865-8e22-5d03887bbc9b
TCGA-BH-A28Q-01A-11D-A16D-09	BRCA	0698379c-8f4e-460d-b7da-d3f6179dafd7
TCGA-C8-A12K-01A-21D-A10Y-09	BRCA	bcf92c27-3aa7-4449-9c7a-fc715789788f
TCGA-C8-A12L-01A-11D-A10Y-09	BRCA	998a465a-d084-4d7f-8c02-8c5be1e1ee27
TCGA-C8-A12M-01A-11D-A135-09	BRCA	9a0a7b93-da6e-45b7-9a6f-190d79552b49
TCGA-C8-A12N-01A-11D-A10Y-09	BRCA	e2af7f0c-3cf4-4ffe-b764-b4fd83bf7694
TCGA-C8-A12O-01A-11D-A10Y-09	BRCA	51dbda2a-106b-4597-aa49-609b677866c8
TCGA-C8-A12P-01A-11D-A10Y-09	BRCA	540fe594-0186-40d3-b519-c1ccebe82247
TCGA-C8-A12Q-01A-11D-A10Y-09	BRCA	b6b4af38-7ebb-4fa8-9876-6d88d2b1e7e4
TCGA-C8-A12T-01A-11D-A10Y-09	BRCA	961fae8a-d944-4866-b198-ea6f1e59a979
TCGA-C8-A12U-01A-11D-A10Y-09	BRCA	444a1ef9-819a-41dc-baef-22057225efcd
TCGA-C8-A12V-01A-11D-A10Y-09	BRCA	b8728982-8254-4aa8-baa5-aaeb6d852260
TCGA-C8-A12W-01A-11D-A10Y-09	BRCA	5fb924d9-3201-491b-90b1-fe8a6320b2d7
TCGA-C8-A12X-01A-11D-A10Y-09	BRCA	f133a2e3-73a2-40b8-855f-e819e4d11630
TCGA-C8-A12Y-01A-11D-A12B-09	BRCA	d5c0a1a0-3d38-497b-9f47-107f06659cb1
TCGA-C8-A12Z-01A-11D-A10Y-09	BRCA	ae68cac5-e561-4094-98fa-2303cdaa6dbb
TCGA-C8-A130-01A-31D-A10Y-09	BRCA	da70101d-10c2-47ab-bce1-7757dcb08a2
TCGA-C8-A131-01A-11D-A10Y-09	BRCA	df8c72f3-ca4f-4a15-8d58-976d9c796570
TCGA-C8-A132-01A-31D-A10Y-09	BRCA	c038ab30-af2f-4771-bf82-dcf19f32efab
TCGA-C8-A133-01A-32D-A12B-09	BRCA	641e848d-e3e2-46a7-ad42-5e5672639816
TCGA-C8-A134-01A-11D-A10Y-09	BRCA	a3e8738b-2456-4f08-bb3d-5debb4265f85
TCGA-C8-A135-01A-11D-A10Y-09	BRCA	6b47c22f-8b4e-40fd-9a12-18b539521224
TCGA-C8-A137-01A-11D-A10Y-09	BRCA	08778f40-d895-46f1-8e7b-122fc598418b
TCGA-C8-A138-01A-11D-A10Y-09	BRCA	f3474e56-8457-4f0b-8a2f-58fdd8f58607
TCGA-C8-A1HE-01A-11D-A188-09	BRCA	8314bada-5bd3-4cd2-b308-4cb2db64de94
TCGA-C8-A1HF-01A-11D-A135-09	BRCA	508a26f2-d117-44aa-b579-00a119b8bcc4
TCGA-C8-A1HG-01A-11D-A135-09	BRCA	ba937e3d-30b7-4446-84fb-5f77831a4843
TCGA-C8-A1HI-01A-11D-A135-09	BRCA	75dc3bff-75da-4734-b930-a18fd3d1ebfe
TCGA-C8-A1HJ-01A-11D-A13L-09	BRCA	a62c3601-b90f-402f-8212-ffdfde3c6df8
TCGA-C8-A1HK-01A-21D-A13L-09	BRCA	357e0b08-fa33-4f58-92b0-d7293b63c01d
TCGA-C8-A1HL-01A-11D-A135-09	BRCA	88c9ef88-5d85-4a4b-9c68-d9ec709a1f07
TCGA-C8-A1HM-01A-12D-A135-09	BRCA	a2f9165d-9fe7-492e-9b4c-3cb4200c6e85
TCGA-C8-A1HN-01A-11D-A135-09	BRCA	a2576147-28eb-460f-9b97-916892d801e2
TCGA-C8-A1HO-01A-11D-A13L-09	BRCA	c6fb921c-78fe-4852-b2a5-edd5a02ae923
TCGA-C8-A26V-01A-11D-A16D-09	BRCA	6c5a83f5-983f-434c-ac29-ddb84a7f1019
TCGA-C8-A26W-01A-11D-A16D-09	BRCA	d3db354e-f22c-4576-a7d7-6515f1c11002
TCGA-C8-A26X-01A-31D-A16D-09	BRCA	a5bc549a-1a1f-41b4-b548-14c448fed6c7

2019203664 24 May 2019

TCGA-C8-A26Z-01A-11D-A16D-09	BRCA	fa4f7af6-380f-4dbd-ba6a-8c0d22f56a9c
TCGA-C8-A273-01A-11D-A16D-09	BRCA	c5e6f325-5fd0-4cff-8eaf-6e23e016f605
TCGA-C8-A274-01A-11D-A16D-09	BRCA	5e6e7c20-47b3-4f0e-a3c7-8293993e39cf
TCGA-C8-A275-01A-21D-A16D-09	BRCA	7751a837-2656-4e3b-9182-556314c4f6a3
TCGA-C8-A278-01A-11D-A167-09	BRCA	7bc48524-1f69-4d85-9d16-6db7844543bd
TCGA-C8-A27A-01A-11D-A167-09	BRCA	d0fd3dcc-4ac7-4fe9-9fb8-c0676b6faabb
TCGA-C8-A27B-01A-11D-A167-09	BRCA	11e43e41-54b8-4232-b078-5062288d3868
TCGA-D8-A13Y-01A-11D-A10Y-09	BRCA	8bb90325-028e-491a-bbaf-2cf4b3b87cd6
TCGA-D8-A13Z-01A-11D-A10Y-09	BRCA	c3722c97-80f5-4eea-bf50-5a214134bbcc
TCGA-D8-A140-01A-11D-A10Y-09	BRCA	795f051e-01c4-4b49-b179-bd18ba24433c
TCGA-D8-A141-01A-11D-A10Y-09	BRCA	807791d8-b6c0-4722-bf5c-d5fa30baffc6
TCGA-D8-A143-01A-11D-A10Y-09	BRCA	db1763d1-fcae-4a01-a0cb-3019e292aa10
TCGA-D8-A145-01A-11D-A10Y-09	BRCA	af6ca646-499a-4e0a-a194-cacf72e5810b
TCGA-D8-A146-01A-31D-A10Y-09	BRCA	9a7548dc-fc79-4ad4-a324-0e9f63c91a20
TCGA-D8-A147-01A-11D-A10Y-09	BRCA	1f292323-cafc-4e45-bb4e-f5428e1a3276
TCGA-D8-A1J9-01A-11D-A13L-09	BRCA	6627e4b1-b34c-4aa2-836e-093061442a6d
TCGA-D8-A1JB-01A-11D-A13L-09	BRCA	54621c54-b7ef-48e4-aa68-e2fe10bf0afb
TCGA-D8-A1JC-01A-11D-A13L-09	BRCA	63a9d14f-d91a-47af-8ef6-8124193aa110
TCGA-D8-A1JD-01A-11D-A13L-09	BRCA	7df92725-fa63-494d-af9d-65c6ed76e023
TCGA-D8-A1JE-01A-11D-A13L-09	BRCA	bb34512b-2432-4256-968c-d7fdf38f126a
TCGA-D8-A1JF-01A-11D-A13L-09	BRCA	d31358da-639c-4fe5-9f7c-c17c31fd2865
TCGA-D8-A1JG-01B-11D-A13L-09	BRCA	0b15c6f7-8e3e-48ad-a4a2-97d2ada56c44
TCGA-D8-A1JH-01A-11D-A188-09	BRCA	9f59481d-be89-4361-8cc3-3f1d46702016
TCGA-D8-A1JI-01A-11D-A13L-09	BRCA	2c6a885b-0452-492c-8829-13ba4b2ac455
TCGA-D8-A1JJ-01A-31D-A14K-09	BRCA	412f96a6-6599-40a6-9dd2-afba8c643910
TCGA-D8-A1JK-01A-11D-A13L-09	BRCA	fadaa39d-ebd2-4887-ae54-1fca12287fcf
TCGA-D8-A1JL-01A-11D-A13L-09	BRCA	425dbc9f-6bee-412a-b77a-22a2724ea4c6
TCGA-D8-A1JM-01A-11D-A13L-09	BRCA	f66d4178-34f3-4f5d-aa0a-7fd03801033
TCGA-D8-A1JN-01A-11D-A13L-09	BRCA	c83c7d48-8671-4f27-b3dd-05411fa2f784
TCGA-D8-A1JP-01A-11D-A13L-09	BRCA	1e21a355-0cb6-4a43-b134-50ff88dacf92
TCGA-D8-A1JS-01A-11D-A13L-09	BRCA	4a9181d0-d3df-4791-99f0-4db076c22a3a
TCGA-D8-A1JT-01A-31D-A13L-09	BRCA	3be3972f-4125-44c3-94d6-0ddba2008fcf
TCGA-D8-A1JU-01A-11D-A13L-09	BRCA	7bff4f75-749d-4a63-9a64-0bcf1cd615ea
TCGA-D8-A1X5-01A-11D-A14G-09	BRCA	db4526d4-e344-4b5a-bb66-fd43b41764ca
TCGA-D8-A1X6-01A-11D-A14K-09	BRCA	1951aa38-481b-464c-9a78-0819312a0a93
TCGA-D8-A1X7-01A-11D-A14K-09	BRCA	7acb4232-db95-4889-942e-f1be897b4f2a
TCGA-D8-A1X8-01A-11D-A14K-09	BRCA	78c3c787-5731-4c38-8d7a-e5b503b11c36
TCGA-D8-A1X9-01A-12D-A159-09	BRCA	b5f65c3a-b922-4a81-863d-59b72b08d1bf
TCGA-D8-A1XA-01A-11D-A14G-09	BRCA	a362780b-8917-4438-9693-ec9fa84c352a
TCGA-D8-A1XB-01A-11D-A14G-09	BRCA	e5ca0f82-6fa9-4d54-adc7-385721f351f3
TCGA-D8-A1XC-01A-11D-A14G-09	BRCA	68fd3045-073d-4242-8a41-41b707fca625

2019203664 24 May 2019

TCGA-D8-A1XF-01A-11D-A14G-09	BRCA	e1587f32-2ff9-40f3-97dd-b45b0f14be46
TCGA-D8-A1XG-01A-11D-A14G-09	BRCA	800ff536-a1d2-4213-b85e-7780851c6378
TCGA-D8-A1XJ-01A-11D-A14K-09	BRCA	a37b27a2-c3b0-4f62-82a2-94e9205b1d6e
TCGA-D8-A1XL-01A-11D-A14K-09	BRCA	28d44e6e-c73f-4788-8ad4-2bd6572f643d
TCGA-D8-A1XM-01A-21D-A14K-09	BRCA	07418962-0a82-43a2-a66f-614903ea8380
TCGA-D8-A1XO-01A-11D-A14K-09	BRCA	b5ff68a2-da74-4608-941e-dbac40153077
TCGA-D8-A1XR-01A-11D-A14K-09	BRCA	5913c8ff-26ce-4f26-909e-3ed292d3c538
TCGA-D8-A1XS-01A-11D-A14K-09	BRCA	5d302c04-302e-4040-9429-37cd672e8d53
TCGA-D8-A1XT-01A-11D-A14K-09	BRCA	bc13601e-3e03-4d7d-8e6e-5b05ff500ea3
TCGA-D8-A1XU-01A-11D-A14K-09	BRCA	55c547ee-7cc9-4b7a-aaca-22f2a8c8c3a4
TCGA-D8-A1XV-01A-11D-A14K-09	BRCA	a76adfd1-8c89-4c13-b570-5ccc47043a70
TCGA-D8-A1XW-01A-11D-A14K-09	BRCA	f29405cc-d712-4562-ac02-ca3c89fb82af
TCGA-D8-A1XY-01A-11D-A14K-09	BRCA	edb6d161-8f50-4c11-8246-487c4ea9a55d
TCGA-D8-A1XZ-01A-11D-A14K-09	BRCA	381a9211-1f2b-4c14-895b-ee7fb6eb8c7f
TCGA-D8-A1Y0-01A-11D-A14K-09	BRCA	33ff7870-fa76-4e48-a223-a8e2441d8f53
TCGA-D8-A1Y1-01A-21D-A14K-09	BRCA	2ea6e540-6e2f-48a5-99e3-27a0107d07b7
TCGA-D8-A1Y2-01A-11D-A159-09	BRCA	9dbf62eb-0de7-4410-b44b-fdf59026d8e6
TCGA-D8-A1Y3-01A-11D-A159-09	BRCA	64fa29ff-534f-4b22-b0c4-513e8657edb1
TCGA-D8-A27E-01A-11D-A16D-09	BRCA	eab47cbb-eab0-4dd6-9cd0-f2700e5b6227
TCGA-D8-A27F-01A-11D-A16D-09	BRCA	fc6d77a9-121b-48ab-a899-713c3d1319a2
TCGA-D8-A27H-01A-11D-A16D-09	BRCA	78e51220-c9f8-44b2-bc1c-b34a56af3b54
TCGA-D8-A27I-01A-11D-A16D-09	BRCA	47c0db0a-fc37-4fa0-832c-e67f089d3889
TCGA-D8-A27K-01A-11D-A16D-09	BRCA	09fa0bc7-acb3-45b0-b687-977869c31d12
TCGA-D8-A27L-01A-11D-A16D-09	BRCA	10666107-dffb-4c51-b3ee-71e70cde7c88
TCGA-D8-A27M-01A-11D-A16D-09	BRCA	cb9257f9-ca3f-4c14-a680-6632175dd526
TCGA-D8-A27N-01A-11D-A16D-09	BRCA	6a411174-582a-4c68-bb04-5ea2e504bf7c
TCGA-D8-A27P-01A-11D-A16D-09	BRCA	94011b46-74e3-41c1-a3f6-6db1821d1778
TCGA-D8-A27R-01A-11D-A16D-09	BRCA	27741c13-8d5f-43b8-8651-caf69acef0e4
TCGA-D8-A27T-01A-11D-A16D-09	BRCA	ecabcc6a-2767-4ad8-ac4f-54cc3d081b6e
TCGA-D8-A27W-01A-11D-A16D-09	BRCA	b045d675-286b-4cf8-aed4-c7ff81a78919
TCGA-E2-A105-01A-11D-A10M-09	BRCA	2441f3e0-2016-4313-8c05-486759f5dd0f
TCGA-E2-A107-01A-11D-A10M-09	BRCA	5804fc1c-063b-429d-a652-22b0de416bd6
TCGA-E2-A108-01A-13D-A10M-09	BRCA	e3e394d4-2593-4bf9-86e4-2e79d8cb8dab
TCGA-E2-A109-01A-11D-A10M-09	BRCA	3585e133-b3c1-4d90-b5f2-2b867e0ae0ec
TCGA-E2-A10A-01A-21D-A10Y-09	BRCA	cd49ccc5-a776-4307-930c-298ba6cfd7f9
TCGA-E2-A10B-01A-11D-A10M-09	BRCA	9d712002-74cb-459a-b350-e9a4b49aac13
TCGA-E2-A10C-01A-21D-A10M-09	BRCA	2750ed41-0bd4-4cf4-98f5-762957cf80b7
TCGA-E2-A10F-01A-11D-A10M-09	BRCA	530b7e22-e70a-46ef-a0e8-bf2ef814850a
TCGA-E2-A14N-01A-31D-A135-09	BRCA	00c8d151-2223-4e36-8c66-6c09e42d8777
TCGA-E2-A14O-01A-31D-A10Y-09	BRCA	d6ab6f8d-0e65-40a3-bf98-7249e4075395
TCGA-E2-A14P-01A-31D-A12B-09	BRCA	35a96eee-113b-45cb-a999-81c13545b104

2019203664 24 May 2019

TCGA-E2-A14Q-01A-11D-A12B-09	BRCA	ee51cf6d-351f-48f8-ab93-639c27c50e9f
TCGA-E2-A14R-01A-11D-A10Y-09	BRCA	c7212115-1007-40cf-b9b5-7b25e2f5f2a4
TCGA-E2-A14S-01A-11D-A12B-09	BRCA	78f39325-e1d0-4181-87f4-cb7f00e886d7
TCGA-E2-A14T-01A-11D-A10Y-09	BRCA	14c1c6b6-575e-416b-b219-15552b62ea74
TCGA-E2-A14V-01A-11D-A12B-09	BRCA	703314fe-bfd5-45d5-9ed5-fcdce8a19fd6
TCGA-E2-A14W-01A-11D-A12B-09	BRCA	fbdc8659-e9cc-483f-bd0a-1a24b5ada1cf
TCGA-E2-A14X-01A-11D-A10Y-09	BRCA	74039acd-5aca-4c65-818c-3b577d295be0
TCGA-E2-A14Z-01A-11D-A10Y-09	BRCA	c83eaaca-ced5-4630-abb5-ef34db888753
TCGA-E2-A150-01A-11D-A12B-09	BRCA	446064de-ff64-4113-9080-360e5bf6d5e4
TCGA-E2-A152-01A-11D-A12B-09	BRCA	b266b370-425c-4146-8b72-59248436618e
TCGA-E2-A154-01A-11D-A10Y-09	BRCA	336e39fb-d407-4ced-b7bb-e8ff5329abdb
TCGA-E2-A155-01A-11D-A12B-09	BRCA	a966904f-e8dd-473c-8626-84c25d7e0d6c
TCGA-E2-A156-01A-11D-A12B-09	BRCA	26003dce-0fc6-4538-a392-c80e1ebaa1e4
TCGA-E2-A159-01A-11D-A10Y-09	BRCA	757c8a2d-90cf-4dab-a4dd-45f3cbdeaeeb
TCGA-E2-A15A-01A-11D-A12B-09	BRCA	b7e3eff1-65d5-491f-a726-35dc6752b370
TCGA-E2-A15C-01A-31D-A12B-09	BRCA	10c594a1-0843-4740-9d96-00211a9509fb
TCGA-E2-A15D-01A-11D-A10Y-09	BRCA	891295d6-4dd0-4ab4-bbce-13da7f3c30d0
TCGA-E2-A15E-01A-11D-A12B-09	BRCA	c6f107df-1186-4d6d-b5b5-2393e9369dd1
TCGA-E2-A15F-01A-11D-A10Y-09	BRCA	33edf937-b09f-49ec-8f4c-e05dee7ece1f
TCGA-E2-A15G-01A-11D-A12B-09	BRCA	d45bb60a-e73b-4b95-8637-e8d17fcc745
TCGA-E2-A15H-01A-11D-A12B-09	BRCA	7875c5b3-ced2-4669-a3d5-45739b850af7
TCGA-E2-A15I-01A-21D-A135-09	BRCA	9bec02b4-7cf0-4797-b1ac-253ef78a34af
TCGA-E2-A15J-01A-11D-A12Q-09	BRCA	e5fd7cbd-8fce-49e9-8d2c-d2a2e61367a5
TCGA-E2-A15O-01A-11D-A10Y-09	BRCA	39c1df91-b670-4f6b-b5ff-dbb6b66d30af
TCGA-E2-A15P-01A-11D-A10Y-09	BRCA	5f1853c2-6579-42d0-adc2-636b5de543e4
TCGA-E2-A15R-01A-11D-A10Y-09	BRCA	11799240-0275-48fe-84ef-85e188839bbe
TCGA-E2-A15S-01A-11D-A10Y-09	BRCA	01f78efa-ba0b-4263-81fd-d3d8ea1bc5fd
TCGA-E2-A15T-01A-11D-A10Y-09	BRCA	eff74709-36af-4da4-91c1-01100ddc7735
TCGA-E2-A1AZ-01A-11D-A12Q-09	BRCA	f961c932-cf37-47c8-8520-8d0d444dc94f
TCGA-E2-A1B0-01A-11D-A12Q-09	BRCA	14e3b00c-cbec-4733-8fa4-829b8e7d9808
TCGA-E2-A1B1-01A-21D-A12Q-09	BRCA	a6e77a14-e5e5-452e-a46f-5629ee8228e3
TCGA-E2-A1B4-01A-11D-A12Q-09	BRCA	a6aa4529-7996-4b66-9632-2559293db35d
TCGA-E2-A1B6-01A-31D-A12Q-09	BRCA	1aaf88fc-f7cb-4239-a420-224352194160
TCGA-E2-A1BD-01A-11D-A12Q-09	BRCA	f5ac1986-272b-48d2-9a73-4a550e38a997
TCGA-E2-A1IE-01A-11D-A188-09	BRCA	e416f05b-c7d2-479b-8068-803492e86d86
TCGA-E2-A1IF-01A-11D-A142-09	BRCA	7751c2d5-e548-4439-aac1-e7b9dce97583
TCGA-E2-A1IG-01A-11D-A142-09	BRCA	84da47a3-49e1-4f94-bea9-dd20b6627adb
TCGA-E2-A1IH-01A-11D-A188-09	BRCA	cd886e35-4201-4732-90c6-142d8fe309b1
TCGA-E2-A1II-01A-11D-A142-09	BRCA	698c8a73-c6b6-45bd-82fc-9bd0f140729d
TCGA-E2-A1IJ-01A-11D-A142-09	BRCA	3aff2da1-1647-4b95-abdb-c9db923cfc22
TCGA-E2-A1IK-01A-11D-A17G-09	BRCA	8577ac01-1274-4bd5-ab04-380eaa78d95b

2019203664 24 May 2019

TCGA-E2-A1IL-01A-11D-A14G-09	BRCA	1540ae03-7bb4-418b-afbc-44bf3ad60a31
TCGA-E2-A1IN-01A-11D-A13L-09	BRCA	9e85559f-098e-4b0f-8034-4798789e710b
TCGA-E2-A1IO-01A-11D-A142-09	BRCA	986e9b9f-ae15-4743-a150-d6ee11f3c077
TCGA-E2-A1IU-01A-11D-A14G-09	BRCA	7fcd5fda-8155-4b48-afb9-9e7958627113
TCGA-E2-A1L6-01A-11D-A13L-09	BRCA	f610239f-5610-4d7b-bc31-ae3ccb9c425d
TCGA-E2-A1L7-01A-11D-A142-09	BRCA	33a09072-6554-4d46-b738-0852624940af
TCGA-E2-A1L8-01A-11D-A13L-09	BRCA	04a7762f-2cbb-498b-ab4e-921406c1aec0
TCGA-E2-A1L9-01A-11D-A13L-09	BRCA	a50cd2b2-913d-41bf-94ad-45464547b348
TCGA-E2-A1LA-01A-11D-A142-09	BRCA	bdc4800-3258-446f-b6e5-3c8e2f46c656
TCGA-E2-A1LB-01A-11D-A142-09	BRCA	377b1816-61e1-431a-9952-71e4d58bbd48
TCGA-E2-A1LG-01A-21D-A14K-09	BRCA	7cdbe0e8-f614-4f54-b864-fd6b39e8ef1c
TCGA-E2-A1LH-01A-11D-A14G-09	BRCA	605f1d27-db45-449a-a68f-4888b8c786a1
TCGA-E2-A1LI-01A-12D-A159-09	BRCA	c812374c-8bc9-4ccf-9157-fbd9d162ee1e
TCGA-E2-A1LK-01A-21D-A14G-09	BRCA	4e84eed6-82a8-4e91-b0fd-61ec6ef69ce9
TCGA-E2-A1LL-01A-11D-A142-09	BRCA	47312f61-5ef4-4f25-9320-8fbb4758790e
TCGA-E2-A1LS-01A-12D-A159-09	BRCA	40087f80-85f6-4cc4-95c9-0639153dd3f4
TCGA-E9-A1N3-01A-12D-A159-09	BRCA	6c3891a9-baa9-4309-9974-d82fd5f97417
TCGA-E9-A1N4-01A-11D-A14K-09	BRCA	a3784a48-47a7-4587-91dd-5b8873a24ca9
TCGA-E9-A1N5-01A-11D-A14G-09	BRCA	432a9f5e-0f2a-4cd2-a910-ee9ee30c1ff3
TCGA-E9-A1N8-01A-11D-A142-09	BRCA	cac57844-0e46-489b-8d94-cccc5788c050
TCGA-E9-A1N9-01A-11D-A14G-09	BRCA	2aa7a1db-40a5-421b-97ab-1031e6fa7f04
TCGA-E9-A1NA-01A-11D-A142-09	BRCA	a3d223eb-20e6-40b9-9f07-e5f865bd2439
TCGA-E9-A1NC-01A-12W-A16L-09	BRCA	2ba4c398-b94b-49f8-bb88-9d0cb3347d2c
TCGA-E9-A1ND-01A-11D-A142-09	BRCA	8e72652d-3b99-47b2-87fe-04b96b243722
TCGA-E9-A1NE-01A-21D-A14K-09	BRCA	dbd34322-ac40-41f0-acc7-7bfd06afdf67
TCGA-E9-A1NF-01A-11D-A14G-09	BRCA	cd428bec-fc31-4d2d-9e6c-c8f30608d797
TCGA-E9-A1NG-01A-21D-A14K-09	BRCA	1cbf389d-1ec8-4543-880f-4ef64c55a44b
TCGA-E9-A1NH-01A-11D-A14G-09	BRCA	13c312ec-0add-4758-ab8d-c193e2e08c6d
TCGA-E9-A1NI-01A-11W-A16H-09	BRCA	3bf0b169-f870-4887-be06-414f20f1dcf0
TCGA-E9-A1QZ-01A-21D-A167-09	BRCA	2d47b244-e5e4-4645-91cb-71de1d685a95
TCGA-E9-A1R0-01A-22D-A16D-09	BRCA	c09eaa03-c14c-4a96-a505-4d999e45270e
TCGA-E9-A1R2-01A-11D-A14G-09	BRCA	b321a2d9-5345-4891-b450-bfd696c6efb0
TCGA-E9-A1R3-01A-31D-A14K-09	BRCA	ba6af877-7a23-4738-a867-01a5dd8a8050
TCGA-E9-A1R4-01A-21D-A14G-09	BRCA	15d9c916-a12e-48a0-8a0f-8c240c54bd37
TCGA-E9-A1R5-01A-11D-A14K-09	BRCA	a04ba6e9-2bc4-4cab-96d8-0820e0390d84
TCGA-E9-A1R6-01A-11D-A14G-09	BRCA	b8a1805d-a43a-4433-a90b-01715e8cc554
TCGA-E9-A1R7-01A-11D-A14K-09	BRCA	b3991854-6634-4428-bef7-a7d9ad9cca30
TCGA-E9-A1RA-01A-11D-A14G-09	BRCA	6d067461-2002-468e-934d-2721f6cb97ff
TCGA-E9-A1RB-01A-11D-A17G-09	BRCA	2ce0333c-deca-4199-a06c-edc43e5575fc
TCGA-E9-A1RC-01A-11D-A159-09	BRCA	5b5e7eb2-8efc-4681-ab8c-49a9cc4ac6d6
TCGA-E9-A1RD-01A-11D-A159-09	BRCA	23f7a698-eab1-40f1-926c-c95d4ed8213d

2019203664 24 May 2019

TCGA-E9-A1RE-01A-11D-A159-09	BRCA	4a9c0873-f496-48a4-853c-2b41b2dbaa9e
TCGA-E9-A1RF-01A-11D-A159-09	BRCA	43983619-d863-4816-a334-445f6ca36541
TCGA-E9-A1RG-01A-11D-A14G-09	BRCA	81896525-0e3f-47ff-9b0d-95b45aef718c
TCGA-E9-A1RH-01A-21D-A167-09	BRCA	2ecb84c0-c307-4fa9-85e3-2f722dd365a3
TCGA-E9-A1RI-01A-11D-A167-09	BRCA	661c0074-dac9-44c6-bebc-202cfb9fb735
TCGA-E9-A226-01A-21D-A159-09	BRCA	866e5e9b-4e6c-49e2-9ea6-560f9bd99c2b
TCGA-E9-A227-01A-11D-A159-09	BRCA	15eb25c4-f4a7-446e-b654-ae39ccd2cf00
TCGA-E9-A228-01A-31D-A159-09	BRCA	4a804a8d-7dc8-4b5b-9537-b7f8f7133bda
TCGA-E9-A229-01A-31D-A17G-09	BRCA	a27fa57d-d1ad-4534-a933-0fdcc5f06a8c
TCGA-E9-A22A-01A-11D-A159-09	BRCA	25bf7831-6878-4bac-b23d-e94a555b2232
TCGA-E9-A22B-01A-11D-A159-09	BRCA	e46a5d19-2dd7-4c34-8fff-6276278c58b3
TCGA-E9-A22D-01A-11D-A159-09	BRCA	3dfdc7fd-3f69-4297-a4cf-1a05b75d302f
TCGA-E9-A22E-01A-11D-A159-09	BRCA	a1d7dafc-a755-44a6-b45b-dc6aae309d3e
TCGA-E9-A22G-01A-11D-A159-09	BRCA	2be1b92a-6041-4d2b-9cf8-b9723921987f
TCGA-E9-A22H-01A-11D-A159-09	BRCA	42993dbb-b99b-4b48-8038-05cf14fec886
TCGA-E9-A243-01A-21D-A167-09	BRCA	c6bb16c6-cb0f-44c6-93e7-6c55d0958f82
TCGA-E9-A244-01A-11D-A167-09	BRCA	9edf63e8-ae94-4b2f-8521-b56dadec21cd5
TCGA-E9-A245-01A-22D-A16D-09	BRCA	bdd591f9-21d1-4ce5-bfde-30e7ac3d440a
TCGA-E9-A247-01A-11D-A167-09	BRCA	7c184a2b-d857-444a-936c-43e38a196df9
TCGA-E9-A248-01A-11D-A167-09	BRCA	fee90b4e-f005-4b40-a9af-d1e590b1e8a8
TCGA-E9-A249-01A-11D-A167-09	BRCA	2799ad7e-d6f0-4919-b7f6-1c957b4c74f8
TCGA-E9-A24A-01A-11D-A167-09	BRCA	d11d3770-a4f4-4d15-94f4-149cca27d391
TCGA-E9-A295-01A-11D-A16D-09	BRCA	f3d5e986-046f-4f75-8abc-67a3b99f742d
TCGA-EW-A1IW-01A-11D-A13L-09	BRCA	8b8732c3-78b1-409b-bc8c-c482575361bb
TCGA-EW-A1IX-01A-12D-A142-09	BRCA	01ea194f-dc06-4e15-9b9e-1c73668040e0
TCGA-EW-A1IY-01A-11D-A188-09	BRCA	01d3fdff-b447-4925-a5cb-c5fd70c97278
TCGA-EW-A1IZ-01A-11D-A188-09	BRCA	18db4143-48cc-424c-8d23-46cf23056528
TCGA-EW-A1J1-01A-11D-A188-09	BRCA	4b8d51b3-8393-45d4-a73d-3c22c561d6f3
TCGA-EW-A1J2-01A-21D-A13L-09	BRCA	c906931e-dc1a-434c-96cd-58088762f1e7
TCGA-EW-A1J3-01A-11D-A13L-09	BRCA	ac13b81a-ca05-432c-918a-0c9c8170bf46
TCGA-EW-A1J5-01A-11D-A13L-09	BRCA	98bb3025-0637-4106-8621-12df7b5d662f
TCGA-EW-A1J6-01A-11D-A188-09	BRCA	d95c5cb1-d081-47fa-8ac0-1ade7652a0af
TCGA-EW-A1OV-01A-11D-A142-09	BRCA	e27ca8f5-3f76-4531-87ea-ba3a44f6830d
TCGA-EW-A1OX-01A-11D-A142-09	BRCA	7828f9cf-aa93-44a0-8070-efdf90a677f0
TCGA-EW-A1OY-01A-11D-A142-09	BRCA	925323a2-ca03-48f4-8c37-1a8a6f8a6daa
TCGA-EW-A1OZ-01A-11D-A142-09	BRCA	a73152be-2293-403d-940b-74ac05810808
TCGA-EW-A1P0-01A-11D-A142-09	BRCA	6475f4dd-782c-411a-b7ce-9c9ebd0753b8
TCGA-EW-A1P1-01A-31D-A14G-09	BRCA	28a56927-bab8-4a8c-bel1-f46e37ea34c1
TCGA-EW-A1P3-01A-11D-A142-09	BRCA	e783933d-1c24-4cd5-82b7-0d680f9c3c22
TCGA-EW-A1P4-01A-21D-A142-09	BRCA	204e4ef3-e6b8-469f-9024-56c6f6f07afd
TCGA-EW-A1P5-01A-11D-A142-09	BRCA	84b4da42-9b73-4448-9185-a12857ab422f

2019203664 24 May 2019

TCGA-EW-A1P6-01A-11D-A142-09	BRCA	eef5cea9-82f6-4001-8e2c-701e43a9787a
TCGA-EW-A1P7-01A-21D-A142-09	BRCA	402abf40-5a01-467d-a5be-b9101743f34b
TCGA-EW-A1P8-01A-11D-A142-09	BRCA	e55f338f-97e2-4394-ae23-c92606069485
TCGA-EW-A1PA-01A-11D-A142-09	BRCA	56c8aca4-b3bd-4791-b05d-0b2338b6346d
TCGA-EW-A1PB-01A-11D-A142-09	BRCA	9ddf2119-a222-4fa5-a9f3-0bec7eeea36b
TCGA-EW-A1PD-01A-11D-A142-09	BRCA	5a288561-bf14-4cb9-b2f5-9ece0e038319
TCGA-EW-A1PE-01A-11D-A142-09	BRCA	54377bac-8f52-4116-b7e5-b71a8a721ac4
TCGA-EW-A1PG-01A-11D-A142-09	BRCA	bd3801e2-c5bb-4116-9ce3-97903fc6956e
TCGA-EW-A1PH-01A-11D-A14K-09	BRCA	ce860c6f-c87a-4a45-92df-ca34bf2e8b2
TCGA-GI-A2C8-01A-11D-A16D-09	BRCA	535a899d-67ca-4500-8dda-63a331a3611c
TCGA-AA-3664-01A-01W-0900-09	COAD	9cff122a-9960-4f2e-ba5b-94736bad7f2b
TCGA-AA-3666-01A-02W-0900-09	COAD	d7065ea5-88b0-4b56-a367-5defa0d9ed27
TCGA-AA-3667-01A-01W-0900-09	COAD	c2799cdc-c6f7-44ba-a72c-e1632b434575
TCGA-AA-3672-01A-01W-0900-09	COAD	04dc0b16-834c-4351-b3b9-58fe558c634d
TCGA-AA-3673-01A-01W-0900-09	COAD	7952f001-8901-44b4-833e-824282967118
TCGA-AA-3678-01A-01W-0900-09	COAD	968fea30-df40-425f-87ba-935942dbd450
TCGA-AA-3679-01A-02W-0900-09	COAD	94cfbc05-df22-4db0-9aa0-808faab01c61
TCGA-AA-3680-01A-01W-0900-09	COAD	20dd1d44-2321-4a84-b8b9-894073c6acd3
TCGA-AA-3681-01A-01W-0900-09	COAD	e5fea94c-f2ab-4476-b641-f2764eb0d026
TCGA-AA-3684-01A-02W-0900-09	COAD	6ecc0812-6ce3-4569-9868-6c4936236682
TCGA-AA-3685-01A-02W-0900-09	COAD	db8d5d6c-c200-4ffc-a1bb-8465044cefad
TCGA-AA-3688-01A-01W-0900-09	COAD	7224118e-b762-4e72-8bee-9e87c37aac7f
TCGA-AA-3692-01A-01W-0900-09	COAD	6e2f4d01-6413-473e-98f4-9256ca4285d5
TCGA-AA-3693-01A-01W-0900-09	COAD	45ea6cb9-8d5e-4470-bd07-a2c59ddc5cf0
TCGA-AA-3695-01A-01W-0900-09	COAD	db143a45-b2c5-4dce-98d4-d15dccc5b757
TCGA-AA-3696-01A-01W-0900-09	COAD	9e1f1824-12e2-42be-aa57-e0d0b4079a4c
TCGA-AA-3715-01A-01W-0900-09	COAD	554258ce-99c3-49a3-bfbf-131ec867a0e9
TCGA-AA-3812-01A-01W-0900-09	COAD	28087364-af53-4ac4-b1b2-bbe54b71c040
TCGA-AA-3814-01A-01W-0900-09	COAD	733e8b21-718b-405d-b860-ed36c70a8411
TCGA-AA-3818-01A-01W-0900-09	COAD	9ddb06a8-300e-40d2-8f6a-c851e2f90d90
TCGA-AA-3819-01A-01W-0900-09	COAD	0192a572-a235-400d-8fb1-af81e40d3763
TCGA-AA-3831-01A-01W-0900-09	COAD	7843d5c1-373d-4a55-82b8-db2f8ead890c
TCGA-AA-3833-01A-01W-0900-09	COAD	9ea5c555-6e44-4313-8572-779a099efaaa
TCGA-AA-3837-01A-01W-0900-09	COAD	888c1825-a44b-49cb-bed1-09db01e54b75
TCGA-AA-3848-01A-01W-0900-09	COAD	729fbad4-0152-44e5-b26b-dffc1f7dcf70
TCGA-AA-3852-01A-01W-0900-09	COAD	1ee1ab0a-cd8c-49d5-ab8c-0d2a2f94724f
TCGA-AA-3854-01A-01W-0900-09	COAD	2a7ecd84-d49c-484c-a918-381769835ebc
TCGA-AA-3856-01A-01W-0900-09	COAD	7a07d137-7936-486d-aeb5-6d9598fe4660
TCGA-AA-3858-01A-01W-0900-09	COAD	99e41f17-b760-4b34-8230-39aa42db46fd
TCGA-AA-3860-01A-02W-0900-09	COAD	57869735-96fd-4439-ba2d-583df6fc32a0
TCGA-AA-3875-01A-01W-0900-09	COAD	06e6b2e8-634e-4b03-989e-0d192b60b64a

2019203664 24 May 2019

TCGA-AA-3966-01A-01W-1073-09	COAD	689f1a40-4315-48bc-8b05-75d800e17b44
TCGA-AA-3994-01A-01W-1073-09	COAD	4348f66a-e104-4fdd-bdee-2f346832835d
TCGA-AA-A004-01A-01W-A00E-09	COAD	0b856311-aa63-44b7-a191-9d6d8308c3d0
TCGA-AA-A00N-01A-02W-A00E-09	COAD	dfb1aec9-d196-49e6-bdb1-9318222b8121
TCGA-AA-A00O-01A-02W-A00E-09	COAD	0328eea5-c89c-4462-8af8-48a28ed38537
TCGA-AA-A010-01A-01W-A00E-09	COAD	77cdeb19-16fa-4330-921c-e21f17c2298e
TCGA-AA-A017-01A-01W-A00E-09	COAD	a0ad6347-d20c-494a-a094-b816c4fec5de
TCGA-AA-A01D-01A-01W-A00E-09	COAD	e00404be-0bea-4893-89cf-cc24073f10b1
TCGA-AA-A01I-01A-02W-A00E-09	COAD	ee78a7e5-6ddb-4d06-8fb1-ba7300af59e1
TCGA-AA-A01K-01A-01W-A00E-09	COAD	7b7c405e-65c8-4633-ac54-0a112fb478ac
TCGA-AA-A024-01A-02W-A00E-09	COAD	45a6b8e2-a4a7-400e-ba7a-f93c29f50fe4
TCGA-AA-A029-01A-01W-A00E-09	COAD	41be5565-479e-4c56-b48b-1de52dad2299
TCGA-AA-A02F-01A-01W-A00E-09	COAD	68c4226b-dfb4-4130-b50e-94839bcb1b0f
TCGA-AA-A02H-01A-01W-A00E-09	COAD	1cbf3771-fb49-4517-83ba-8e112fcb1d00
TCGA-AA-A02J-01A-01W-A00E-09	COAD	5d03450f-b249-4dcd-927b-713158acc8b2
TCGA-AA-A02W-01A-01W-A00E-09	COAD	2104138f-b09d-4452-91e1-c4a10382f009
TCGA-AY-4070-01A-01W-1073-09	COAD	a7a74785-31cf-4527-bae2-991d7df97b5f
TCGA-AY-4071-01A-01W-1073-09	COAD	80aa3f17-b072-4e59-a6fc-1afe016fa477
TCGA-02-0003-01A-01D-1490-08	GBM	458f13e0-34f3-4a92-b3b3-9a3c2ee3ef23
TCGA-02-0033-01A-01D-1490-08	GBM	39d1f122-31d0-4e1c-95a7-0e65e75b1457
TCGA-02-0047-01A-01D-1490-08	GBM	ce03026e-b756-43a2-972d-b3a4dcda5491
TCGA-02-0055-01A-01D-1490-08	GBM	9cd89af4-5118-4adb-aa1d-fbd03bf42a33
TCGA-02-2470-01A-01D-1494-08	GBM	0b35f2ff-2a08-4585-a1a9-cfc6a9f5b224
TCGA-02-2483-01A-01D-1494-08	GBM	4d7f2c74-862b-4aad-98e1-fa831f14a905
TCGA-02-2485-01A-01D-1494-08	GBM	0332b017-17d5-4083-8fc4-9d6f8fdbbbde
TCGA-02-2486-01A-01D-1494-08	GBM	3331813c-f538-4833-b5eb-a214b7d52334
TCGA-06-0119-01A-08D-1490-08	GBM	0cda6181-c62b-4ced-a543-d6138fd2e94a
TCGA-06-0122-01A-01D-1490-08	GBM	08c54819-32fa-455d-a443-fc71dfd3f03a
TCGA-06-0124-01A-01D-1490-08	GBM	6ae82bf8-7076-43fb-a541-4c7db5d49280
TCGA-06-0125-02A-11D-2280-08	GBM	96e3db14-2bb1-4f68-aed6-5e794750c96e
TCGA-06-0126-01A-01D-1490-08	GBM	c3c3059d-e2fb-45ea-80b5-99fb040cba29
TCGA-06-0128-01A-01D-1490-08	GBM	c5688535-bda4-4831-aaba-e0c19101d7b0
TCGA-06-0129-01A-01D-1490-08	GBM	73e7aa35-91b4-4392-bbb9-9ec21f30250c
TCGA-06-0130-01A-01D-1490-08	GBM	c09f0ebd-d604-49a3-9738-0c65fd47fbf9
TCGA-06-0132-01A-02D-1491-08	GBM	53c2e159-5774-499f-b0d1-e04fa3faf5c3
TCGA-06-0137-01A-01D-1490-08	GBM	37c11dfc-c37c-4cb6-bd81-9e0a7789b0f1
TCGA-06-0139-01A-01D-1490-08	GBM	c84ff17d-436d-49c1-aef2-b998ffe4a693
TCGA-06-0140-01A-01D-1490-08	GBM	18c94086-d2cc-45cd-9bad-f8968a042d5e
TCGA-06-0141-01A-01D-1490-08	GBM	5af251d5-e76b-480c-8142-6d6fbfce0b2a
TCGA-06-0142-01A-01D-1490-08	GBM	4bce79ce-c59c-4d86-b25f-28c8edda1651



2019203664 24 May 2019

TCGA-06-0145-01A-01W-0224-08	GBM	8f904068-2967-4b38-8813-3ad0a99e4af8
TCGA-06-0151-01A-01D-1491-08	GBM	5fea9ebc-8c1b-4078-af87-79c7f5b5470b
TCGA-06-0152-01A-02W-0323-08	GBM	79062efd-2b09-4798-a504-0a18ca30ef2d
TCGA-06-0154-01A-03D-1491-08	GBM	f5045707-3ddd-4ade-959a-b368437752fb
TCGA-06-0155-01B-01D-1492-08	GBM	2dc59e9b-3a60-4178-9fa0-81cf5171622d
TCGA-06-0157-01A-01D-1491-08	GBM	b1e62d8e-24d2-4118-8cd0-3142acebdd5b
TCGA-06-0158-01A-01D-1491-08	GBM	14580533-4a0c-47ca-bb51-c233700de35c
TCGA-06-0165-01A-01D-1491-08	GBM	1728988e-0877-4194-92c5-92c1ee6c5f5b
TCGA-06-0166-01A-01D-1491-08	GBM	70157018-a3c5-4ef8-9314-f8715a3438a4
TCGA-06-0167-01A-01D-1491-08	GBM	d530c696-235d-4a41-944d-e7f7ae21aa17
TCGA-06-0168-01A-01D-1491-08	GBM	2b3bab1e-dddd-4c2c-b5ec-7bb6e700e070
TCGA-06-0169-01A-01D-1490-08	GBM	06053a14-2d9a-4df0-a79b-81bda36bf3c3
TCGA-06-0171-02A-11D-2280-08	GBM	39520be3-a2af-4189-acf4-9d239363333a
TCGA-06-0173-01A-01D-1491-08	GBM	0908aac1-d3b7-4eec-96f2-a28c3738388c
TCGA-06-0174-01A-01D-1491-08	GBM	017c9167-0354-41e4-ad50-fb38fcb5668c
TCGA-06-0178-01A-01D-1491-08	GBM	a4fa779b-d116-4696-b170-60f3e215e9fb
TCGA-06-0184-01A-01D-1491-08	GBM	a5a2e50f-dc7e-44cc-bffe-b675a707bf53
TCGA-06-0185-01A-01W-0254-08	GBM	bc62d57d-b536-41ab-a344-e765fd3f7439
TCGA-06-0188-01A-01W-0254-08	GBM	cc0c78e7-1d76-45e6-b043-dc209bb9a32a
TCGA-06-0189-01A-01D-1491-08	GBM	25c64c53-746c-4e92-976a-8bd947fb9c7f
TCGA-06-0190-02A-01D-2280-08	GBM	c065761d-f775-457f-bda0-4c7c257a701e
TCGA-06-0192-01B-01W-0348-08	GBM	43d7bc6f-be9b-4d5e-bcec-4fb30b0d9b65
TCGA-06-0195-01B-01D-1491-08	GBM	2a2fac52-44aa-41f7-ae27-de6b7eba8ff1
TCGA-06-0209-01A-01D-1491-08	GBM	b4a7de67-14b6-4b8c-abbe-9eaa990d905e
TCGA-06-0210-02A-01D-2280-08	GBM	b60392fb-43d9-4c9c-b91b-ded40492e61c
TCGA-06-0211-02A-02D-2280-08	GBM	3914c02e-44ad-4c96-8464-61aa95b42c49
TCGA-06-0213-01A-01D-1491-08	GBM	885f9df7-fc27-43c2-9acc-833c410b2db1
TCGA-06-0214-01A-02D-1491-08	GBM	08ac57ec-0036-4134-a9bb-f22eaa27ab0d
TCGA-06-0216-01B-01D-1492-08	GBM	eac73a02-b2e0-4601-9bd6-aceb07594fe8
TCGA-06-0219-01A-01D-1491-08	GBM	a6c6c454-058f-41ec-93c3-3cff44bed149
TCGA-06-0221-02A-11D-2280-08	GBM	b2d17671-d2e1-4c97-8b01-a976d5abe1d6
TCGA-06-0237-01A-02D-1491-08	GBM	a50b5271-484a-436e-ac6f-6074071015fd
TCGA-06-0238-01A-02D-1492-08	GBM	7e8c6b9f-0fec-49ea-9ecb-c9ba1fb4cb74
TCGA-06-0240-01A-03D-1491-08	GBM	20f74001-1cb8-451d-8173-5795fa93432b
TCGA-06-0241-01A-02D-1491-08	GBM	4dd4035a-c800-41b0-85c9-02531d2910ed
TCGA-06-0644-01A-02D-1492-08	GBM	2553c4d2-5f6a-4eba-84b6-04c4761ebf5c
TCGA-06-0645-01A-01D-1492-08	GBM	3f458a3c-baac-427d-b3d6-6f15104a8886
TCGA-06-0646-01A-01D-1492-08	GBM	89742b5d-0256-48c7-8d8f-41b6e5e5b561
TCGA-06-0648-01A-01W-0323-08	GBM	33f8304e-11c3-4a9d-ad21-ffea555309dc
TCGA-06-0649-01B-01W-0348-08	GBM	27af6a5f-993d-41f0-a9af-65e5a8cc41d4
TCGA-06-0650-01A-02D-1696-08	GBM	89af56db-b7f9-41d2-af62-c9b2ee7b540f

2019203664 24 May 2019

TCGA-06-0686-01A-01W-0348-08	GBM	4af220fa-c00b-40b1-ae82-b2c256a3d3fe
TCGA-06-0743-01A-01D-1492-08	GBM	430e6ca1-d678-4373-8d8d-9d93412c8012
TCGA-06-0744-01A-01W-0348-08	GBM	d80afd62-48a6-4da4-8026-e6384e86cf62
TCGA-06-0745-01A-01W-0348-08	GBM	188c837e-6389-48eb-8b77-91c8a2f099ac
TCGA-06-0747-01A-01W-0348-08	GBM	7773738f-f5dd-48ae-870c-aa89aea77450
TCGA-06-0749-01A-01W-0348-08	GBM	1121aced-04ae-4ba2-a467-c5b8445a0a76
TCGA-06-0750-01A-01W-0348-08	GBM	fc15ced3-5ed1-4f88-8789-09ec713bd613
TCGA-06-0875-01A-01W-0424-08	GBM	862cc896-a0dc-4f02-9940-8c9a5016027b
TCGA-06-0876-01A-01W-0424-08	GBM	c2f27319-4e84-4b12-bce1-623ea20722be
TCGA-06-0877-01A-01W-0424-08	GBM	dda2b842-fd8b-4d14-9aa5-3cd3abc0a0e1
TCGA-06-0878-01A-01W-0424-08	GBM	07869e29-9ced-4be5-9a6c-8fd3c29ae487
TCGA-06-0879-01A-01W-0424-08	GBM	f96b8966-e0c2-4fb6-b3f6-e76d7953d537
TCGA-06-0881-01A-02W-0424-08	GBM	1069a9d0-9978-4c01-8516-947200264314
TCGA-06-0882-01A-01W-0424-08	GBM	385a3692-3208-479f-9f39-37fb65501b80
TCGA-06-1804-01A-01D-1696-08	GBM	d9a1ff46-8d28-451e-937f-bdad42bdd64
TCGA-06-1806-01A-02D-1845-08	GBM	beb40d7c-3861-4efe-9b1d-34ba68a66c9d
TCGA-06-2557-01A-01D-1494-08	GBM	c27290e4-6835-448a-abdc-df8ddd5f4630
TCGA-06-2558-01A-01D-1494-08	GBM	19f41e2f-cff9-4f04-ba65-6d945bf05edd
TCGA-06-2559-01A-01D-1494-08	GBM	8df5560b-9f8f-4636-bdb2-1af8b45df1ba
TCGA-06-2561-01A-02D-1494-08	GBM	f989ad3-f9b6-4061-90ef-30e0eab0a706
TCGA-06-2562-01A-01D-1494-08	GBM	6cb3467e-0ad8-4dd9-8b9b-9103629fd16f
TCGA-06-2563-01A-01D-1494-08	GBM	1d81086c-bf8b-4459-abcf-1ff905c6bf74
TCGA-06-2564-01A-01D-1494-08	GBM	9225f366-b08b-4c43-a09f-a16b3bcfb5aa
TCGA-06-2565-01A-01D-1494-08	GBM	c866726d-2d95-4d23-b3d4-0e28a0b3da00
TCGA-06-2567-01A-01D-1494-08	GBM	d40a4861-b8c4-4fb8-815a-4e82801eedca
TCGA-06-2569-01A-01D-1494-08	GBM	617eec0b-78e9-4663-946c-c01e7e00a7de
TCGA-06-2570-01A-01D-1495-08	GBM	04339769-517c-448d-a7ca-951f83608c60
TCGA-06-5408-01A-01D-1696-08	GBM	ed8ca267-0153-475b-9154-361af62ff767
TCGA-06-5410-01A-01D-1696-08	GBM	67244284-dc40-46cb-a2ac-3f4a38f7bbe4
TCGA-06-5411-01A-01D-1696-08	GBM	2fdab641-d73b-4f9a-aa4c-c1944f131a69
TCGA-06-5412-01A-01D-1696-08	GBM	b6be0866-b8ae-4767-8cdc-e1dd4f78f440
TCGA-06-5413-01A-01D-1696-08	GBM	72c13e51-0dd2-4e96-af37-aa471407436f
TCGA-06-5414-01A-01D-1486-08	GBM	7aa16ff4-169a-4206-83d1-a2495fb56f62
TCGA-06-5415-01A-01D-1486-08	GBM	fca08ee9-b480-4dc7-be56-f1eb03b56f7c
TCGA-06-5417-01A-01D-1486-08	GBM	66350d36-6662-4d4c-9cf8-e052a17cddba
TCGA-06-5418-01A-01D-1486-08	GBM	ae28fd78-d254-46fa-aba1-1353931aa414
TCGA-06-5856-01A-01D-1696-08	GBM	0bd9b573-712b-4da1-9c33-7b7f43d4af31
TCGA-06-5858-01A-01D-1696-08	GBM	951799e6-12f0-4cf6-8732-f2e044db7210
TCGA-06-5859-01A-01D-1696-08	GBM	bb404507-ab63-4d82-99c6-f3297bffc46f
TCGA-06-6388-01A-12D-1845-08	GBM	c9214f8b-6684-4e29-812c-2a44963e8914
TCGA-06-6389-01A-11D-1696-08	GBM	10911471-5404-42d5-817e-f9616e7dacfc

2019203664 24 May 2019

TCGA-06-6390-01A-11D-1696-08	GBM	f04b6bde-63e0-41c9-89f7-07673f9de0f6
TCGA-06-6391-01A-11D-1696-08	GBM	40fc77dc-46df-4487-925f-1d87c5326661
TCGA-06-6693-01A-11D-1845-08	GBM	45ca8f53-6d0e-4659-a81f-258184b7a70e
TCGA-06-6694-01A-12D-1845-08	GBM	b5a5717d-0e3d-4b44-82f3-5b68187beb52
TCGA-06-6695-01A-11D-1845-08	GBM	13817acd-8c1e-4154-8b88-7cdc5f2660a7
TCGA-06-6697-01A-11D-1845-08	GBM	7d947ed1-1315-459e-b973-f3dd624d9e39
TCGA-06-6698-01A-11D-1845-08	GBM	d605a279-c0ea-467c-a423-cdf21547f87e
TCGA-06-6699-01A-11D-1845-08	GBM	90ba858d-e3bb-40d8-98ee-eeb127c58409
TCGA-06-6700-01A-12D-1845-08	GBM	6da42a38-94dd-49b7-8a03-df0f7174ca6f
TCGA-06-6701-01A-11D-1845-08	GBM	fad178f1-385b-4f94-bd29-567c1aa0a8fc
TCGA-08-0386-01A-01D-1492-08	GBM	90bf7f8f-4b8c-410f-afa6-2b439ec82f97
TCGA-12-0615-01A-01D-1492-08	GBM	a6068793-51e4-4762-9150-cdfb030e8ade
TCGA-12-0616-01A-01D-1492-08	GBM	b0e2fed7-38bd-48d8-a786-ac574c9fa5be
TCGA-12-0618-01A-01D-1492-08	GBM	390fc5e9-787e-4a3f-86c8-e3e0e7e43824
TCGA-12-0619-01A-01D-1492-08	GBM	79c65ab5-1924-4710-96e4-31e9a615a53e
TCGA-12-0688-01A-02D-1492-08	GBM	143dc738-1694-4105-8115-9cc0902ef35b
TCGA-12-0692-01A-01W-0348-08	GBM	937fb2a6-3856-4086-a327-8d8e593b7b7b
TCGA-12-0821-01A-01W-0424-08	GBM	357e3a3c-cceb-4b38-bc35-6fe8f5be5ac8
TCGA-12-1597-01B-01D-1495-08	GBM	7d35c610-cc06-4aa5-8c96-2f7b7465069f
TCGA-12-3649-01A-01D-1495-08	GBM	2580567a-8f51-4cb7-9525-bba987c55e36
TCGA-12-3650-01A-01D-1495-08	GBM	8b1d52e2-489b-4972-9bef-1690ccd2bac9
TCGA-12-3652-01A-01D-1495-08	GBM	ab460bc2-e504-4b7f-8533-ab06448a55bc
TCGA-12-3653-01A-01D-1495-08	GBM	fdc52d48-828e-481f-ba1c-0264f1da38a5
TCGA-12-5295-01A-01D-1486-08	GBM	796f5741-3b2d-46e5-b74f-e5a76604a401
TCGA-12-5299-01A-02D-1486-08	GBM	a44954fc-49f2-489a-8593-7de98963e4f8
TCGA-12-5301-01A-01D-1486-08	GBM	891fc6bc-d0a7-4064-842c-43d500b4ef5d
TCGA-14-0740-01B-01D-1845-08	GBM	f49859c4-adf9-4c53-8288-8a7ad65a940d
TCGA-14-0781-01B-01D-1696-08	GBM	13878ec6-fce7-423e-b545-6656145e9d2c
TCGA-14-0786-01B-01D-1492-08	GBM	75fa4de1-29fd-4b54-b63a-add459f1d69c
TCGA-14-0787-01A-01W-0424-08	GBM	184b240c-ebf1-4ecf-87eb-aae0718cd81f
TCGA-14-0789-01A-01W-0424-08	GBM	3462087f-f791-43b4-b9d9-b11cc48eaf9e
TCGA-14-0790-01B-01D-1494-08	GBM	d63d49a0-9413-4583-a7a5-cb2c202cc085
TCGA-14-0813-01A-01W-0424-08	GBM	754cd19e-a319-4ddf-887b-ddca4914cdf9
TCGA-14-0817-01A-01W-0424-08	GBM	a5f06dfc-e9b2-46a6-bee5-604d2839baad
TCGA-14-0862-01B-01D-1845-08	GBM	f0b7d451-8190-45a4-8242-bf698f05243d
TCGA-14-0871-01A-01W-0424-08	GBM	0cc45f48-0967-42dc-8035-e76c6bd0a3fd
TCGA-14-1034-02B-01D-2280-08	GBM	7cae6c0b-36fe-411b-bbba-093a4c846d84
TCGA-14-1043-01B-11D-1845-08	GBM	a439c422-8728-42f5-8dda-6e9e1590478c
TCGA-14-1395-01B-11D-1845-08	GBM	8825b7a5-dfac-4e21-b4ec-05161b1341e9
TCGA-14-1450-01B-01D-1845-08	GBM	7ec7f174-13f6-44b1-83e3-6f35a244f00e
TCGA-14-1456-01B-01D-1494-08	GBM	e525e774-f925-41cd-9822-15aeeee29190

2019203664 24 May 2019

TCGA-14-1823-01A-01W-0643-08	GBM	1c3ddf6a-e496-4b87-833b-084d814b6876
TCGA-14-1825-01A-01W-0643-08	GBM	f0d7cb8b-995c-419b-a366-aadb156879bc
TCGA-14-1829-01A-01W-0643-08	GBM	c69ca476-9e11-4f6e-a4f5-6952f792a580
TCGA-14-2554-01A-01D-1494-08	GBM	53dec97d-0464-4ffd-8e2e-95b2b9a03af0
TCGA-15-0742-01A-01W-0348-08	GBM	3c015456-02f0-4473-be25-b53166da41ea
TCGA-15-1444-01A-02D-1696-08	GBM	cbd4d4e7-f1c4-446c-8dbc-ce06c872ec14
TCGA-16-0846-01A-01W-0424-08	GBM	cf3eb226-36c2-4498-a5c1-3f161de6fa3f
TCGA-16-0861-01A-01W-0424-08	GBM	deab6efd-8213-4f35-a897-060c605ce58b
TCGA-16-1045-01B-01W-0611-08	GBM	c92c1d87-0df9-4c5a-baef-2dd26ad6d75a
TCGA-19-1390-01A-01D-1495-08	GBM	d7e8e408-0a8f-4177-ad38-08c5da484ed0
TCGA-19-2619-01A-01D-1495-08	GBM	b765a4c7-4fe8-444c-95bd-6a4d03af1432
TCGA-19-2620-01A-01D-1495-08	GBM	6de41ac1-229b-40b9-a494-5588c284351d
TCGA-19-2623-01A-01D-1495-08	GBM	a14ae5c3-fee0-4ed7-9080-51056ce62ef2
TCGA-19-2624-01A-01D-1495-08	GBM	a8f86b64-914c-4d89-897b-33bccdd1759f7
TCGA-19-2625-01A-01D-1495-08	GBM	b0833912-0cb6-4d2a-bd18-9fc211793b30
TCGA-19-2629-01A-01D-1495-08	GBM	56ffaa35-814c-4c0b-b3c6-d4514d34fec2
TCGA-19-5947-01A-11D-1696-08	GBM	d5e7dd90-ead0-40fe-94c5-bc740cb509ab
TCGA-19-5950-01A-11D-1696-08	GBM	8d6626e2-ea32-4b1d-8f2b-389294121692
TCGA-19-5951-01A-11D-1696-08	GBM	57cf584c-8c95-42ec-9cb0-707228b70010
TCGA-19-5952-01A-11D-1696-08	GBM	483cad63-ca73-4b31-b4c7-9d73f2cb4186
TCGA-19-5953-01B-12D-1845-08	GBM	a0180465-3685-4735-a76e-acbeebfa635a
TCGA-19-5954-01A-11D-1696-08	GBM	cf4e06e-203f-4a6f-8aa9-60828e0d4d68
TCGA-19-5955-01A-11D-1696-08	GBM	c8abde95-f4d7-4d48-879b-bd584eaf8a25
TCGA-19-5958-01A-11D-1696-08	GBM	fd385a8e-d6dc-4e65-a023-ce485793c410
TCGA-19-5959-01A-11D-1696-08	GBM	dd3e4733-7154-4162-9a61-a3a685e5f561
TCGA-19-5960-01A-11D-1696-08	GBM	b8151614-b08f-49a3-ab6f-2e780f765a17
TCGA-26-1442-01A-01D-1696-08	GBM	17e25583-886e-4dc9-802b-35e67971073d
TCGA-26-5132-01A-01D-1486-08	GBM	d1132127-1250-43af-9c16-425798a3d1a7
TCGA-26-5133-01A-01D-1486-08	GBM	533051f3-5ea5-41a4-8727-11dc6d786607
TCGA-26-5134-01A-01D-1486-08	GBM	11956d98-4ba5-486f-ae79-05aacebe0631
TCGA-26-5135-01A-01D-1486-08	GBM	2ce48f01-2f61-49d9-a56a-7438bf4a37d7
TCGA-26-5136-01B-01D-1486-08	GBM	39e0587b-1b04-4c68-8ae4-3ae7781e8017
TCGA-26-5139-01A-01D-1486-08	GBM	8199001b-a3c9-47e1-97cf-943fa8030f46
TCGA-26-6173-01A-11D-1845-08	GBM	af373e42-cbbf-4a89-8479-bdd413011885
TCGA-26-6174-01A-21D-1845-08	GBM	3ba04f15-48f4-4851-a21f-8fa7cc9eac6b
TCGA-27-1830-01A-01W-0643-08	GBM	b391392a-9865-4bf4-b5f1-fa4fb2ad1343
TCGA-27-1831-01A-01D-1494-08	GBM	9880c3c9-5685-42a7-8fe9-7585ea1a1d37
TCGA-27-1832-01A-01W-0643-08	GBM	7ea7ee22-55a6-4748-9607-d93a6a367122
TCGA-27-1833-01A-01W-0643-08	GBM	4d8d34d9-7069-436c-84d6-ace5760c2aec
TCGA-27-1834-01A-01W-0643-08	GBM	a6c0824e-3d2a-498a-af77-44ea96ba5ce4
TCGA-27-1835-01A-01D-1494-08	GBM	6d5fd73b-4cad-44ae-8c79-67f2b9d30328

2019203664 24 May 2019

TCGA-27-1836-01A-01D-1494-08	GBM	8c58f090-31a3-4b2f-93e7-1ae6f6d73350
TCGA-27-1837-01A-01D-1494-08	GBM	61ad1d55-21a9-49c4-925b-54a24703afda
TCGA-27-1838-01A-01D-1494-08	GBM	881af1d2-3fbc-44dd-8362-e6c386345cf6
TCGA-27-2518-01A-01D-1494-08	GBM	dae099ff-330f-492b-a06d-6f975e9e5aea
TCGA-27-2519-01A-01D-1494-08	GBM	b0daafab-b783-4cfc-9f7d-8017d98e80bb
TCGA-27-2521-01A-01D-1494-08	GBM	3678d5f3-9a29-4750-b0a9-20e971ff6aa4
TCGA-27-2523-01A-01D-1494-08	GBM	d60f54f5-b154-42c4-99fb-cea4e7a33dc7
TCGA-27-2524-01A-01D-1494-08	GBM	ce679bfd-fbf9-4c78-822e-37d2322d544b
TCGA-27-2526-01A-01D-1494-08	GBM	bc1abcb7-b4e9-4447-b0c5-0fc09401eec0
TCGA-27-2527-01A-01D-1494-08	GBM	b8b00995-ada6-493b-bafc-0f6c9def41c9
TCGA-27-2528-01A-01D-1494-08	GBM	374cbd87-428e-4509-85c1-b7d3302c30a0
TCGA-28-1747-01C-01D-1494-08	GBM	7c746081-ac14-4ae2-9564-d67d52f2627c
TCGA-28-1753-01A-01D-1494-08	GBM	c7143f1e-458c-4129-aa91-61b8e4b90e53
TCGA-28-2499-01A-01D-1494-08	GBM	28583f40-c3fc-4213-91c1-99d7d536551e
TCGA-28-2501-01A-01D-1696-08	GBM	2a2cb25d-4069-4824-b09d-2d49634ed284
TCGA-28-2502-01B-01D-1494-08	GBM	707466c8-138a-4ed0-b806-6579464595cb
TCGA-28-2509-01A-01D-1494-08	GBM	f4a62fe0-cee2-487a-9a8a-4cd98d8380df
TCGA-28-2510-01A-01D-1696-08	GBM	5f2dc303-9859-4b63-8aab-c387da4b2cc1
TCGA-28-2513-01A-01D-1494-08	GBM	52dd150e-abd7-4fd2-abe9-09428c5a610c
TCGA-28-2514-01A-02D-1494-08	GBM	6eef4a0e-3fef-4529-8193-21b380d96344
TCGA-28-5204-01A-01D-1486-08	GBM	e9590ee4-92d8-4afb-908e-0c816d2b82f3
TCGA-28-5207-01A-01D-1486-08	GBM	2d795a16-bdc3-44f0-8c01-6eeec0e1a0b1
TCGA-28-5208-01A-01D-1486-08	GBM	76209124-b3f0-4bb2-8b2c-e268abdefe2b
TCGA-28-5209-01A-01D-1486-08	GBM	ef8b63f3-b820-46ac-a99c-3d401a6203d7
TCGA-28-5211-01C-11D-1845-08	GBM	f8dc846b-1b17-4699-9dc5-3f79e21eee94
TCGA-28-5213-01A-01D-1486-08	GBM	b866e742-5ed0-4d7d-b96c-52f8f6f37142
TCGA-28-5214-01A-01D-1486-08	GBM	c992e603-30c9-4e30-a425-8050189db4f8
TCGA-28-5215-01A-01D-1486-08	GBM	34c77b5d-c3a6-4e83-96f4-fadd729362d9
TCGA-28-5216-01A-01D-1486-08	GBM	cde8518a-ce8e-4b54-ab21-5ad4171ab1b3
TCGA-28-5218-01A-01D-1486-08	GBM	68008a98-3889-4dd2-bcf9-f1f6cbca6355
TCGA-28-5219-01A-01D-1486-08	GBM	f016e9f7-66a3-4f50-b9cd-58b1c8a955e9
TCGA-28-5220-01A-01D-1486-08	GBM	f7b80486-fa19-49c7-8ace-ea61338677d7
TCGA-28-6450-01A-11D-1696-08	GBM	5f10d0c5-05b8-44bb-98ce-bbea41820850
TCGA-32-1970-01A-01D-1494-08	GBM	65723119-bdfe-46f0-b629-c171023abd71
TCGA-32-1979-01A-01D-1696-08	GBM	0c81ebb9-20a6-40c1-9be2-17b99517e988
TCGA-32-1980-01A-01D-1696-08	GBM	9b267205-1994-46ff-8d0f-56625dae7c1b
TCGA-32-1982-01A-01D-1494-08	GBM	9cf7c4cb-ce19-4b79-9163-b74369603e22
TCGA-32-1986-01A-01D-1494-08	GBM	5afe3ffc-ba3a-49bb-9837-091b600cbb35
TCGA-32-2615-01A-01D-1495-08	GBM	65e3c804-b1a3-4e21-9407-90a6edc4e290

2019203664 24 May 2019

TCGA-32-2632-01A-01D-1495-08	GBM	27203e18-af27-478c-a224-8bca77a81c90
TCGA-32-2634-01A-01D-1495-08	GBM	52b2a114-4f8c-4e02-af9d-24c4a05d4ca0
TCGA-32-2638-01A-01D-1495-08	GBM	1e103221-ab46-4a5c-9b96-5e34f0d49fc2
TCGA-32-5222-01A-01D-1486-08	GBM	f48abf4d-f1fb-48bf-97a1-0c38435b6af7
TCGA-41-2571-01A-01D-1495-08	GBM	36349a22-17eb-48d8-9b69-1921ee7576ff
TCGA-41-2573-01A-01D-1495-08	GBM	fadc9e2a-d97d-4e86-a814-4f32f8cfd7a5
TCGA-41-2575-01A-01D-1495-08	GBM	4943e80a-d098-49cd-8261-1d53d42f8223
TCGA-41-3392-01A-01D-1495-08	GBM	c08b37a5-9938-4ab0-8183-d73b01cb9a89
TCGA-41-5651-01A-01D-1696-08	GBM	5fd77ba9-5015-4d8b-86a0-582e5c76bdd6
TCGA-41-6646-01A-11D-1845-08	GBM	6272bb0c-c47b-4cd2-9f59-398f1a75f020
TCGA-74-6573-01A-12D-1845-08	GBM	0941e50e-1205-49ed-8735-1f86eaf87718
TCGA-74-6575-01A-11D-1845-08	GBM	f4ec96d6-d7fc-4892-9a36-80802f387a12
TCGA-74-6577-01A-11D-1845-08	GBM	5be142d5-b6f7-4e1e-ae75-49b302b332a2
TCGA-74-6578-01A-11D-1845-08	GBM	a2ae2128-4d95-4261-a30d-bd6be58de8e0
TCGA-74-6584-01A-11D-1845-08	GBM	cedd2d49-371b-4b12-8aac-6a9bd38f2ccb
TCGA-76-4925-01A-01D-1486-08	GBM	ca2fa3da-18d6-4e8b-8081-b07022ead6a8
TCGA-76-4926-01B-01D-1486-08	GBM	3c93cb58-d39b-4a5e-907a-8b5438630d21
TCGA-76-4927-01A-01D-1486-08	GBM	2dc69425-dbfd-4228-ab78-541062b5c445
TCGA-76-4928-01B-01D-1486-08	GBM	6e30f277-875e-4ab8-bc7c-0a5121cde6d1
TCGA-76-4929-01A-01D-1486-08	GBM	af4f8b89-837a-48b7-b0e7-12aec23fc285
TCGA-76-4931-01A-01D-1486-08	GBM	d4a27742-ca69-4f54-9bce-ec33d8481fed
TCGA-76-4932-01A-01D-1486-08	GBM	81656daa-af7c-430c-afa3-0eb10eb9a695
TCGA-76-4934-01A-01D-1486-08	GBM	e9bc4701-562e-4d35-a949-53a61fd96651
TCGA-76-4935-01A-01D-1486-08	GBM	c8d06abf-437d-4bc9-804b-44345af74f36
TCGA-76-6191-01A-12D-1696-08	GBM	4dbf66ef-4108-4a86-a8eb-6ba8cdefb4a2
TCGA-76-6192-01A-11D-1696-08	GBM	c29754bc-44e8-4980-98a1-b8d69700f4a3
TCGA-76-6193-01A-11D-1696-08	GBM	6a751d65-5fcf-4c03-8253-8f1b8faccab2
TCGA-76-6280-01A-21D-1845-08	GBM	9096e339-7730-4d7a-acab-a6c4d26e52c3
TCGA-76-6282-01A-11D-1696-08	GBM	1c7f63d2-a2a4-42c3-928b-319695a66443
TCGA-76-6283-01A-11D-1845-08	GBM	a4083f8b-0c39-4d65-a372-b494caf84f8d
TCGA-76-6285-01A-11D-1696-08	GBM	28380a2f-d302-45fb-a4c5-31b2fd150bc3
TCGA-76-6286-01A-11D-1845-08	GBM	45d03116-6cff-4074-9c26-2e5f1a8854d3
TCGA-76-6656-01A-11D-1845-08	GBM	fe66f11a-e03d-49c5-befe-db74ef55ce61
TCGA-76-6657-01A-11D-1845-08	GBM	6ba47878-126c-420d-b3c1-ca7ea8c182d0
TCGA-76-6660-01A-11D-1845-08	GBM	f4960945-c464-49c2-8ad6-d73a6fa47b20
TCGA-76-6661-01B-11D-1845-08	GBM	8329e910-7ccf-4e84-b468-bd6cf23327a2
TCGA-76-6662-01A-11D-1845-08	GBM	7f7c80ca-6ad9-4820-83ca-5248b3873eea
TCGA-76-6663-01A-11D-1845-08	GBM	624864ad-3178-4a6d-a0cf-7fa3e9bdf8da
TCGA-76-6664-01A-11D-1845-08	GBM	6a8f17c6-060d-492e-8a39-53d9ac7035a4
TCGA-81-5910-01A-11D-1696-08	GBM	bef79a66-30e6-4554-982e-38d8eab46114
TCGA-81-5911-01A-12D-1845-08	GBM	a501e01b-249c-43cb-ae2-f355c3c697dd

2019203664 24 May 2019

TCGA-87-5896-01A-01D-1696-08	GBM	640c33a6-a7df-4dba-9c21-367a9a839f0f
TCGA-BA-4074-01A-01D-1434-08	HNSC	2c84e904-0cbc-4645-b7e5-94ec45e61268
TCGA-BA-4075-01A-01D-1434-08	HNSC	5b3fec35-d127-4cb5-859b-edac003acdf3
TCGA-BA-4076-01A-01D-1434-08	HNSC	93dda6a6-907d-4dc2-9391-36dd09c767c6
TCGA-BA-4077-01B-01D-1434-08	HNSC	9b37211a-2150-4d33-bc6a-9d6a0a429708
TCGA-BA-4078-01A-01D-1434-08	HNSC	f02d0332-d7c8-4d2a-98ca-dbe7826437ae
TCGA-BA-5149-01A-01D-1512-08	HNSC	6e98841c-ce33-4b7e-882d-ce65707d4c10
TCGA-BA-5151-01A-01D-1434-08	HNSC	dac15d7e-3930-4fcb-b752-4a4f00449ddd
TCGA-BA-5152-01A-02D-1870-08	HNSC	18da68fd-3bfb-45a3-ba28-4c90555b4e68
TCGA-BA-5153-01A-01D-1434-08	HNSC	363ccc6f-dab0-413e-bc42-d738ee25abcd
TCGA-BA-5555-01A-01D-1512-08	HNSC	65dc1531-713b-41ba-a567-caa12340c0cf
TCGA-BA-5556-01A-01D-1512-08	HNSC	d31fda32-363b-44e4-8f2c-834a66f46b87
TCGA-BA-5557-01A-01D-1512-08	HNSC	7caa2a2f-3b77-46f0-9886-37f6e4278d83
TCGA-BA-5558-01A-01D-1512-08	HNSC	97a47fa4-c857-4483-9572-07012c10e9d5
TCGA-BA-5559-01A-01D-1512-08	HNSC	c0845927-fc9a-41b2-9431-619952878e18
TCGA-BA-6868-01B-12D-1912-08	HNSC	51647474-f538-4e96-babd-e742f1fb793f
TCGA-BA-6869-01A-11D-1870-08	HNSC	b78a2501-f312-41a2-ab19-7c18d8dfbac6
TCGA-BA-6870-01A-11D-1870-08	HNSC	2fdd3f42-cb2f-4faf-8a47-b8bfee058265
TCGA-BA-6871-01A-11D-1870-08	HNSC	a8a04117-0ebc-4c27-83d6-441be47e5fd3
TCGA-BA-6872-01A-11D-1870-08	HNSC	182b2a39-4881-402a-a907-b51aa114584a
TCGA-BA-6873-01A-11D-1870-08	HNSC	f65b842c-257e-4ac7-a155-23d3ac12d41c
TCGA-BA-7269-01A-11D-2012-08	HNSC	2e8ffdfc-48f5-41e0-9192-d761f3b518ef
TCGA-BB-4217-01A-11D-2078-08	HNSC	5916ef19-7838-4621-a869-de8c2b34931c
TCGA-BB-4223-01A-01D-1434-08	HNSC	c4799ee4-3014-4b2f-ba7e-9771ab5dc3f1
TCGA-BB-4224-01A-01D-1434-08	HNSC	cfa7d658-031d-4cd4-9ca3-ceaa201f702d
TCGA-BB-4225-01A-01D-1434-08	HNSC	85fb5611-0dee-4a73-8aa1-1629ad929173
TCGA-BB-4227-01A-01D-1870-08	HNSC	c1b315bb-773b-4fd0-88ec-d11044996adc
TCGA-BB-4228-01A-01D-1434-08	HNSC	6fd93146-1026-4362-982b-d1fc70e3c65d
TCGA-BB-7861-01A-11D-2229-08	HNSC	77cb5c69-f15e-45de-a060-0e8b52648209
TCGA-BB-7862-01A-21D-2229-08	HNSC	84c57a23-1428-488e-9275-9f2bc3673476
TCGA-BB-7863-01A-11D-2229-08	HNSC	0bf356d5-1259-4042-9860-2f793f5fe32c
TCGA-BB-7864-01A-11D-2229-08	HNSC	1d6324a3-8bb4-45d1-89b3-134ffca01aec
TCGA-BB-7866-01A-11D-2229-08	HNSC	8d6ae619-b33e-453c-aa6d-dda14cd5a337
TCGA-BB-7870-01A-11D-2229-08	HNSC	d584f4ec-09b0-40fe-bba2-256b6cf6974e
TCGA-BB-7871-01A-11D-2229-08	HNSC	8e13f8a5-5d80-4e34-bffa-54ae808114e7
TCGA-BB-7872-01A-11D-2229-08	HNSC	c05cb0b5-b288-48fb-bdc0-ee9acd6643a8
TCGA-CN-4723-01A-01D-1434-08	HNSC	d5d71c48-1a2d-4d7d-8f2c-e3a68352776b
TCGA-CN-4725-01A-01D-1434-08	HNSC	57ffe9d-193b-48f6-8d5b-3c2eca854d93
TCGA-CN-4726-01A-01D-1434-08	HNSC	2201e681-a727-4fd2-aded-cbc543b2232
TCGA-CN-4727-01A-01D-1434-08	HNSC	b24fc60a-fe83-4743-a6d3-d90b807412e1
TCGA-CN-4728-01A-01D-1434-08	HNSC	e450fec8-66dd-4798-8197-4206b8ba7c4d

2019203664 24 May 2019

TCGA-CN-4729-01A-01D-1434-08	HNSC	7240e742-9315-4fb8-b6f7-28bfe69410a8
TCGA-CN-4730-01A-01D-1434-08	HNSC	543bbfe3-4a11-49af-b445-303f0912bfc3
TCGA-CN-4731-01A-01D-1434-08	HNSC	31ffd2d8-ee97-4002-9737-08c044878ace
TCGA-CN-4733-01A-02D-1870-08	HNSC	12880a34-83d1-4075-b62a-9fc61d18ca09
TCGA-CN-4734-01A-01D-1434-08	HNSC	fd54bbfa-62a2-4d8b-88fb-b74b91e1b958
TCGA-CN-4735-01A-01D-1434-08	HNSC	369ebdf4-ee27-414d-978d-3698711fae98
TCGA-CN-4736-01A-01D-1434-08	HNSC	788337f5-722c-45d6-8ca4-8037c489cb64
TCGA-CN-4737-01A-01D-1434-08	HNSC	4c6857bb-f20f-4ac9-9c2c-cb83c5387a74
TCGA-CN-4738-01A-02D-1512-08	HNSC	1d3b16fd-f98b-45ef-a423-861975f098b6
TCGA-CN-4739-01A-02D-1512-08	HNSC	7d6cc6ef-6bb0-44ab-bac1-c8f7198d1d8a
TCGA-CN-4740-01A-01D-1434-08	HNSC	40308868-8d79-484b-85a4-257142763d72
TCGA-CN-4741-01A-01D-1434-08	HNSC	3486c689-d7ae-4ce8-8df5-ac8271b4661d
TCGA-CN-4742-01A-02D-1512-08	HNSC	1fa89bda-b719-445a-85d2-76ce8c484b15
TCGA-CN-5355-01A-01D-1434-08	HNSC	0d93e8bc-69d5-47aa-b4bb-bf7b0ade92d6
TCGA-CN-5356-01A-01D-1434-08	HNSC	aad13fa4-b2e7-4c89-9936-57cf7a5e16a4
TCGA-CN-5358-01A-01D-1512-08	HNSC	498c0b1f-678f-4f70-b0d1-aad89bfa2a23
TCGA-CN-5359-01A-01D-1434-08	HNSC	dcf1e53d-22dc-4b11-9b3f-e421bc28b835
TCGA-CN-5360-01A-01D-1434-08	HNSC	174f1ea8-abcf-44ee-b17b-9687b3ab6dae
TCGA-CN-5361-01A-01D-1434-08	HNSC	5eea0205-e539-48de-b94c-4bb68c74ec96
TCGA-CN-5363-01A-01D-1434-08	HNSC	203f8426-6ec5-427a-9ccf-ec2b4683504d
TCGA-CN-5364-01A-01D-1434-08	HNSC	22078e53-2c9e-4ae4-a166-34488f259ee8
TCGA-CN-5365-01A-01D-1434-08	HNSC	a419a54c-58b4-4682-aaca-ed85697dd2a0
TCGA-CN-5366-01A-01D-1434-08	HNSC	161342fd-4cfa-4fc8-9708-7bb815b137c6
TCGA-CN-5367-01A-01D-1434-08	HNSC	57adb398-48c5-4a14-a43e-f79a19befbda
TCGA-CN-5369-01A-01D-1434-08	HNSC	4c8e6937-9fd7-41cc-ac74-d8b75235d4b3
TCGA-CN-5370-01A-01D-2012-08	HNSC	f4ca6755-68ca-4702-b08b-65005d31e9be
TCGA-CN-5373-01A-01D-1434-08	HNSC	00988676-1e9b-4e00-b4aa-a8f86c21b206
TCGA-CN-5374-01A-01D-1434-08	HNSC	28d5a97b-3f3d-4595-9034-8491999fcf40
TCGA-CN-6010-01A-11D-1683-08	HNSC	2d9693f3-0917-42be-97b8-4dc15cc4d3f6
TCGA-CN-6011-01A-11D-1683-08	HNSC	0e0aa5da-2cb2-47b8-b000-83a07d68ed29
TCGA-CN-6012-01A-11D-1683-08	HNSC	c5d99faa-ef68-4f08-af97-d722bcc383f5
TCGA-CN-6013-01A-11D-1683-08	HNSC	992de9b5-c394-48e7-b4e3-4c4aeacb4a23
TCGA-CN-6016-01A-11D-1683-08	HNSC	fc6e29c-864d-483f-a848-8a61202d9516
TCGA-CN-6017-01A-11D-1683-08	HNSC	7cd89cbe-6bd9-41a2-a042-345fa0a09866
TCGA-CN-6018-01A-11D-1683-08	HNSC	33815edd-bb4f-4f05-bc82-94eafe423652
TCGA-CN-6019-01A-11D-1683-08	HNSC	00769a89-ffc5-46f5-a42e-25b3eae886c2
TCGA-CN-6020-01A-11D-1683-08	HNSC	1f33c4c7-4f08-44a2-91f5-7ed2d7da68f0
TCGA-CN-6021-01A-11D-1683-08	HNSC	e62a2c4d-18e3-4ec8-8d93-40e055e65be4
TCGA-CN-6022-01A-21D-1683-08	HNSC	90cd2296-7133-4cbe-99cb-84b084eb88cd
TCGA-CN-6023-01A-11D-1683-08	HNSC	d03b8f96-c932-4abf-b508-f4e1b50739ee
TCGA-CN-6024-01A-11D-1683-08	HNSC	0604584e-0654-4b00-94fc-45e76588000c



2019203664 24 May 2019

TCGA-CN-6988-01A-11D-1912-08	HNSC	230b06a8-5f6e-41db-bb59-19e4e6c9afaf
TCGA-CN-6989-01A-11D-1912-08	HNSC	61cd2198-d85e-4eae-b9c6-e36be372595b
TCGA-CN-6992-01A-11D-1912-08	HNSC	7a70356c-74a3-40c3-bd32-3049da642831
TCGA-CN-6994-01A-11D-1912-08	HNSC	157b67ad-f092-4ea3-b557-0406839e6905
TCGA-CN-6995-01A-31D-2012-08	HNSC	c0b6813d-4b3e-479e-81a7-1e5c2de89b0d
TCGA-CN-6996-01A-11D-1912-08	HNSC	c063bec5-c716-4ea2-843a-e9f0bec3b540
TCGA-CN-6997-01A-11D-2012-08	HNSC	11b531cc-d9d9-496a-8448-e654ba71c414
TCGA-CN-6998-01A-23D-2012-08	HNSC	9c364f7e-5b90-44ef-9f80-250e428989ef
TCGA-CQ-5323-01A-01D-1683-08	HNSC	892067ef-c465-46ea-8f91-10636dd0081b
TCGA-CQ-5324-01A-01D-1683-08	HNSC	67b184fe-c4f4-49f3-938e-5370eb6246b9
TCGA-CQ-5325-01A-01D-1683-08	HNSC	22b6abf5-aad8-46ab-9b87-e3c12309cb59
TCGA-CQ-5326-01A-01D-1870-08	HNSC	199249f9-808d-4565-bb6b-82724f61edaa
TCGA-CQ-5327-01A-01D-1683-08	HNSC	da19d7bc-9748-4cd4-bd54-4792894838f0
TCGA-CQ-5329-01A-01D-1683-08	HNSC	5aa9b6fc-4169-4346-98fb-4c711d08d701
TCGA-CQ-5330-01A-01D-1683-08	HNSC	4ce7e702-9b62-459e-b2b4-a26cabba3a93
TCGA-CQ-5331-01A-02D-1870-08	HNSC	d2c2d3db-dbc0-44f1-b625-17f3f819c122
TCGA-CQ-5332-01A-01D-1683-08	HNSC	4fdf4f0d-0a55-4b5e-8545-65f1aad37c10
TCGA-CQ-5334-01A-01D-1683-08	HNSC	39978192-2119-4910-a2f6-53834a2b1bf2
TCGA-CQ-6218-01A-11D-1912-08	HNSC	d3717097-7cdb-446f-a020-78c770362656
TCGA-CQ-6219-01A-11D-1912-08	HNSC	c6263b94-0ffe-40e7-9184-deb427c67802
TCGA-CQ-6220-01A-11D-1912-08	HNSC	65e67eda-16a4-4dfd-94a9-546c76d94a02
TCGA-CQ-6221-01A-11D-2078-08	HNSC	d6166f0d-c0b5-44a3-814d-0c94c5bc41b0
TCGA-CQ-6222-01A-11D-1912-08	HNSC	de2c492f-5cd8-4330-a5de-36f693ec31af
TCGA-CQ-6223-01A-11D-1912-08	HNSC	be7cb5b4-1d09-479c-8bf2-a9e7abde575f
TCGA-CQ-6224-01A-11D-1912-08	HNSC	c03d51a0-8731-430d-a792-280e01629e8f
TCGA-CQ-6225-01A-11D-1912-08	HNSC	cd311590-3c69-4ff2-8fbd-cb5b0f21975e
TCGA-CQ-6227-01A-11D-1912-08	HNSC	ca62509e-d477-41ca-9bc2-3f20c2dd4e49
TCGA-CQ-6228-01A-11D-1912-08	HNSC	655e502b-1a6e-4eab-a948-4120d6c31c29
TCGA-CQ-6229-01A-11D-1912-08	HNSC	07e76152-9e83-42a5-9111-c39a2310a2e4
TCGA-CQ-7065-01A-11D-2078-08	HNSC	64c422bb-a531-4636-8e68-bdaf212df6dc
TCGA-CQ-7067-01A-11D-2229-08	HNSC	01f46aa2-e15b-4544-add5-c783868b6c26
TCGA-CQ-7068-01A-11D-2078-08	HNSC	97a96e61-f2dc-4af4-807a-3925c1ffbf43
TCGA-CR-5243-01A-01D-1512-08	HNSC	297e8b35-5b8b-4d5b-b812-86165f949a20
TCGA-CR-5247-01A-01D-2012-08	HNSC	3b5b07b4-29ef-4a55-b6ab-93352613f631
TCGA-CR-5248-01A-01D-2012-08	HNSC	e5af63d7-e8b2-4a76-8b39-6ee652ad8e5f
TCGA-CR-5249-01A-01D-1512-08	HNSC	42bf9ca3-47d8-45ff-bccf-bda80af58d22
TCGA-CR-5250-01A-01D-1512-08	HNSC	49e54f5a-9b3a-47ff-b6cc-a1eaf54fd136
TCGA-CR-6467-01A-11D-1870-08	HNSC	2a7f5a16-9330-45a1-9024-1cff1cdb5714
TCGA-CR-6470-01A-11D-1870-08	HNSC	30bc4d1e-f0cb-44c5-a32c-b4b690cd6cc5
TCGA-CR-6471-01A-11D-1870-08	HNSC	c087e87f-867c-45dd-8645-5ab774e4827c
TCGA-CR-6472-01A-11D-1870-08	HNSC	52f12c71-2473-4411-aad6-318a3496e82c

2019203664 24 May 2019

TCGA-CR-6473-01A-11D-1870-08	HNSC	9f3396a0-a38d-4069-b65a-c4c4dd6187ad
TCGA-CR-6474-01A-11D-1870-08	HNSC	6b4369e1-cf03-4a40-9a66-fc67bfb946b3
TCGA-CR-6477-01A-11D-1870-08	HNSC	e02f3646-a500-4781-ad44-2f62661a883d
TCGA-CR-6478-01A-11D-1870-08	HNSC	c21f40c6-4260-4def-8cca-1c11895b35b0
TCGA-CR-6480-01A-11D-1870-08	HNSC	7ee5501e-5463-4481-b798-3d23bfb4f113
TCGA-CR-6481-01A-11D-1870-08	HNSC	5e7d2531-81c1-48bb-9c0a-1867d1f83f92
TCGA-CR-6482-01A-11D-1870-08	HNSC	684bcd80-30fb-49e5-b72a-09502a9d1468
TCGA-CR-6484-01A-11D-1870-08	HNSC	e72df726-1575-4789-afac-3b15a7643401
TCGA-CR-6487-01A-11D-1870-08	HNSC	d4df06d7-97e1-4f22-83a7-993fdcd3a4da
TCGA-CR-6488-01A-12D-2078-08	HNSC	8bfa9606-b24d-4803-b551-2e86fb02ae5e
TCGA-CR-6491-01A-11D-1870-08	HNSC	a32853ad-b6a3-4147-ae5a-f48fad71581e
TCGA-CR-6492-01A-12D-2078-08	HNSC	d4550d39-4f32-48ab-b049-2fe623332d07
TCGA-CR-6493-01A-11D-1870-08	HNSC	f061abfa-4554-4328-9e8f-b84dd2aa4b45
TCGA-CR-7364-01A-11D-2012-08	HNSC	f5047f1e-5088-4d30-927d-e64147fe661d
TCGA-CR-7365-01A-11D-2012-08	HNSC	ec114413-a950-4e74-abc8-98857af8b9ad
TCGA-CR-7367-01A-11D-2012-08	HNSC	b82e34db-7b0e-4bbd-bc42-ba063ac42409
TCGA-CR-7368-01A-11D-2129-08	HNSC	4b194ab3-d213-4a7a-be46-909b4f0c7291
TCGA-CR-7369-01A-11D-2129-08	HNSC	f16a5c08-c9f8-442e-ba13-45681cacda40
TCGA-CR-7370-01A-11D-2129-08	HNSC	9f8ec337-85f7-4b01-a2b6-5db9a9e62f30
TCGA-CR-7371-01A-11D-2012-08	HNSC	68201be8-a1a9-4c78-ad99-3c767ca8366b
TCGA-CR-7372-01A-11D-2012-08	HNSC	9032c525-9bed-47f9-b9f2-ecce4593ea37
TCGA-CR-7373-01A-11D-2012-08	HNSC	9b1f5f6d-503c-4933-944a-b4fd1cc3fa93
TCGA-CR-7374-01A-11D-2012-08	HNSC	2cf33b63-464e-49a0-88f0-6a6d5b0393c4
TCGA-CR-7376-01A-11D-2129-08	HNSC	a6b11f68-79da-4542-818d-f404116c0bf8
TCGA-CR-7377-01A-11D-2012-08	HNSC	93e4eb9a-7643-411b-be90-94b801f23566
TCGA-CR-7379-01A-11D-2012-08	HNSC	8cc45c01-a363-4151-9ea0-32c404b79da4
TCGA-CR-7380-01A-11D-2012-08	HNSC	ac968fdd-970b-41fc-99f7-5670c741bc06
TCGA-CR-7382-01A-11D-2129-08	HNSC	fdde6828-b9f4-4648-a86b-157c5d46abb2
TCGA-CR-7383-01A-11D-2129-08	HNSC	203629ed-2791-4e22-a9da-be647b0cdef5
TCGA-CR-7385-01A-11D-2012-08	HNSC	2c00b622-c4a4-4862-b14a-a97b7261f46f
TCGA-CR-7386-01A-11D-2012-08	HNSC	dac99486-00bc-41ad-92b4-8bed1a28b122
TCGA-CR-7388-01A-11D-2012-08	HNSC	3eddb2ad-6c75-4ae7-9d27-8ec0e7b4aa55
TCGA-CR-7389-01A-11D-2012-08	HNSC	37149937-8131-4dbf-916b-d599d203eba7
TCGA-CR-7390-01A-11D-2012-08	HNSC	714399af-e425-43bb-a82a-b62ca6fd735d
TCGA-CR-7391-01A-11D-2012-08	HNSC	7236609c-34dd-425a-b882-2dff36983f7b
TCGA-CR-7392-01A-11D-2012-08	HNSC	0616d3e5-9641-4329-a65a-19f4c6918e1c
TCGA-CR-7393-01A-11D-2012-08	HNSC	f59ef1d2-2fc0-44a0-9d2f-c4efd9e79f5d
TCGA-CR-7394-01A-11D-2012-08	HNSC	1fe9a612-4c9a-432d-b175-e1d8bdbc7c56
TCGA-CR-7395-01A-11D-2012-08	HNSC	bd0b1b16-ee20-48e5-be11-70eac9c15630
TCGA-CR-7397-01A-11D-2012-08	HNSC	b93863c2-4657-4ca2-8fce-094fe5df163a
TCGA-CR-7398-01A-11D-2012-08	HNSC	12c391dc-3138-4e73-bdc7-b06512dd0fa7

2019203664 24 May 2019

TCGA-CR-7399-01A-11D-2012-08	HNSC	0a76ba15-f6e5-484f-8a52-9be8351ebdb7
TCGA-CR-7401-01A-11D-2012-08	HNSC	f8d6968c-2648-4dcf-a0da-77e46878581c
TCGA-CR-7402-01A-11D-2012-08	HNSC	015b1cc4-6fa5-43c1-9444-4a1af7663f7e
TCGA-CR-7404-01A-11D-2129-08	HNSC	1c1a8920-9163-4d56-a982-61c4e792cee7
TCGA-CV-5430-01A-02D-1683-08	HNSC	4dfcbe35-9e78-4629-8a00-96fee7062d1e
TCGA-CV-5431-01A-01D-1512-08	HNSC	f1a234f0-8890-4cf3-891f-c7a7423b1e75
TCGA-CV-5432-01A-02D-1683-08	HNSC	91e9ac70-5524-4b13-9d53-7cec52b38ea5
TCGA-CV-5434-01A-01D-1683-08	HNSC	69ef7b45-cd0e-4d59-a0ee-35a8c830120c
TCGA-CV-5435-01A-01D-1683-08	HNSC	ec0a719b-3c3a-4797-9ec5-90d3474da727
TCGA-CV-5436-01A-01D-1512-08	HNSC	34dc613e-e4b4-4897-ac4b-13ff46e46d7e
TCGA-CV-5439-01A-01D-1683-08	HNSC	42a06486-b084-4497-8fe0-a8cff194e020
TCGA-CV-5440-01A-01D-1512-08	HNSC	5f5ba5a9-8089-4fe7-92e3-6c31c5fb32d4
TCGA-CV-5441-01A-01D-1512-08	HNSC	f57f2873-a4ae-4fc0-9d4c-e1f4ef47482e
TCGA-CV-5442-01A-01D-1512-08	HNSC	4d42594f-c1f4-45ed-8bd2-7701f914d33c
TCGA-CV-5443-01A-01D-1512-08	HNSC	9d279797-4464-4ef5-8858-640978ccc258
TCGA-CV-5444-01A-02D-1512-08	HNSC	cf975479-131b-4b37-927e-cacb1f13e62d
TCGA-CV-5966-01A-11D-1683-08	HNSC	24ad5336-f5ee-49c0-a176-48411285fbe8
TCGA-CV-5970-01A-11D-1683-08	HNSC	a52dc15f-d06d-46ed-a73e-aa004a2a736a
TCGA-CV-5971-01A-11D-1683-08	HNSC	881a530b-fdd2-4674-b95d-fded0dfce4ff
TCGA-CV-5973-01A-11D-1683-08	HNSC	b848fbad-1eb3-4bc2-9006-2d0ca559cee8
TCGA-CV-5976-01A-11D-1683-08	HNSC	7b643ce3-43bc-4a14-942a-0d6fcffa0312
TCGA-CV-5977-01A-11D-1683-08	HNSC	81f3c96a-54bb-4629-a64e-7c8dae66e11a
TCGA-CV-5978-01A-11D-1683-08	HNSC	791d4f3f-90e0-4fa5-9671-9b5f04ed3eca
TCGA-CV-5979-01A-11D-1683-08	HNSC	c2c31b58-c5b3-4fc3-be99-b978d2961f86
TCGA-CV-6003-01A-11D-1683-08	HNSC	9a040a5e-3d2b-433a-9786-7c26b433c0c2
TCGA-CV-6433-01A-11D-1683-08	HNSC	16b220fa-a554-43c9-85b0-315331e5ba6e
TCGA-CV-6436-01A-11D-1683-08	HNSC	a5214457-3a86-4b29-b116-3baaa0aa5099
TCGA-CV-6441-01A-11D-1683-08	HNSC	22b32736-3b91-4542-affa-46fa90819e69
TCGA-CV-6933-01A-11D-1912-08	HNSC	8ef4b02e-4d34-4d58-aa2d-65a7f73982d5
TCGA-CV-6934-01A-11D-1912-08	HNSC	f5abf385-0372-4faa-9558-8bf02381b68b
TCGA-CV-6935-01A-11D-1912-08	HNSC	fdc0ebce-5ba2-4c18-b594-50b33ef6d116
TCGA-CV-6936-01A-11D-1912-08	HNSC	2d4bdd75-d967-40b2-b55d-99e59cc7e125
TCGA-CV-6937-01A-11D-2012-08	HNSC	1c78a20e-150f-4c12-8abe-b941f90e730f
TCGA-CV-6938-01A-11D-1912-08	HNSC	b1dcb76e-b98f-4989-90a2-885e50d8174c
TCGA-CV-6939-01A-11D-1912-08	HNSC	e2e84cc1-2944-489e-be1b-0018a4e723e4
TCGA-CV-6940-01A-11D-1912-08	HNSC	39f2e005-79f9-4c63-a6d6-0b378481a3ba
TCGA-CV-6941-01A-11D-1912-08	HNSC	87071681-0058-4081-91f3-f689a150fc94
TCGA-CV-6942-01A-21D-2012-08	HNSC	c5409f12-e438-4979-b40e-120899c1fa15
TCGA-CV-6943-01A-11D-1912-08	HNSC	4fa37ade-3451-406d-b0bb-e135e1591b70
TCGA-CV-6945-01A-11D-1912-08	HNSC	fcfc9b74-5b8a-45b7-97ca-4e477e941e7c
TCGA-CV-6948-01A-11D-1912-08	HNSC	03eb2650-4b9f-46d2-b09f-378d8e919ae2

2019203664 24 May 2019

TCGA-CV-6950-01A-11D-1912-08	HNSC	4a341860-44fb-493e-bd46-aeb6610842de
TCGA-CV-6951-01A-11D-1912-08	HNSC	9e1bf26c-6a68-44d2-aaa8-9af2f67828aa
TCGA-CV-6952-01A-11D-1912-08	HNSC	2d859062-3655-471e-b3dd-e6ff0671c076
TCGA-CV-6953-01A-11D-1912-08	HNSC	fb79f2be-3dec-4b5a-b5f3-e29e0fb05a98
TCGA-CV-6954-01A-11D-1912-08	HNSC	08f56645-763e-4864-a145-c0136dacd4f5
TCGA-CV-6955-01A-11D-2012-08	HNSC	f2c7fbe1-af36-4c42-b5ae-b9bf1e88fe36
TCGA-CV-6956-01A-21D-2012-08	HNSC	9ccee056-124e-40d5-a07d-c208765d8640
TCGA-CV-6959-01A-11D-1912-08	HNSC	ff4cc4f1-9897-4d04-a3f6-c28a9b928b7a
TCGA-CV-6960-01A-41D-2012-08	HNSC	750da72e-cabd-4b97-8160-8c4e39272b8b
TCGA-CV-6962-01A-11D-1912-08	HNSC	0b2767d9-10b4-4ec4-9437-5a5186e284ca
TCGA-CV-7089-01A-11D-2012-08	HNSC	125ccb76-bf8d-4ce7-a04c-4424d6da0322
TCGA-CV-7090-01A-11D-2012-08	HNSC	5c636e2d-f426-43a9-984d-b4455e4388e5
TCGA-CV-7091-01A-11D-2012-08	HNSC	563c5a89-6dad-467e-b2ea-e07677574a08
TCGA-CV-7095-01A-21D-2012-08	HNSC	e4aba107-a048-46e5-b0aa-901f076b6f61
TCGA-CV-7097-01A-11D-2012-08	HNSC	23336d44-bb79-4361-b661-ce26eae06692
TCGA-CV-7099-01A-41D-2012-08	HNSC	12a04e68-c814-4a18-a469-d7edc76e362d
TCGA-CV-7100-01A-11D-2012-08	HNSC	f21a5e1f-84b8-4e6f-8230-03d31cc7c431
TCGA-CV-7101-01A-11D-2012-08	HNSC	511c3fa8-476b-4ee8-8e93-1ab46bc40dbe
TCGA-CV-7102-01A-11D-2012-08	HNSC	eda5514f-3aa1-447c-ad07-55ec307c26e3
TCGA-CV-7103-01A-21D-2012-08	HNSC	e04f3556-ae16-410d-bc03-1057ae308329
TCGA-CV-7104-01A-11D-2012-08	HNSC	4f429401-f71e-4908-9663-2e66bacbebdd
TCGA-CV-7177-01A-11D-2012-08	HNSC	c984165c-88ea-4840-a980-be818db16820
TCGA-CV-7178-01A-21D-2012-08	HNSC	3f30774f-2b8c-4057-abd1-a9dd1e49ec78
TCGA-CV-7180-01A-11D-2012-08	HNSC	4233a363-ba28-495c-8590-644199c33d64
TCGA-CV-7183-01A-11D-2012-08	HNSC	172e7b30-829e-40b2-976e-4971cd1724a9
TCGA-CV-7235-01A-11D-2012-08	HNSC	1758147b-cb09-430b-a8cb-6a144744a79f
TCGA-CV-7236-01A-11D-2012-08	HNSC	dc220a9d-1f16-4fe3-8196-d837a909f038
TCGA-CV-7238-01A-11D-2012-08	HNSC	e9619e49-7185-4158-9e8b-45d446960b60
TCGA-CV-7242-01A-11D-2012-08	HNSC	9e07a1bc-f7c7-4cb4-b3b1-92162a79de0e
TCGA-CV-7243-01A-11D-2012-08	HNSC	bc6a2b7c-8a6c-4084-8551-8d1db9072ec2
TCGA-CV-7245-01A-11D-2012-08	HNSC	56291b3c-595c-4388-a264-9037a48401d8
TCGA-CV-7247-01A-11D-2012-08	HNSC	b0ce56d2-8e2b-42b4-ac59-d37ba5a7a2c3
TCGA-CV-7248-01A-11D-2012-08	HNSC	8ffc7f9d-16da-4cff-b845-f2ff8df87569
TCGA-CV-7250-01A-11D-2012-08	HNSC	14516d2b-47dc-4768-977b-bc3c1fe93722
TCGA-CV-7252-01A-11D-2012-08	HNSC	9692c6b2-ce97-4c92-a0dd-f27d01a94e6e
TCGA-CV-7253-01A-11D-2012-08	HNSC	d501a7e5-70e7-4f80-851a-efe8859d603a
TCGA-CV-7254-01A-11D-2012-08	HNSC	fd22e861-571e-44da-82b6-b128e07d1963
TCGA-CV-7255-01A-11D-2012-08	HNSC	4dedba61-e137-4ae4-8312-94231e3b1d16
TCGA-CV-7261-01A-11D-2012-08	HNSC	9fa7bc79-d05b-41da-8bcc-8d5ad4451b0c
TCGA-CV-7263-01A-11D-2012-08	HNSC	19a07472-c8b9-4a34-b2cb-11ace35e7903
TCGA-CV-7406-01A-11D-2078-08	HNSC	8c9effa8-acb6-4db0-874a-8f0df386924c

2019203664 24 May 2019

TCGA-CV-7407-01A-11D-2078-08	HNSC	94631dc8-6dcb-49ed-bb68-e1a57a65f1cb
TCGA-CV-7409-01A-31D-2229-08	HNSC	47fa56f1-0802-403a-a644-913f1a0fdeca
TCGA-CV-7410-01A-21D-2078-08	HNSC	b89c4f94-b07c-485b-95ba-ffe815616d78
TCGA-CV-7411-01A-11D-2078-08	HNSC	790e387e-9e87-48d0-bc9d-2bc92f20abc5
TCGA-CV-7413-01A-11D-2078-08	HNSC	be482a19-0de0-4e60-a831-9ebe8545a6f3
TCGA-CV-7414-01A-11D-2078-08	HNSC	7137f980-5301-4b18-9664-d887eaced75e
TCGA-CV-7415-01A-11D-2078-08	HNSC	bb1e4188-130c-4206-8671-d7ce3eb8ee74
TCGA-CV-7418-01A-11D-2078-08	HNSC	25a70d04-f533-4e60-b9fc-e74d600db296
TCGA-CV-7421-01A-11D-2078-08	HNSC	ee675976-b447-48c8-bc67-6878a0d35e07
TCGA-CV-7422-01A-21D-2078-08	HNSC	5eb3f291-082c-48a8-b653-09264342adee
TCGA-CV-7423-01A-11D-2078-08	HNSC	a99653e0-2751-4423-93f7-abcf258c9868
TCGA-CV-7424-01A-11D-2078-08	HNSC	76d5fc22-fd06-43f6-94a8-943a09db5fd6
TCGA-CV-7425-01A-11D-2078-08	HNSC	f8cc6696-91d0-4eba-a765-ef7d044238ce
TCGA-CV-7427-01A-11D-2078-08	HNSC	3fdb4698-4a38-4a81-a403-d1ce5568c225
TCGA-CV-7429-01A-11D-2129-08	HNSC	14b42e59-e519-4efc-8105-6f6b83d33353
TCGA-CV-7430-01A-11D-2129-08	HNSC	29a4027f-4d4f-4133-b40a-3bfab6d2ac9e
TCGA-CV-7432-01A-11D-2129-08	HNSC	60da7e3f-4d9c-4cb3-856d-6cc02e381028
TCGA-CV-7433-01A-11D-2129-08	HNSC	15380da5-6a0b-4649-b21b-ce1ed7d61b67
TCGA-CV-7434-01A-11D-2129-08	HNSC	d64e4e80-e6c6-42c8-8bc6-0fafb6475c51
TCGA-CV-7435-01A-11D-2129-08	HNSC	16b7fd85-3664-4c4a-9a43-48b107dbcf7f
TCGA-CV-7437-01A-21D-2129-08	HNSC	53413980-80cc-4c73-8bb6-31a01d6df86e
TCGA-CV-7438-01A-21D-2129-08	HNSC	6fd3ecf3-e87c-46c3-81f0-11e2f8936d61
TCGA-CV-7440-01A-11D-2129-08	HNSC	901c2ed5-8348-4dd9-a84c-6c0b18d6525e
TCGA-CX-7082-01A-11D-2012-08	HNSC	4c6c96b8-958e-4235-9673-8bf4ce0e6b38
TCGA-CX-7085-01A-21D-2012-08	HNSC	4f6ee10b-246d-49cd-8b60-01dcb175e634
TCGA-CX-7086-01A-11D-2078-08	HNSC	dfcb7c6e-b0f4-4557-9669-4c580d1093a0
TCGA-CX-7219-01A-11D-2012-08	HNSC	83f92af6-60ab-402e-8990-e1060ca3cc4c
TCGA-D6-6515-01A-21D-1870-08	HNSC	15c4d640-884c-4d55-897e-2f68314423fe
TCGA-D6-6516-01A-11D-1870-08	HNSC	5ab94b24-1a1f-4df7-a5c6-b1dce8ee9be5
TCGA-D6-6517-01A-11D-1870-08	HNSC	c553e4a2-cbea-43d6-8937-a48836856b5a
TCGA-D6-6823-01A-11D-1912-08	HNSC	e1f4d8ef-f24a-417b-bf22-c03cdb6b5275
TCGA-D6-6824-01A-11D-1912-08	HNSC	b658aa3f-0812-4812-8254-816d9a4d7c04
TCGA-D6-6825-01A-21D-1912-08	HNSC	01f44db3-84dc-4f96-888d-b0370bf582a5
TCGA-D6-6826-01A-11D-1912-08	HNSC	368030ac-f855-452a-a3d3-3698ab9a00dd
TCGA-D6-6827-01A-11D-1912-08	HNSC	059be8f9-9536-40c0-a751-5fe529a2f01f
TCGA-DQ-5624-01A-01D-1870-08	HNSC	01282192-5bb6-44d6-bbc7-33a42eba416b
TCGA-DQ-5625-01A-01D-1870-08	HNSC	4e042e1d-8604-484a-b229-94b85745a478
TCGA-DQ-5629-01A-01D-1870-08	HNSC	e748f828-0b80-47f3-aa92-fb3b2be0dcc2
TCGA-DQ-5630-01A-01D-1870-08	HNSC	5aa7ff44-d4ff-4163-81db-9f09bec8d5b0
TCGA-DQ-5631-01A-01D-1870-08	HNSC	e389975a-e588-48d4-9ed3-548e8ed9de1c
TCGA-DQ-7588-01A-11D-2078-08	HNSC	6aad9b01-6a99-4f21-955f-7938af25a188

2019203664 24 May 2019

TCGA-DQ-7589-01A-11D-2229-08	HNSC	de34e28e-942b-442b-b745-7f2a0e56f3ff
TCGA-DQ-7590-01A-11D-2229-08	HNSC	5cbcf67-f062-4a03-84ad-dabfbcf14514
TCGA-DQ-7591-01A-11D-2078-08	HNSC	4068a2fc-452d-4b2c-88d8-72d30097527b
TCGA-DQ-7592-01A-11D-2078-08	HNSC	d8e20b3b-2666-4b53-aa85-a5056028df98
TCGA-DQ-7594-01A-11D-2229-08	HNSC	92e689c0-08ab-472b-aecd-6344fedcbbc0
TCGA-DQ-7595-01A-11D-2229-08	HNSC	7d504cd7-09f0-4691-a1b2-55fc7d206439
TCGA-F7-7848-01A-11D-2129-08	HNSC	ba8a3e47-ee55-4c88-b29f-6d161ffae1d0
TCGA-H7-7774-01A-21D-2078-08	HNSC	0eb5b79a-e3be-4b19-aef6-74247986aaf6
TCGA-HD-7229-01A-11D-2012-08	HNSC	26b27991-540f-47f4-95f3-a59a493da593
TCGA-HD-7753-01A-11D-2078-08	HNSC	7dc33525-6f57-4b12-9b72-c9c845296ae3
TCGA-HD-7754-01A-11D-2078-08	HNSC	233ecdc4-0b42-4533-8908-64ac7d3ac33b
TCGA-HD-7831-01A-11D-2129-08	HNSC	ae914215-3b1a-4edb-9f5a-ce4a17154178
TCGA-HD-7832-01A-11D-2129-08	HNSC	374f3e37-87e5-4450-a89f-0bde3981a31e
TCGA-HD-7917-01A-11D-2229-08	HNSC	451948c9-3d16-4771-b006-28b98580db2c
TCGA-HL-7533-01A-11D-2229-08	HNSC	fbf8f4a8-be9e-4713-884d-c80ef662d622
TCGA-IQ-7630-01A-11D-2078-08	HNSC	80442509-c2f0-4047-956e-a3633dfd472b
TCGA-IQ-7631-01A-11D-2078-08	HNSC	b2266f1c-1642-4849-9278-41e827691aa7
TCGA-IQ-7632-01A-11D-2078-08	HNSC	9fcfc377-a153-401c-95b4-8a4569866096
TCGA-A3-3311-01A-01D-0966-08	RCC	9c095b70-9a64-48b0-8a1c-45dd00a70019
TCGA-A3-3316-01A-01D-0966-08	RCC	e1241cff-4071-482e-be5b-adb9c46a480a
TCGA-A3-3317-01A-01D-0966-08	RCC	cd12847f-695b-4b97-9a56-a4a1ddc58ec4
TCGA-A3-3319-01A-01D-0966-08	RCC	a771a7ad-8dfa-46ee-849d-4478798c46a6
TCGA-A3-3320-01A-01D-0966-08	RCC	5c4cc718-d7b5-453c-89d8-186ab0869e68
TCGA-A3-3322-01A	RCC	6f329d07-3308-4c84-9113-2bf000e9be3b
TCGA-A3-3323-01A-01D-0966-08	RCC	21c50574-7496-4be5-b723-1fdb980fb208
TCGA-A3-3326-01A-01D-0966-08	RCC	60ed222b-cd0c-4bc5-acd0-39f207be3289
TCGA-A3-3346-01A-01D-0966-08	RCC	c8a52c11-2278-4f15-80bb-c7115c2cd737
TCGA-A3-3347-01A-02D-1386-10	RCC	2f4a6bd7-16ff-4689-b41d-c5fab87823b
TCGA-A3-3349-01A-01D-1251-10	RCC	c2b257f6-9cb5-4598-89c7-f0b55e24dbb3
TCGA-A3-3357-01A-02D-1421-08	RCC	db6f5ad9-ae6e-4689-b146-f733f8352c54
TCGA-A3-3358-01A-01D-1534-10	RCC	fd42afa7-6f0f-48e8-a947-bb9c9f4770ef
TCGA-A3-3362-01A-02D-1386-10	RCC	03c9042a-0206-4f12-b444-62f435140e8d
TCGA-A3-3363-01A-01D-0966-08	RCC	34dac639-c2e5-447d-99c5-c6a3e15538fe
TCGA-A3-3365-01A	RCC	8bc46a09-7328-42e0-ad97-e557ec81048e
TCGA-A3-3367-01A-02D-1421-08	RCC	83a091b9-35cc-4f3b-9d5f-d699b79ac421
TCGA-A3-3370-01A-02D-1421-08	RCC	21ce7121-87b4-4686-9bf6-aff71d8b2223
TCGA-A3-3372-01A-01D-0966-08	RCC	f9f50073-a1d3-4c52-be78-529bd05cbce4
TCGA-A3-3373-01A-02D-1421-08	RCC	6cbaac72-ca6e-4c4b-a016-1836959344c8
TCGA-A3-3376-01A-02D-1421-08	RCC	31031387-393f-4bf9-ba87-cfe7330afc13
TCGA-A3-3378-01A-01D-0966-08	RCC	f04f3a00-e743-4fed-a0b0-e6a81bdd6ddd
TCGA-A3-3380-01A-01D-0966-08	RCC	269d4e2a-a425-4fde-bb51-5880f7f8b2b9

2019203664 24 May 2019

TCGA-A3-3382-01A-01D-0966-08	RCC	f10e1718-6fb8-4c08-bc28-439f26355cd2
TCGA-A3-3383-01A-01D-0966-08	RCC	2ea06f57-c7fa-4881-b9c0-dd3f9c1c4ca0
TCGA-A3-3385-01A	RCC	f780aef6-1c9c-4167-9f55-48885d6e5874
TCGA-A3-3387-01A-01D-1534-10	RCC	e9e149ff-79e0-48f9-9262-1fbbad865e77
TCGA-AK-3429-01A-02D-1386-10	RCC	fa51dce9-2101-4af7-9280-4bad56b6848e
TCGA-AK-3430-01A	RCC	b16a82ca-2eaf-4b7a-b469-2be4a023fc2a
TCGA-AK-3436-01A-02D-1386-10	RCC	714cd118-7f2b-47a5-83f6-41b20674ad03
TCGA-AK-3444-01A-01D-0966-08	RCC	ea794170-156d-4251-b899-abfd60b213b0
TCGA-AK-3451-01A	RCC	242777f6-a875-4072-9696-8d7f7d718906
TCGA-AK-3455-01A-01D-0966-08	RCC	3fbedea4-a6c4-45a4-a963-dc6ca3f7e0ba
TCGA-AK-3456-01A-02D-1386-10	RCC	d36fe1be-96a5-4001-a95e-d499a6087146
TCGA-AK-3458-01A-01D-1501-10	RCC	0198f3c3-78f2-4c19-90d5-c77b74044ca2
TCGA-AS-3778-01A-01D-0966-08	RCC	7b56e923-2bc5-4368-8e28-42649d3bf169
TCGA-B0-4700-01A-02D-1534-10	RCC	32cb433f-359c-44c3-b2df-d2a64df90175
TCGA-B0-4706-01A-01D-1501-10	RCC	040fdd9b-db76-4357-9aed-77a8cbde058d
TCGA-B0-4710-01A	RCC	6fc8cb4b-1dc0-46b8-ae80-7dbd022c9431
TCGA-B0-4712-01A-01D-1501-10	RCC	032b33f8-ff79-47de-8cb2-d744eab8bd1a
TCGA-B0-4810-01A-01D-1501-10	RCC	e014eeeb-c48e-42bb-a683-93299087a3cf
TCGA-B0-4811-01A-01D-1501-10	RCC	a46182dc-2481-4911-9f6b-9532666f9f8c
TCGA-B0-4815-01A-01D-1501-10	RCC	fe091054-41d3-44fa-86a2-fad3ae58423f
TCGA-B0-4816-01A	RCC	d05c3419-4164-4a69-8b11-ce1f5c29b5d4
TCGA-B0-4818-01A-01D-1501-10	RCC	213bf382-c2ca-45d4-95ae-329e6653620f
TCGA-B0-4823-01A-02D-1421-08	RCC	9f790e7e-3475-4242-82fc-cbdd461ce5ef
TCGA-B0-4827-01A-02D-1421-08	RCC	02f83f9a-4e4d-44f3-8d67-b4fc2d35102b
TCGA-B0-4842-01A-02D-1421-08	RCC	ae765ade-6a06-439c-a1cd-67222a70f44e
TCGA-B0-4852-01A-01D-1501-10	RCC	28dbeb57-c919-4f91-aa3c-7b8f3809011e
TCGA-B0-4945-01A-01D-1421-08	RCC	9fae377f-6c63-4f47-a769-a1396fb15f56
TCGA-B0-5075-01A	RCC	200819c3-826e-49a1-8824-6d4752e6eb6f
TCGA-B0-5077-01A-01D-1462-08	RCC	587f2bd8-952a-4f31-98e7-7654c80b8a99
TCGA-B0-5080-01A-01D-1501-10	RCC	9adf0a63-1d5c-403a-9e78-cb9d62a249a4
TCGA-B0-5081-01A-01D-1462-08	RCC	71a9d096-0e27-4585-b54a-48214d83cd6c
TCGA-B0-5085-01A-01D-1462-08	RCC	a36e36ee-48f3-4674-a9f3-a121a09535c5
TCGA-B0-5088-01A-01D-1462-08	RCC	e56245d6-c681-44e0-9eb2-504bee3e1b32
TCGA-B0-5092-01A-01D-1421-08	RCC	76b9d9e3-6010-4894-8435-debe95a376b5
TCGA-B0-5094-01A-01D-1421-08	RCC	8b910c03-86a9-488d-80b4-1f8c214c2941
TCGA-B0-5095-01A-01D-1421-08	RCC	93c714f8-acea-4550-92fe-aad4aad65ac9
TCGA-B0-5096-01A-01D-1421-08	RCC	261de0a2-6006-4b3b-aac0-37d9b33840aa
TCGA-B0-5097-01A-01D-1421-08	RCC	3af2978e-b892-4817-be05-39f020c06b5e
TCGA-B0-5099-01A-01D-1421-08	RCC	c3150136-ae55-49d0-9212-86728464167d
TCGA-B0-5100-01A-01D-1421-08	RCC	b20bd619-59c9-4e2a-8e64-7bb44eaa75ce
TCGA-B0-5102-01A-01D-1421-08	RCC	abea5e3e-705a-4d2c-b207-1ab43767a19b

2019203664 24 May 2019

TCGA-B0-5104-01A	RCC	ac2cfbde-9d62-49db-9a07-e8166003f10f
TCGA-B0-5106-01A-01D-1421-08	RCC	c0e28603-7204-416d-ba3d-5377a38f677d
TCGA-B0-5107-01A	RCC	4c6f4edb-9a29-48e6-8521-9c5fd2572e2d
TCGA-B0-5108-01A-01D-1421-08	RCC	d1d37af8-d2c3-4825-8e47-1a2e52e3acbb
TCGA-B0-5109-01A-02D-1421-08	RCC	58d6e408-ed00-4e1f-bffa-e73250cfe4a0
TCGA-B0-5110-01A	RCC	38041aeb-60fe-4784-a5d8-fd04b5c0c5f8
TCGA-B0-5113-01A-01D-1421-08	RCC	64b234e0-74f6-453f-b5cb-280e01fba09b
TCGA-B0-5115-01A-01D-1421-08	RCC	f122b61c-d537-4456-84e8-54e541eec531
TCGA-B0-5116-01A	RCC	97421d06-b199-4246-b2da-80a9ba313335
TCGA-B0-5119-01A-02D-1421-08	RCC	414d47c7-41bb-4c83-8cdf-703fa0a46f01
TCGA-B0-5120-01A-01D-1421-08	RCC	6ce58fbc-6742-4ade-84b0-cd025266e030
TCGA-B0-5121-01A-02D-1421-08	RCC	a2751cb2-8545-490c-92d9-edb9775d32b8
TCGA-B0-5399-01A	RCC	a1dddbed-c780-412a-b563-914f71e5c75d
TCGA-B0-5400-01A-01D-1501-10	RCC	e7128330-77b1-48be-b9f0-be986aa63ea8
TCGA-B0-5402-01A-01D-1501-10	RCC	ca62bea0-a008-481e-8a91-d0f3a9598255
TCGA-B0-5691-01A-11D-1534-10	RCC	ac2e1d29-e239-4dab-9d81-77c8d45970eb
TCGA-B0-5692-01A-11D-1534-10	RCC	1af40135-8357-40b7-b711-478633a70f97
TCGA-B0-5693-01A-11D-1534-10	RCC	be92ee16-6288-46c0-aaa7-7a27020cd7ca
TCGA-B0-5694-01A-11D-1534-10	RCC	6edbaa05-b935-4f82-b070-8fc80ea6b609
TCGA-B0-5695-01A	RCC	86e4862c-7405-40b5-b73f-be0c6c52ea6d
TCGA-B0-5696-01A-11D-1534-10	RCC	48b270af-07f2-4cb5-ace2-e2676ffaccd9
TCGA-B0-5697-01A-11D-1534-10	RCC	9ca4e638-5a95-4eeb-bfc4-257e8ea8fa66
TCGA-B0-5698-01A-11D-1669-08	RCC	2ddf2fa6-7871-49fb-be2c-8fce6f8e41ed
TCGA-B0-5699-01A	RCC	086554a9-2172-43a7-9f52-aab7d0888429
TCGA-B0-5701-01A-11D-1534-10	RCC	0e1c563a-ee60-478b-9286-ed90e7561892
TCGA-B0-5702-01A-11D-1534-10	RCC	780b3f3e-1c49-40de-9131-65c4df9ebba6
TCGA-B0-5703-01A-11D-1534-10	RCC	963400a2-d939-41a5-8c42-9fc3a04b8362
TCGA-B0-5705-01A-11D-1534-10	RCC	d3095df5-5466-4b98-9f6d-f8ae8916ccca
TCGA-B0-5706-01A-11D-1534-10	RCC	b60cf910-2d2e-483a-a9de-ce1e5f8d3825
TCGA-B0-5707-01A-11D-1534-10	RCC	eb2f9f38-bce2-4746-a3c8-40abc3379b32
TCGA-B0-5709-01A-11D-1534-10	RCC	bfeacbe-7148-4642-b69a-b908a248f328
TCGA-B0-5710-01A-11D-1669-08	RCC	12f1e370-c269-4b95-a89b-a1f3ae42e876
TCGA-B0-5711-01A-11D-1669-08	RCC	cf09ae91-5523-494c-8f30-c26f6ba37624
TCGA-B0-5713-01A-11D-1669-08	RCC	2f35dbf4-3223-4550-951b-1409a30ece68
TCGA-B0-5812-01A-11D-1669-08	RCC	6327ce2c-8a24-45b9-9577-7b7d7b603e68
TCGA-B2-3924-01A	RCC	21527594-ed75-4654-9caf-83d31f248e67
TCGA-B2-4098-01A	RCC	6463ae73-a885-4d69-9345-7110ddac0c7e
TCGA-B2-4099-01A	RCC	e242adb8-db67-475e-a0e4-52a622666b12
TCGA-B2-4101-01A	RCC	a9947b6c-dbc7-4ba5-af61-7647e11e2973
TCGA-B4-5377-01A-01D-1501-10	RCC	a615b02d-fd18-47ef-bd66-6dba56de6981
TCGA-B8-4143-01A-01D-1806-10	RCC	bb186c78-1052-48ec-97f4-c94bddf0df72



2019203664 24 May 2019

TCGA-B8-4146-01B-11D-1669-08	RCC	380bdba7-8a12-4136-877a-f54346d2d8a5
TCGA-B8-4148-01A-02D-1386-10	RCC	fe752e2b-e694-4fa9-99d6-46d5bff9e8cf
TCGA-B8-4151-01A-01D-1806-10	RCC	3f847558-8bc7-49b0-899d-2a7b8f0e3d1a
TCGA-B8-4153-01B-11D-1669-08	RCC	a66078d8-a6b2-4dc4-bfa3-def5a2e4504f
TCGA-B8-4154-01A-01D-1251-10	RCC	e48f5c14-4b64-4d4b-8273-bebc74182181
TCGA-B8-4620-01A	RCC	e4ec1484-4f77-4520-9ff5-bc4dc8a0fb15
TCGA-B8-4621-01A	RCC	242a72ad-5968-4bbf-936d-75b398a61b96
TCGA-B8-4622-01A	RCC	1c86e0f6-a019-47a5-8325-bbb82f76488c
TCGA-B8-5158-01A-01D-1421-08	RCC	9d730534-98e7-464e-945c-5964cec5362a
TCGA-B8-5159-01A-01D-1421-08	RCC	ed8a9be1-31c6-40e2-9af2-8abd80d00995
TCGA-B8-5163-01A-01D-1421-08	RCC	903132ef-877f-4207-ba28-2e9dd765c824
TCGA-B8-5164-01A	RCC	471ce542-e85b-4bdb-b365-4562a93ef1e5
TCGA-B8-5165-01A-01D-1421-08	RCC	d1579785-5c42-4bda-9825-15ead235f7f4
TCGA-B8-5545-01A-01D-1669-08	RCC	514d2342-64ba-4c9f-9866-63bdbc26fda3
TCGA-B8-5550-01A	RCC	dafed455-98a2-419a-bebc-f90b731e2813
TCGA-B8-5552-01B-11D-1669-08	RCC	13b52e49-20df-4e39-9dc9-cf8f7c157bd7
TCGA-B8-5553-01A-01D-1534-10	RCC	7c19e63c-770b-4289-aa47-9b2cf261b4ca
TCGA-BP-4161-01A	RCC	154de511-2bba-4959-970b-6a8429f29793
TCGA-BP-4162-01A	RCC	ca4eac28-22c9-48d8-8139-7cda2cfe4ae2
TCGA-BP-4163-01A	RCC	e44de28c-bce0-471d-bd4c-bea710f7c3cc
TCGA-BP-4164-01A	RCC	a8fab76e-ae69-43d6-972b-5837aec668fd
TCGA-BP-4167-01A-02D-1386-10	RCC	79b810e1-4de4-496d-9f70-ab62246e781b
TCGA-BP-4770-01A-01D-1501-10	RCC	aecbc5db-f75a-42d0-a84d-aa0369b08eec
TCGA-BP-4782-01A	RCC	a6c21bf2-dd9b-4243-863e-9d53b056666f
TCGA-BP-4801-01A-02D-1421-08	RCC	d3e62cb1-5ced-42cb-a360-479ee01877aa
TCGA-BP-4960-01A-01D-1462-08	RCC	36d21be3-2f46-47af-84aa-2305f2513aa1
TCGA-BP-4961-01A	RCC	f207131d-8db7-464b-a3e5-44218da1cafc
TCGA-BP-4962-01A-01D-1462-08	RCC	3454a6fe-2547-4531-a0be-cb27c1879e72
TCGA-BP-4963-01A-01D-1462-08	RCC	154bfa5d-0d9a-40c6-a2a5-bde1054702c3
TCGA-BP-4964-01A-01D-1462-08	RCC	5b838251-67f5-4e22-a291-8a9e206d56db
TCGA-BP-4967-01A-01D-1462-08	RCC	75866d14-47d5-4560-a5a0-32ba3e15ac63
TCGA-BP-4968-01A-01D-1462-08	RCC	d777d5ec-4632-446e-aeac-8ae3e5273fe2
TCGA-BP-4970-01A-01D-1462-08	RCC	205e81c6-235a-450f-b1f8-80c518eb3478
TCGA-BP-4971-01A-01D-1462-08	RCC	c07945e8-8133-4237-9d1f-18c023bc9d2c
TCGA-BP-4972-01A-01D-1462-08	RCC	b2da5d39-33f6-4807-9d1d-92b7cef2a8df
TCGA-BP-4973-01A-01D-1462-08	RCC	5db95dcc-97e3-42a5-87dd-75a09b9c164a
TCGA-BP-4974-01A	RCC	a75c92b2-c67b-42b5-a8c2-7eea1b567ed0
TCGA-BP-4975-01A-01D-1462-08	RCC	109d2752-17f8-4b00-a61f-dfd8e2e3ca81
TCGA-BP-4976-01A-01D-1462-08	RCC	95bd81ec-3c06-4c4d-9915-5cc3dd7a7155
TCGA-BP-4977-01A-01D-1462-08	RCC	7c3bf7c1-07d9-4540-9a5e-614fd60b63ec
TCGA-BP-4981-01A-01D-1462-08	RCC	64a1f085-50cc-4129-a617-e0f691a58039

2019203664 24 May 2019

TCGA-BP-4982-01A-01D-1462-08	RCC	84591a73-bed0-4ad5-9acd-8f31acf27af0
TCGA-BP-4983-01A-01D-1462-08	RCC	beaafd9-d5c0-4bc4-b08b-833c3c91c9ae
TCGA-BP-4985-01A-01D-1462-08	RCC	e56acfea-aec6-4102-8fe0-25df396c10ae
TCGA-BP-4986-01A-01D-1462-08	RCC	4465171a-d048-4078-b1ae-021b2c635ff4
TCGA-BP-4987-01A-01D-1462-08	RCC	7924f8ff-8e78-4910-9dc5-db14d5ee7011
TCGA-BP-4988-01A-01D-1462-08	RCC	792c9867-ceed-4520-bbb7-5dabe290664f
TCGA-BP-4989-01A-01D-1462-08	RCC	7096085b-cd5b-4cd1-8957-a6adcf7e818a
TCGA-BP-4991-01A-01D-1462-08	RCC	d54c714e-b1c4-4669-986d-5e13d2fc3cc3
TCGA-BP-4992-01A	RCC	212717dd-25f1-4c76-a648-b8a7d65caecf
TCGA-BP-4993-01A-02D-1421-08	RCC	34315bea-6ef2-42ec-b17e-c73eed40647f
TCGA-BP-4995-01A-01D-1462-08	RCC	93b9afac-e12e-49d2-96ac-274da6581d76
TCGA-BP-4998-01A-01D-1462-08	RCC	e646f930-967b-43a3-bd70-184e5c38efe5
TCGA-BP-4999-01A-01D-1462-08	RCC	86ffb814-7c65-426b-b7b5-7250322c4d01
TCGA-BP-5000-01A-01D-1462-08	RCC	b9816eaa-3c60-4fbf-abd6-6d869ca9cca7
TCGA-BP-5001-01A	RCC	e863bd35-0382-4979-b599-033a06a1f50b
TCGA-BP-5004-01A-01D-1462-08	RCC	e3d82fe4-b491-4172-86da-429cf16508de
TCGA-BP-5006-01A-01D-1462-08	RCC	11fb962b-b4b8-46f4-bde4-3f87309e94f3
TCGA-BP-5007-01A	RCC	a44eb1d6-3b5c-42e8-b17a-d71ffc0503d5
TCGA-BP-5008-01A	RCC	41c094e9-6c23-4993-8d90-338b66efefc1
TCGA-BP-5009-01A-01D-1462-08	RCC	3baa3cdc-c63e-4556-baf1-c3b03175b0fa
TCGA-BP-5010-01A-02D-1421-08	RCC	553cbe18-6dd3-4b34-b7fe-96a6dd2e6943
TCGA-BP-5168-01A-01D-1421-08	RCC	9930560d-22e6-43aa-a6f0-02515f7af8f0
TCGA-BP-5169-01A-01D-1429-08	RCC	3527b21e-972b-4c31-b5de-8c394ce0e500
TCGA-BP-5170-01A-01D-1429-08	RCC	68761b2c-66b9-4adf-9b60-955f79ed0f11
TCGA-BP-5173-01A-01D-1429-08	RCC	3ce0a5fc-09ae-412a-8a5b-56d9a44433aa
TCGA-BP-5174-01A-01D-1429-08	RCC	53b5cf8d-f3cf-4e7e-91ec-b0c907d1c13f
TCGA-BP-5175-01A-01D-1429-08	RCC	30e58a1e-e7db-43ce-a7e8-afd21f4438e
TCGA-BP-5176-01A-01D-1429-08	RCC	607eb48b-1647-4e35-ac60-f6c50341e304
TCGA-BP-5177-01A-01D-1429-08	RCC	ad4cc7e3-c4d1-4cc0-9c93-33b47dadaaae
TCGA-BP-5178-01A-01D-1429-08	RCC	60888dc5-1408-4bfb-bf27-f3e22f5488e4
TCGA-BP-5180-01A-01D-1429-08	RCC	a776bde5-7503-459c-8419-dc0d744a651e
TCGA-BP-5182-01A-01D-1429-08	RCC	00523547-da1c-4bb1-a627-c0946849b376
TCGA-BP-5183-01A-01D-1429-08	RCC	cd4c37c3-95f2-4612-b6a8-9d6d1dfb5fd4
TCGA-BP-5184-01A-01D-1429-08	RCC	ddebed14-f47f-46e6-ac39-c74ed3363211
TCGA-BP-5185-01A-01D-1429-08	RCC	42dc6d82-f52a-4b13-b3bc-c63002b47e98
TCGA-BP-5186-01A-01D-1429-08	RCC	02b98f85-07df-4fb2-b27e-efd368c84ec8
TCGA-BP-5187-01A	RCC	3257e690-9306-434f-b6ac-17da58ab1243
TCGA-BP-5189-01A-02D-1429-08	RCC	ca98342a-65ec-468a-9cc1-44c7d31a67d6
TCGA-BP-5190-01A-01D-1429-08	RCC	5491645b-552c-47a9-b081-e8e508d1df3d
TCGA-BP-5191-01A-01D-1429-08	RCC	64dd8a08-483e-4dce-90b0-64a751fdbebd
TCGA-BP-5192-01A-01D-1429-08	RCC	4db23b76-46dd-4ed9-a168-fee43b2fc7d7

2019203664 24 May 2019

TCGA-BP-5194-01A-02D-1429-08	RCC	5b52c97e-fdd2-4ae2-b036-297feeb1c7e2
TCGA-BP-5195-01A-02D-1429-08	RCC	c2ab2f01-3744-434a-b5b6-0f22599c9a17
TCGA-BP-5196-01A-01D-1429-08	RCC	201bf07d-0be9-442f-ad66-15ea8c7e812d
TCGA-BP-5198-01A-01D-1429-08	RCC	ac66d658-97d4-416b-8028-0077a1c8a01d
TCGA-BP-5199-01A-01D-1429-08	RCC	135f3b77-1474-40d8-87a1-15939136e8cd
TCGA-BP-5200-01A	RCC	e2557bba-b331-40c2-8389-c52324630bca
TCGA-BP-5201-01A-01D-1429-08	RCC	243c77a9-1591-45ac-b048-a5687a77c764
TCGA-BP-5202-01A-02D-1429-08	RCC	acc7214-d441-4a72-a2eb-9f2811c38a3e
TCGA-CJ-4634-01A-02D-1386-10	RCC	59f18fac-c6f8-4cbf-9259-8c22d6ba0c58
TCGA-CJ-4636-01A	RCC	5889076d-0a5f-4c3a-8254-a941df3186f7
TCGA-CJ-4637-01A-02D-1386-10	RCC	b8480571-ee08-4fa1-b509-1331a8fbc075
TCGA-CJ-4638-01A-02D-1386-10	RCC	cbc187b0-fafe-4b1f-9af0-6714942414ab
TCGA-CJ-4639-01A-02D-1386-10	RCC	9df6d1b1-5a09-4082-8ec0-61b12b3c8801
TCGA-CJ-4640-01A-02D-1386-10	RCC	e406036a-eeeb-474e-8c76-0fa8b64225be
TCGA-CJ-4641-01A-02D-1386-10	RCC	c00265ac-c6cc-4349-ac30-e2e44582015a
TCGA-CJ-4643-01A-02D-1386-10	RCC	5e00e420-94fd-4115-9cd9-cef24f6df0eb
TCGA-CJ-4644-01A-02D-1386-10	RCC	2f2888fb-ae20-4347-87dc-f0eeeb9b0d5
TCGA-CJ-4882-01A-02D-1429-08	RCC	b1b7b8e8-cc87-4a52-900a-1f3ef7d449d7
TCGA-CJ-4897-01A-03D-1429-08	RCC	c1331eec-e2df-4924-918b-7e5134e933c2
TCGA-CJ-4899-01A-01D-1462-08	RCC	943ca428-39f6-4ad2-8ca5-220628a6b5bb
TCGA-CJ-4901-01A-01D-1429-08	RCC	a8a8f3ff-0514-4bca-be75-16ad58eb9e72
TCGA-CJ-4902-01A-01D-1429-08	RCC	3ef9ea62-85c4-4261-af23-ecb86f192cdf
TCGA-CJ-4903-01A-01D-1429-08	RCC	3b685193-f1fa-4c1b-949b-bcdb2d1b934c
TCGA-CJ-4904-01A-02D-1429-08	RCC	9bedcded-0c33-4199-bdce-18681595c2d8
TCGA-CJ-4905-01A-02D-1429-08	RCC	22eb9dc5-8d5e-4158-8edc-12ff62a612be
TCGA-CJ-4907-01A-01D-1429-08	RCC	7c69fcb9-4b94-478a-bcb3-6ebd162d9482
TCGA-CJ-4908-01A-01D-1429-08	RCC	dbc5420c-5c60-4d1e-8554-9d2f6e55c502
TCGA-CJ-4912-01A-01D-1429-08	RCC	894ade93-8feb-4f93-a31a-d9e16eb81743
TCGA-CJ-4913-01A-01D-1429-08	RCC	0635f266-c4be-45ea-8347-455ef7ad5648
TCGA-CJ-4916-01A-01D-1429-08	RCC	81b0e02c-069c-4c4b-b56f-79c2ebec9927
TCGA-CJ-4918-01A-01D-1429-08	RCC	2c5d4600-0271-4c03-ab44-239ac19d8b4d
TCGA-CJ-4920-01A-01D-1429-08	RCC	12bf3338-f541-45a9-9fb7-e84931ba5ed8
TCGA-CJ-4923-01A-01D-1429-08	RCC	19171a1a-6483-4bf3-b0b4-8cd441303c55
TCGA-CJ-5671-01A-11D-1534-10	RCC	5b1084bb-3fb2-4f3f-9ca7-7108b0f77994
TCGA-CJ-5672-01A-11D-1534-10	RCC	61497c42-78f2-43d4-b2ab-2b1e655271a8
TCGA-CJ-5675-01A	RCC	26f77108-c3b0-4833-9a1a-df457d7415a9
TCGA-CJ-5676-01A-11D-1534-10	RCC	2e8aa293-650b-4661-b130-8b70f0949b86
TCGA-CJ-5677-01A-11D-1534-10	RCC	70fe0b18-52d1-40f7-b2a3-c808b3009610
TCGA-CJ-5678-01A-11D-1534-10	RCC	d49759a2-d2a9-48ba-9447-e42c9d3d64c7
TCGA-CJ-5679-01A	RCC	17313700-6052-4901-8850-981fead99d6c
TCGA-CJ-5680-01A-11D-1534-10	RCC	2c718814-9d25-49a6-a430-2019071ec0ab

2019203664 24 May 2019

TCGA-CJ-5681-01A-11D-1534-10	RCC	9ae0744a-9bc1-4cd7-b7cf-c6569ed9e4aa
TCGA-CJ-5682-01A-11D-1534-10	RCC	deceb0ba-600f-491a-a207-2e0205ff89d2
TCGA-CJ-5683-01A-11D-1534-10	RCC	b85e29c5-0206-4d65-aa46-179a55c0ceae
TCGA-CJ-5684-01A-11D-1534-10	RCC	24ee4b71-c2e0-44c3-aaeb-3c488cd26ce7
TCGA-CJ-5686-01A-11D-1669-08	RCC	695e2a72-6b97-4fa1-9f57-d7c6e10438ee
TCGA-CJ-6027-01A-11D-1669-08	RCC	b0483455-4cde-408f-b831-17223c03241a
TCGA-CJ-6028-01A-11D-1669-08	RCC	d165717a-cc3d-4533-8194-0029c186f1bb
TCGA-CJ-6030-01A-11D-1669-08	RCC	c904299c-09a8-4a4c-9378-2fee0ac4cd33
TCGA-CJ-6031-01A-11D-1669-08	RCC	a47debc7-700e-4c64-a9b3-1113609a1ddf
TCGA-CJ-6032-01A-11D-1669-08	RCC	8c9823f0-69af-474d-adb7-5ec8ef4e5af7
TCGA-CJ-6033-01A-11D-1669-08	RCC	c7ce9042-f63c-4a93-a82d-f21977bd9bcb
TCGA-CW-5580-01A-01D-1669-08	RCC	6e4ed3ae-aa80-453a-95be-0af96a7bc4e3
TCGA-CW-5581-01A	RCC	22be4bab-231e-4784-aaa9-45ae158a5153
TCGA-CW-5583-01A-02D-1534-10	RCC	2cb6b578-8543-4a12-8331-1721ddc47303
TCGA-CW-5585-01A-01D-1534-10	RCC	bd6d9aa8-d0ef-4810-a43c-eacdd846c44e
TCGA-CW-5591-01A-01D-1534-10	RCC	02ac80cd-caa3-4dbc-9b57-4a324cec0ad4
TCGA-CW-6087-01A-11D-1669-08	RCC	65c23a97-1763-47d5-8648-df24cf0226f3
TCGA-CW-6090-01A-11D-1669-08	RCC	3b2e654a-4c13-4dab-9e18-1445a43af3e6
TCGA-CW-6093-01A-11D-1669-08	RCC	9b1beb37-1ed7-43c0-a532-56df7941111f
TCGA-CZ-4853-01A-01D-1429-08	RCC	bdef62d1-a036-43b4-811b-bf4beab7eca8
TCGA-CZ-4856-01A-02D-1429-08	RCC	85e26450-4cb1-4a91-ad86-a6d44890ee97
TCGA-CZ-4859-01A-02D-1429-08	RCC	82c0b6e4-cb0f-4870-81c9-b45a93d6f5d3
TCGA-CZ-4863-01A-01D-1501-10	RCC	4286d73b-1fb9-41a3-baba-46f23100586a
TCGA-CZ-4865-01A-02D-1501-10	RCC	f8eac30d-1155-44cc-a2ad-95427fecf4bf
TCGA-CZ-4866-01A-01D-1501-10	RCC	a3a06421-7838-4ac2-b5d5-45d2ea651368
TCGA-CZ-5451-01A-01D-1501-10	RCC	b1923d68-1d1e-4b59-b643-09e2c5969efd
TCGA-CZ-5452-01A-01D-1501-10	RCC	96bd68cb-5d8e-4de1-88ca-5f30fbdde036
TCGA-CZ-5453-01A-01D-1501-10	RCC	605079f6-2d6e-4c38-a214-b4c8875dd166
TCGA-CZ-5454-01A-01D-1501-10	RCC	d9fd1928-7b7d-4147-aeff-1618393ba26c
TCGA-CZ-5455-01A	RCC	d6a730ef-3f0d-47c1-977e-5c80647356d4
TCGA-CZ-5456-01A-01D-1501-10	RCC	45d5c746-60e3-4531-8db0-fd648811d45f
TCGA-CZ-5457-01A	RCC	8d54b22b-ee4b-45e0-922e-24e3c20c4c1a
TCGA-CZ-5458-01A-01D-1501-10	RCC	1737382a-a1c9-45e1-b009-a29be1d93749
TCGA-CZ-5459-01A-01D-1501-10	RCC	5711cdaa-7368-4a4f-8639-5df60a2fedac
TCGA-CZ-5460-01A-01D-1501-10	RCC	a6de1551-2a1a-4a43-ba7f-caa436f5f6dd
TCGA-CZ-5461-01A-01D-1501-10	RCC	79feee74-7b14-48d9-9be7-8d7671c79c83
TCGA-CZ-5462-01A-01D-1501-10	RCC	74eed0c6-b3cc-4666-8ef0-194e1bbe1048
TCGA-CZ-5463-01A-01D-1501-10	RCC	3732539b-eb77-485b-81a1-83be956a9a87
TCGA-CZ-5465-01A-01D-1806-10	RCC	062b7e63-bb4e-4eaa-9aa4-f2af44c2ab37
TCGA-CZ-5466-01A	RCC	694ca445-7bac-4216-acf5-e227650ae973
TCGA-CZ-5467-01A-01D-1501-10	RCC	99c640a3-660f-4723-bf82-36fcb3134356

2019203664 24 May 2019

TCGA-CZ-5468-01A-01D-1501-10	RCC	50c6b5a2-cd0e-4adf-b85f-0f9c1847477f
TCGA-CZ-5469-01A-01D-1501-10	RCC	3df654a0-48b0-45ff-bfe1-b5f78f63b30d
TCGA-CZ-5470-01A-01D-1501-10	RCC	e9a7ca9e-c36e-46c1-926f-4a57a0584cb0
TCGA-CZ-5982-01A-11D-1669-08	RCC	2c3c0f78-1c0a-48df-856e-0afbce2b5bceb
TCGA-CZ-5984-01A-11D-1669-08	RCC	89e8e486-0c93-4056-88ed-83fd0d5a7f2c
TCGA-CZ-5985-01A-11D-1669-08	RCC	ad5eae3d-2f73-49d2-be47-5891e7772bc6
TCGA-CZ-5986-01A-11D-1669-08	RCC	0abded91-5a5f-4923-bcf0-7fdda64ae232
TCGA-CZ-5987-01A-11D-1669-08	RCC	84a1a8d2-54c6-4771-9092-27c5f7fc4e5c
TCGA-CZ-5988-01A-11D-1669-08	RCC	668172b3-1e6f-4362-8432-3651925b86a6
TCGA-CZ-5989-01A-11D-1669-08	RCC	852e1614-35c0-4ba7-a29c-e8e2a91aa1b7
TCGA-DV-5565-01A-01D-1534-10	RCC	ee24d408-6043-4ca0-8bde-f29e798cc479
TCGA-DV-5566-01A-01D-1534-10	RCC	39a321cd-dbf-474b-aead-6e69795470e0
TCGA-DV-5568-01A-01D-1534-10	RCC	ecb100d4-24da-40d9-ae1-2901cf3a655a
TCGA-EU-5904-01A-11D-1669-08	RCC	b13e89f1-683b-4261-94a1-e371d797237f
TCGA-EU-5905-01A-11D-1669-08	RCC	091c18b6-bfc2-4353-9eba-ebc46c2c18c5
TCGA-EU-5906-01A-11D-1669-08	RCC	050dc3b7-e560-44f4-a05c-8c792d8467a8
TCGA-EU-5907-01A-11D-1669-08	RCC	5fde36e-05ba-4cce-8303-738f5b04ad16
TCGA-AB-2807-03D-01W-0755-09	AML	3d15bdda-bbb7-4e3d-bdd6-7546d2905e95
TCGA-AB-2809-03D-01W-0755-09	AML	d86f567d-84f8-4a95-af1d-5a26ada92830
TCGA-AB-2814-03D-01W-0755-09	AML	604f0c72-efc7-4868-bc54-79d8f3f3507b
TCGA-AB-2822-03D-01W-0755-09	AML	68b67026-2f30-4839-8579-7a07341b8976
TCGA-AB-2825-03D-01W-0755-09	AML	e6e4b579-9ddf-4fb1-bb65-db8321294852
TCGA-AB-2840-03D-01W-0755-09	AML	cb122429-5b01-4fad-b498-b0342230b567
TCGA-AB-2845-03D-01W-0755-09	AML	98d27719-6f38-433a-ba0a-a14cb32958d8
TCGA-AB-2853-03D-01W-0755-09	AML	9e238bbc-61ba-4966-b30e-ba7ab1a5b11b
TCGA-AB-2858-03D-01W-0755-09	AML	b9dcb0aa-0098-49a9-a0c8-790a06dadea8
TCGA-AB-2863-03D-01W-0755-09	AML	d4ba0ac2-9d98-430b-bb0d-e1bada2d5486
TCGA-AB-2864-03D-01W-0755-09	AML	07f07406-597d-40b7-b218-ef40aad6f0bc
TCGA-AB-2872-03A-01W-0732-08	AML	495c3e6d-76f1-499d-894b-761d50b70566
TCGA-AB-2909-03A-01W-0755-09	AML	39ad6508-a476-4a33-ae8d-6e25fa36369e
TCGA-AB-2912-03A-01W-0732-08	AML	da01cad7-961b-46e2-8a80-9c846694ad5b
TCGA-AB-2918-03A-01W-0745-08	AML	d0833641-77a1-41fd-b635-d216b00d007b
TCGA-AB-2921-03A-01W-0755-09	AML	779697fe-899a-4bfb-a1d3-44a847487b6b
TCGA-AB-2926-03A-01W-0732-08	AML	890ea799-3156-40c3-839c-0c60179006d7
TCGA-AB-2927-03A-01W-0755-09	AML	46bbb19d-2bc9-4f0a-ac4e-cad7327ca142
TCGA-AB-2934-03A-01W-0755-09	AML	7791e140-fe03-44d0-8250-47826ea993df
TCGA-AB-2946-03A-01W-0755-09	AML	f24b41b4-79bf-4736-96c8-83921811bb95
TCGA-AB-2948-03A-01W-0755-09	AML	7b0fb197-8465-430b-9da7-322f2d218729
TCGA-05-4244-01A-01D-1105-08	LUAD	738c514d-ff0f-4220-9326-236119891df5
TCGA-05-4249-01A-01D-1105-08	LUAD	8be717b5-5b65-4631-a175-1f4c063d447e
TCGA-05-4250-01A-01D-1105-08	LUAD	41c4fe84-8beb-4a3a-920c-e74c7edd2182

2019203664 24 May 2019

TCGA-05-4382-01A-01D-1265-08	LUAD	005b918d-e4a9-4971-9588-656a35c33dec
TCGA-05-4384-01A-01D-1753-08	LUAD	4c71b66b-813f-472b-b866-b34b5b9199e7
TCGA-05-4389-01A-01D-1265-08	LUAD	c6f382d4-a522-4333-88b5-be7f55fe80f5
TCGA-05-4390-01A-02D-1753-08	LUAD	d0854b5b-69be-4b84-aa37-ecdd0bc14de9
TCGA-05-4395-01A-01D-1265-08	LUAD	dc45b4de-4c03-4fe4-89e0-d1cf378084b6
TCGA-05-4396-01A-21D-1855-08	LUAD	0176cf1d-0760-4769-a493-277f4bb7585e
TCGA-05-4397-01A-01D-1265-08	LUAD	4b7be121-49af-4a44-95dd-0a487d47228f
TCGA-05-4398-01A-01D-1265-08	LUAD	9e4b2be6-e149-4c22-93e1-512c3c6bbea8
TCGA-05-4402-01A-01D-1265-08	LUAD	75475a84-582d-4949-a428-1e28ad526d8c
TCGA-05-4403-01A-01D-1265-08	LUAD	7e25ac0e-94e4-42f6-ae6f-89d0d21ce09f
TCGA-05-4405-01A-21D-1855-08	LUAD	3ef10eb8-d713-4fda-9e03-bc594b356d77
TCGA-05-4410-01A-21D-1855-08	LUAD	f85d0d42-436b-4251-a7fd-7d0f5fddd397
TCGA-05-4415-01A-22D-1855-08	LUAD	128f52c7-49dc-4a9f-a5bc-1c14684ede9c
TCGA-05-4417-01A-22D-1855-08	LUAD	57e3657d-7a3c-4d80-a2c2-2de0293f5f05
TCGA-05-4418-01A-01D-1265-08	LUAD	b07397ae-592b-4eb4-98b3-7c7e81ecb5e0
TCGA-05-4420-01A-01D-1265-08	LUAD	0536b000-eaf3-4cb2-b46b-8dd9f23c8199
TCGA-05-4422-01A-01D-1265-08	LUAD	a5370f18-e8a9-43d8-9eb8-be678ccd4669
TCGA-05-4424-01A-22D-1855-08	LUAD	fc500ff5-24c8-4965-94da-b4afafafe2dd
TCGA-05-4425-01A-01D-1753-08	LUAD	4a367804-9934-4241-90da-0ba0245564bd
TCGA-05-4426-01A-01D-1265-08	LUAD	117c6aff-8899-48f4-9328-746207d38eff
TCGA-05-4427-01A-21D-1855-08	LUAD	736e0134-8b1a-4ff1-9106-ca09c9812ef6
TCGA-05-4430-01A-02D-1265-08	LUAD	23398531-3f4c-45e6-980b-755165c04974
TCGA-05-4432-01A-01D-1265-08	LUAD	377ab4af-0958-4b8b-ac0c-4cd49c1e4c2e
TCGA-05-4433-01A-22D-1855-08	LUAD	fab4f1ca-1605-4c30-8b3e-badb44eb6580
TCGA-05-4434-01A-01D-1265-08	LUAD	f529778c-5968-4d87-80c0-bd14ba2311d0
TCGA-05-5420-01A-01D-1625-08	LUAD	8371b6a4-ffe4-4fe5-b997-76ece85064a7
TCGA-05-5423-01A-01D-1625-08	LUAD	209d853d-6c50-4223-a572-a90d58ae51e
TCGA-05-5425-01A-02D-1625-08	LUAD	70a3e96b-dd26-419c-9a68-97dea0465d6e
TCGA-05-5428-01A-01D-1625-08	LUAD	7744a93b-0565-4d83-afad-caa02358f258
TCGA-05-5429-01A-01D-1625-08	LUAD	37d0cf1b-1743-4852-8073-372b16b5c17d
TCGA-05-5715-01A-01D-1625-08	LUAD	62fda17b-1de0-4b7e-bd28-a6793bc36d37
TCGA-17-Z000-01A-01W-0746-08	LUAD	ba9d9630-fc6c-4ffb-8464-c1a2ddec6579
TCGA-17-Z001-01A-01W-0746-08	LUAD	d5e77555-9412-4e64-a6aa-65c996e3d521
TCGA-17-Z003-01A-01W-0746-08	LUAD	443d768f-b871-4149-9ef0-2d49bc0d05a1
TCGA-17-Z004-01A-01W-0746-08	LUAD	c1a70a4b-2879-48e8-87e1-b02c57d58705
TCGA-17-Z005-01A-01W-0746-08	LUAD	96b0bb86-6092-47ef-8088-fd0a4f261439
TCGA-17-Z007-01A-01W-0746-08	LUAD	cac5bcd1-f044-4275-89cd-1110d0025537
TCGA-17-Z008-01A-01W-0746-08	LUAD	6b6ddf99-f050-4dfa-85a2-d5a3e3ad56b0
TCGA-17-Z009-01A-01W-0746-08	LUAD	8c5a3460-c1fa-4b7b-9b31-11f9c7b03255
TCGA-17-Z010-01A-01W-0746-08	LUAD	c9fb7916-74d0-4266-b5b8-705018e0e76b
TCGA-17-Z011-01A-01W-0746-08	LUAD	d7495a00-b312-4502-9e1b-9e5f3dbf4b5d

2019203664 24 May 2019

TCGA-17-Z012-01A-01W-0746-08	LUAD	861e9d45-df9a-41a6-9ddf-bc72f85aed80
TCGA-17-Z013-01A-01W-0746-08	LUAD	ee0cbaf2-a0bb-4e58-9e52-5986b5f4f25e
TCGA-17-Z014-01A-01W-0746-08	LUAD	ca24ac3d-4686-4f0c-a47d-0eff92a623b1
TCGA-17-Z015-01A-01W-0746-08	LUAD	770c22ba-b759-433e-8478-b6cf0d685447
TCGA-17-Z016-01A-01W-0746-08	LUAD	39bbd67b-52fd-46e5-98cf-b5632400216d
TCGA-17-Z017-01A-01W-0746-08	LUAD	37049bf1-55cb-44d3-b673-1e270ea835f7
TCGA-17-Z018-01A-01W-0746-08	LUAD	dd1a61eb-8362-41a9-952d-b7e6887457ad
TCGA-17-Z020-01A-01W-0746-08	LUAD	7ea20aa3-68cf-4389-9ace-99d6149d16c1
TCGA-17-Z021-01A-01W-0746-08	LUAD	9394b536-cd08-414b-86a3-c6491f967709
TCGA-17-Z022-01A-01W-0746-08	LUAD	7f07e5b3-bf70-4690-84ba-a9eace798a24
TCGA-17-Z023-01A-01W-0746-08	LUAD	bd72330a-463f-471b-9eba-2f188524e74c
TCGA-17-Z025-01A-01W-0746-08	LUAD	99eab29e-32d3-49d5-aa30-56de8be556e7
TCGA-17-Z026-01A-01W-0746-08	LUAD	bb048ffc-de00-4706-85bb-d052c0fb6496
TCGA-17-Z027-01A-01W-0746-08	LUAD	880452fe-00ed-4732-bbcf-14b55c235e61
TCGA-17-Z028-01A-01W-0746-08	LUAD	1f55fb6e-342a-41e0-9a8e-7c5156c95eaa
TCGA-17-Z030-01A-01W-0746-08	LUAD	e35e27e8-6cc5-495b-9ae8-89f65d94ebed
TCGA-17-Z031-01A-01W-0746-08	LUAD	6516244a-dfd8-4568-a2d2-7556cbea52b1
TCGA-17-Z032-01A-01W-0746-08	LUAD	92bc438b-02c1-4b81-a90a-4a1302786a81
TCGA-17-Z033-01A-01W-0746-08	LUAD	639aea7c-5a38-4641-bf0d-90a9ce8e2980
TCGA-17-Z035-01A-01W-0746-08	LUAD	a4bcb2e-594f-4a89-8b72-8c922a64cdef
TCGA-17-Z036-01A-01W-0746-08	LUAD	374b881a-dbe2-4b4b-bfc0-8431f1aec06c
TCGA-17-Z037-01A-01W-0746-08	LUAD	bffe237d-31b0-4950-a7ab-4ac7047aa3c0
TCGA-17-Z038-01A-01W-0746-08	LUAD	8785c362-1c4d-41da-a29e-5cff21dc2a2e
TCGA-17-Z040-01A-01W-0746-08	LUAD	62d2ca54-b8e0-4907-b75e-cb9786069b52
TCGA-17-Z041-01A-01W-0746-08	LUAD	c0ead7c7-169e-4932-a987-5461611c95e6
TCGA-17-Z042-01A-01W-0746-08	LUAD	3c303c9d-6cda-490d-a64d-21bc40b064f3
TCGA-17-Z043-01A-01W-0746-08	LUAD	577f7267-c568-4002-a153-26c09d1eca97
TCGA-17-Z044-01A-01W-0746-08	LUAD	cb1aaeb8-0c6f-4266-968c-38a3823d85f6
TCGA-17-Z045-01A-01W-0746-08	LUAD	ec7e65c5-7158-427f-8034-8616077da50b
TCGA-17-Z046-01A-01W-0746-08	LUAD	7aac0e3f-39fe-4c9a-9482-50f02f1b919d
TCGA-17-Z047-01A-01W-0747-08	LUAD	2c04cfa8-6e99-46fa-82ad-36fb96e5ffef
TCGA-17-Z048-01A-01W-0746-08	LUAD	8495e150-796b-4e15-9fa6-1fba558d7b10
TCGA-17-Z049-01A-01W-0746-08	LUAD	ac31bcc6-6ccc-43b7-96f2-3ab47050be76
TCGA-17-Z050-01A-01W-0747-08	LUAD	d086dd38-a9e0-466c-b1e5-9a4a879abd55
TCGA-17-Z051-01A-01W-0747-08	LUAD	5584878f-0608-45d9-8e28-29c277bf655f
TCGA-17-Z052-01A-01W-0747-08	LUAD	afdf7c82-2a17-4c73-980c-74ec822dc803
TCGA-17-Z053-01A-01W-0747-08	LUAD	2d422986-6e91-4299-b6cf-4076f3706c83
TCGA-17-Z054-01A-01W-0747-08	LUAD	409dd077-dab9-4f79-9c33-2c3b75b63125
TCGA-17-Z055-01A-01W-0747-08	LUAD	de78326d-3afc-4f29-af7f-1750da544826
TCGA-17-Z056-01A-01W-0747-08	LUAD	e6cb3d63-5a55-4eba-84d2-a25917c7b18e
TCGA-17-Z057-01A-01W-0747-08	LUAD	4236905d-1549-4cbc-b3c6-e62db9ea598b

2019203664 24 May 2019

TCGA-17-Z058-01A-01W-0747-08	LUAD	6b0b1fca-efce-49d6-9f7b-a2c34bb343e9
TCGA-17-Z059-01A-01W-0747-08	LUAD	88ec6fb4-1b81-422e-8204-ef9e8dbf260c
TCGA-17-Z060-01A-01W-0747-08	LUAD	f834dfa4-8d9c-4e0b-861f-a3cc31245237
TCGA-17-Z061-01A-01W-0747-08	LUAD	1eb07e6e-6cf8-45e4-9b5c-1a9a5d38d117
TCGA-17-Z062-01A-01W-0747-08	LUAD	f3280e5f-7d6e-4a18-a5a5-e84b805c9e66
TCGA-35-3615-01A	LUAD	7407d705-6ec6-4143-93d2-eedcf5a22399
TCGA-35-3621-01A-01D-0969-08	LUAD	4a0cc41a-562c-4aea-a7c3-b1186d46cda8
TCGA-35-4122-01A-01D-1105-08	LUAD	408e1cb4-64a8-4801-bf58-3b8183ede851
TCGA-35-4123-01A-01D-1105-08	LUAD	7ccecaee-df27-4f7f-bfcd-e1c59b365711
TCGA-35-5375-01A-01D-1625-08	LUAD	63e76bef-3ef1-445f-b591-649d774729cd
TCGA-38-4625-01A-01D-1553-08	LUAD	6f317d31-c9a4-4345-b5b1-b75776536402
TCGA-38-4626-01A-01D-1553-08	LUAD	85b56ce7-b420-433e-a77d-43ef628d685c
TCGA-38-4627-01A-01D-1553-08	LUAD	abef97da-d7db-495f-b594-fa66577becd6
TCGA-38-4628-01A-01D-1265-08	LUAD	67bc44b7-92cf-4e8f-a7f6-c53bf34a17c6
TCGA-38-4629-01A-02D-1265-08	LUAD	4797f969-5f4d-4681-9fc5-68f25ba8f4d8
TCGA-38-4630-01A-01D-1265-08	LUAD	2b139bb4-5a29-4684-901d-8d966ff79ac2
TCGA-38-4631-01A-01D-1753-08	LUAD	b3ffc36d-b0b8-4ada-a00a-b48890c0162c
TCGA-38-4632-01A-01D-1753-08	LUAD	83519ed1-29e2-4f1b-922c-5779f64178bc
TCGA-38-6178-01A-11D-1753-08	LUAD	7fa467f1-d928-4d81-bd0b-68d67a5c18cf
TCGA-44-2655-01A	LUAD	9fcabda1-ea79-4188-8b3f-7d0fd060a819
TCGA-44-2656-01A	LUAD	5593f581-3d45-4a4a-a525-bfae1f4753a0
TCGA-44-2657-01A-01D-1105-08	LUAD	e3aa9b45-13b9-4b61-a30f-ae3f88466040
TCGA-44-2661-01A-01D-1105-08	LUAD	3c3a2e7c-9aa0-495e-95c7-87f661b9ed92
TCGA-44-2662-01A	LUAD	d2198941-e96f-40bd-9fbe-82886217d5db
TCGA-44-2665-01A	LUAD	a0863fa6-515c-44fa-825f-f9e243f945f1
TCGA-44-2666-01A	LUAD	27a64f32-69c5-4c49-86b4-c8fc923cae08
TCGA-44-2668-01A	LUAD	dd9a6c68-b8b4-4168-9ff9-72a45f20c44f
TCGA-44-3396-01A-01D-1265-08	LUAD	d68b216c-b304-4b30-9af7-eb3a9a1a55ae
TCGA-44-3398-01A-01D-1105-08	LUAD	82284bb3-2dfa-4016-a908-3b5994e00d31
TCGA-44-3918-01A-01D-1105-08	LUAD	7f456c3f-58e3-43f1-9f76-4422451528a5
TCGA-44-3919-01A	LUAD	9de8d353-3442-41d8-8bfe-a08c4975eaca
TCGA-44-4112-01A	LUAD	6c206676-e511-4281-91f5-bfe91b3279a4
TCGA-44-5643-01A-01D-1625-08	LUAD	44286013-ae97-4890-86d3-1163285ac0cd
TCGA-44-5645-01A-01D-1625-08	LUAD	dac33765-0c88-4a51-8389-c042ccb78c83
TCGA-44-6144-01A-11D-1753-08	LUAD	f19575fd-eb9d-429f-96ce-c0e8f4bbe593
TCGA-44-6145-01A-11D-1753-08	LUAD	220dc947-4afc-4485-bcc7-cea046100b4b
TCGA-44-6146-01A-11D-1753-08	LUAD	d5e90162-d7d2-4a7c-89f0-51c2b32c9ef0
TCGA-44-6147-01A-11D-1753-08	LUAD	7b6daa70-492e-4283-b3d2-b26f4e26a8d4
TCGA-44-6148-01A-11D-1753-08	LUAD	9c7b3ac8-1352-49cd-8a8c-df6b19f6fd64
TCGA-44-6774-01A-21D-1855-08	LUAD	f9ccd71b-bece-4693-b953-3e73d1b6c11c
TCGA-44-6775-01A-11D-1855-08	LUAD	7a70a44f-84f3-440a-b898-dc3a0eff748e



2019203664 24 May 2019

TCGA-44-6776-01A-11D-1855-08	LUAD	7d3c5101-fae2-4320-a8a2-a93753375368
TCGA-44-6777-01A-11D-1855-08	LUAD	32a0f0f3-3879-4b96-b9bb-eeab87827f6e
TCGA-44-6778-01A-11D-1855-08	LUAD	903182ad-3145-4fa3-869e-62774aedf86c
TCGA-44-6779-01A-11D-1855-08	LUAD	d6990a90-6a99-490b-a476-5298f0c4e4f2
TCGA-49-4486-01A-01D-1265-08	LUAD	3ac132c3-4889-4dc3-8b3d-0ef98065a858
TCGA-49-4487-01A-21D-1855-08	LUAD	9bd8e303-a81e-4ff8-882b-d46a2f7c55d2
TCGA-49-4488-01A-01D-1753-08	LUAD	3635bb9c-a332-4445-ad81-83cec426dd02
TCGA-49-4490-01A-21D-1855-08	LUAD	940455cf-aa91-432a-bc39-9dfba206e32b
TCGA-49-4494-01A-01D-1265-08	LUAD	136bc973-1908-4767-9b22-d43d522b7c71
TCGA-49-4501-01A-01D-1265-08	LUAD	0c53bb1b-5e6f-44a8-97a0-f89d43e0e789
TCGA-49-4505-01A-01D-1265-08	LUAD	e773a2fe-1d80-492d-bba8-105036a14a92
TCGA-49-4506-01A-01D-1265-08	LUAD	d707f8ad-5ea5-493a-a745-9b5dba64f213
TCGA-49-4507-01A-01D-1265-08	LUAD	562a09a1-b491-45c8-a87d-3c2471353c0d
TCGA-49-4510-01A-01D-1265-08	LUAD	b2c12bff-addd-45a2-ada4-c30ac935809c
TCGA-49-4512-01A-21D-1855-08	LUAD	fa6a60f5-8949-4e01-9435-d3117601627f
TCGA-49-4514-01A-21D-1855-08	LUAD	7751af67-1415-475e-8ec5-66d76f515014
TCGA-49-6742-01A-11D-1855-08	LUAD	49dec0c2-8e75-4f44-a253-82b2ea605890
TCGA-49-6743-01A-11D-1855-08	LUAD	545c9d29-a8e0-4d2d-8552-d27b46f96070
TCGA-49-6744-01A-11D-1855-08	LUAD	bf6ba698-7154-4d7f-b076-24ac2f768696
TCGA-49-6745-01A-11D-1855-08	LUAD	bfb97048-977b-4722-be8f-3dd37370ba30
TCGA-49-6767-01A-11D-1855-08	LUAD	9f82f494-042a-4f00-954c-4761fa25b298
TCGA-50-5044-01A-21D-1855-08	LUAD	ec034986-4bf7-4554-b635-ca6d9c30da28
TCGA-50-5045-01A-01D-1625-08	LUAD	b0d734ad-1222-4bc0-b02b-1d2262b8ac35
TCGA-50-5049-01A-01D-1625-08	LUAD	96358297-0735-4eab-a01c-a6be5d86a3de
TCGA-50-5051-01A-21D-1855-08	LUAD	bb50bc27-fb18-4eee-8785-b8e8b69bcbe6
TCGA-50-5055-01A-01D-1625-08	LUAD	12fe153e-a8f7-49ec-9e0c-f680e2311cf6
TCGA-50-5066-01A-01D-1625-08	LUAD	f5a97315-1906-4774-980e-0879c6ad368e
TCGA-50-5068-01A-01D-1625-08	LUAD	c1efdc48-6ea5-45f0-9fa3-94c42ecf3ab4
TCGA-50-5072-01A-21D-1855-08	LUAD	3c6dcba5-1312-40ca-b589-07f7d88b3477
TCGA-50-5930-01A-11D-1753-08	LUAD	bd3e88b3-b37c-4641-85fa-d8125ba324ca
TCGA-50-5931-01A-11D-1753-08	LUAD	290847c6-c9d4-4a16-a70f-0488e3718f35
TCGA-50-5932-01A-11D-1753-08	LUAD	6726c157-f688-491d-8b56-35628645df89
TCGA-50-5933-01A-11D-1753-08	LUAD	cc3a9cfe-8a14-4fb4-a60f-3ec795c5d7a1
TCGA-50-5935-01A-11D-1753-08	LUAD	9570cd02-3339-4805-855a-74ebe429df96
TCGA-50-5936-01A-11D-1625-08	LUAD	82d380d5-4c07-4cf0-a6e9-7ca9e3fc9a08
TCGA-50-5939-01A-11D-1625-08	LUAD	aa9108d7-5036-4059-ad82-dc64161d5bc3
TCGA-50-5941-01A-11D-1753-08	LUAD	86ef12c0-d5fc-4852-9960-593366e717b4
TCGA-50-5942-01A-21D-1753-08	LUAD	95475c1b-086d-4e09-a871-47d8f76c1a07
TCGA-50-5944-01A-11D-1753-08	LUAD	a314ee0c-694b-4ac8-b572-ff1fbbda4765
TCGA-50-5946-01A-11D-1753-08	LUAD	142d43e8-10e1-4945-a37c-f2824d53b122
TCGA-50-6590-01A-12D-1855-08	LUAD	85de182b-f4ae-41e6-b3fb-f60f46c072e4

2019203664 24 May 2019

TCGA-50-6591-01A-11D-1753-08	LUAD	bf7462a2-394f-4838-bcb6-4d0126fa48b1
TCGA-50-6592-01A-11D-1753-08	LUAD	d0303d05-a937-4a7d-9934-ffa93cc1c5de
TCGA-50-6593-01A-11D-1753-08	LUAD	10e03053-f6e3-42b7-8638-ce58c6e7dfaa
TCGA-50-6594-01A-11D-1753-08	LUAD	e1365c7d-e93e-4478-a8e9-ae2d7ca30bc6
TCGA-50-6595-01A-12D-1855-08	LUAD	9913e506-fc98-467d-8601-89595d0475e8
TCGA-50-6597-01A-11D-1855-08	LUAD	cd0aead5-93a1-4287-8a88-fe6b7b5e3983
TCGA-55-1592-01A	LUAD	e190a9e4-10ae-4060-a071-4b8b73479023
TCGA-55-1594-01A	LUAD	2885d4b3-34a6-421d-b20c-eedad721d10a
TCGA-55-1595-01A-01D-0969-08	LUAD	f1be8e08-5201-49bb-abf7-cedc0eff06d6
TCGA-55-1596-01A	LUAD	9a7a1b22-9df6-438f-ad00-54755c7dbc7c
TCGA-55-5899-01A-11D-1625-08	LUAD	ddaf36f7-7503-4ab4-b7f5-9777c0c1518c
TCGA-55-6543-01A-11D-1753-08	LUAD	ac7ab3b3-eb76-4da9-bfb3-82b90c8d79d6
TCGA-55-6642-01A-11D-1855-08	LUAD	3c756f7c-d1f0-4ab1-9c9f-41d2282af3bf
TCGA-55-6712-01A-11D-1855-08	LUAD	bc6eaf2b-9ccc-4ac7-9b19-204b0ff420a3
TCGA-64-1676-01A	LUAD	4bdf77d2-33cc-46e0-af34-1e66a90a213a
TCGA-64-1677-01A-01W-0928-08	LUAD	559017d8-4b22-4313-abdd-d3526c889d7f
TCGA-64-1678-01A-01W-0928-08	LUAD	42e3b592-b57f-4b18-8f62-e7b0a9c0f1db
TCGA-64-1680-01A	LUAD	0bdb623-cf95-465a-917d-87dfb6a8618e
TCGA-64-5774-01A-01D-1625-08	LUAD	df5957d5-20d3-483e-990b-d6369fb990b8
TCGA-64-5775-01A-01D-1625-08	LUAD	c209d392-7d3a-481c-8cc7-398a6b90290a
TCGA-64-5778-01A-01D-1625-08	LUAD	3c540f87-5981-4b7a-b1ab-30c2056c785e
TCGA-64-5779-01A-01D-1625-08	LUAD	5734711b-52cd-46e6-9c2a-92c0612fee33
TCGA-64-5781-01A-01D-1625-08	LUAD	fb9cfb49-99cf-4f49-8f3d-e25e762eb3ce
TCGA-64-5815-01A-01D-1625-08	LUAD	e800c8d4-786a-4a9d-ace2-2b779336e557
TCGA-67-3770-01A	LUAD	74bcf2d5-fd42-423e-bd96-b2de1b0cf778
TCGA-67-3771-01A	LUAD	b0410cd6-693d-41d6-9dad-d1b1c30bf5cb
TCGA-67-3772-01A-01W-0928-08	LUAD	09226bc4-0202-4405-b3c9-208e8ffb7408
TCGA-67-3773-01A	LUAD	e4cb66f4-e847-40bf-af14-20a3867a1c35
TCGA-67-3774-01A	LUAD	b3585415-9ab9-4614-8b15-8edb66efd1dc
TCGA-67-4679-01B-01D-1753-08	LUAD	341bf21e-abd5-498e-8c49-111782af842c
TCGA-67-6215-01A-11D-1753-08	LUAD	68c2a355-862c-4657-b296-5776ed8447b0
TCGA-67-6216-01A-11D-1753-08	LUAD	6dc6da8c-2ecf-412f-b2c4-74529adb7c0f
TCGA-67-6217-01A-11D-1753-08	LUAD	cb98d825-668f-4b16-a05e-501e1c94f3fe
TCGA-71-6725-01A-11D-1855-08	LUAD	3a146eb4-7b9b-4834-b3d0-eac80f9173ec
TCGA-73-4658-01A-01D-1753-08	LUAD	b11151cf-6976-4812-a77e-1a12f9d1245c
TCGA-73-4659-01A-01D-1265-08	LUAD	13989aec-b1a3-47c2-bc8e-ccf55f8e0c11
TCGA-73-4662-01A-01D-1265-08	LUAD	48262c89-ecac-44c6-9a06-7170b7b41058
TCGA-73-4666-01A-01D-1265-08	LUAD	f49fc77e-03cd-423c-b3e1-18bb19568650
TCGA-73-4668-01A-01D-1265-08	LUAD	0fdcb5e9-ada2-4755-ae02-491037ee9c10
TCGA-73-4670-01A-01D-1265-08	LUAD	2aea0652-17ae-4dfa-9358-206d4f24f02f
TCGA-73-4675-01A-01D-1265-08	LUAD	59dad620-51f8-4c12-8b09-e635fbde126e

2019203664 24 May 2019

TCGA-73-4676-01A-01D-1753-08	LUAD	ff368c6d-fedb-49cc-b519-7726816aff8d
TCGA-73-4677-01A-01D-1265-08	LUAD	a9c03165-d534-425e-8370-d1f557b82fa2
TCGA-75-5122-01A-01D-1753-08	LUAD	e359b24f-7312-432f-b054-68dedc027df2
TCGA-75-5125-01A-01D-1753-08	LUAD	4cee9575-3040-4ff1-bf7e-ca8873860c59
TCGA-75-5126-01A-01D-1753-08	LUAD	1c1ad138-a59e-4f5d-8382-54c585c9298c
TCGA-75-5146-01A-01D-1625-08	LUAD	965a2bb7-6cd4-4309-beba-51ae74b8a980
TCGA-75-5147-01A-01D-1625-08	LUAD	52910a60-bb15-4ba5-9d09-50d8ee6a445b
TCGA-75-6203-01A-11D-1753-08	LUAD	d9cd7f95-07d3-4b87-be83-87340b08d249
TCGA-75-6205-01A-11D-1753-08	LUAD	79c0e183-95aa-4c37-9b15-8567aa87c93a
TCGA-75-6206-01A-11D-1753-08	LUAD	7a5ca29b-85d3-46b1-a710-6dcd3ce821c8
TCGA-75-6207-01A-11D-1753-08	LUAD	5a49e3fd-a47d-4b7d-9485-4238a88f4516
TCGA-75-6211-01A-11D-1753-08	LUAD	d8c9abbe-b112-4019-a6a3-f582df1379ed
TCGA-75-6212-01A-11D-1753-08	LUAD	0f2af4c9-05a8-4c97-ac2d-af9241b4ea64
TCGA-80-5611-01A-01D-1625-08	LUAD	c9bab512-c5c3-4ad3-a9bf-f5258e405966
TCGA-86-6562-01A-11D-1753-08	LUAD	e48dd11b-89ae-4278-8de0-7956423c8609
TCGA-91-6828-01A-11D-1855-08	LUAD	99f819f2-4340-4303-8ff0-fdb03ef0151a
TCGA-91-6829-01A-21D-1855-08	LUAD	443f5b2d-832e-45cf-bca5-3f064ea3bc50
TCGA-91-6831-01A-11D-1855-08	LUAD	1624af6f-05a6-474c-ba49-9754938979c6
TCGA-91-6835-01A-11D-1855-08	LUAD	8120c5eb-2917-4053-a5e5-aad53ff45da9
TCGA-91-6836-01A-21D-1855-08	LUAD	87045814-366d-4e42-97f2-ad341c620c47
TCGA-18-3406-01A-01D-0983-08	LUSC	d3320989-71fd-425b-933e-6e8528a016ed
TCGA-18-3407-01A-01D-0983-08	LUSC	c5b09119-0237-4804-a4f9-b67d676b8674
TCGA-18-3408-01A-01D-0983-08	LUSC	cab7a425-e081-4bae-b666-6cdf8ba4dd70
TCGA-18-3409-01A-01D-0983-08	LUSC	aa733cb0-37a9-4fef-8d40-d57596ce9e51
TCGA-18-3410-01A-01D-0983-08	LUSC	7e6382c3-368a-43a5-9812-c58f54ceba3f
TCGA-18-3411-01A-01D-0983-08	LUSC	6a9cc303-c7fd-4f40-8933-1636dea99252
TCGA-18-3412-01A-01D-0983-08	LUSC	84aca315-8380-4625-887f-a8b3c704c0a9
TCGA-18-3414-01A-01D-0983-08	LUSC	239deee9-2791-4163-b777-fdf8c49c9e33
TCGA-18-3415-01A-01D-0983-08	LUSC	ad0365d1-10b1-41e6-b838-9c5794b9ad42
TCGA-18-3416-01A-01D-0983-08	LUSC	e03577e7-37be-460b-96e8-5f6e0b49b3aa
TCGA-18-3417-01A-01D-1441-08	LUSC	024d8a82-06c5-4b82-9a27-c52bc4fd450a
TCGA-18-3419-01A-01D-0983-08	LUSC	c75ed357-d845-4443-8c9e-a2afa8ed30df
TCGA-18-3421-01A-01D-0983-08	LUSC	9f0e482e-e72d-4c57-b4f7-4580edabd390
TCGA-18-4083-01A-01D-1352-08	LUSC	0b87a82d-096c-4dd7-80c4-b4054fc1eba2
TCGA-18-4086-01A-01D-1352-08	LUSC	9bbdf36b-6804-416f-977d-fce772972bcc
TCGA-18-4721-01A-01D-1441-08	LUSC	d2ab2555-7288-47a4-a80c-bf62d65b67b8
TCGA-18-5592-01A-01D-1632-08	LUSC	1a6da454-8faf-4725-a702-55d29da461a5
TCGA-18-5595-01A-01D-1632-08	LUSC	973b8ed8-2295-4fb0-b857-f4433dfc785a
TCGA-21-1070-01A-01D-1521-08	LUSC	9e300205-b16d-4f40-bf1b-f47410678f6d
TCGA-21-1071-01A-01D-1521-08	LUSC	e01302f9-c5d6-4745-9c5d-d8bb8d278a77
TCGA-21-1076-01A-02D-1521-08	LUSC	504d4cb0-d2dd-420d-82e6-9ec14434a0fc

2019203664 24 May 2019

TCGA-21-1077-01A-01D-1521-08	LUSC	a71d74cb-5b10-4787-a654-7049cbb49a92
TCGA-21-1078-01A-01D-1521-08	LUSC	8cf9b32d-3d6f-4898-8c7a-89511b754021
TCGA-21-1081-01A-01D-1521-08	LUSC	811f7a11-635c-4606-91fd-3729b97ffd8e
TCGA-21-5782-01A-01D-1632-08	LUSC	4c2ad4a0-5d57-4e27-9f35-058b2f205f50
TCGA-21-5784-01A-01D-1632-08	LUSC	f79285af-c364-4ec3-97d3-70a7d9b5800b
TCGA-21-5786-01A-01D-1632-08	LUSC	d7404e0f-d171-419b-97d3-807570aba129
TCGA-21-5787-01A-01D-1632-08	LUSC	7cb79e4b-c1f1-434d-b13b-6c2eb7760ee8
TCGA-22-0944-01A-01D-1521-08	LUSC	818a6f09-a7fd-4cce-8373-adb4bc5bc8c
TCGA-22-1002-01A-01D-1521-08	LUSC	7c7604fe-8321-46cb-ac34-0e7994b8853b
TCGA-22-1011-01A-01D-1521-08	LUSC	c9924f9f-fd86-434c-a83d-393d65272e64
TCGA-22-1012-01A-01D-1521-08	LUSC	3b75368a-d57f-4787-a0ef-3f478c7d22bc
TCGA-22-1016-01A-01D-1521-08	LUSC	935b113e-f5ed-4a07-8e1d-1603daba7f40
TCGA-22-4591-01A-01D-1267-08	LUSC	befb93d4-8653-477b-b5d2-c2832a0e3d92
TCGA-22-4593-01A-21D-1817-08	LUSC	b4a48075-92fd-43ab-95f3-476bcea88d7b
TCGA-22-4595-01A-01D-1267-08	LUSC	7fcf5123-2d1b-4666-9d39-a1aaf63cf954
TCGA-22-4599-01A-01D-1441-08	LUSC	08732b51-8ec8-4888-b0c8-a0cb83181cb9
TCGA-22-4601-01A-01D-1441-08	LUSC	6c05b3f5-65e9-4e7d-9f99-a694006f2ed0
TCGA-22-4604-01A-01D-1267-08	LUSC	db2614fb-109c-4ce1-af4c-f648a0d417fb
TCGA-22-4607-01A-01D-1267-08	LUSC	d8c6bb83-ebdd-4547-9077-3eba5c8bb9f0
TCGA-22-4613-01A-01D-1441-08	LUSC	5d1d538a-57d3-42ec-9fa3-0fad10b0f52f
TCGA-22-5471-01A-01D-1632-08	LUSC	665e98bf-6163-4d18-9665-ba93df9ecf6d
TCGA-22-5472-01A-01D-1632-08	LUSC	be780766-483f-42f5-b0d0-11d23a940156
TCGA-22-5473-01A-01D-1632-08	LUSC	c107ca1d-5e35-470a-8c39-80dc7624e306
TCGA-22-5474-01A-01D-1632-08	LUSC	1eda33fc-80e5-4c5f-8c61-43976ca0106f
TCGA-22-5477-01A-01D-1632-08	LUSC	e7ebc6fb-0926-4c8a-a67b-0c6b9c1ffaba
TCGA-22-5478-01A-01D-1632-08	LUSC	0ac704eb-d722-4c27-bfb4-fea6ca7af240
TCGA-22-5480-01A-01D-1632-08	LUSC	24e426fb-219a-4a4d-a45c-c9b0896d0e88
TCGA-22-5482-01A-01D-1632-08	LUSC	b57c316e-1cae-4286-bdbb-8b65c020b3fa
TCGA-22-5485-01A-01D-1632-08	LUSC	448af8b4-e071-48b0-a65b-b4ad17afdc0c
TCGA-22-5489-01A-01D-1632-08	LUSC	c4eb6681-7ec3-4688-b06a-c47a0043f3fb
TCGA-22-5491-01A-01D-1632-08	LUSC	ed4b5a8c-1dae-41a3-8a2a-f54fa51be4b8
TCGA-22-5492-01A-01D-1632-08	LUSC	abc94013-71f5-4ac6-88a4-01b4ef9f9d2f
TCGA-33-4532-01A-01D-1267-08	LUSC	c8baeba2-2a73-41d7-9226-b89a8f42e18f
TCGA-33-4533-01A-01D-1267-08	LUSC	52b8c7c1-2cfe-410d-a738-1dec43109e24
TCGA-33-4538-01A-01D-1267-08	LUSC	e04814f8-a51f-4b6b-a4e9-bd8d2291817c
TCGA-33-4547-01A-01D-1267-08	LUSC	7e622fc2-06c5-4686-a885-e407725c2f08
TCGA-33-4566-01A-01D-1441-08	LUSC	ddd84ea3-dd5e-4f95-97c3-84c107c19cad
TCGA-33-4582-01A-01D-1441-08	LUSC	4cb06585-62f9-4aae-969a-2085b4d514c3
TCGA-33-4583-01A-01D-1441-08	LUSC	fb901997-6e46-436f-ad34-74aad344245
TCGA-33-4586-01A-01D-1441-08	LUSC	e6bf4288-9fdd-4c56-b6d2-fa2f5ee542b6
TCGA-33-6737-01A-11D-1817-08	LUSC	3b21ce38-16c6-4c68-9104-fa11f1b619b1

2019203664 24 May 2019

TCGA-34-2596-01A-01D-1522-08	LUSC	66e35f68-f4db-46ee-876e-e770ea616ef3
TCGA-34-2600-01A-01D-1522-08	LUSC	167e0f4e-e7d3-4942-885a-cf06419bbe6d
TCGA-34-2608-01A-02D-1522-08	LUSC	3c90209b-b6f6-40b2-a374-6cd37d6d3895
TCGA-34-5231-01A-21D-1817-08	LUSC	c9862ed2-4ba6-434d-a205-b1bda292d218
TCGA-34-5232-01A-21D-1817-08	LUSC	f32fff2f-0bbf-475f-b088-3f1699203c31
TCGA-34-5234-01A-01D-1632-08	LUSC	7b19ae84-2cab-47e7-87df-46c497da17e0
TCGA-34-5236-01A-21D-1817-08	LUSC	46cb2de7-bbe1-4444-b17e-4c5677a05249
TCGA-34-5239-01A-21D-1817-08	LUSC	6e596912-2146-4c4f-97b6-70b610f5d4b4
TCGA-34-5240-01A-01D-1441-08	LUSC	4c3840df-9824-40db-879e-6d24adc8c155
TCGA-34-5241-01A-01D-1441-08	LUSC	0bcdbc37-cde8-47df-9184-621b2b47da5b
TCGA-34-5927-01A-11D-1817-08	LUSC	d717b13a-e487-4cad-9aae-4b0d649236c4
TCGA-34-5928-01A-11D-1817-08	LUSC	9e2d032e-f982-44fc-b6e0-3be82f029689
TCGA-34-5929-01A-11D-1817-08	LUSC	a25de54e-c13d-4973-864a-e307fbc7324a
TCGA-37-3783-01A-01D-1267-08	LUSC	711e9b21-bd8c-4058-a0ce-5ff4dc23b527
TCGA-37-3789-01A-01D-0983-08	LUSC	d732196f-ef85-43ea-aac7-7c9060bf19c5
TCGA-37-4133-01A-01D-1352-08	LUSC	a678cc49-9009-4027-826f-e17f4533538d
TCGA-37-4135-01A-01D-1352-08	LUSC	754dda66-fceb-4f63-bc99-c98aaa86b0c2
TCGA-37-4141-01A-02D-1352-08	LUSC	3d4f4555-d71a-4c7d-8667-c42dcc20c076
TCGA-37-5819-01A-01D-1632-08	LUSC	edf2a2c0-3829-4da2-8960-598fbd5c4c07
TCGA-39-5016-01A-01D-1441-08	LUSC	d63a0a46-7676-40f5-8e03-b8317d243c73
TCGA-39-5019-01A-01D-1817-08	LUSC	6aecdd71e-84f1-4b4d-bff6-ede33026f58b
TCGA-39-5021-01A-01D-1441-08	LUSC	4d8b4c6f-e6eb-4799-b64d-119afc691e3d
TCGA-39-5022-01A-21D-1817-08	LUSC	f60928ab-0cb1-4483-8d61-48a5333defbf
TCGA-39-5024-01A-21D-1817-08	LUSC	388478e9-8c1f-43f8-88c4-811bf3cc2500
TCGA-39-5027-01A-21D-1817-08	LUSC	32c14926-b510-4714-90b2-b0bd68569cd4
TCGA-39-5028-01A-01D-1441-08	LUSC	015b9329-ecf2-4410-b7b6-f9313b5d2adb
TCGA-39-5029-01A-01D-1441-08	LUSC	aa02c83c-7ef0-400d-bd8d-729dacda6352
TCGA-39-5030-01A-01D-1441-08	LUSC	9e7b63f2-6080-4bb0-b45d-a0d40dffcb0
TCGA-39-5031-01A-01D-1441-08	LUSC	3eab4096-8e8e-459d-a2bb-6ef03f414315
TCGA-39-5035-01A-01D-1441-08	LUSC	035fe73e-56b4-4afe-b70e-dd3c34027f2d
TCGA-39-5036-01A-01D-1441-08	LUSC	a1aa5fba-f179-4777-8d49-345a366d12fa
TCGA-39-5037-01A-01D-1441-08	LUSC	825bd82c-f8f8-4776-a7f5-713b3a574955
TCGA-39-5039-01A-01D-1441-08	LUSC	0c14e914-abd4-4406-be82-a810b10a1320
TCGA-43-2578-01A-01D-1522-08	LUSC	7ce90b30-d372-4edb-9807-b71cb5eb4cb7
TCGA-43-3394-01A-01D-0983-08	LUSC	bb72e789-f8ad-4ab5-805b-a9ac21cef0e3
TCGA-43-3920-01A-01D-0983-08	LUSC	a97333f4-d289-493f-8dff-88e52719fa86
TCGA-43-5668-01A-01D-1632-08	LUSC	f01dfe80-ae9-44f6-b32d-3591fbc3c0f5
TCGA-43-6143-01A-11D-1817-08	LUSC	3874253f-7168-4cd6-b1d6-f426fa207313
TCGA-43-6647-01A-11D-1817-08	LUSC	90b97948-26f7-4431-be89-af8c432bae0
TCGA-43-6770-01A-11D-1817-08	LUSC	404ca8c2-f1bb-4749-8abd-87f491a8111c
TCGA-43-6771-01A-11D-1817-08	LUSC	20735861-1f84-4141-a467-f598108e1e41

2019203664 24 May 2019

TCGA-46-3765-01A-01D-0983-08	LUSC	6c4bb09f-46c8-4a42-bf4f-8bad5316603d
TCGA-46-3766-01A-01D-0983-08	LUSC	0a691892-2209-4f3c-ab16-c2560e4928b4
TCGA-46-3767-01A-01D-0983-08	LUSC	db4ea3ec-e926-4e75-a97b-a527c101b3b9
TCGA-46-3768-01A-01D-0983-08	LUSC	30666313-cc29-4fce-8308-b04fb932083c
TCGA-46-3769-01A-01D-0983-08	LUSC	108a1360-a545-4573-a775-49b3420814e2
TCGA-46-6025-01A-11D-1817-08	LUSC	767a9ae0-2aa4-467b-b9c3-fb3bf701b642
TCGA-46-6026-01A-11D-1817-08	LUSC	42a4a60c-257e-4bf6-a9ba-6f162dbca94a
TCGA-51-4079-01A-01D-1458-08	LUSC	0a43aade-225c-4a29-b1d8-6b930eb8a1db
TCGA-51-4080-01A-01D-1458-08	LUSC	2498ada2-b8d3-4220-8283-45af67a8119a
TCGA-51-4081-01A-01D-1458-08	LUSC	1492c429-1041-4d86-9358-c9b9babd1401
TCGA-56-1622-01A-01D-1521-08	LUSC	0bbc7ede-5022-4084-925c-d65baaf7abc2
TCGA-56-5897-01A-11D-1632-08	LUSC	056acb55-f3ba-4ce0-9735-3cfe6516df55
TCGA-56-5898-01A-11D-1632-08	LUSC	aaf47efe-4a0a-40d1-b70f-9c9168cbdae0
TCGA-56-6545-01A-11D-1817-08	LUSC	16756a08-8308-4ad3-9e21-2cea0cd7028e
TCGA-56-6546-01A-11D-1817-08	LUSC	87e71949-5bd9-458c-95f7-4b19882c2b4f
TCGA-60-2698-01A-01D-1522-08	LUSC	2045c788-9ea8-4ea5-a5e3-65fc16a62adb
TCGA-60-2707-01A-01D-1522-08	LUSC	5d1fa470-2789-4576-9743-0362af682c1d
TCGA-60-2708-01A-01D-1522-08	LUSC	a371189b-5808-4408-824e-8dacec925cc5
TCGA-60-2709-01A-21D-1817-08	LUSC	4f321c92-ae27-4253-bd8b-4505ba8c7dc4
TCGA-60-2710-01A-01D-1522-08	LUSC	faecb1fe-b4ef-434d-818c-81ad2167dd25
TCGA-60-2711-01A-01D-1522-08	LUSC	2ed85cc9-31bc-4cea-9e54-13b7c0e645fa
TCGA-60-2712-01A-01D-1522-08	LUSC	6662dd1b-3e4f-4b7a-b603-cfa7fd92fc30
TCGA-60-2713-01A-01D-1522-08	LUSC	79eb7bba-f0d8-462c-add7-20a2fb7843e1
TCGA-60-2715-01A-01D-1522-08	LUSC	8e05a30d-2177-45e0-90fd-8c5961268c39
TCGA-60-2719-01A-01D-1522-08	LUSC	ee6cc68e-8d2a-41ee-82c6-0fecdf7e6259
TCGA-60-2720-01A-01D-1522-08	LUSC	3b435ddf-a496-40a2-82e8-6b10391aae5d
TCGA-60-2721-01A-01D-1522-08	LUSC	8defff62-9395-47cb-bb19-4b8487d9ea8e
TCGA-60-2722-01A-01D-1522-08	LUSC	eb955f72-83bf-4635-a7ed-89e4d66e08f4
TCGA-60-2723-01A-01D-1522-08	LUSC	8a6aa45a-ef6d-4005-b7c9-e15240dc6dd4
TCGA-60-2724-01A-01D-1522-08	LUSC	387c6519-6529-4074-a5ab-00f8052a5732
TCGA-60-2725-01A-01D-1267-08	LUSC	f3ed705b-e5aa-4756-9794-e4b85303693a
TCGA-60-2726-01A-01D-1522-08	LUSC	a96eddfc-3afb-4bf8-a440-c91778113fbd
TCGA-63-5128-01A-01D-1441-08	LUSC	d3b9b51e-eeee-4355-829d-ee35bdd2cf5b
TCGA-63-5131-01A-01D-1441-08	LUSC	b290a86e-22da-4f10-a421-2616bb47bc1b
TCGA-63-6202-01A-11D-1817-08	LUSC	a3c568a6-0c43-47a7-a35a-3225fedeeb44
TCGA-66-2727-01A-01D-0983-08	LUSC	c2b2c909-1461-42ce-8fd9-736147dcacd8
TCGA-66-2734-01A-01D-0983-08	LUSC	9f7a24a2-10e2-4039-ad27-13d7ec28ff36
TCGA-66-2742-01A-01D-0983-08	LUSC	07047a99-45bd-4df6-ad6f-934a48e8e213
TCGA-66-2744-01A-01D-0983-08	LUSC	43be1a37-b18e-4e96-89e6-ed6ee1d8e65a
TCGA-66-2754-01A-01D-0983-08	LUSC	c34a64c8-3746-44f8-a7ee-77f502b6256c
TCGA-66-2755-01A-01D-1522-08	LUSC	177d64a9-65dc-4aa1-8774-bd8208e40f04

2019203664 24 May 2019

TCGA-66-2756-01A-01D-1522-08	LUSC	472c95e6-eccb-4988-be16-fdace73b2ed8
TCGA-66-2757-01A-01D-1522-08	LUSC	1886dba0-4662-4342-84ac-96af0beb2393
TCGA-66-2758-01A-02D-1522-08	LUSC	71c4e854-a704-4787-a37a-fa6642ca5dac
TCGA-66-2759-01A-01D-1522-08	LUSC	fecd0a2b-d176-438a-be95-306f453fde40
TCGA-66-2763-01A-01D-1522-08	LUSC	d6493c56-5322-4961-a693-8e8a62b0f7f1
TCGA-66-2765-01A-01D-1522-08	LUSC	85d7e094-ca96-4090-83aa-2f318ae6e954
TCGA-66-2766-01A-01D-1522-08	LUSC	452b75d0-1818-46aa-8804-9cfc0bd66449
TCGA-66-2767-01A-01D-1522-08	LUSC	ca748128-272c-4fad-9a1f-01328b93b3f4
TCGA-66-2768-01A-01D-1522-08	LUSC	5d458cef-965d-4d27-b754-31df67ed6eaa
TCGA-66-2770-01A-01D-1522-08	LUSC	e417903d-ab76-44f0-aae9-3a91fa9a8d3c
TCGA-66-2771-01A-01D-0983-08	LUSC	58c73372-223f-400a-a2df-073a78c58b62
TCGA-66-2773-01A-01D-1267-08	LUSC	fb0b515b-afc4-40c3-abe6-e90c442f0249
TCGA-66-2777-01A-01D-1267-08	LUSC	2ea52fb8-d7c9-48ce-9aef-50df7c42e5d5
TCGA-66-2778-01A-02D-1522-08	LUSC	5215060d-5ffd-49f3-a7a7-73167e7af74a
TCGA-66-2780-01A-01D-1522-08	LUSC	d088bd17-a1a0-4bd9-bfe1-d57b5725c53b
TCGA-66-2781-01A-01D-1522-08	LUSC	bfb33630-c8a8-4ec4-9eee-8bef349339ea
TCGA-66-2782-01A-01D-1522-08	LUSC	640ff507-203c-45aa-8bc1-030ee8639b5d
TCGA-66-2783-01A-01D-1267-08	LUSC	f574d3b7-4ae4-49bc-9e05-f965fbc86119
TCGA-66-2785-01A-01D-1522-08	LUSC	57debe39-f57d-400a-a860-3de357d6bec1
TCGA-66-2786-01A-01D-1522-08	LUSC	999a6582-33cf-47ca-b268-9b2da102e99b
TCGA-66-2787-01A-01D-0983-08	LUSC	c59e5971-e243-4b00-b5f0-f4bca18530d6
TCGA-66-2788-01A-01D-0983-08	LUSC	2466d424-98bb-4380-9967-36abaa0e69d7
TCGA-66-2789-01A-01D-0983-08	LUSC	fab8faeb-35b3-42f0-b0af-4dfb1325a21a
TCGA-66-2791-01A-01D-0983-08	LUSC	dd468431-2fa4-45ab-bel-f-90671891c5c4
TCGA-66-2792-01A-01D-0983-08	LUSC	b704a17a-9ee9-4555-b2bb-250ac1ec5bed
TCGA-66-2793-01A-01D-1267-08	LUSC	7dc5f8ba-0080-43d3-8426-bd527a970761
TCGA-66-2794-01A-01D-1267-08	LUSC	2c58fa70-8fef-4a49-8cde-bfdc92e77919
TCGA-66-2795-01A-02D-0983-08	LUSC	73825564-8731-4137-972a-330490aceadc
TCGA-66-2800-01A-01D-1267-08	LUSC	803ec3a5-4347-41c3-a7b6-7eb00427a48c
TCGA-70-6722-01A-11D-1817-08	LUSC	e81f1bb5-2d06-44b3-998a-e7a0b818467c
TCGA-70-6723-01A-11D-1817-08	LUSC	7483ea9f-8587-41e7-9ae5-d9223b76f33e
TCGA-85-6175-01A-11D-1817-08	LUSC	2ba53bf0-a4e1-4b46-b258-610522aac7ee
TCGA-85-6560-01A-11D-1817-08	LUSC	a5a156b8-2c8a-4ed0-8bae-b60cdc95698f
TCGA-85-6561-01A-11D-1817-08	LUSC	f5aa0f1c-da19-4c04-b695-01ed5b20e79e
TCGA-04-1332-01A-01W-0488-09	OV	b52e5d90-dc57-438c-9c38-e043308c24ac
TCGA-04-1336-01A-01W-0488-09	OV	586101df-93c9-4d0b-ba0e-58df7a2f9598
TCGA-04-1343-01A-01W-0488-09	OV	fbbc3d80-aff2-463e-8eb3-c4361ad7cb98
TCGA-04-1346-01A-01W-0488-09	OV	9f494df7-f64f-4935-ae42-eeb0b94624dc
TCGA-04-1347-01A-01W-0488-09	OV	21b50b8c-781a-4e15-a4ad-715f416f0fa2
TCGA-04-1348-01A-01W-0494-09	OV	1f4dee42-8f3d-4307-b6e5-3381d77d201c
TCGA-04-1349-01A-01W-0494-09	OV	e456f707-f0a0-4624-98bc-e9dfe779182b

2019203664 24 May 2019

TCGA-04-1361-01A-01W-0494-09	OV	0fc567bd-2201-4f3d-820e-2c0dbe58da6f
TCGA-04-1362-01A-01W-0494-09	OV	830e207f-458e-4628-b7bc-287c2f2e12e5
TCGA-04-1542-01A-01W-0553-09	OV	317a63af-e862-43df-8ef5-7c555b2cb678
TCGA-09-0366-01A-01W-0372-09	OV	62269d21-50dc-42b0-b1e4-75ed8010080a
TCGA-09-0369-01A-01W-0372-09	OV	633f5c4d-c224-404c-9f68-24daafd1fc84
TCGA-10-0930-01A-02W-0421-09	OV	ec98ed86-1d2f-4e54-b2d4-5976469bf0b8
TCGA-10-0933-01A-01W-0421-09	OV	3ec4215f-b57d-4ae7-b247-55ea1f7e97d3
TCGA-10-0935-01A-03W-0421-09	OV	af0edbf4-9d90-4373-a9ce-0875ebbe1d04
TCGA-13-0723-01A-02W-0372-09	OV	6f9e5a76-5d2a-4bb0-babf-3f365a177236
TCGA-13-0724-01A-01W-0372-09	OV	2b6aa1c8-5150-4d8f-af59-d5a826321308
TCGA-13-0726-01A-01W-0372-09	OV	201415c2-5b5a-4bb8-8005-bf2c78d4d88e
TCGA-13-0755-01A-01W-0372-09	OV	9bd227fa-e52a-4805-bd04-ad63df0930af
TCGA-13-0760-01A-01W-0372-09	OV	5181630f-246a-4cb4-88c2-1534b5fb8e37
TCGA-13-0765-01A-01W-0372-09	OV	5bcfe3ea-d95e-47ff-9718-6b123d3acaef
TCGA-13-0791-01A-01W-0372-09	OV	70f63e2f-9bc6-4ed9-8d91-f1889287d7b7
TCGA-13-0795-01A-01W-0372-09	OV	b266a007-694a-4580-ad67-48b0f709bc43
TCGA-13-0800-01A-01W-0372-09	OV	757862e3-0392-4e05-a242-25e3d2094ee8
TCGA-13-0804-01A-01W-0372-09	OV	7f39610d-45b8-45ae-806e-16b7acebafa6
TCGA-13-0807-01B-02W-0421-09	OV	f80466d9-6cc8-461b-acc2-addee22bd42a
TCGA-13-0884-01B-01W-0494-09	OV	c5f0aa38-556b-401c-b4da-ac82cdc2e637
TCGA-13-0885-01A-02W-0421-09	OV	a530d9a9-b21e-47be-b4d8-1707b71f360a
TCGA-13-0887-01A-01W-0421-09	OV	e05146f2-688d-416b-a992-e2c7a2b7b244
TCGA-13-0890-01A-01W-0421-09	OV	15b867fb-7a7b-4158-9abd-91870ba77eb7
TCGA-13-0893-01B-01W-0494-09	OV	a335ab49-84b7-4d3b-a03d-9c3931904ca5
TCGA-13-0894-01B-01W-0494-09	OV	eb57990e-702f-4fac-9ef5-7447ecb45ccc
TCGA-13-0897-01A-01W-0421-09	OV	f48ed68f-a833-4b78-971a-3c746c563d24
TCGA-13-0903-01A-01W-0421-09	OV	854167b5-03ab-4867-af34-9c92e385822e
TCGA-13-0910-01A-01W-0421-09	OV	26cebe0b-b7a7-431e-bc12-7fda22af72f3
TCGA-13-0912-01A-01W-0421-09	OV	517f4d7f-c962-414f-8824-f2a7ae19cb6d
TCGA-13-0920-01A-01W-0421-09	OV	2e28969b-c9a9-41ec-80bf-f583197b7f92
TCGA-13-0924-01A-01W-0421-09	OV	510dda3c-6a1f-4781-972f-c9c270608c72
TCGA-13-1403-01A-01W-0494-09	OV	acbc77ba-7cc0-4af2-9ab6-0c835ce33998
TCGA-13-1404-01A-01W-0494-09	OV	692e4b24-daf0-4771-b4a6-b0599f122ad8
TCGA-13-1405-01A-01W-0494-09	OV	c0d1de72-4cce-4d74-93f0-29c462dc1426
TCGA-13-1411-01A-01W-0494-09	OV	e254d7f4-1edf-4054-9ca6-9fe058a05484
TCGA-13-1412-01A-01W-0494-09	OV	f7edafe2-3eab-4bac-9d25-ed5c223b4aee
TCGA-13-1481-01A-01W-0549-09	OV	f9eab025-5518-4240-b1a8-19f8ff8354f0
TCGA-13-1482-01A-01W-0549-09	OV	a68927d4-e827-49c9-9c3a-23ce0543261b
TCGA-13-1483-01A-01W-0549-09	OV	52280c07-44f5-4e9c-8601-7455b5b0de7a
TCGA-13-1488-01A-01W-0549-09	OV	886a8c10-63cf-4cb2-83d2-5a99bbda193d
TCGA-13-1489-01A-01W-0549-09	OV	395c1d93-7216-4c9d-bfad-26ff95fb8afe



2019203664 24 May 2019

TCGA-13-1491-01A-01W-0549-09	OV	fb7d1c2b-3e87-4d05-a58b-92d0e1016986
TCGA-13-1497-01A-01W-0549-09	OV	04e814c6-ea28-4ade-bc8f-a618552943da
TCGA-13-1498-01A-01W-0549-09	OV	b00d9680-4099-43fe-87de-b3cc8b9e70c8
TCGA-13-1499-01A-01W-0549-09	OV	b4ce07b1-677e-4a9c-8f8e-2b7762487692
TCGA-13-1506-01A-01W-0549-09	OV	7534b542-88f8-445c-ae4a-9f44fb6798a8
TCGA-13-1507-01A-01W-0549-09	OV	5423db1a-5b59-4a5b-a676-00a54570b04a
TCGA-13-1509-01A-01W-0549-09	OV	4d3fab96-bc22-48d0-a3ef-1844ad894d0f
TCGA-23-1021-01B-01W-0488-09	OV	4f14d366-4750-471f-98a1-a01934365ee1
TCGA-23-1022-01A-02W-0488-09	OV	160a0e7d-315e-4de3-a7d4-928412fd909c
TCGA-23-1117-01A-02W-0488-09	OV	3a4b0c6a-1f43-437c-b715-fc50c1c0303d
TCGA-23-1118-01A-01W-0488-09	OV	00c41845-6b48-40fa-82e9-1b436e7d91c3
TCGA-23-1123-01A-01W-0488-09	OV	22cfe2c8-5e1f-4b64-854d-2a7a02bf10fe
TCGA-23-1124-01A-01W-0488-09	OV	8a4061a0-77f2-4bb4-a3da-9b3d9f0314b9
TCGA-24-0966-01A-01W-0977-09	OV	dc069342-661a-4012-9bda-0c67469e117d
TCGA-24-0980-01A-01W-0421-09	OV	87d32a92-a8d2-4656-a100-798328338486
TCGA-24-0982-01A-01W-0488-09	OV	7667c0e6-e44a-448f-b118-6e2171a99b6c
TCGA-24-1103-01A-01W-0488-09	OV	47b7427c-a91a-4872-bc08-50c07ba60512
TCGA-24-1104-01A-01W-0488-09	OV	9cdb7821-fe43-46cd-94f3-b9d68b9ce21f
TCGA-24-1413-01A-01W-0494-09	OV	1b2d2cde-4553-472e-82f1-8224745ac1eb
TCGA-24-1416-01A-01W-0549-09	OV	21f5e805-c0b4-487b-9ccd-02963e2369ff
TCGA-24-1417-01A-01W-0549-09	OV	f6f43d04-a9e3-48c8-a276-3bebcdf416d7
TCGA-24-1418-01A-01W-0549-09	OV	6093bc5-4889-4cb9-9b01-e4e4278e72aa
TCGA-24-1424-01A-01W-0549-09	OV	2849f3e8-85d8-4d42-953b-3190b0ca98fc
TCGA-24-1425-01A-02W-0553-09	OV	f8d4c37d-5b4d-4f5a-8022-7da2b32cc1b0
TCGA-24-1426-01A-01W-0549-09	OV	063f8696-2c9d-4af4-a863-df10c42a5ea8
TCGA-24-1427-01A-01W-0549-09	OV	6511d3d4-722c-4702-a644-29bb98e5e5c3
TCGA-24-1428-01A-01W-0549-09	OV	52866517-eddf-4d63-a121-a296d6b2d264
TCGA-24-1435-01A-01W-0549-09	OV	28d236f6-dddc-48c2-be30-b1568a4d6055
TCGA-24-1436-01A-01W-0549-09	OV	adef0f5-d2a3-41c5-a509-298f702266bb
TCGA-24-1463-01A-01W-0549-09	OV	c01ca9e7-ee9b-4698-8e4d-920ad7bfbe5f
TCGA-24-1464-01A-01W-0549-09	OV	01ec3cbb-c68a-4874-b396-f5e34876e04a
TCGA-24-1469-01A-01W-0553-09	OV	990c4b9d-608d-4b85-959c-5cc12f4e10fc
TCGA-24-1470-01A-01W-0553-09	OV	1d2bf111-910b-4ce9-8638-ab992b414e65
TCGA-24-1549-01A-01W-0553-09	OV	b2e252bd-895f-4b28-9367-dd527331010f
TCGA-24-1562-01A-01W-0553-09	OV	5e49bcea-9c1d-4cfd-a64c-4b84859bdda5
TCGA-24-1563-01A-01W-0553-09	OV	b6c46b53-f94d-4936-9005-518c8f1c1449
TCGA-24-1616-01A-01W-0553-09	OV	c464b2f6-9cfe-463a-b5e3-9a76cd4480c5
TCGA-25-1315-01A-01W-0494-09	OV	52f45b5e-af86-454c-be63-a56c6c21b730
TCGA-25-1316-01A-01W-0494-09	OV	d75a0b16-04e4-4ba3-a695-132c5ace698b
TCGA-25-1322-01A-01W-0494-09	OV	626f1798-fb15-4b01-8d8f-db19777d72e9

2019203664 24 May 2019

TCGA-AF-3913-01A-02W-1073-09	READ	4ebe7cf9-ce4f-485d-9332-ea9b536e38e2
TCGA-AG-3887-01A-01W-1073-09	READ	6d2de0f5-e812-4d3f-903b-7febdcfd2f7
TCGA-AG-3890-01A-01W-1073-09	READ	042e984f-c106-4b23-9908-5abaf407e694
TCGA-AG-3892-01A-01W-1073-09	READ	26acdae6-b01a-4dbd-b0b8-f6d97fe01808
TCGA-AG-3893-01A-01W-1073-09	READ	0faa6d28-c01c-4847-9552-912733485610
TCGA-AG-3894-01A-01W-1073-09	READ	e508d0c8-cdaf-463f-bb03-47af1bc41866
TCGA-AG-3896-01A-01W-1073-09	READ	22c7d09a-e69b-44be-8d8e-0a0cc9adf57c
TCGA-AG-3898-01A-01W-1073-09	READ	cc3516ba-2941-4efa-80fc-7b5041194d52
TCGA-AG-3901-01A-01W-1073-09	READ	84859471-1136-4f42-ab75-b27a4ef27199
TCGA-AG-3902-01A-01W-1073-09	READ	b679f02d-f48d-49eb-b245-65f341e4c181
TCGA-AG-3909-01A-01W-1073-09	READ	f5ece3cf-39eb-4277-8975-986e548bc1ea
TCGA-AG-3999-01A-01W-1073-09	READ	0445426d-b9c0-4ce5-b1cc-cb236d4381cf
TCGA-AG-4001-01A-02W-1073-09	READ	55075176-07a4-4183-9f8f-9f472b15a6b4
TCGA-AG-4005-01A-01W-1073-09	READ	be1d3bda-de1a-4768-a2e4-22c07326ddc3
TCGA-AG-4007-01A-01W-1073-09	READ	6fcfdc8f-22c0-4c3a-9e46-58c0a68e818e
TCGA-AG-4008-01A-01W-1073-09	READ	83cd3c15-8eab-4d46-b9a2-36ee719f6774
TCGA-AG-4015-01A-01W-1073-09	READ	cf6f8e0f-04bf-4a0d-933e-8034ba6c1607
TCGA-AG-A008-01A-01W-A005-10	READ	2221cfc4-b324-4329-ad37-3dd9a5adf36e
TCGA-AG-A00C-01A-01W-A005-10	READ	1a4f95be-32d3-4202-a0e7-507181b3fb86
TCGA-AG-A00H-01A-01W-A00E-09	READ	fdc4c8ac-fee2-4801-ae94-94c5d8058a9f
TCGA-AG-A00Y-01A-02W-A005-10	READ	b50ae1df-ee6f-4a5e-ba4b-c962d740ab22
TCGA-AG-A011-01A	READ	b5dd8f49-26fc-48d9-a964-d8ebdcca9e19
TCGA-AG-A014-01A	READ	fbfa61fe-4fb7-4b2a-9bf0-33140fd41873
TCGA-AG-A015-01A-01W-A005-10	READ	abb751f0-c4df-4556-ac9b-ad1e1971cccf
TCGA-AG-A016-01A-01W-A005-10	READ	f20ae301-b10b-4dfa-9169-04bc6c3d103a
TCGA-AG-A01L-01A	READ	b034c90b-d0bd-466a-88ba-b61efd36c6e4
TCGA-AG-A025-01A-01W-A00E-09	READ	7b5a3c33-cd13-4e4d-a1f8-3405dab5998f
TCGA-AG-A02G-01A-01W-A00E-09	READ	954527dc-8a7d-474d-b580-82199e86cb5a
TCGA-AG-A02X-01A-01W-A00E-09	READ	9ffb8919-a98c-40bd-bdad-146b1ccc14ef
TCGA-AG-A032-01A-01W-A00E-09	READ	7522eb6b-797a-4964-8aca-6d70590b5f9f

**Pipeline for prediction of peptides derived from gene mutations with binding to personal HLA alleles:** MHC-binding affinity was predicted across all possible 9-mer and 10-mer peptides generated from each somatic mutation and the corresponding wildtype peptide using NetMHCpan (version 2.4). These tiled peptides were analyzed for their binding affinities (IC<sub>50</sub> nM) to each class I alleles in the patients' HLA profile. An IC<sub>50</sub> value of less than 150 nM was considered a predicted strong to intermediate binder, an IC<sub>50</sub> of 150-500 nM was

2019203664 24 May 2019

considered a predicted weak binder, while an  $IC_{50} > 500$  nM was considered a non-binder. Experimental confirmation of predicted peptides binding to HLA molecules ( $IC_{50} < 500$  nM) was performed using a competitive MHC class I allele-binding assay and has been described in detail elsewhere (Cai et al. 28 and Sidney et al. 2001).

**Sources of antigen:** Peptides were synthesized to  $>95\%$  purity (confirmed by high performance liquid chromatography) from New England Peptide (Gardner, MA); or RS Synthesis, (Louisville, KY). Peptides were reconstituted in DMSO (10 mg/ml) and stored at  $-80^{\circ}C$  until use. Minigenes comprised of a sequence of 300 bp encompassing mut or wt *FNDC3B* were PCR-cloned from Pt 2's tumor into the expression vector pcDNA3.1 using the following primers: 5' primer: GACGTCGGATCCCACCATGGGTCCCGGAATTAAGAAAACAGAG; 3' primer: CCCGGGGCGGCCGCCTAATGGTGATGGTGATGGTGACATTCTAATTCTTCTCCACTGTAAA. Minigenes were expressed in antigen-presenting target cells by introducing 20  $\mu$ g of the plasmid into 2 million K562 cells (ATCC) stably transfected with HLA-A2 by Amaxa nucleofection (Solution V, Program T16, Lonza Inc; Walkersville, MD). Cells were incubated in RPMI media (Cellgro; Manassas, VA), supplemented with 10% fetal bovine serum (Cellgro), 1% HEPES buffer (Cellgro), and 1% L-glutamine (Cellgro). The cells were harvested 2 days following nucleofection for immune assays.

**Analysis of gene expression in CLL cases:** previously reported microarray data (NCI Gene Expression Omnibus accession GSE37168) was reanalyzed. Affymetrix CEL files were processed using the affy package in R. The Robust Multichip Analysis (RMA) algorithm was used for background correction which models the observed intensities as a mixture of

201920203664 24 May 2019

exponentially distributed signal and normally distributed noise. This was followed by quantile normalization across arrays to facilitate comparison of gene expression under different conditions. The individual probe-level was finally summarized using the median polish approach to get robust probeset-level values. Gene-level values were obtained by selecting the probe with the maximal average expression for each gene. Batch effects in the data were removed by using the Combat program.

#### **Generation and detection of antigen specific T cells from patient PBMCs:**

Autologous dendritic cells (DCs) were generated from immunomagnetically-isolated CD14<sup>+</sup> cells (Miltenyi, Auburn CA) that were cultured in RPMI (Cellgro) supplemented with 3% fetal bovine serum, 1% penicillin-streptomycin (Cellgro), 1% L-glutamine and 1% HEPES buffer in the presence of 120 ng/ml GM-CSF and 70 ng/ml IL-4 (R&D Systems, Minneapolis, MN). On days three and five, additional GM-CSF and IL-4 were added. On day six, cells were exposed to 30µg/ml Poly I:C (Sigma Aldrich, St Louis, MO) to undergo maturation (for 48 hours), in addition to adding IL-4 and GM-CSF. CD19<sup>+</sup> B cells were isolated from patient PBMCs by immunomagnetic selection (CD19<sup>+</sup> microbeads; Miltenyi, Auburn, CA), and seeded at 1x10<sup>6</sup> cells/well in a 24-well plate. B cells were cultured in *B cell media* (Iscoves modified Dulbecco medium (IMDM; Life Technologies, Woburn, MA), supplemented with 10% human AB serum (GemCell, Sacramento, CA), 5µg/mL insulin (Sigma Chemical, St Louis, MO), 15 µg/mL gentamicin, IL-4 (2ng/ml, R&D Systems, Minneapolis, MN) and CD40L-Tri (1µg/ml). CD40L-Tri was replenished every 3-4 days. For some experiments, CD40L-Tri activated and expanded CD19<sup>+</sup> B cells were used as APCs.

20

2019203664 24 May 2019

**Generation of antigen-specific T cells from patient PBMCs:** To generate peptide-reactive T cells from CLL patients, immunomagnetically selected CD8<sup>+</sup> T cells ( $5 \times 10^6$ /well) from pre- and post-transplant PBMCs (CD8+ Microbeads, Miltenyi, Auburn, CA) were cultured with autologous peptide pool-pulsed DCs (at 40:1 ratio) or CD40L-Tri-activated irradiated B cells (at 4:1 ratio) respectively, in complete medium supplemented with 10% FBS and 5-10 ng/mL IL-7, IL-12 and IL-15. APCs were pulsed for 3 hours with peptide pools (10  $\mu$ M/peptide/pool). CD8<sup>+</sup> T cells were re-stimulated weekly (for 1-3 weeks, starting on day 7) with APCs.

**Detection of antigen-specific T cells:** T cell specificity against peptide pools was tested by IFN- $\gamma$  ELISPOT assay, 10 days following 2<sup>nd</sup> and 4<sup>th</sup> stimulations. IFN- $\gamma$  release was detected using test and control peptide-pulsed CD40L-activated B cells (50,000 cells/well) co-incubated with 50,000 CD8<sup>+</sup> T cells/well (Millipore, Billerica, MA) for 24 hours on ELISPOT plate. IFN- $\gamma$  was detected using capture and detection antibodies, as directed (Mabtech AB, Mariemont, OH), and imaged (ImmunoSpot Series Analyzer; Cellular Technology, Cleveland, OH). To test T cell reactivity dependence on MHC class I, ELISPOT plates were first coated with APCs co-incubated with class I blocking antibody (W6/32) for 2 hours at 37°C, prior to introduction of T cells into the wells. MHC class I tetramer was used to test specificity of T cells where indicated (Emory University, Atlanta GA). For tetramer staining,  $5 \times 10^5$  cells were incubated for 60 minutes at 4°C with 1  $\mu$ g/mL PE-labeled tetramer, and then incubated with the addition of anti-  
20 CD3-FITC and anti-CD8-APC antibodies (BD Biosciences, San Diego CA) for another 30 minutes at 4°C. A minimum of 100,000 events were acquired per sample. Secretion of GM-CSF and IL-2 from cultured CD8<sup>+</sup> T cells was detected by analysis of culture supernatants using a Luminex multiplex bead-based technology, per the manufacturer's recommendations (EMD

2019203664 24 May 2019

Millipore, Billerica, MA). In brief, fluorescent-labeled microspheres were coated with specific cytokine capture antibodies. After incubation with the culture supernatant sample, captured cytokines were detected by a biotinylated detection antibody followed by a streptavidin-PE conjugate and median fluorescence intensity (MFI) was measured (Luminex 200 Bead Array instrument; Luminex Corporation, Austin TX). Based on a standard curve, cytokine levels were calculated in the Bead View Software program (Upstate, EMD Millipore, Billerica, MA). For detection and quantitation of TCR V $\beta$  clonotypes, *mut-FNDC3B* specific T cells were enriched from Pt 2's T cell lines using the IFN- $\gamma$  secretion assay (Miltenyi, Auburn, CA) according to the manufacturer's instructions and as previously described.

**Statistical considerations:** Two-way ANOVA models were constructed for T cells reactivity against mut vs wt peptide in the form of IFN-gamma, GM-CSF, and IL-2 release and included concentration and mutational status as fixed effects along with an interaction term as appropriate. *P*-values for these models were adjusted for multiple comparisons post-hoc using the Tukey method. For normalized comparisons of IFN-gamma, a *t*-test was performed to test the hypothesis that the normalized ratio equaled one. For other comparisons of continuous measures between groups, a Welch *t*-test was used. All *P*-values reported are two-sided and considered significant at the 0.05 level with appropriate adjustment for multiple comparisons. Analysis was performed in SAS v9.2.

**Detection and quantitation of TCR V $\beta$  clonotypes:** To detect *mut-FNDC3B* specific TCR V $\beta$ , a two-step nested PCR from peptide-specific IFN- $\gamma$  enriched T cell populations was performed. In short, the dominant V $\beta$  subfamily was identified among the 24 known V $\beta$  subfamilies. First, 5 pools of V $\beta$  forward primers (pool 1: V $\beta$  1–5.1; pool 2: V $\beta$  5.2–9; pool 3:

2019203664 24 May 2019

V $\beta$  10–13.2; pool 4: V $\beta$  14–19; and pool 5: V $\beta$  20, 22–25) were generated. RNA extracted from the T cell clones (QIAamp RNA Blood Mini-kit; Qiagen, Valencia, CA), was reverse transcribed into cDNA (Superscript, GIBCO BRL, Gaithersburg, MD) using random hexamers, and PCR-amplified in five separate 20  $\mu$ l volume reactions. Second, T cell clone-derived cDNA was re-amplified, with each of the 5 individual primers contained within a positive pool together with a FAM-conjugated C $\beta$  reverse (internal) primer. Subsequently, 4  $\mu$ l of this PCR product was amplified with 1  $\mu$ l of the clone CDR3 region-specific primer and probe, and 10  $\mu$ l of Taqman Fast Universal PCR Master Mix (Applied Biosystems, Foster City, CA) in a total volume of 20  $\mu$ l. The PCR amplification conditions were: 95°C for 20 minutes  $\times$  1 cycle, and 40 cycles of 95°C for 3 seconds followed by 60°C for 30 seconds (7500 Fast Real-time PCR cyclers; Applied Biosystems, Foster City, CA). Test transcripts were quantified relative to *S18* ribosomal RNA transcripts by calculating  $2^{-(S18 \text{ rRNA CT} - \text{target CT})}$  as described previously.

**Detection of molecular tumor burden:** The clonotypic IgH sequence of Pt 2 was identified using a panel of VH-specific PCR primers, as previously described. Based on this sequence, a quantitative Taqman PCR assay was designed such that a sequence-specific probe was located in the region of junctional diversity (Applied Biosystems; Foster City, CA). This Taqman assay was applied to cDNA from tumor. All PCR reactions consisted of: 50°C for 1 minute  $\times$  1 cycle, 95°C for 10 minutes  $\times$  1 cycle, and 40 cycles of 95°C for 15 seconds followed by 60°C for 1 minute. All reactions were performed using a 7500 Fast Real-time PCR cycler (Applied Biosystems, Foster City, CA). Test transcripts were quantified relative to GAPDH.

20

2019203664 24 May 2019

2019203664

**REFERENCES**

- Zhang GL, Ansari HR, Bradley P, et al. Machine learning competition in immunology - Prediction of HLA class I binding peptides. *J Immunol Methods*. Nov 30 2011;374(1-2):1-4.
- Kawai T, Akira S. TLR signaling. *Seminars in immunology*. Feb 2007;19(1):24-32.
- Adams S. Toll-like receptor agonists in cancer therapy. *Immunotherapy*. Nov 2009;1(6):949-964.
- Cheever MA. Twelve immunotherapy drugs that could cure cancers. *Immunological reviews*. Apr 2008;222:357-368.
- Bogunovic D, Manches O, Godefroy E, et al. TLR4 engagement during TLR3-induced proinflammatory signaling in dendritic cells promotes IL-10-mediated suppression of antitumor immunity. *Cancer Res*. Aug 15 2011;71(16):5467-5476.
- Stahl-Hennig C, Eisenblatter M, Jasny E, et al. Synthetic double-stranded RNAs are adjuvants for the induction of T helper 1 and humoral immune responses to human papillomavirus in rhesus macaques. *PLoS pathogens*. Apr 2009;5(4):e1000373.
- Boscardin SB, Hafalla JC, Masilamani RF, et al. Antigen targeting to dendritic cells elicits long-lived T cell help for antibody responses. *The Journal of experimental medicine*. Mar 20 2006;203(3):599-606.
- Soares H, Waechter H, Glaichenhaus N, et al. A subset of dendritic cells induces CD4+ T cells to produce IFN-gamma by an IL-12-independent but CD70-dependent mechanism in vivo. *The Journal of experimental medicine*. May 14 2007;204(5):1095-1106.
- Trumfheller C, Caskey M, Nchinda G, et al. The microbial mimic poly IC induces durable and protective CD4+ T cell immunity together with a dendritic cell targeted vaccine. *Proc Natl Acad Sci U S A*. Feb 19 2008;105(7):2574-2579.
- Trumfheller C, Finke JS, Lopez CB, et al. Intensified and protective CD4+ T cell immunity in mice with anti-dendritic cell HIV gag fusion antibody vaccine. *The Journal of experimental medicine*. Mar 20 2006;203(3):607-617.
- Salem ML, Kadima AN, Cole DJ, Gillanders WE. Defining the antigen-specific T-cell response to vaccination and poly(I:C)/TLR3 signaling: evidence of enhanced primary and memory CD8 T-cell responses and antitumor immunity. *J Immunother*. May-Jun 2005;28(3):220-228.

25

30



24 May 2019

2019203664

- Tough DF, Borrow P, Sprent J. Induction of bystander T cell proliferation by viruses and type I interferon in vivo. *Science*. Jun 28 1996;272(5270):1947-1950.
- Zhu X, Nishimura F, Sasaki K, et al. Toll like receptor-3 ligand poly-ICLC promotes the efficacy of peripheral vaccinations with tumor antigen-derived peptide epitopes in murine CNS tumor models. *Journal of translational medicine*. 2007;5:10.
- Flynn BJ, Kastenmuller K, Wille-Reece U, et al. Immunization with HIV Gag targeted to dendritic cells followed by recombinant New York vaccinia virus induces robust T-cell immunity in nonhuman primates. *Proc Natl Acad Sci U S A*. Apr 26 2011;108(17):7131-7136.
- Gaucher D, Therrien R, Kettaf N, et al. Yellow fever vaccine induces integrated multilineage and polyfunctional immune responses. *The Journal of experimental medicine*. Dec 22 2008;205(13):3119-3131.
- Caskey M, Lefebvre F, Filali-Mouhim A, et al. Synthetic double-stranded RNA induces innate immune responses similar to a live viral vaccine in humans. *The Journal of experimental medicine*. Nov 21 2011;208(12):2357-2366.
- Sabbatini P, Tsuji T, Ferran L, et al. Phase I trial of overlapping long peptides from a tumor self-antigen and poly-ICLC shows rapid induction of integrated immune response in ovarian cancer patients. *Clinical cancer research : an official journal of the American Association for Cancer Research*. Dec 1 2012;18(23):6497-6508.
- Robinson RA, DeVita VT, Levy HB, Baron S, Hubbard SP, Levine AS. A phase I-II trial of multiple-dose polyribonucleic-acid in patients with leukemia or solid tumors. *Journal of the National Cancer Institute*. Sep 1976;57(3):599-602.
- Siegel R, Naishadham D, Jemal A. *Cancer statistics, 2013*. CA: a cancer journal for clinicians. Jan 2013;63(1):11-30.
- 25 Balch CM, Gershenwald JE, Soong SJ, et al. Final version of 2009 AJCC melanoma staging and classification. *Journal of clinical oncology : official journal of the American Society of Clinical Oncology*. Dec 20 2009;27(36):6199-6206.
- Eggermont AM, Suci S, Testori A, et al. Ulceration and stage are predictive of interferon efficacy in melanoma: results of the phase III adjuvant trials EORTC 18952 and EORTC 30 18991. *Eur J Cancer*. Jan 2012;48(2):218-225.

2019203664 24 May 2019

Sosman JA, Moon J, Tuthill RJ, et al. A phase 2 trial of complete resection for stage IV melanoma: results of Southwest Oncology Group Clinical Trial S9430. *Cancer*. Oct 15 2011;117(20):4740-4706.

Flaherty KT, Hodi FS, Fisher DE. From genes to drugs: targeted strategies for melanoma. *Nat Rev Cancer*. May 2012;12(5):349-361.

Mocellin S, Pasquali S, Rossi CR, Nitti D. Interferon alpha adjuvant therapy in patients with high-risk melanoma: a systematic review and meta-analysis. *Journal of the National Cancer Institute*. Apr 7 2010;102(7):493-501.

Pirard D, Heenen M, Melot C, Vereecken P. Interferon alpha as adjuvant postsurgical treatment of melanoma: a meta-analysis. *Dermatology*. 2004;208(1):43-48.

Wheatley K, Ives N, Hancock B, Gore M, Eggermont A, Suci S. Does adjuvant interferon-alpha for high-risk melanoma provide a worthwhile benefit? A meta-analysis of the randomised trials. *Cancer treatment reviews*. Aug 2003;29(4):241-252.

Buckwalter MR, Srivastava PK. "It is the antigen(s), stupid" and other lessons from over a decade of vaccitherapy of human cancer. *Seminars in immunology*. Oct 2008;20(5):296-300.

Baurain JF, Colau D, van Baren N, et al. High frequency of autologous anti-melanoma CTL directed against an antigen generated by a point mutation in a new helicase gene. *J Immunol*. Jun 1 2000;164(11):6057-6066.

Chiari R, Foury F, De Plaen E, Baurain JF, Thonnard J, Coulie PG. Two antigens recognized by autologous cytolytic T lymphocytes on a melanoma result from a single point mutation in an essential housekeeping gene. *Cancer Res*. Nov 15 1999;59(22):5785-5792.

Huang J, El-Gamil M, Dudley ME, Li YF, Rosenberg SA, Robbins PF. T cells associated with tumor regression recognize frameshifted products of the CDKN2A tumor suppressor gene locus and a mutated HLA class I gene product. *J Immunol*. May 15 2004;172(10):6057-6064.

Karanikas V, Colau D, Baurain JF, et al. High frequency of cytolytic T lymphocytes directed against a tumor-specific mutated antigen detectable with HLA tetramers in the blood of a lung carcinoma patient with long survival. *Cancer Res*. May 1 2001;61(9):3718-3724.

25

24 May 2019

2019203664

- Lennerz V, Fatho M, Gentilini C, et al. The response of autologous T cells to a human melanoma is dominated by mutated neoantigens. *Proc Natl Acad Sci U S A*. Nov 1 2005;102(44):16013-16018.
- Zorn E, Hercend T. A natural cytotoxic T cell response in a spontaneously regressing human melanoma targets a neoantigen resulting from a somatic point mutation. *Eur J Immunol*. Feb 1999;29(2):592-601.
- Kannan S, Neelapu SS. Vaccination strategies in follicular lymphoma. *Current hematologic malignancy reports*. Oct 2009;4(4):189-195.
- Kenter GG, Welters MJ, Valentijn AR, et al. Phase I immunotherapeutic trial with long peptides spanning the E6 and E7 sequences of high-risk human papillomavirus 16 in end-stage cervical cancer patients shows low toxicity and robust immunogenicity. *Clinical cancer research : an official journal of the American Association for Cancer Research*. Jan 1 2008;14(1):169-177.
- Kenter GG, Welters MJ, Valentijn AR, et al. Vaccination against HPV-16 oncoproteins for vulvar intraepithelial neoplasia. *The New England journal of medicine*. Nov 5 2009;361(19):1838-1847.
- Welters MJ, Kenter GG, Piersma SJ, et al. Induction of tumor-specific CD4+ and CD8+ T-cell immunity in cervical cancer patients by a human papillomavirus type 16 E6 and E7 long peptides vaccine. *Clinical cancer research : an official journal of the American Association for Cancer Research*. Jan 1 2008;14(1):178-187.
- Lundegaard C, Lund O, Nielsen M. Prediction of epitopes using neural network based methods. *J Immunol Methods*. Nov 30 2011;374(1-2):26-34.
- Schreiber RD, Old LJ, Smyth MJ. Cancer immunoediting: integrating immunity's roles in cancer suppression and promotion. *Science*. Mar 25 2011;331(6024):1565-1570.
- 25 Berger, M. et al. Melanoma genome sequencing reveals frequent PREX2 mutations. *Nature* 485, 502-6 (2012).
- Carter, SL. et al. Absolute quantification of somatic DNA alterations in human cancer. *Nat Biotechnol* 30, 413-21 (2012).
- 30 Chapman, M.A. et al. Initial genome sequencing and analysis of multiple myeloma. *Nature* 471, 467-72 (2011).

2019203664 24 May 2019

- Cibulskis, K. et al. ContEst: estimating cross-contamination of human samples in next-generation sequencing data. *Bioinformatics* 27, 2601-2 (2011).
- Cibulskis, K. et al. Sensitive detection of somatic point mutations in impure and heterogeneous cancer samples. *Nature Biotech* (2013) Feb 10. doi: 10.1038/nbt.2514. [Epub ahead of print].
- DeLuca, DS. et al. RNA-SeQC: RNA-seq metrics for quality control and process optimization. *Bioinformatics* 28, 1530-2 (2012).
- DePristo, M. et al. A framework for variation discovery and genotyping using next-generation DNA sequencing data. *Nature Genetics* 43, 491-498 (2011).
- Landau, DA. et al. Evolution and impact of subclonal mutations in chronic lymphocytic leukemia. *Cell* 152, 714-26 (2013).
- Langmead, B. et al. Ultrafast and memory-efficient alignment of short DNA sequences to the human genome. *Genome Biology* 10, R25 (2009).
- Li, B. et al. RSEM: accurate transcript quantification from RNA-Seq data with or without a reference genome. *BMC Bioinformatics* 12, 323 (2011).
- Li, H. et al. The Sequence Alignment/Map format and SAMtools. *Bioinformatics* 25, 2078-9 (2009).
- Li H. and Durbin R. Fast and accurate short read alignment with Burrows-Wheeler Transform. *Bioinformatics* 25, 1754-60 (2009).
- McKenna, A. et al. The Genome Analysis Toolkit: a MapReduce framework for analyzing next-generation DNA sequencing data. *Genome Res* 20, 1297-303 (2010).
- Robinson, JT. et al. Integrative genomics viewer. *Nature Biotech* 29, 24-26 (2011).
- Stransky, N. et al. The mutational landscape of head and neck squamous cell carcinoma. *Science* 333, 1157-60 (2011).
- 25 Garraway, L.A. and Lander, E. S, Lessons from the cancer genome. *Cell*. **153**, 17-37 (2013).
- Lundegaard, C. et al. Prediction of epitopes using neural network based methods. *J Immunol Methods*. 374, 26-34 (2011).
- Sette, A. et al., The relationship between class I binding affinity and immunogenicity of potential cytotoxic T cell epitopes. *J Immunol*. 153, 5586-5592 (1994).

2019203664 24 May 2019

Lu, Y. C. et al., Mutated regions of nucleophosmin 1PPP1R3B Is Recognized by T Cells Used To Treat a Melanoma Patient Who Experienced a Durable Complete Tumor Regression. *J Immunol.* 190, 6034-6042 (2013).

Sykulev, Y. et al., Evidence that a single peptide-MHC complex on a target cell can elicit a cytolytic T cell response. *Immunity.* 4, 565-571 (1996).

Carter, S. L. et al., Absolute quantification of somatic DNA alterations in human cancer. *Nat. Biotechnology* 30: 413-21 (2012).

Sidney, J. et al., HLA class I supertypes: a revised and updated classification. *BMC Immunol.* 9, 1 (2008).

Comprehensive genomic characterization of squamous cell lung cancers. *Nature.* 489, 519-525 (2012).

Ding, L. et al., Somatic mutations affect key pathways in lung adenocarcinoma. *Nature.* 455, 1069-1075 (2008).

Stransky, N. et al., The mutational landscape of head and neck squamous cell carcinoma. *Science* 333, 1157-1160 (2011).

Comprehensive molecular characterization of human colon and rectal cancer. *Nature.* 487, 330-337 (2012).

Comprehensive genomic characterization defines human glioblastoma genes and core pathways. *Nature.* 455, 1061-1068 (2008).

Integrated genomic analyses of ovarian carcinoma. *Nature.* 474, 609-615 (Jun 30, 2011).

Comprehensive molecular characterization of clear cell renal cell carcinoma. *Nature.* 499, 43-49 (2013).

Genomic and epigenomic landscapes of adult de novo acute myeloid leukemia. *N Engl J Med.* 368, 2059-2074 (2013).

25 Comprehensive molecular portraits of human breast tumours. *Nature.* 490, 61-70 (2012).

### Other Embodiments

From the foregoing description, it will be apparent that variations and modifications may be made to the invention described herein to adopt it to various usages and conditions. Such  
30 embodiments are also within the scope of the following claims.

2019203664 24 May 2019

The recitation of a listing of elements in any definition of a variable herein includes definitions of that variable as any single element or combination (or sub-combination) of listed elements. The recitation of an embodiment herein includes that embodiment as any single embodiment or in combination with any other embodiments or portions thereof.

**Incorporation by Reference**

All patents and publications mentioned in this specification are herein incorporated by reference to the same extent as if each independent patent and publication was specifically and individually indicated to be incorporated by reference.

The claims defining the invention are as follows:

1. A method of inducing an immune response in a subject having a neoplasia, the method comprising administering to the subject an immunogenic composition that is specific to both the subject and the neoplasia, wherein the immunogenic composition comprises: (a) an optimized subset of at least five neo-antigenic peptides identified from the subject, wherein the at least five neo-antigenic peptides collectively have a higher ranking order than other neo-antigenic peptides identified from the subject collectively do; or (b) one or more polynucleotides encoding the at least five neo-antigenic peptides, wherein the ranking order in decreasing priority comprises:
  - (i) a neoORF polypeptide that binds to the HLA of the subject with a  $K_d$  of  $\leq 500$  nM encoded by a sequence comprising a neoORF mutation;
  - (ii) a polypeptide that binds to the HLA of the subject with a  $K_d$  of  $\leq 150$  nM encoded by a sequence comprising a missense mutation, wherein the native cognate protein has a  $K_d$  of  $\geq 1000$  nM;
  - (iii) a polypeptide that binds to the HLA of the subject with a  $K_d$  of  $\leq 150$  nM encoded by a sequence comprising a missense mutation, wherein the native cognate protein has a  $K_d$  of  $\leq 150$  nM;
  - (iv) a neoORF polypeptide that binds to the HLA of the subject with a  $K_d$  of  $> 500$  nM encoded by a sequence comprising a neoORF mutation; and
  - (v) a polypeptide that binds to the HLA of the subject with a  $K_d$  of  $150- \leq 500$  nM encoded by a sequence comprising a missense mutation, wherein the native cognate protein has a  $K_d$  of  $150- \leq 500$  nM.
2. A method of treating a neoplasia comprising administering a composition to a subject having the neoplasia, wherein the composition is specific to both the subject and the neoplasia, and wherein the composition comprises:
  - (a) an optimized subset of at least five neo-antigenic peptides identified from the subject, wherein the at least five neo-antigenic peptides collectively have a higher ranking order than other neo-antigenic peptides identified from the subject collectively do;

(b) one or more polynucleotides encoding the at least five neo-antigenic peptides;  
(c) antigen-presenting cells that have been pulsed with the at least five neo-antigenic peptides; or  
(d) T cells from the subject that are specific to a complex of a protein encoded by an HLA allele expressed by the subject and one or more neo-epitopes of the at least five neo-antigenic peptides, wherein the T cells have been stimulated *ex vivo* with the at least five neo-antigenic peptides, and wherein the ranking order in decreasing priority for the neo-antigenic peptides comprises:

- (i) a neoORF polypeptide that binds to the HLA of the subject with a Kd of  $\leq 500$  nM encoded by a sequence comprising a neoORF mutation;
- (ii) a polypeptide that binds to the HLA of the subject with a Kd of  $\leq 150$  nM encoded by a sequence comprising a missense mutation, wherein the native cognate protein has a Kd of  $\geq 1000$  nM;
- (iii) a polypeptide that binds to the HLA of the subject with a Kd of  $\leq 150$  nM encoded by a sequence comprising a missense mutation, wherein the native cognate protein has a Kd of  $\leq 150$  nM;
- (iv) a neoORF polypeptide that binds to the HLA of the subject with a Kd of  $> 500$  nM encoded by a sequence comprising a neoORF mutation; and
- (v) a polypeptide that binds to the HLA of the subject with a Kd of 150-  $\leq 500$  nM encoded by a sequence comprising a missense mutation, wherein the native cognate protein has a Kd of 150-  $\leq 500$  nM.

3. The method of claim 2, wherein the composition comprises:
  - (i) antigen-presenting cells, and wherein the antigen presenting cells are autologous dendritic cells; and/or
  - (ii) T cells that are from a sample of peripheral blood mononuclear cells from the subject.
4. The method of claim 3, wherein the T cells are produced by a method comprising incubating T cells from the subject *ex vivo* with the at least five neo-antigenic peptides



- and antigen-presenting cells expressing the protein encoded by an HLA allele expressed by the subject.
5. The method of any one of claims 1 to 4, wherein the composition comprises one or more polynucleotides encoding the at least five neo-antigenic peptides.
  6. The method of claim 5, wherein the one or more polynucleotides comprise:
    - (i) a minigene; or
    - (ii) a viral vector.
  7. The method of claim 6, wherein the minigene encodes at least one peptide epitope that induces a helper T-cell response.
  8. The method of any one of claims 1 to 7, wherein the subject has received a hematopoietic stem cell transplant.
  9. The method of any one of claims 1 to 8, wherein the neoplasia is surgically treated and the composition is administered at the time of the surgery.
  10. The method of any one of claims 1 to 9, wherein administering:
    - (i) comprises administering the composition at a site of surgical excision; and/or
    - (ii) comprises infusing; and/or
    - (iii) induces an immune response in the subject.
  11. The method of claim 10, wherein the immune response comprises:
    - (i) induction of anti-tumor cytotoxic T cell response; or
    - (ii) induction of a helper T cell response.
  12. The method of any one of claims 1 to 11, wherein administering further comprises (a) dividing the composition into two or more sub-pools and (b) injecting each of the sub-pools into a different location of the patient.
  13. The method of claim 12, wherein:
    - (i) each of the sub-pools injected into a different location comprises neo-antigenic peptides such that a number of individual peptides in the sub-pool targeting any single patient HLA is one or as few above one as possible; or

- (ii) the composition comprises at least 20 neo-antigenic peptides, wherein the at least 20 neo-antigenic peptides range from about 18 to about 30 amino acids in length, wherein administering further comprises dividing the produced vaccine into two or more sub-pools, wherein each sub-pool comprises at least five neo-antigenic peptides selected to optimize intra-pool interactions; or
  - (iii) optimizing comprises reducing a negative interaction among the neo-antigenic peptides in the same pool.
- 14. The method of claim 12, wherein administering further comprises delivering a dendritic cell (DC) vaccine, wherein the DC is loaded with one or more polynucleotides encoding the at least five neo-antigenic peptides.
- 15. The method of any one of claims 1 to 14, further comprising administering one or more additional neoplasia therapeutic agents, an anti-immunosuppressive agent, or an immunostimulatory agent.
- 16. The method of claim 15, wherein:
  - (i) the one or more additional neoplasia therapeutic agents comprise a chemotherapeutic agent, radiation, or immunotherapy; or
  - (ii) the anti-immunosuppressive agent or immunostimulatory agent provides a CTLA4, a PD-1, or a PD-L1 blockade; or
  - (iii) the anti-immunosuppressive agent or immunostimulatory agent comprises an anti-CTLA4 antibody, an anti-PD 1 antibody, or an anti-PD-L1 antibody.
- 17. A method comprising:
  - (a) obtaining a first set of nucleic acid sequences from a neoplasia of a subject and a second set of nucleic acid sequences from non-neoplasia cells of the subject;
  - (b) identifying a plurality of sequences comprising mutations in the neoplasia, wherein the plurality of sequences are present in the first set but not in the second set, wherein the plurality of sequences encode candidate peptide sequences comprising different mutations, and wherein the plurality of sequences are expressed by the neoplasia of the subject;

(c) analyzing the plurality of sequences comprising mutations to identify at least five neo-antigenic sequences comprising neo-antigenic mutations predicted to encode the optimized subset of at least five neo-antigenic peptides, the neo-antigenic mutations being selected from the group consisting of missense mutations, neoORF mutations, and any combination thereof, said analyzing comprising:

identifying sequences comprising neo-antigenic mutations from the plurality of sequences comprising mutations identified in the neoplasia; and

ranking the neo-antigenic peptides encoded by the sequences comprising the neo-antigenic mutations in a ranking order of decreasing priority, the ranking order comprising:

(i) a neoORF polypeptide that binds to the HLA of the subject with a  $K_d$  of  $\leq 500$  nM encoded by a sequence comprising a neoORF mutation;

(ii) a polypeptide that binds to the HLA of the subject with a  $K_d$  of  $\leq 150$  nM encoded by a sequence comprising a missense mutation, wherein the native cognate protein has a  $K_d$  of  $\geq 1000$  nM;

(iii) a polypeptide that binds to the HLA of the subject with a  $K_d$  of  $\leq 150$  nM encoded by a sequence comprising a missense mutation, wherein the native cognate protein has a  $K_d$  of  $\leq 150$  nM;

(iv) a neoORF polypeptide that binds to the HLA of the subject with a  $K_d$  of  $> 500$  nM encoded by a sequence comprising a neoORF mutation; and

(v) a polypeptide that binds to the HLA of the subject with a  $K_d$  of  $150- \leq 500$  nM encoded by a sequence comprising a missense mutation, wherein the native cognate protein has a  $K_d$  of  $150- \leq 500$  nM; and

(d) producing, based on the identified subset, a personalized neoplasia vaccine.

18. The method of any one of claims 1 to 17, wherein the optimized subset of at least five neo-antigenic peptides and other neo-antigenic peptides have been identified as one set of plurality of sequences comprising mutations in the neoplasia through sequencing a genome, transcriptome, or proteome of the neoplasia.
19. The method of any one of claims 1 to 18, wherein the ranking order is further based on:
  - (i) one or more characteristics associated with the neo-antigenic sequences comprising mutations predicted to encode neo-antigenic peptides, the characteristics being selected from the group consisting of molecular weight, cysteine content, hydrophilicity, hydrophobicity, charge, and binding affinity; and/or
  - (ii) expression levels of the neo-antigenic sequences.
20. The method of any one of claims 1 to 19, wherein:
  - (i) the composition or personalized neoplasia vaccine comprises: (a) an optimized subset of at least 10 neo-antigenic peptides; (b) one or more DNA molecules capable of expressing the at least 10 neo-antigenic peptides; or (c) one or more RNA molecules capable of expressing the at least 10 neo-antigenic peptides; and/or
  - (ii) the composition or personalized neoplasia vaccine comprises: (a) an optimized subset of at least 20 neo-antigenic peptides; (b) one or more DNA molecules capable of expressing the at least 20 neo-antigenic peptides; or (c) one or more RNA molecules capable of expressing the at least 20 neo-antigenic peptides; and/or
  - (iii) the composition or personalized neoplasia vaccine comprises an optimized subset of at least 20 neo-antigenic peptides, wherein the at least 20 neo-antigenic peptides: (a) range from 5 to 50 amino acids in length; (b) range from 15 to 35 amino acids in length; (c) range from about 18 to about 30 amino acids in length; (d) range from about 6 to about 15 amino acids in length; or (e) are 15, 16, 17, 18, 19, 20, 21, 22, 23, 24, or 25 amino acids in length.
21. The method of any one of claims 1 to 20, further comprising:
  - (i) expressing or synthesizing the at least five neo-antigenic peptides; and/or
  - (ii) formulating a pharmaceutical composition comprising the at least five neo-antigenic peptides.

22. The method of any one of claims 1 to 21, wherein binding to the HLA is determined using a program implemented on computer system.
23. The method of any one of claims 1 to 22, wherein (i) an ability of one or more selected neo-antigenic peptides of the at least five neo-antigenic peptides to bind the protein encoded by an HLA allele expressed by the subject is unknown, or (ii) wherein an ability of T cells of the subject to bind the complex is unknown.
24. The method of any one of claims 1 to 23, wherein the composition further comprises an adjuvant.
25. The method of claim 24, wherein the adjuvant is selected from the group consisting of poly-ICLC, 1018 ISS, aluminum salts, AS15, BCG, CP-870,893, CpG7909, CyaA, GM-CSF, IC30, IC31, Imiquimod, ImuFact IMP321, IS Patch, ISS, JuvImmune, LipoVac, monophosphoryl lipid A, Montanide adjuvants, OK-432, OM-174, OM-197-MP-EC, PepTel.RTM, vector system, PLGA microparticles, resiquimod, SRL172, Virosomes and other Virus-like particles, YF-17D, VEGF trap, R848, beta-glucan, Pam3Cys, vadimezan, and AsA404 (DMXAA).
26. The method of claim 25, wherein the adjuvant is poly-ICLC.
27. The method of any one of claims 1 to 26, wherein the composition further comprises a carrier.
28. The method of any one of claims 1 to 27, wherein the neoplasia comprises a tumor selected from the group consisting of breast, ovarian, prostate, lung, kidney, gastric, colon, testicular, head and neck, acute myelogenous leukemia, chronic myelogenous leukemia, chronic lymphocytic leukemia, T cell lymphocytic leukemia, another leukemia, B cell lymphoma, another lymphoma, pancreas, brain, and melanoma.
29. Use of an immunogenic composition in the manufacture of a medicament for inducing an immune response in a subject having a neoplasia, wherein the immunogenic composition is specific to both the subject and the neoplasia, and wherein the immunogenic composition comprises: (a) an optimized subset of at least five neo-antigenic peptides identified from the subject, wherein the at least five neo-antigenic peptides collectively

have a higher ranking order than other neo-antigenic peptides identified from the subject collectively do; or (b) one or more polynucleotides encoding the at least five neo-antigenic peptides, wherein the ranking order in decreasing priority comprises:

- (i) a neoORF polypeptide that binds to the HLA of the subject with a  $K_d$  of  $\leq 500$  nM encoded by a sequence comprising a neoORF mutation;
- (ii) a polypeptide that binds to the HLA of the subject with a  $K_d$  of  $\leq 150$  nM encoded by a sequence comprising a missense mutation, wherein the native cognate protein has a  $K_d$  of  $\geq 1000$  nM;
- (iii) a polypeptide that binds to the HLA of the subject with a  $K_d$  of  $\leq 150$  nM encoded by a sequence comprising a missense mutation, wherein the native cognate protein has a  $K_d$  of  $\leq 150$  nM;
- (iv) a neoORF polypeptide that binds to the HLA of the subject with a  $K_d$  of  $> 500$  nM encoded by a sequence comprising a neoORF mutation; and
- (v) a polypeptide that binds to the HLA of the subject with a  $K_d$  of  $150- \leq 500$  nM encoded by a sequence comprising a missense mutation, wherein the native cognate protein has a  $K_d$  of  $150- \leq 500$  nM.

30. Use of a composition in the manufacture of a medicament for treating a neoplasia in a subject having the neoplasia, wherein the composition is specific to both the subject and the neoplasia, and wherein the composition comprises:
- (a) an optimized subset of at least five neo-antigenic peptides identified from the subject, wherein the at least five neo-antigenic peptides collectively have a higher ranking order than other neo-antigenic peptides identified from the subject collectively do;
  - (b) one or more polynucleotides encoding the at least five neo-antigenic peptides;
  - (c) antigen-presenting cells that have been pulsed with the at least five neo-antigenic peptides; or
  - (d) T cells from the subject that are specific to a complex of a protein encoded by an HLA allele expressed by the subject and one or more neo-epitopes of the at least five neo-antigenic peptides, wherein the T cells have been stimulated *ex vivo*

with the at least five neo-antigenic peptides, and wherein the ranking order in decreasing priority for the neo-antigenic peptides comprises:

- (i) a neoORF polypeptide that binds to the HLA of the subject with a  $K_d$  of  $\leq 500$  nM encoded by a sequence comprising a neoORF mutation;
- (ii) a polypeptide that binds to the HLA of the subject with a  $K_d$  of  $\leq 150$  nM encoded by a sequence comprising a missense mutation, wherein the native cognate protein has a  $K_d$  of  $\geq 1000$  nM;
- (iii) a polypeptide that binds to the HLA of the subject with a  $K_d$  of  $\leq 150$  nM encoded by a sequence comprising a missense mutation, wherein the native cognate protein has a  $K_d$  of  $\leq 150$  nM;
- (iv) a neoORF polypeptide that binds to the HLA of the subject with a  $K_d$  of  $> 500$  nM encoded by a sequence comprising a neoORF mutation; and
- (v) a polypeptide that binds to the HLA of the subject with a  $K_d$  of  $150- \leq 500$  nM encoded by a sequence comprising a missense mutation, wherein the native cognate protein has a  $K_d$  of  $150- \leq 500$  nM.

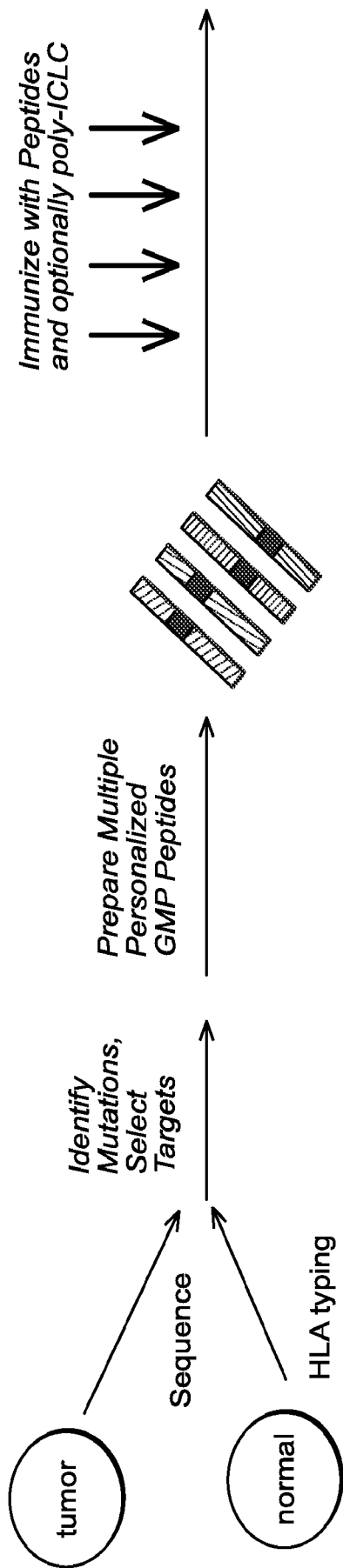

FIG. 1

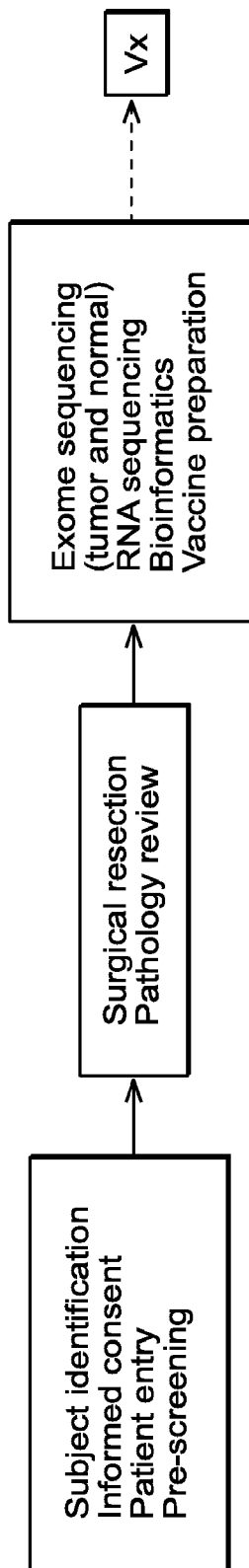

FIG. 2



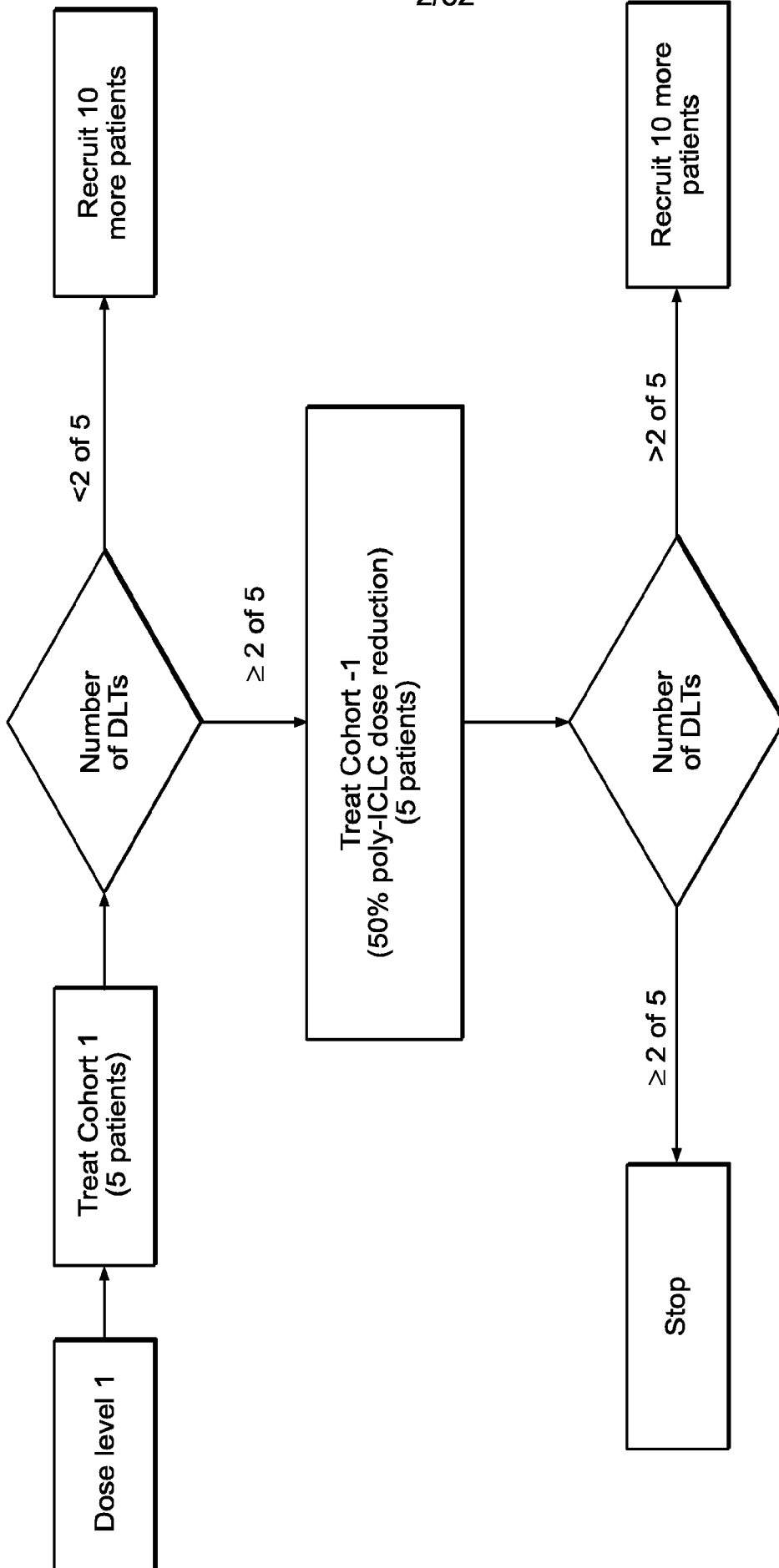

FIG. 3

2019203664 24 May 2019

3/32

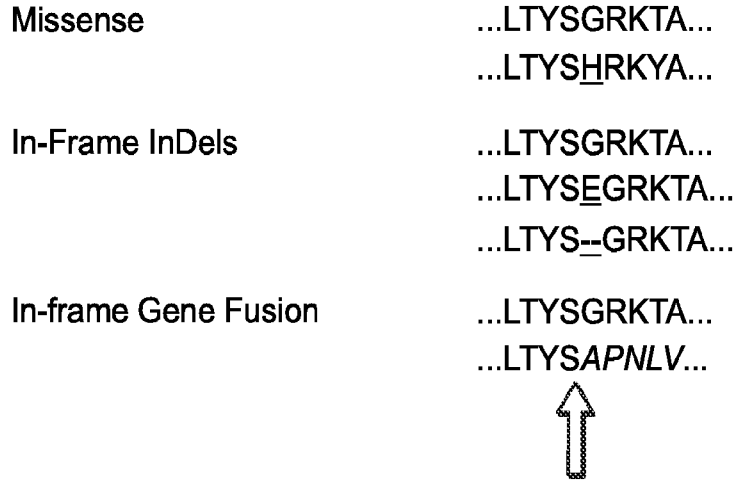

FIG. 4A

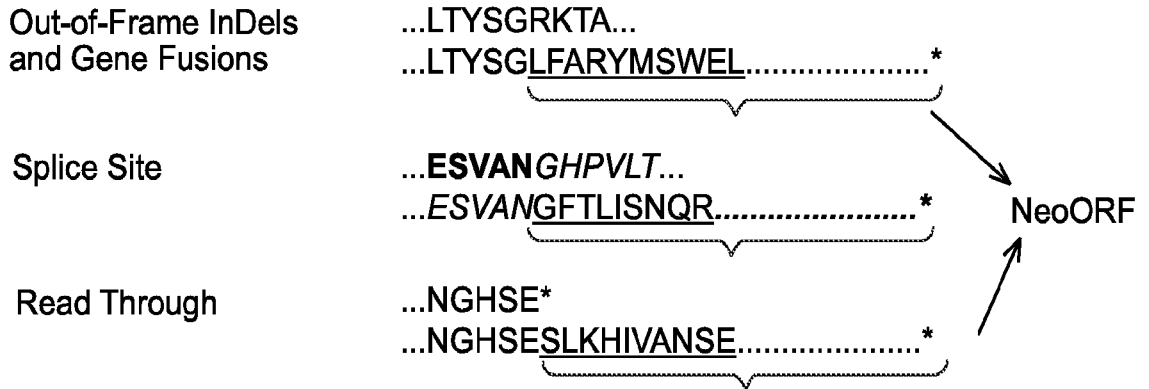

FIG. 4B

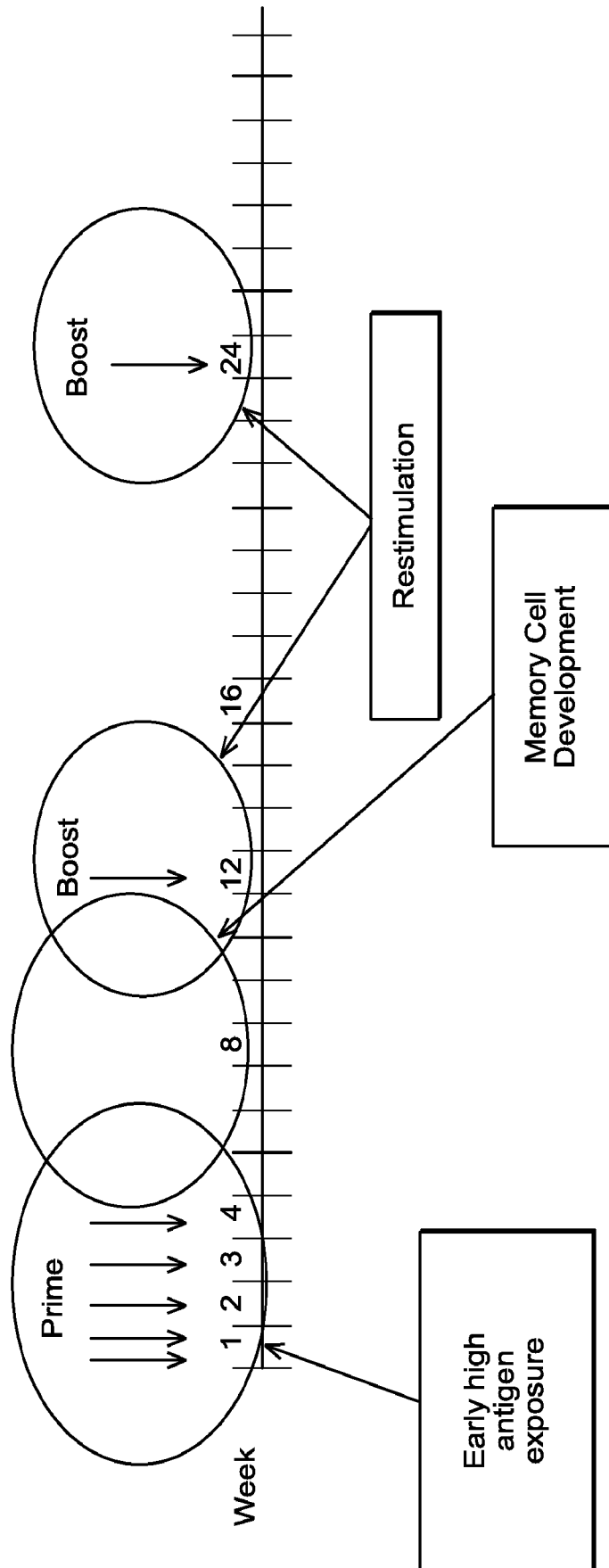

FIG. 5

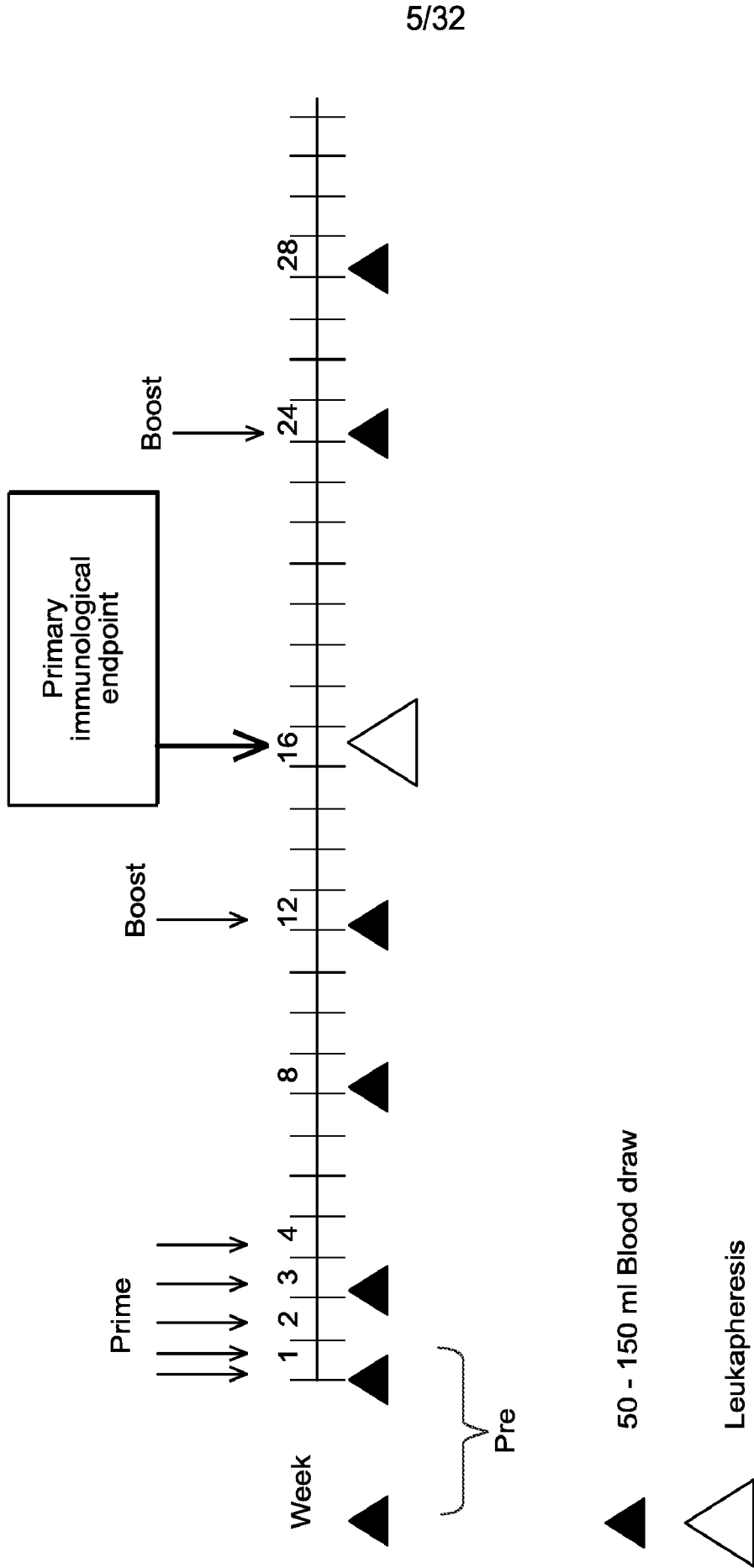

FIG. 6

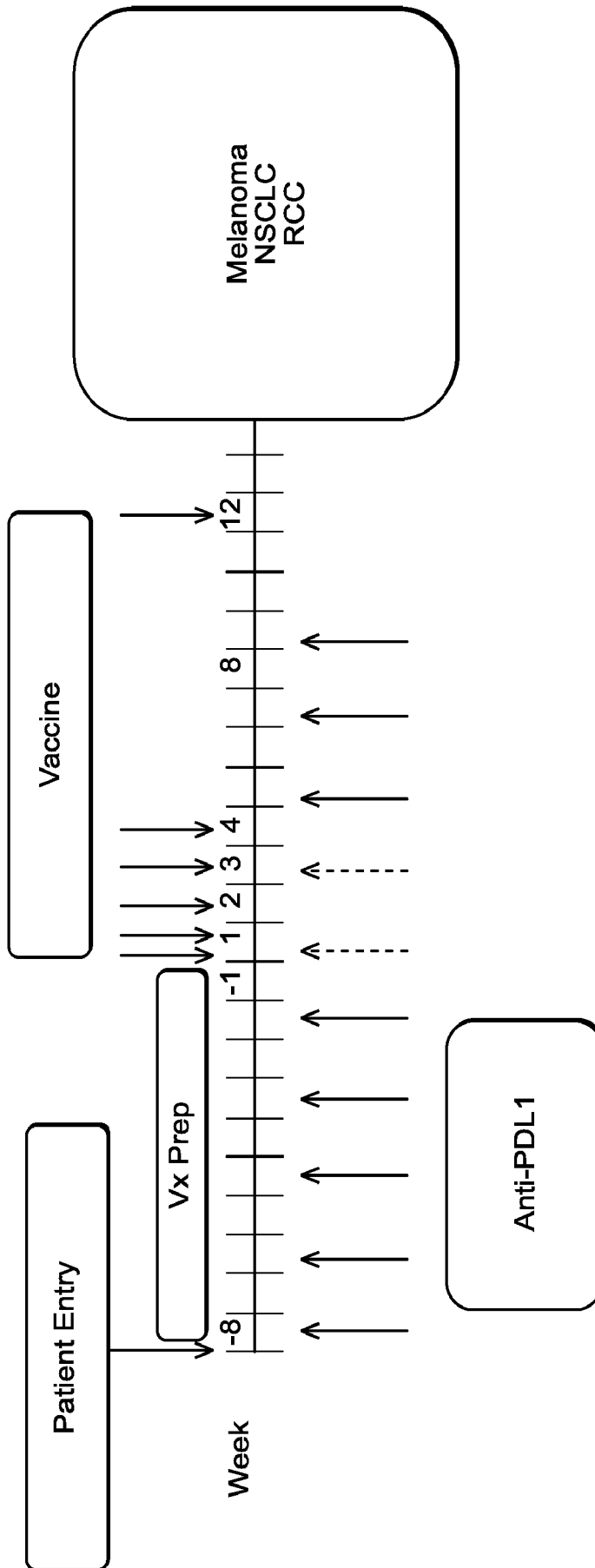

FIG. 7

CATEGORY	MUTATION TYPE	Mutant peptide Kd	Native peptide Kd	RNA LEVEL
1	NeoORF	≤ 500 nM	NA	H/M/L/-
2	Missense	≤ 150 nM	≥ 1000 nM	H/M/L
3	Missense	≤ 150 nM	≤ 150 nM	H/M/L
4	NeoORF	>500 nM	NA	H/M/L
5	Missense	150 - ≤ 500 nM	150 - ≤ 500 nM	H/M/L

FIG. 8

2019203664 24 May 2019

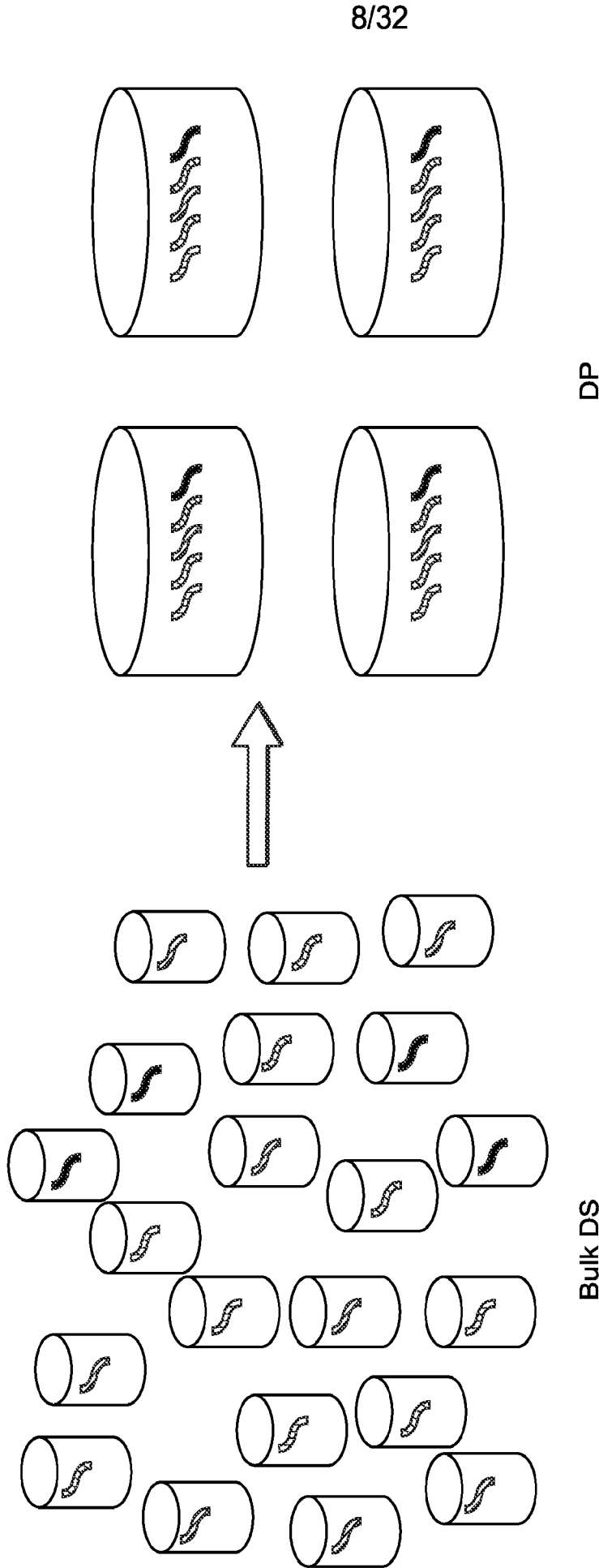

FIG. 9

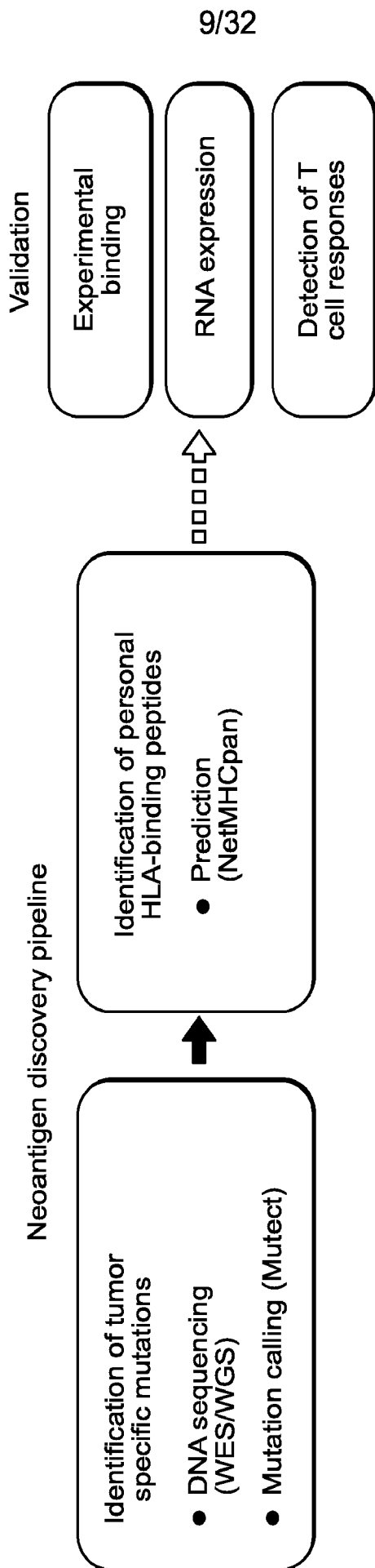

FIG. 10



2019203664 24 May 2019

10/32

Missense mutation

DNA	WT: CTTGATCGGATCGTAGCTACG Mut: CTTGA <u>A</u> CGGATCGTAGCTACG
a.a.	WT: LDRIVAT Mut: L <u>E</u> RIVAT

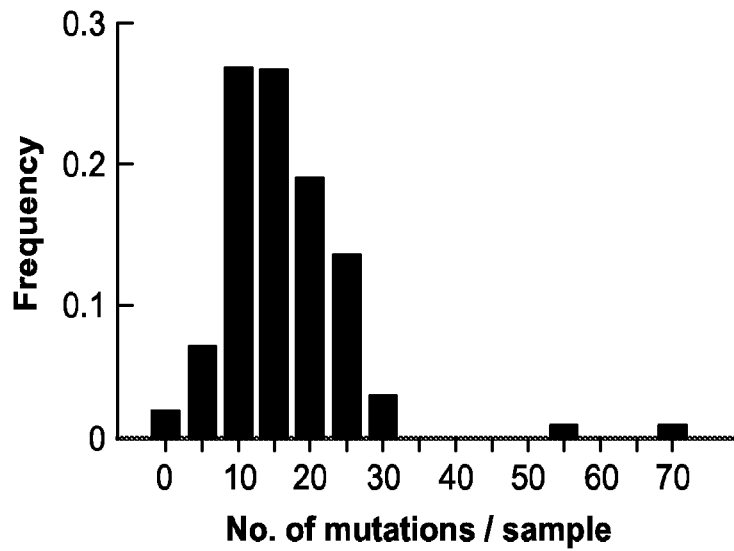
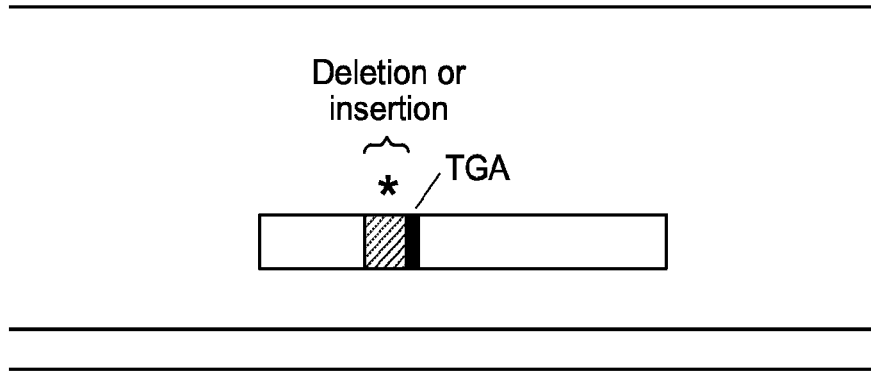

FIG. 11A

2019203664 24 May 2019

11/32

Frameshift mutations



WT: LTYSGRKTA  
Mut: LYSGLFARYMSWEL\*  
Neo ORF

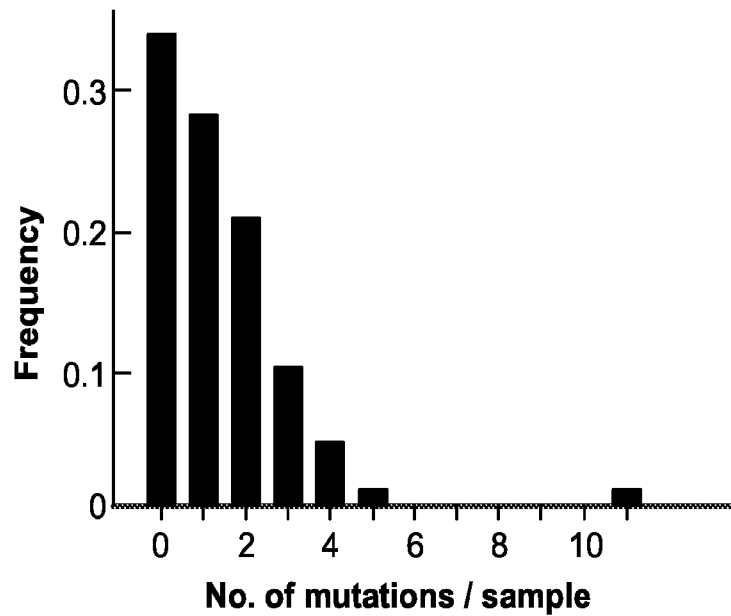

FIG. 11B

2019203664 24 May 2019

12/32

Splice site mutations

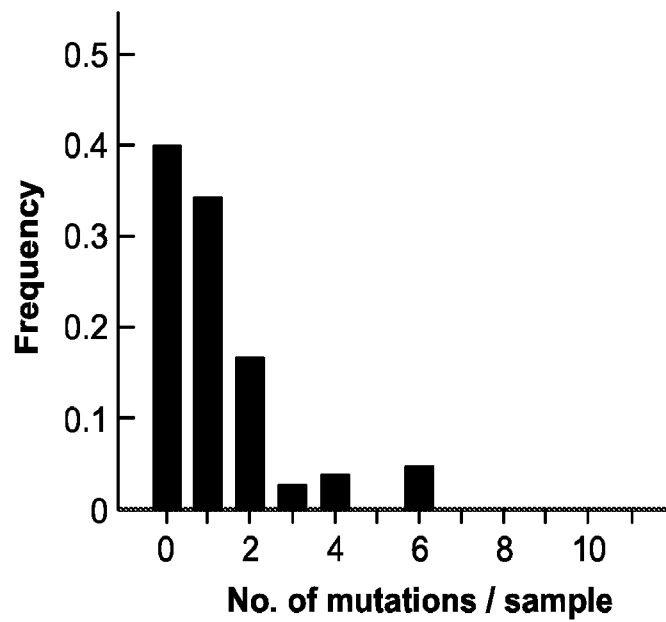
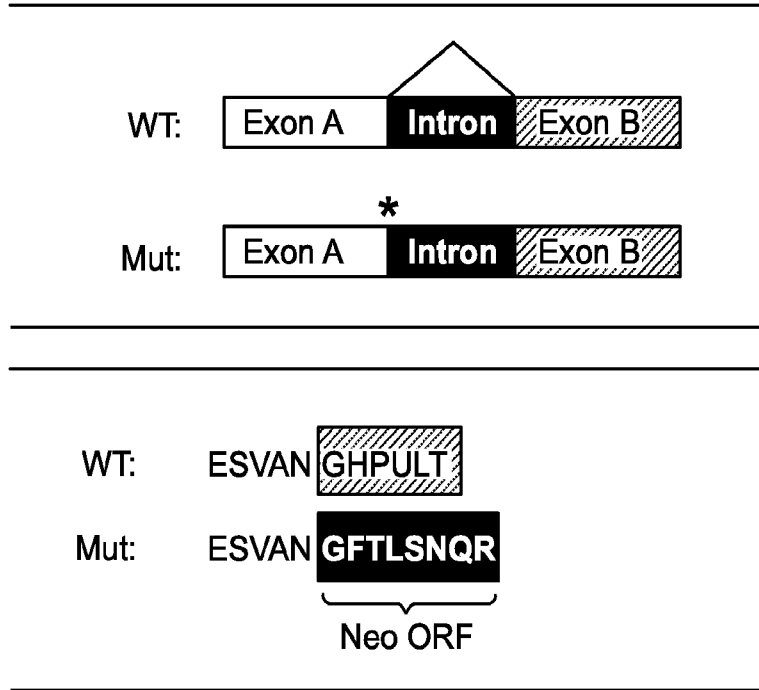

FIG. 11C

2019203664 24 May 2019

13/32

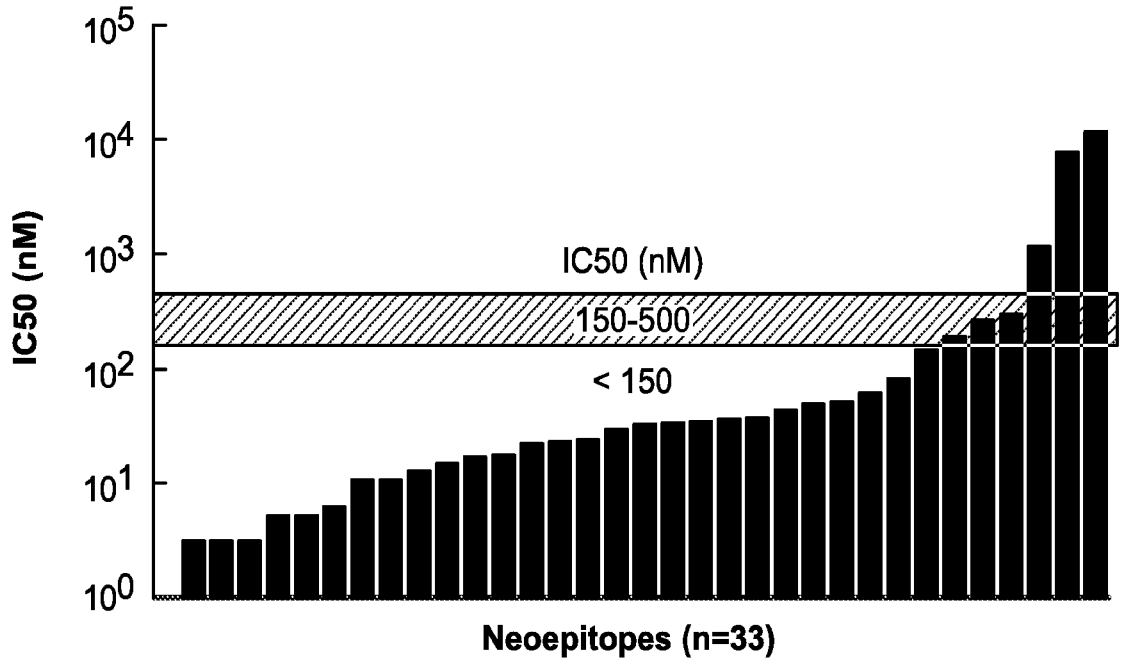

FIG. 12A

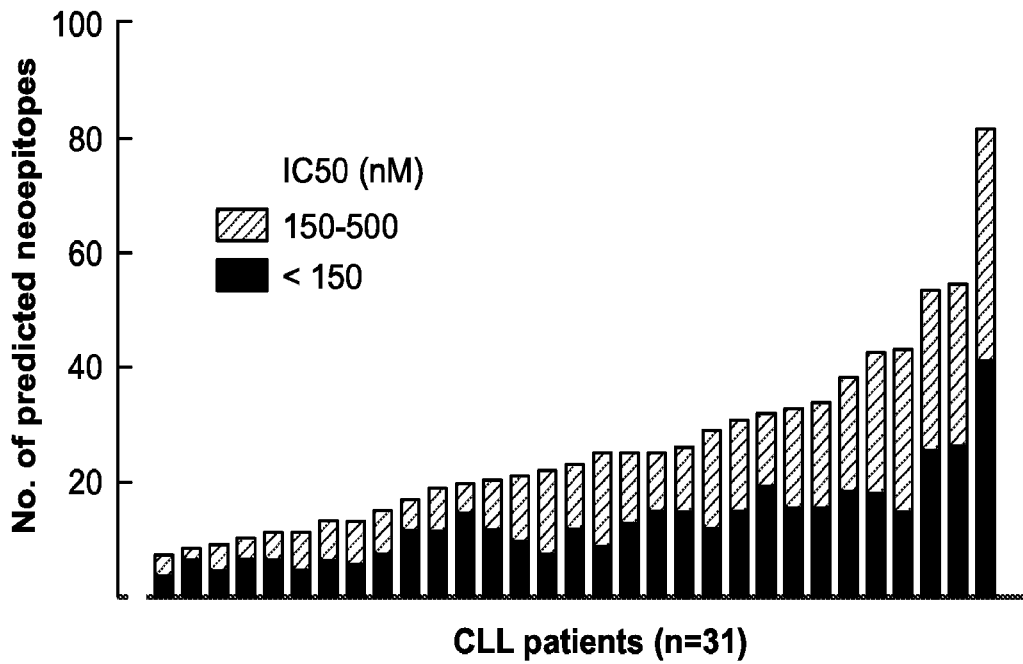

FIG. 12B

2019203664 24 May 2019

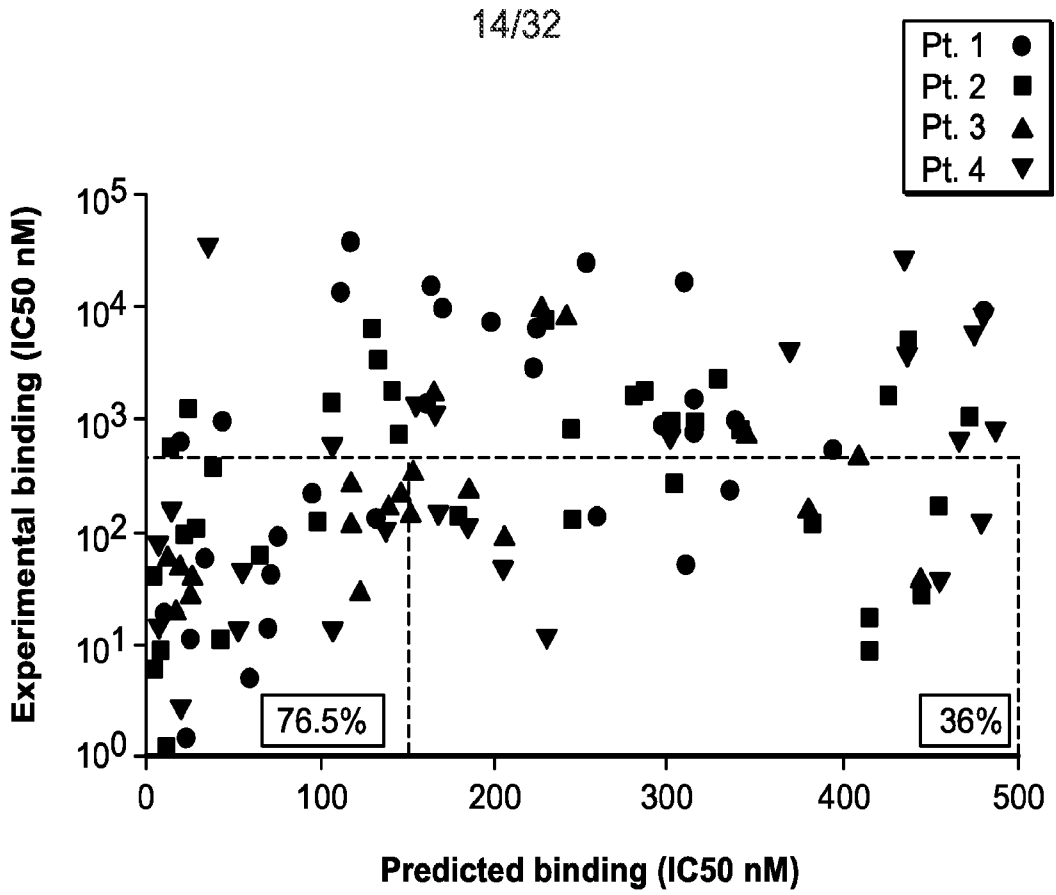
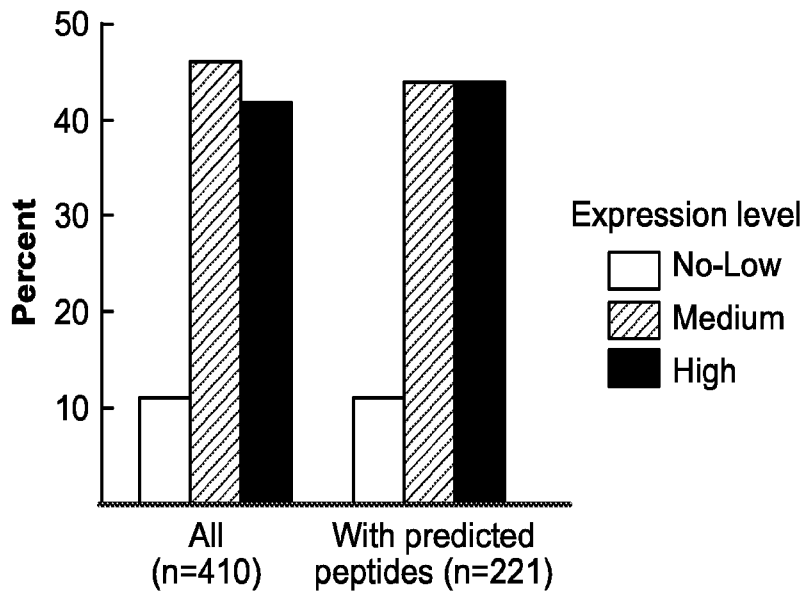

FIG. 12C



Genes with missense mutations from 28 CLLs

FIG. 12D

2019203664 24 May 2019

15/32

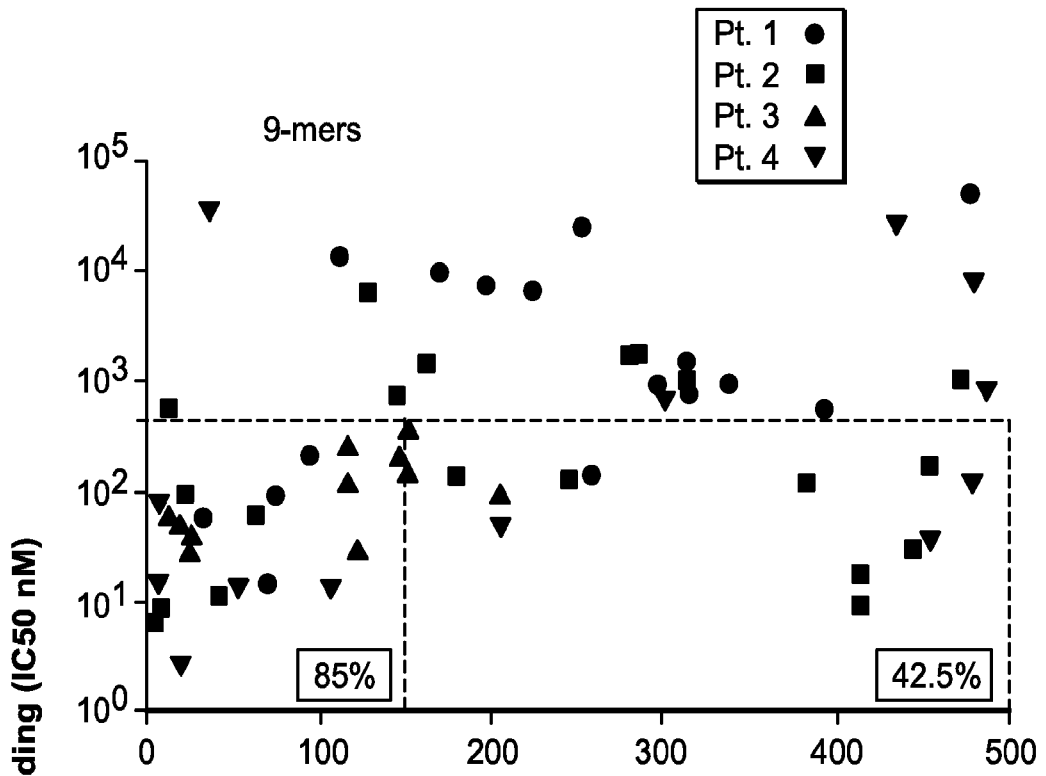

FIG. 13A

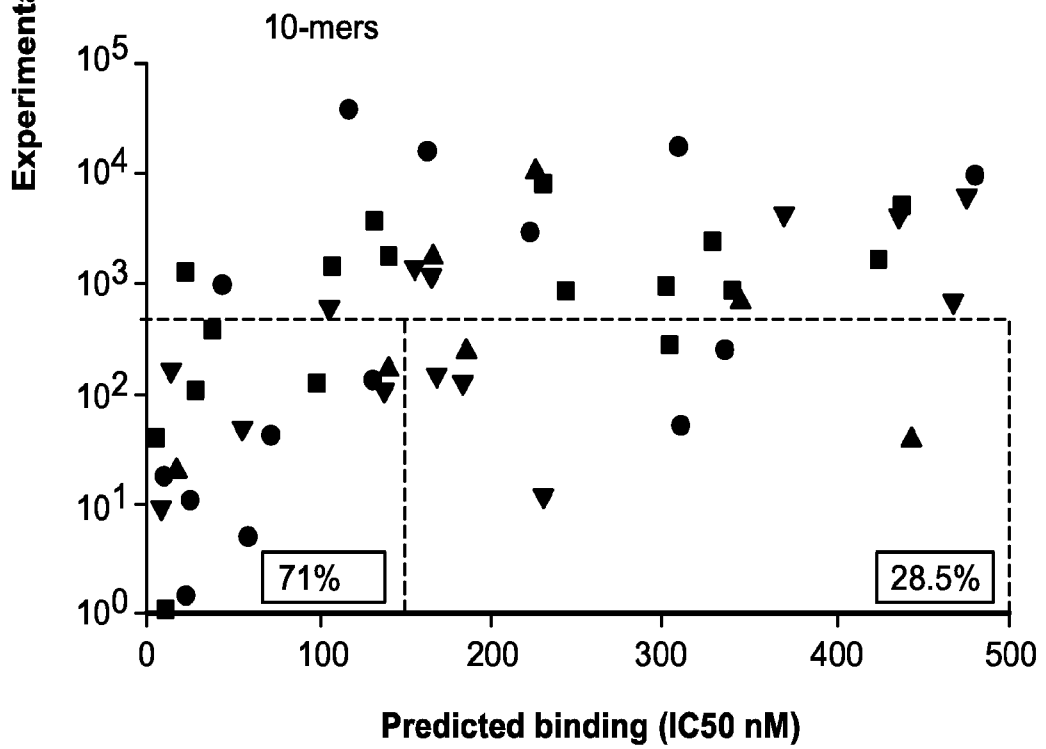
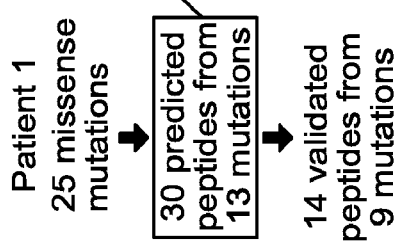

FIG. 13B

**FIG. 14A**



**FIG. 14B**

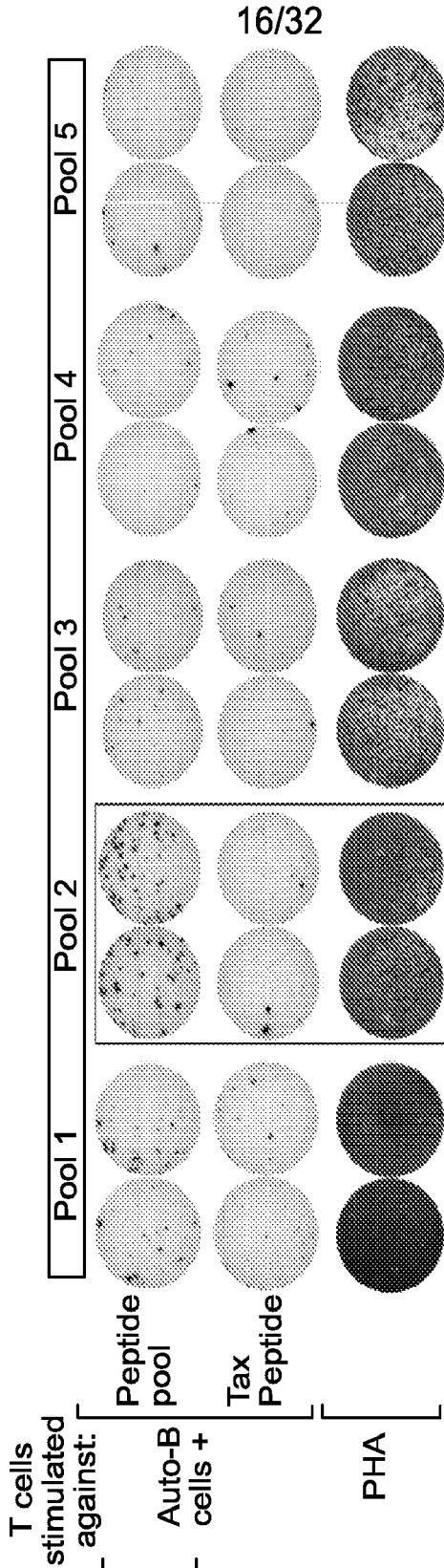
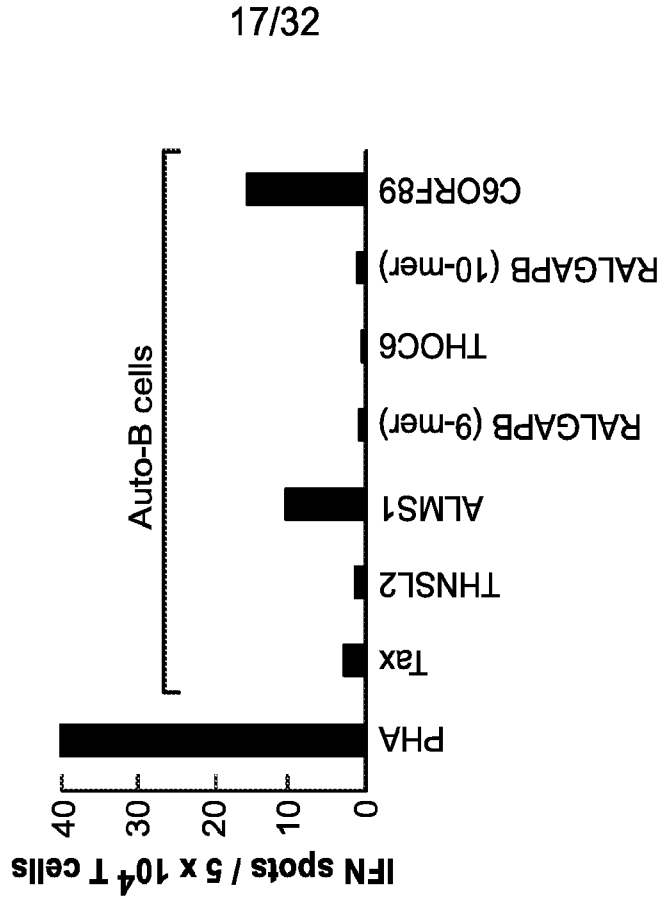

FIG. 14C

	Predicted IC50	Experimental IC50
<b>C60RF89</b> (HLA-B*35:01)		
WT: (MPIEPGDIG <b>V</b> )	2.75	1.7
Mut: (MPIEPGDIG <b>C</b> )	132.41	131
<b>ALMS1</b> (HLA-B*35:01)		
WT: (TPTVPS <b>GSF</b> )	89.33	666
Mut: (TPTVPS <b>SSF</b> )	75.28	91





**FNDC3B - VWLSWAPPV**

	241	260	280	300	320
Homo	GPGIKKTER	RARSSPKS	NDSDLQ	YELEVKRVQD	ILSGIEKPVSNIQ
Mus	GPGIKKTER	RARSSPKS	SDSDLQ	YELEVKRVQD	ILSGIEKPVSNIQ
Gallus	APGVKKPER	RARSSPKS	TEQEPHE	YDSETKRVQD	ILSGMEKPVSNIQ
Danio	KKPTRGARSSPRS	SEPELQ	HDSEAKRVQD	VLSGMEKPVSNIQ	SRTRARLTWAPPAGLQ

**ALMS1 - TPTVPSGSF**

	949	968	988	1008	1027
Homo	IPGLTDQKTVPT	TVTSGSF	SHREKPSIF	YQQEWPDS	YATEKALKVSTG
Mus	SEWLARPSEV	SEALIQAT	SETSSDLAM	SCFISQHP	LTEGLQG--K
Gallus	EIKAE	LLLSAKK	SGQAKG	TRSYSS	LAAASVYSCN
Danio					

**C6ORF89 - MPIEPGDIGY**

	241	260	280	300	320
Homo	LPFPK--	DA	SLNKC	SFLHPE	PVVGSKMHKMPD
Mus	LPFPK--	DS	SLNKC	FLIQPE	PVVGSKMHKVHD
Gallus	LSFPK--	TV	SLNKC	FLIR	-HPDLGNKSYSLHS
Danio	CPLLEIWS	STLQ	CRCLR	SSRRPQ--	PSRVQVLGWMVVAD

**FIG. 15**

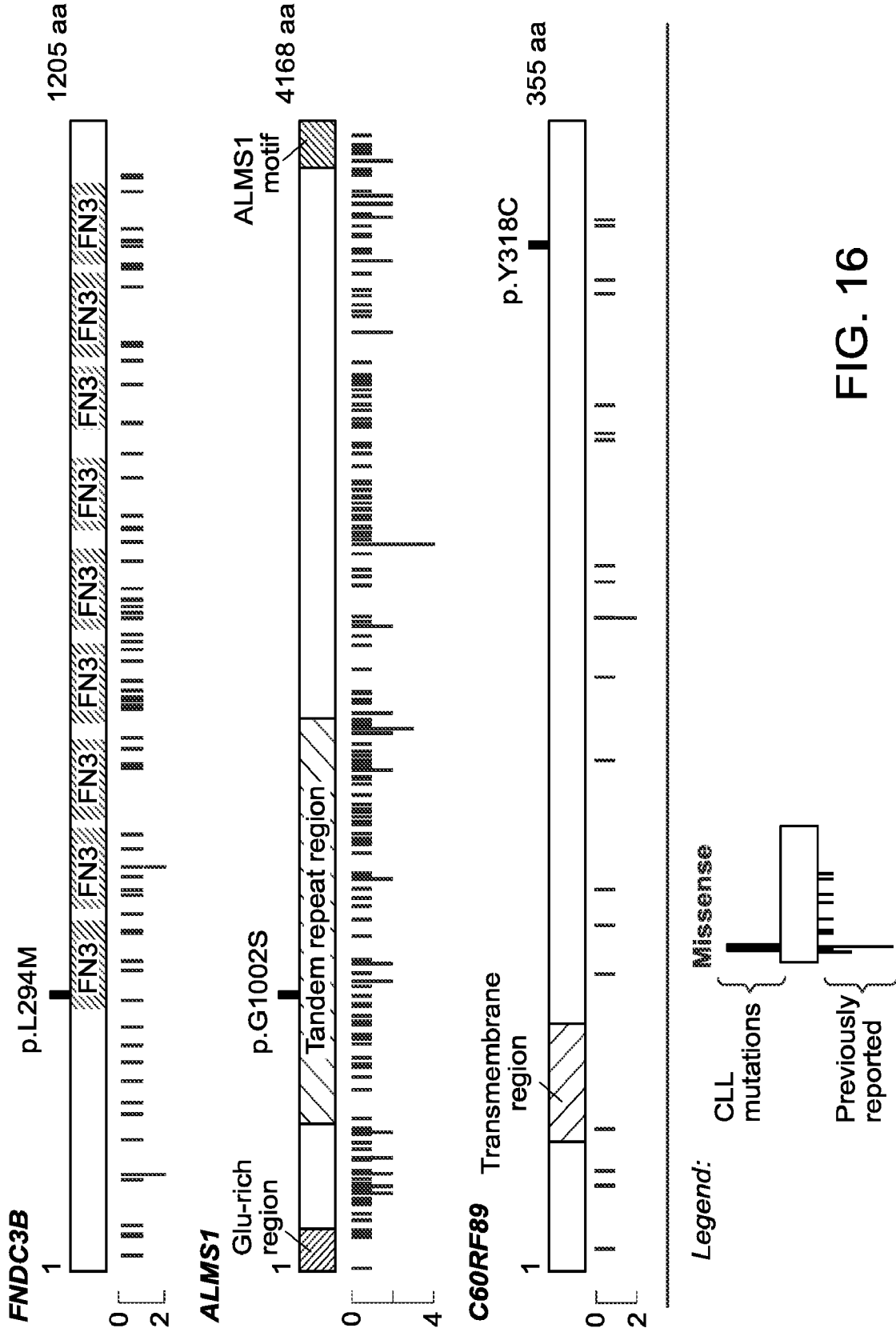

FIG. 16

FIG. 17A

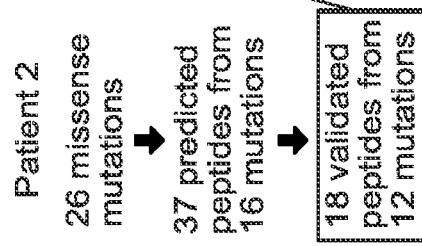

FIG. 17B

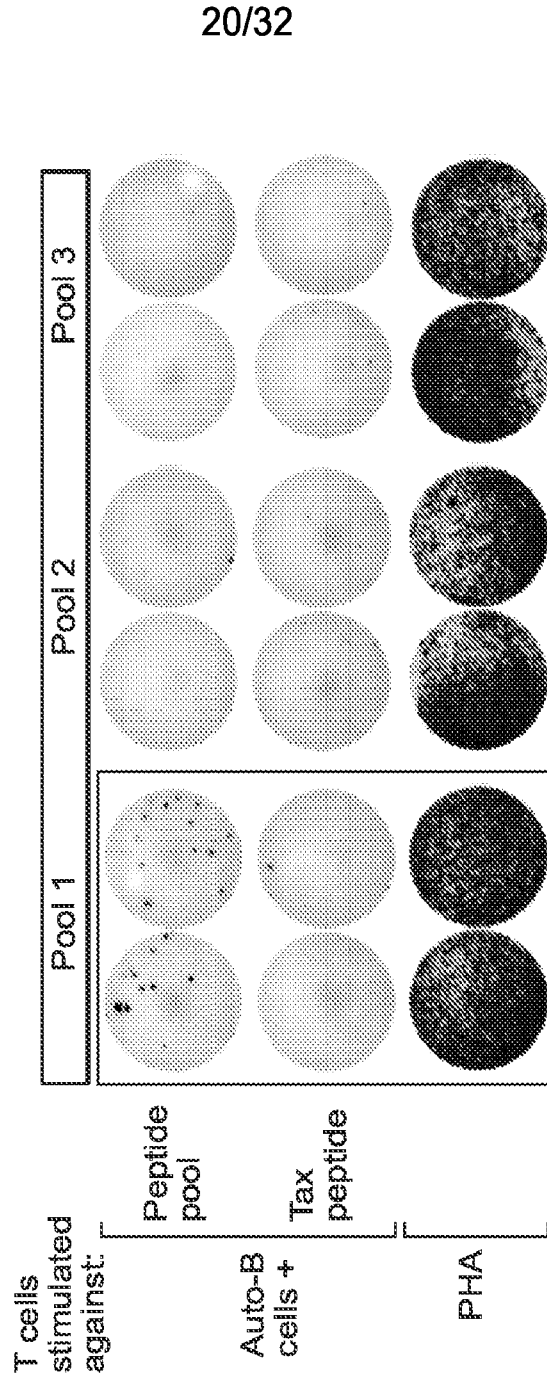
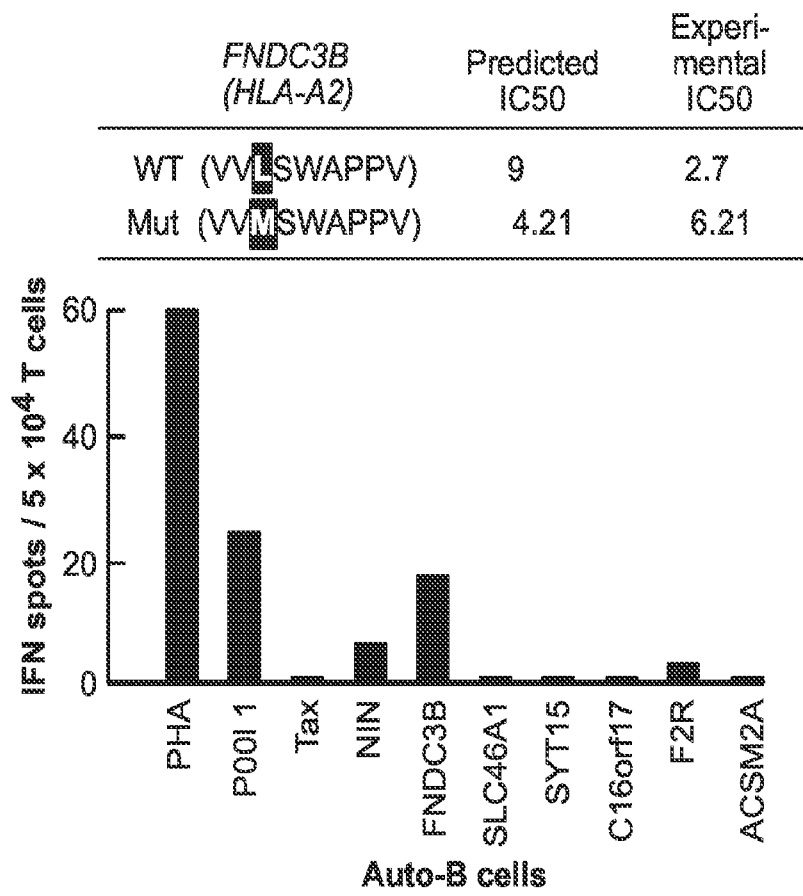

FIG. 17C



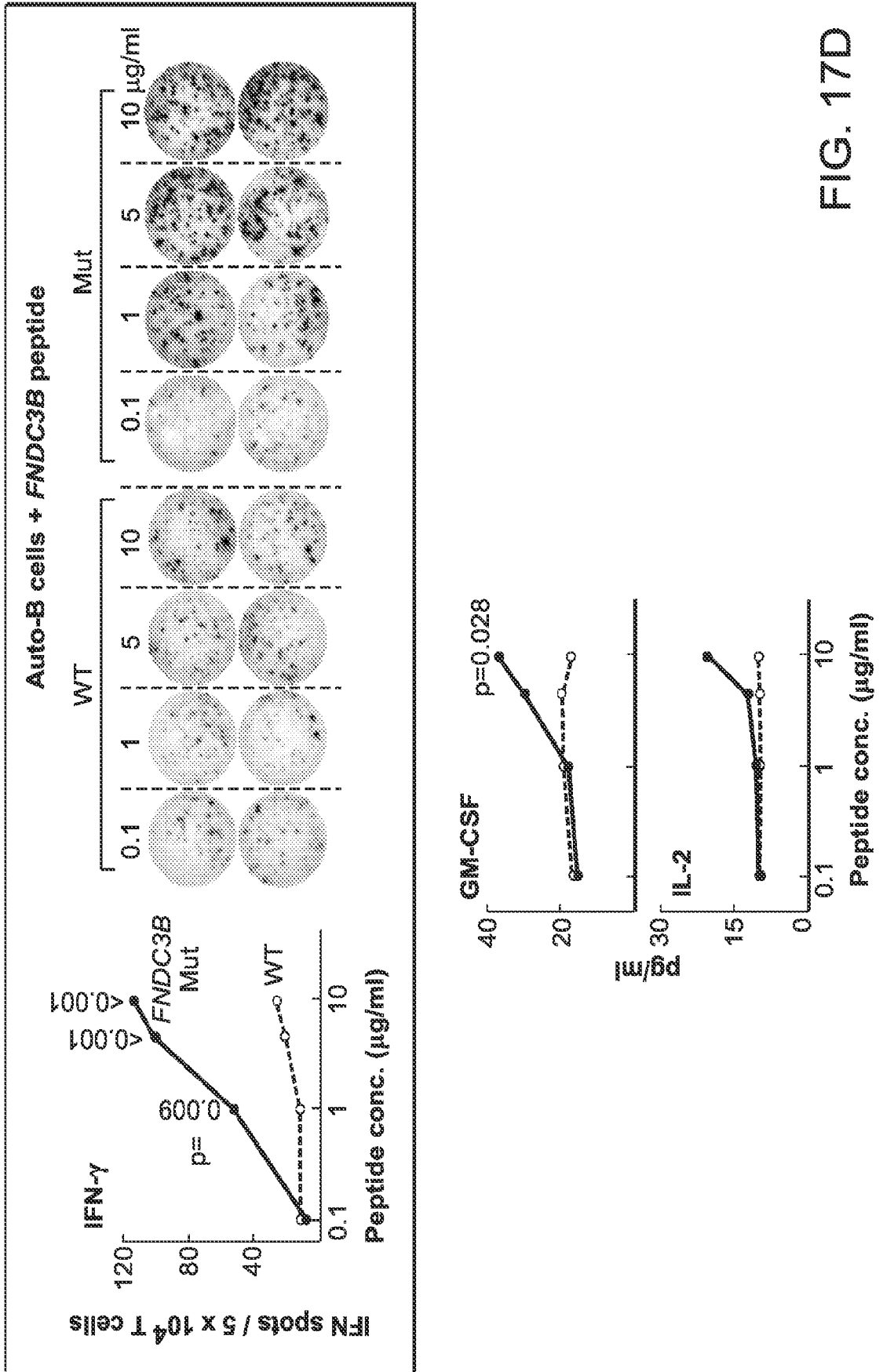

FIG. 17D

FIG. 17E

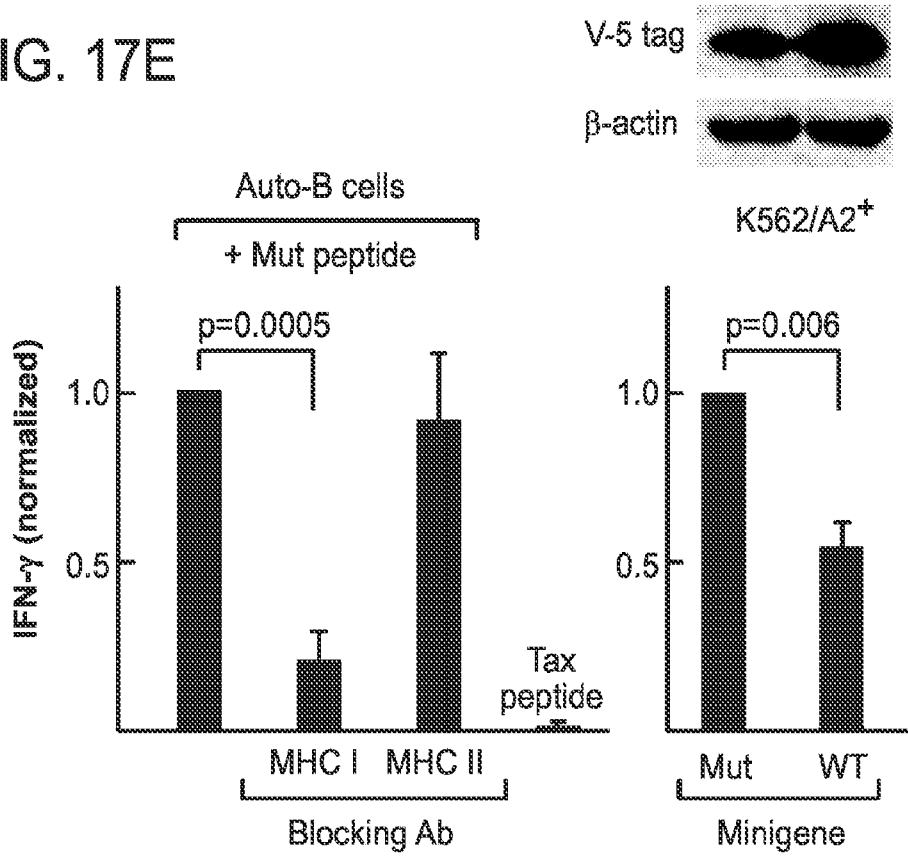

FIG. 17F

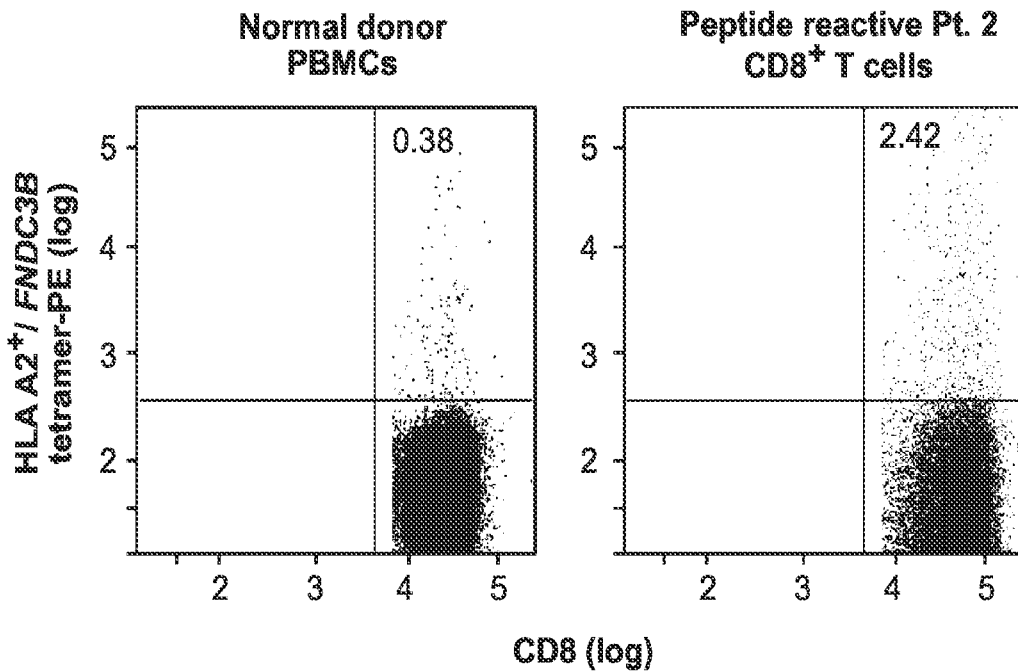
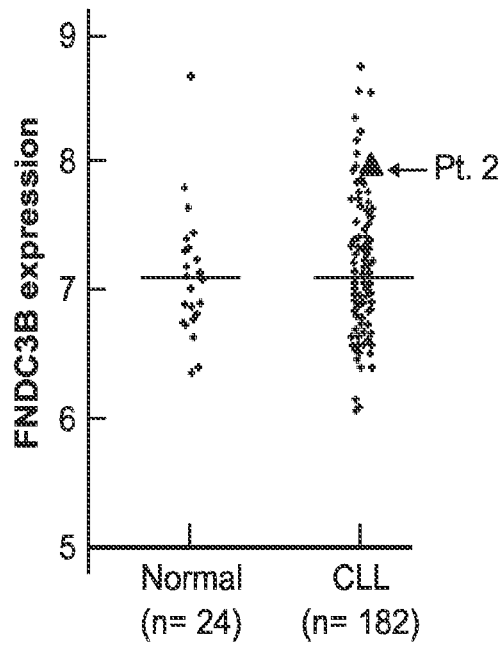

FIG. 17G



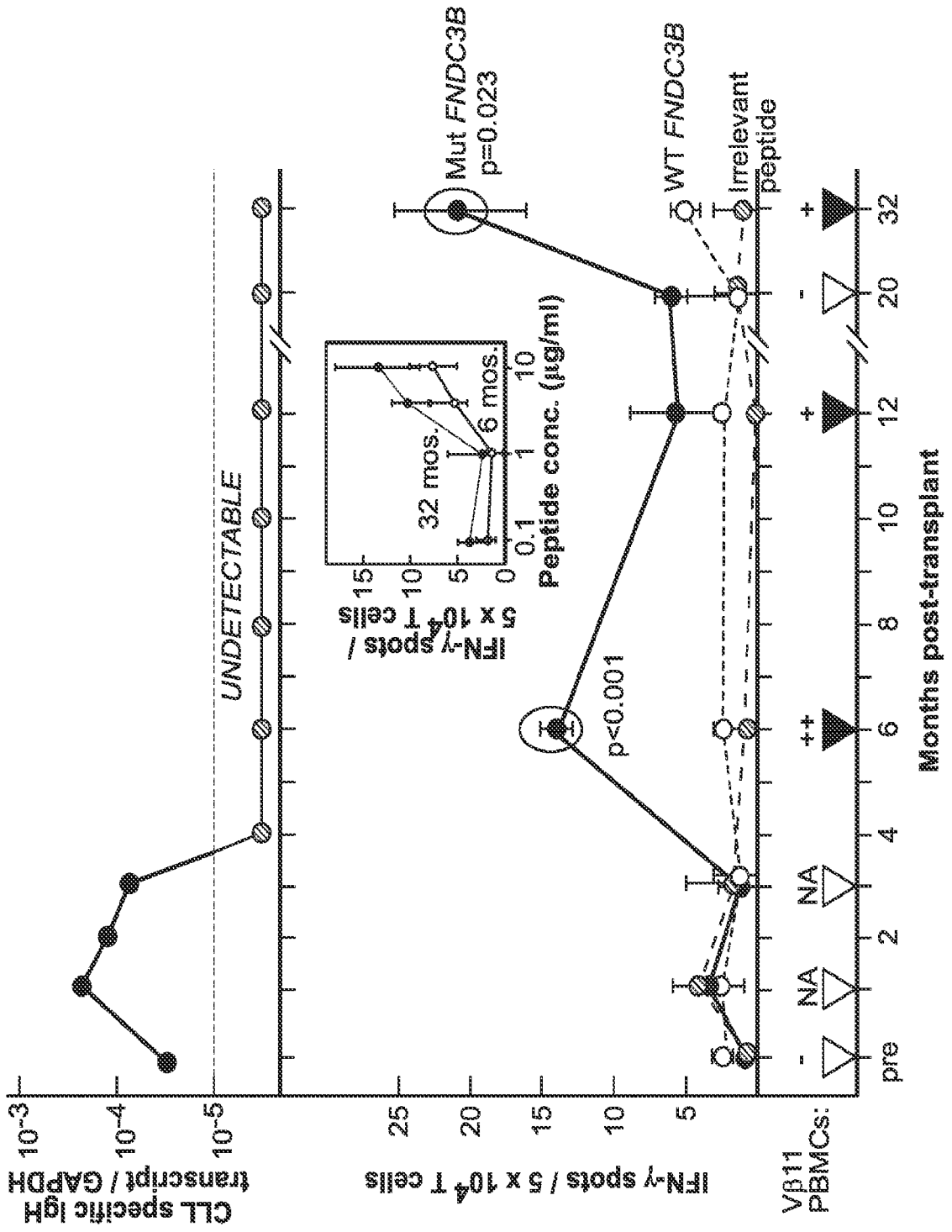

FIG. 18



2019203664 24 May 2019

FIG. 19A

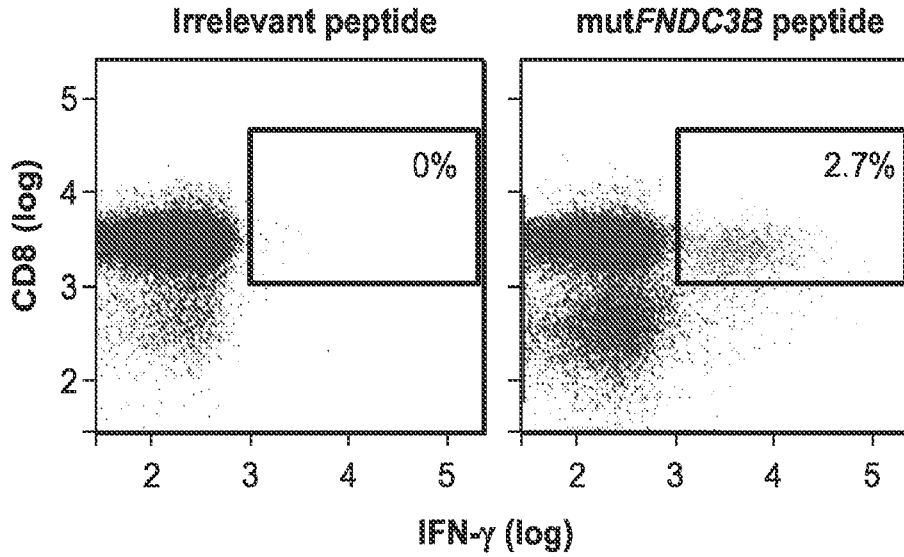

FIG. 19B

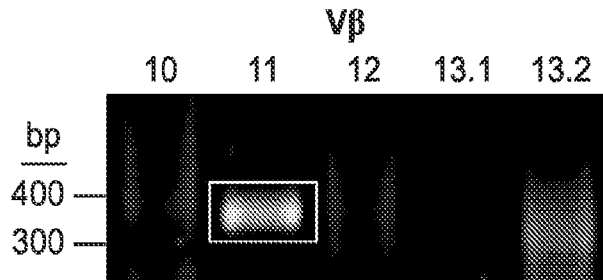

FIG. 19C

V $\beta$ 11

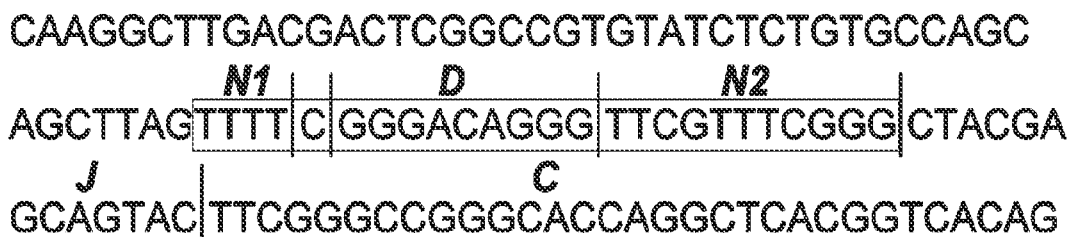
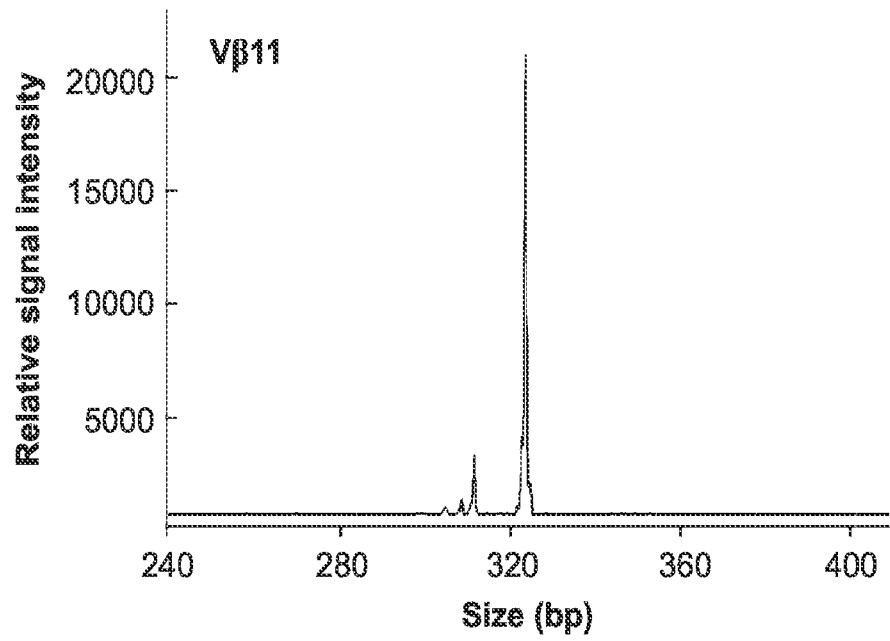

FIG. 19D



2019203664 24 May 2019

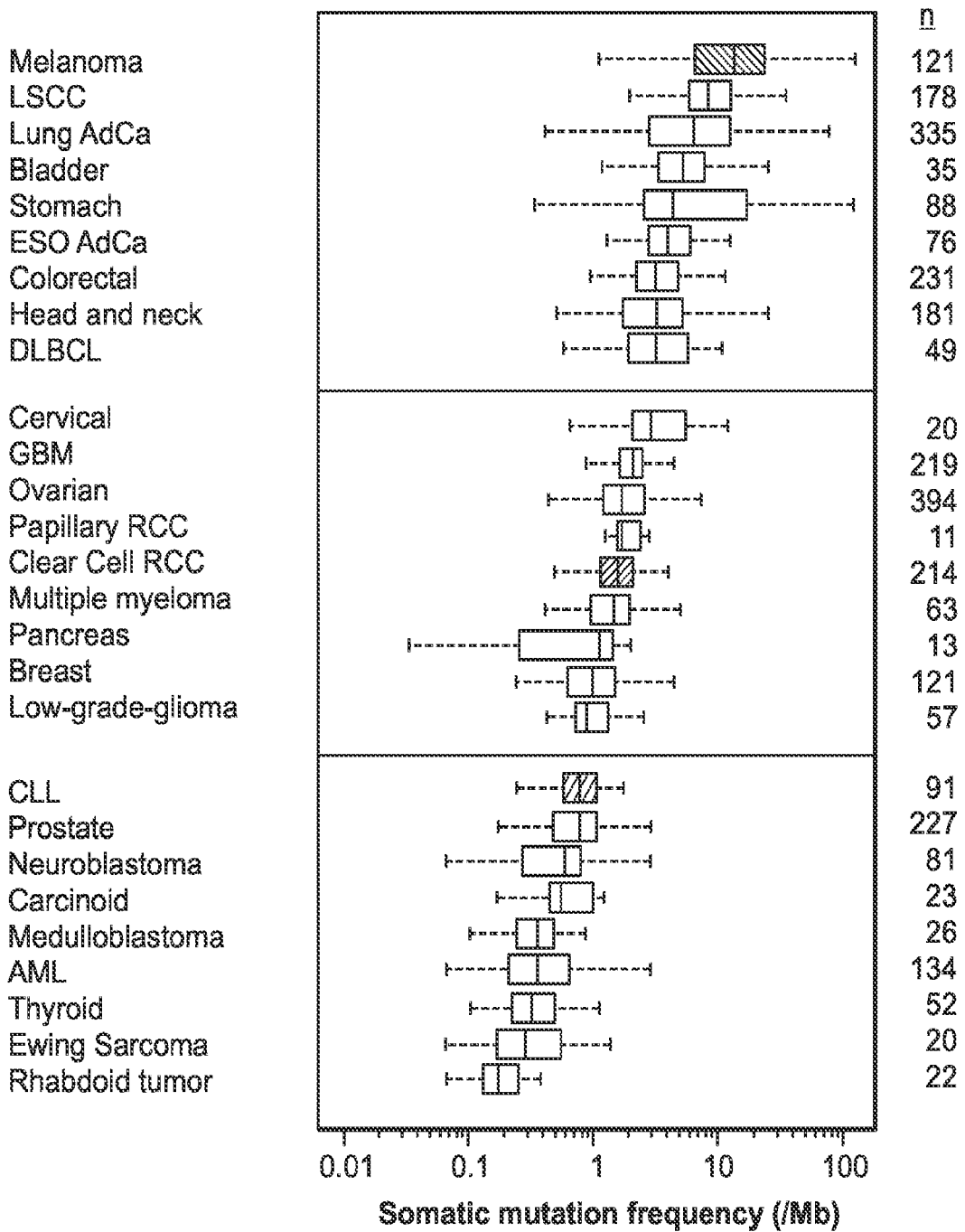
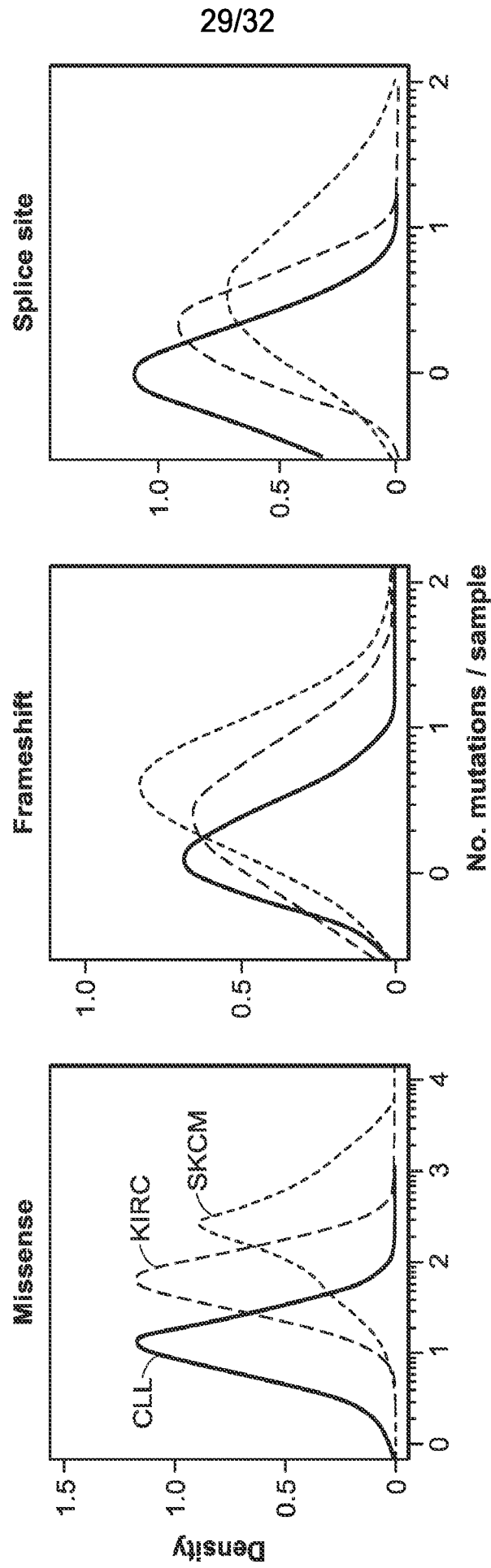

FIG. 20A

FIG. 20B



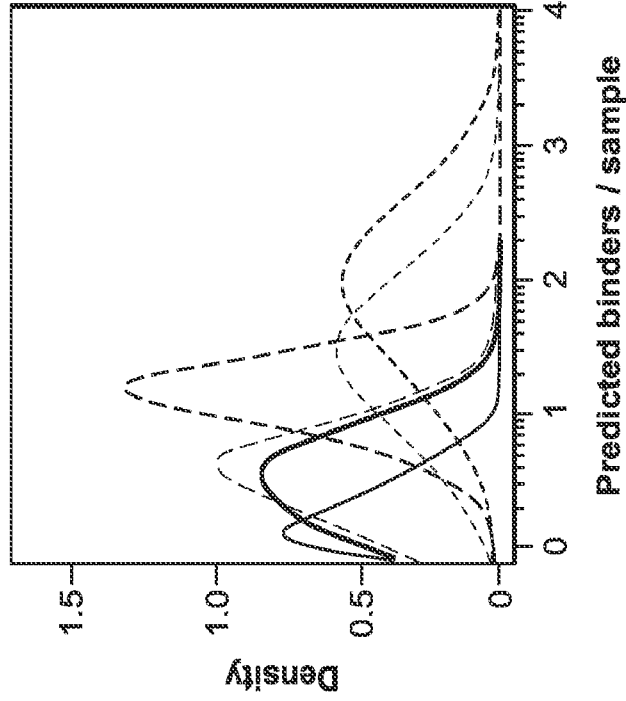

FIG. 20D

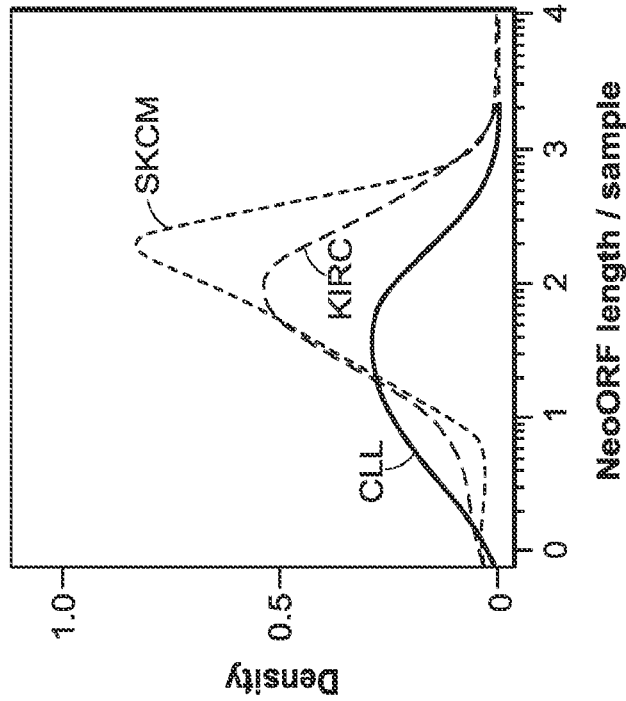

FIG. 20C

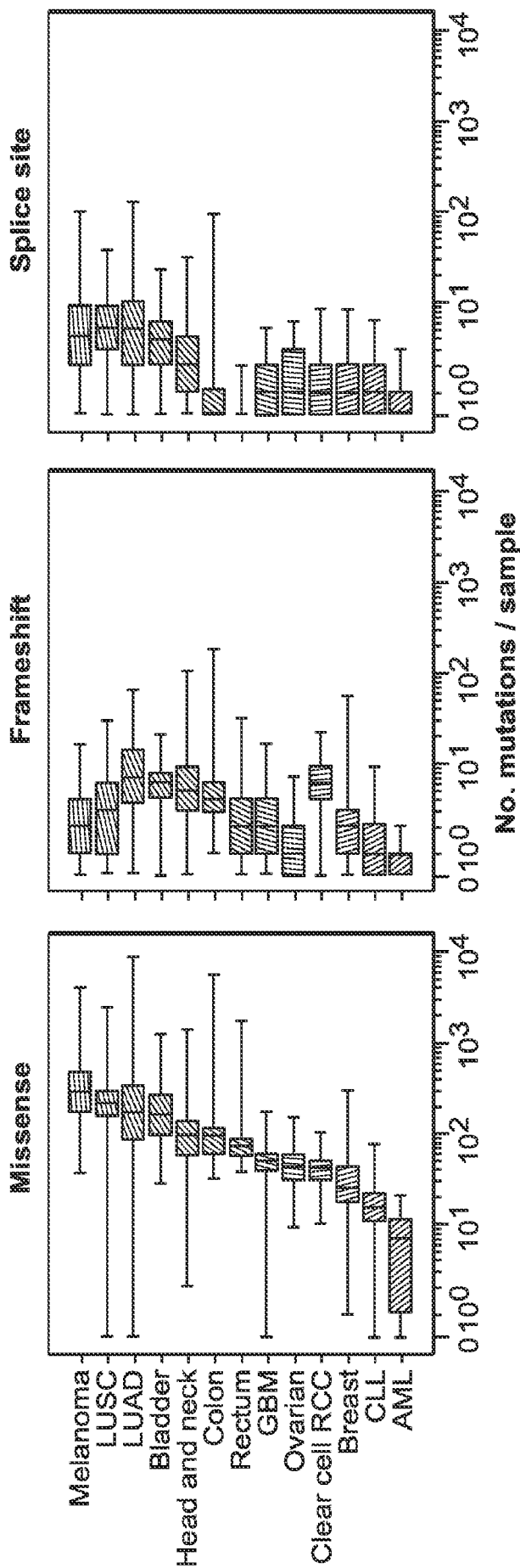

FIG. 20E

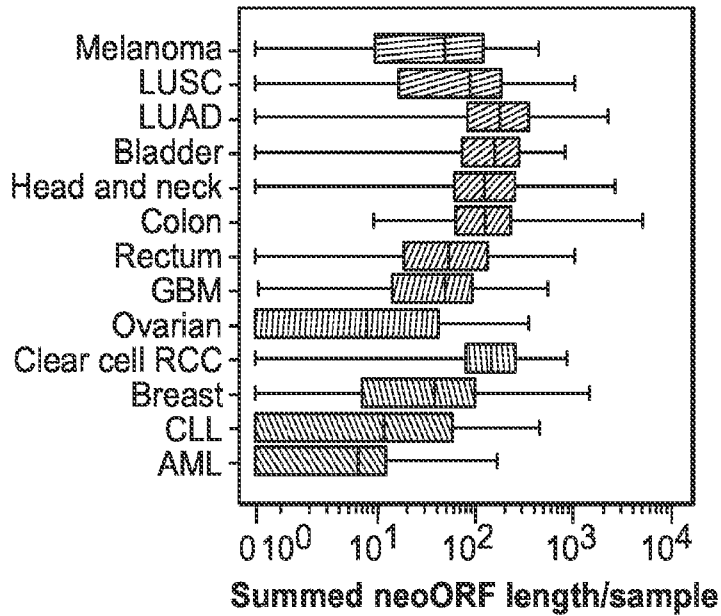

FIG. 20F

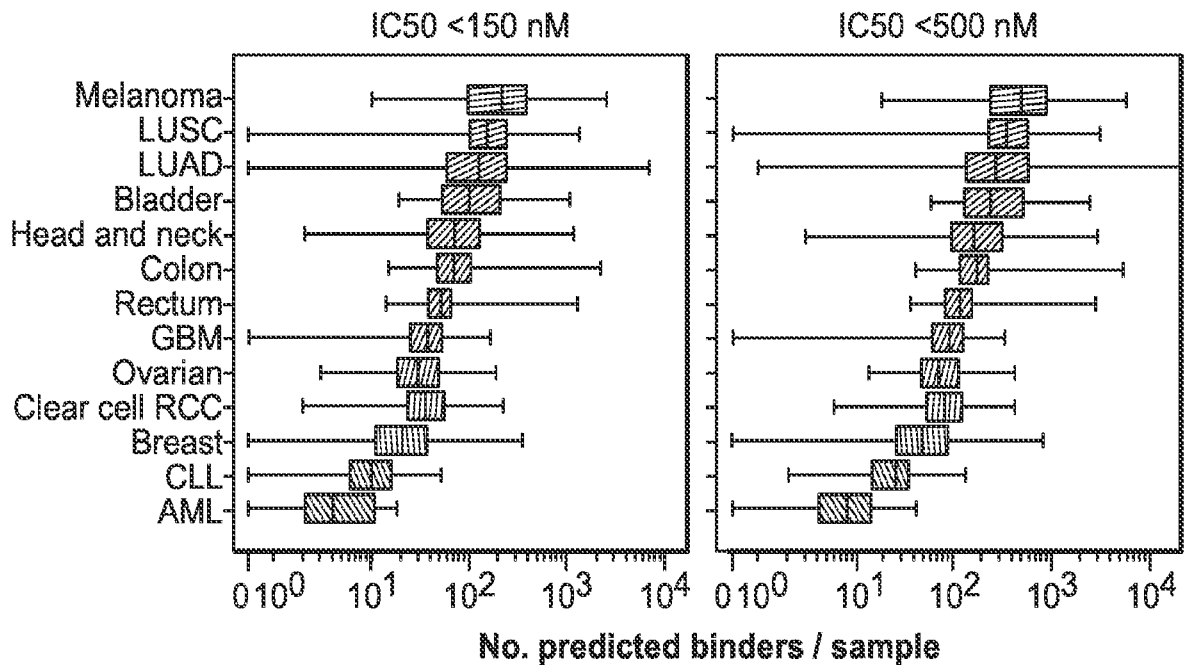

FIG. 20G

2019203664 24 May 2019

47608992002  
SEQUENCE LISTING

<110> THE BROAD INSTITUTE, INC.  
<120> COMPOSITIONS AND METHODS FOR PERSONALIZED NEOPLASIA VACCINES  
<130> 92784wo(314024)  
<140> PCT/US2014/033185  
<141> 2014-04-07  
<150> 61/869,721  
<151> 2013-08-15  
<150> 61/809,406  
<151> 2013-04-07  
<160> 338  
<170> PatentIn version 3.5  
<210> 1  
<211> 6  
<212> PRT  
<213> Artificial Sequence  
  
<220>  
<221> source  
<223> /note="Description of Artificial Sequence: Synthetic  
6xHis tag"  
  
<400> 1  
His His His His His His  
1 5  
  
<210> 2  
<211> 9  
<212> PRT  
<213> Homo sapiens  
  
<400> 2  
Phe Leu Asp Glu Phe Met Glu Gly Val  
1 5  
  
<210> 3  
<211> 10  
<212> PRT  
<213> Homo sapiens  
  
<400> 3  
Leu Thr Asp Asp Arg Leu Phe Thr Cys Tyr  
1 5 10  
  
<210> 4  
<211> 10  
<212> PRT  
<213> Homo sapiens  
  
<400> 4  
Leu Leu Leu Asp Asp Leu Leu Val Ser Ile  
1 5 10  
  
<210> 5  
<211> 9



2019203664 24 May 2019

47608992002

<212> PRT  
<213> Homo sapiens

<400> 5  
Lys Thr Leu Thr Ser Val Phe Gln Lys  
1 5

<210> 6  
<211> 9  
<212> PRT  
<213> Homo sapiens

<400> 6  
Glu Ala Phe Ile Gln Pro Ile Thr Arg  
1 5

<210> 7  
<211> 9  
<212> PRT  
<213> Homo sapiens

<400> 7  
Arg Pro His Val Pro Glu Ser Ala Phe  
1 5

<210> 8  
<211> 10  
<212> PRT  
<213> Homo sapiens

<400> 8  
Ser Leu Ala Asp Glu Ala Glu Val Tyr Leu  
1 5 10

<210> 9  
<211> 9  
<212> PRT  
<213> Homo sapiens

<400> 9  
Lys Ile Phe Ser Glu Val Thr Leu Lys  
1 5

<210> 10  
<211> 9  
<212> PRT  
<213> Homo sapiens

<400> 10  
Glu Thr Val Ser Glu Gln Ser Asn Val  
1 5

<210> 11  
<211> 10  
<212> PRT  
<213> Homo sapiens

<400> 11  
Gly Ile Val Glu Gly Leu Ile Thr Thr Val  
1 5 10

<210> 12  
 <211> 10  
 <212> PRT  
 <213> Homo sapiens

<400> 12  
 Ser Leu Phe Glu Gly Ile Asp Ile Tyr Thr  
 1 5 10

<210> 13  
 <211> 10  
 <212> PRT  
 <213> Homo sapiens

<400> 13  
 Phe Ile Ala Ser Asn Gly Val Lys Leu Val  
 1 5 10

<210> 14  
 <211> 9  
 <212> PRT  
 <213> Homo sapiens

<400> 14  
 Cys Ile Leu Gly Lys Leu Phe Thr Lys  
 1 5

<210> 15  
 <211> 9  
 <212> PRT  
 <213> Homo sapiens

<400> 15  
 Gln Thr Ala Cys Glu Val Leu Asp Tyr  
 1 5

<210> 16  
 <211> 9  
 <212> PRT  
 <213> Homo sapiens

<400> 16  
 Ile Leu Asn Ala Met Ile Ala Lys Ile  
 1 5

<210> 17  
 <211> 9  
 <212> PRT  
 <213> Homo sapiens

<400> 17  
 Tyr Thr Asp Phe His Cys Gln Tyr Val  
 1 5

<210> 18  
 <211> 11  
 <212> PRT  
 <213> Homo sapiens

<400> 18  
 Ser Glu Leu Phe Arg Ser Gly Leu Asp Ser Tyr  
 1 5 10

24 May 2019

2019203664

<210> 19  
 <211> 9  
 <212> PRT  
 <213> Homo sapiens

<400> 19  
 Ala Glu Pro Ile Asp Ile Gln Thr Trp  
 1 5

<210> 20  
 <211> 10  
 <212> PRT  
 <213> Homo sapiens

<400> 20  
 Thr Leu Asp Trp Leu Leu Gln Thr Pro Lys  
 1 5 10

<210> 21  
 <211> 10  
 <212> PRT  
 <213> Homo sapiens

<400> 21  
 Gly Leu Phe Gly Asp Ile Tyr Leu Ala Ile  
 1 5 10

<210> 22  
 <211> 9  
 <212> PRT  
 <213> Homo sapiens

<400> 22  
 Ile Leu Asp Lys Val Leu Val His Leu  
 1 5

<210> 23  
 <211> 9  
 <212> PRT  
 <213> Homo sapiens

<400> 23  
 Ser Tyr Leu Asp Ser Gly Ile His Phe  
 1 5

<210> 24  
 <211> 10  
 <212> PRT  
 <213> Homo sapiens

<400> 24  
 Lys Ile Leu Asp Ala Val Val Ala Gln Lys  
 1 5 10

<210> 25  
 <211> 9  
 <212> PRT  
 <213> Homo sapiens

<400> 25

2019203664 24 May 2019

47608992002

Lys Glu Leu Glu Gly Ile Leu Leu Leu  
1 5

<210> 26  
<211> 9  
<212> PRT  
<213> Homo sapiens

<400> 26  
Lys Ile Asn Lys Asn Pro Lys Tyr Lys  
1 5

<210> 27  
<211> 11  
<212> PRT  
<213> Homo sapiens

<400> 27  
Phe Leu Glu Gly Asn Glu Val Gly Lys Thr Tyr  
1 5 10

<210> 28  
<211> 9  
<212> PRT  
<213> Homo sapiens

<400> 28  
Ala Gln Gln Ile Thr Lys Thr Glu Val  
1 5

<210> 29  
<211> 10  
<212> PRT  
<213> Homo sapiens

<400> 29  
Ala Cys Asp Pro His Ser Gly His Phe Val  
1 5 10

<210> 30  
<211> 9  
<212> PRT  
<213> Homo sapiens

<400> 30  
Phe Leu Asp Glu Phe Met Glu Ala Val  
1 5

<210> 31  
<211> 10  
<212> PRT  
<213> Homo sapiens

<400> 31  
Leu Thr Asp Asp Arg Leu Phe Thr Cys His  
1 5 10

<210> 32  
<211> 10  
<212> PRT  
<213> Homo sapiens

<400> 32  
 Leu Leu Leu Asp Asp Ser Leu Val Ser Ile  
 1 5 10

<210> 33  
 <211> 9  
 <212> PRT  
 <213> Homo sapiens

<400> 33  
 Glu Thr Leu Thr Ser Val Phe Gln Lys  
 1 5

<210> 34  
 <211> 9  
 <212> PRT  
 <213> Homo sapiens

<400> 34  
 Glu Ala Ser Ile Gln Pro Ile Thr Arg  
 1 5

<210> 35  
 <211> 9  
 <212> PRT  
 <213> Homo sapiens

<400> 35  
 Gly Pro His Val Pro Glu Ser Ala Phe  
 1 5

<210> 36  
 <211> 10  
 <212> PRT  
 <213> Homo sapiens

<400> 36  
 Ser Leu Ala Asp Glu Ala Glu Val His Leu  
 1 5 10

<210> 37  
 <211> 9  
 <212> PRT  
 <213> Homo sapiens

<400> 37  
 Lys Ile Phe Ser Glu Val Thr Pro Lys  
 1 5

<210> 38  
 <211> 9  
 <212> PRT  
 <213> Homo sapiens

<400> 38  
 Glu Thr Val Ser Glu Glu Ser Asn Val  
 1 5

<210> 39  
 <211> 10

<212> PRT  
<213> Homo sapiens

<400> 39  
Gly Ile Val Glu Gly Leu Met Thr Thr Val  
1 5 10

<210> 40  
<211> 10  
<212> PRT  
<213> Homo sapiens

<400> 40  
Ser Leu Phe Glu Gly Ile Asp Phe Tyr Thr  
1 5 10

<210> 41  
<211> 10  
<212> PRT  
<213> Homo sapiens

<400> 41  
Phe Ile Ala Ser Lys Gly Val Lys Leu Val  
1 5 10

<210> 42  
<211> 9  
<212> PRT  
<213> Homo sapiens

<400> 42  
Cys Ile Leu Gly Glu Leu Phe Thr Lys  
1 5

<210> 43  
<211> 9  
<212> PRT  
<213> Homo sapiens

<400> 43  
Gln Thr Thr Cys Glu Val Leu Asp Tyr  
1 5

<210> 44  
<211> 9  
<212> PRT  
<213> Homo sapiens

<400> 44  
Ile Leu Asn Ala Met Ile Thr Lys Ile  
1 5

<210> 45  
<211> 9  
<212> PRT  
<213> Homo sapiens

<400> 45  
Tyr Thr Asp Phe Pro Cys Gln Tyr Val  
1 5

<210> 46  
 <211> 11  
 <212> PRT  
 <213> Homo sapiens

<400> 46  
 Ser Glu Leu Phe Arg Ser Arg Leu Asp Ser Tyr  
 1 5 10

<210> 47  
 <211> 9  
 <212> PRT  
 <213> Homo sapiens

<400> 47  
 Ala Glu Pro Ile Asn Ile Gln Thr Trp  
 1 5

<210> 48  
 <211> 10  
 <212> PRT  
 <213> Homo sapiens

<400> 48  
 Thr Leu Gly Trp Leu Leu Gln Thr Pro Lys  
 1 5 10

<210> 49  
 <211> 10  
 <212> PRT  
 <213> Homo sapiens

<400> 49  
 Gly Ser Phe Gly Asp Ile Tyr Leu Ala Ile  
 1 5 10

<210> 50  
 <211> 9  
 <212> PRT  
 <213> Homo sapiens

<400> 50  
 Ile Leu Asp Lys Val Leu Val His Pro  
 1 5

<210> 51  
 <211> 9  
 <212> PRT  
 <213> Homo sapiens

<400> 51  
 Ser Tyr Leu Asp Ser Gly Ile His Ser  
 1 5

<210> 52  
 <211> 10  
 <212> PRT  
 <213> Homo sapiens

<400> 52  
 Lys Ile Leu Asp Ala Val Val Ala Gln Glu  
 1 5 10

24 May 2019

2019203664

47608992002

<210> 53  
<211> 9  
<212> PRT  
<213> Homo sapiens

<400> 53  
Lys Glu Leu Glu Gly Ile Leu Leu Pro  
1 5

<210> 54  
<211> 9  
<212> PRT  
<213> Homo sapiens

<400> 54  
Glu Ile Asn Lys Asn Pro Lys Tyr Lys  
1 5

<210> 55  
<211> 11  
<212> PRT  
<213> Homo sapiens

<400> 55  
Phe Leu Gly Gly Asn Glu Val Gly Lys Thr Tyr  
1 5 10

<210> 56  
<211> 9  
<212> PRT  
<213> Homo sapiens

<400> 56  
Ala Gln Gln Ile Thr Gln Thr Glu Val  
1 5

<210> 57  
<211> 10  
<212> PRT  
<213> Homo sapiens

<400> 57  
Ala Arg Asp Pro His Ser Gly His Phe Val  
1 5 10

<210> 58  
<211> 11  
<212> PRT  
<213> Homo sapiens

<400> 58  
Arg Pro His Ala Ile Arg Arg Pro Leu Ala Leu  
1 5 10

<210> 59  
<211> 9  
<212> PRT  
<213> Homo sapiens

<400> 59



2019203664 24 May 2019

47608992002

Val Leu His Asp Asp Leu Leu Glu Ala  
1 5

<210> 60  
<211> 9  
<212> PRT  
<213> Homo sapiens

<400> 60  
Asp Tyr Leu Gln Tyr Val Leu Gln Ile  
1 5

<210> 61  
<211> 10  
<212> PRT  
<213> Homo sapiens

<400> 61  
Lys Glu Phe Glu Asp Asp Ile Ile Asn Trp  
1 5 10

<210> 62  
<211> 10  
<212> PRT  
<213> Homo sapiens

<400> 62  
Glu Glu Lys Arg Gly Ser Leu His Val Trp  
1 5 10

<210> 63  
<211> 11  
<212> PRT  
<213> Homo sapiens

<400> 63  
Arg Pro Arg Ala Ile Arg Arg Pro Leu Ala Leu  
1 5 10

<210> 64  
<211> 9  
<212> PRT  
<213> Homo sapiens

<400> 64  
Val Leu Arg Asp Asp Leu Leu Glu Ala  
1 5

<210> 65  
<211> 9  
<212> PRT  
<213> Homo sapiens

<400> 65  
Asp Tyr Leu Gln Cys Val Leu Gln Ile  
1 5

<210> 66  
<211> 10  
<212> PRT  
<213> Homo sapiens

<400> 66  
Lys Glu Phe Glu Asp Gly Ile Ile Asn Trp  
1 5 10

<210> 67  
<211> 10  
<212> PRT  
<213> Homo sapiens

<400> 67  
Glu Glu Lys Arg Gly Ser Leu Tyr Val Trp  
1 5 10

<210> 68  
<211> 10  
<212> PRT  
<213> Homo sapiens

<400> 68  
Glu Leu Trp Cys Arg Gln Pro Pro Tyr Arg  
1 5 10

<210> 69  
<211> 10  
<212> PRT  
<213> Homo sapiens

<400> 69  
Glu Leu Trp Cys Arg Gln Pro Pro Tyr Arg  
1 5 10

<210> 70  
<211> 10  
<212> PRT  
<213> Homo sapiens

<400> 70  
Gln Ser Tyr Cys Glu Pro Ser Ser Tyr Arg  
1 5 10

<210> 71  
<211> 10  
<212> PRT  
<213> Homo sapiens

<400> 71  
Thr Val Pro Ser Ser Ser Phe Ser His Arg  
1 5 10

<210> 72  
<211> 9  
<212> PRT  
<213> Homo sapiens

<400> 72  
Glu Val Gln Ala Ser Lys His Thr Lys  
1 5

<210> 73  
<211> 10

<212> PRT  
<213> Homo sapiens

<400> 73  
Trp Val Cys Tyr Gln Tyr Ser Gly Tyr Arg  
1 5 10

<210> 74  
<211> 9  
<212> PRT  
<213> Homo sapiens

<400> 74  
Ser Tyr Cys Glu Pro Ser Ser Tyr Arg  
1 5

<210> 75  
<211> 10  
<212> PRT  
<213> Homo sapiens

<400> 75  
Ala Thr Ile Glu Ser Val Gln Gly Ala Lys  
1 5 10

<210> 76  
<211> 9  
<212> PRT  
<213> Homo sapiens

<400> 76  
Thr Pro Thr Val Pro Ser Ser Ser Phe  
1 5

<210> 77  
<211> 9  
<212> PRT  
<213> Homo sapiens

<400> 77  
Trp Ile Met Val Leu Val Leu Pro Lys  
1 5

<210> 78  
<211> 9  
<212> PRT  
<213> Homo sapiens

<400> 78  
Glu Leu Trp Cys Arg Gln Pro Pro Tyr  
1 5

<210> 79  
<211> 10  
<212> PRT  
<213> Homo sapiens

<400> 79  
Asp Trp Ile Met Val Leu Val Leu Pro Lys  
1 5 10

<210> 80  
 <211> 10  
 <212> PRT  
 <213> Homo sapiens

<400> 80  
 Met Pro Ile Glu Pro Gly Asp Ile Gly Cys  
 1 5 10

<210> 81  
 <211> 10  
 <212> PRT  
 <213> Homo sapiens

<400> 81  
 Leu Ile Ser Ala Cys Lys Asp Gly Lys Arg  
 1 5 10

<210> 82  
 <211> 9  
 <212> PRT  
 <213> Homo sapiens

<400> 82  
 Tyr Gln Tyr Ser Gly Tyr Arg Gly Tyr  
 1 5

<210> 83  
 <211> 9  
 <212> PRT  
 <213> Homo sapiens

<400> 83  
 Leu Leu Asn Glu Val Gln Ala Ser Lys  
 1 5

<210> 84  
 <211> 10  
 <212> PRT  
 <213> Homo sapiens

<400> 84  
 Asp Trp Ile Met Val Leu Val Leu Pro Lys  
 1 5 10

<210> 85  
 <211> 9  
 <212> PRT  
 <213> Homo sapiens

<400> 85  
 Ile Ser Ala Cys Lys Asp Gly Lys Arg  
 1 5

<210> 86  
 <211> 9  
 <212> PRT  
 <213> Homo sapiens

<400> 86  
 Lys Thr Val Val Asn Lys Leu Phe Lys  
 1 5

24 May 2019

2019203664

47608992002

<210> 87  
<211> 9  
<212> PRT  
<213> Homo sapiens

<400> 87  
Asn Ser Ala Glu Asn Gly Asp Ala Lys  
1 5

<210> 88  
<211> 9  
<212> PRT  
<213> Homo sapiens

<400> 88  
Leu Trp Cys Arg Gln Pro Pro Tyr Arg  
1 5

<210> 89  
<211> 10  
<212> PRT  
<213> Homo sapiens

<400> 89  
Val Gln Lys Ile Phe His Ile Asn Pro Arg  
1 5 10

<210> 90  
<211> 10  
<212> PRT  
<213> Homo sapiens

<400> 90  
Gln Ser Tyr Cys Glu Pro Ser Ser Tyr Arg  
1 5 10

<210> 91  
<211> 9  
<212> PRT  
<213> Homo sapiens

<400> 91  
Ser Ser Ser Phe Ser His Arg Glu Lys  
1 5

<210> 92  
<211> 9  
<212> PRT  
<213> Homo sapiens

<400> 92  
Ser Tyr Cys Glu Pro Ser Ser Tyr Arg  
1 5

<210> 93  
<211> 10  
<212> PRT  
<213> Homo sapiens

<400> 93

2019203664 24 May 2019

47608992002

Thr Val Pro Ser Ser Ser Phe Ser His Arg  
1 5 10

<210> 94  
<211> 9  
<212> PRT  
<213> Homo sapiens

<400> 94  
Thr Ile Glu Ser Val Gln Gly Ala Lys  
1 5

<210> 95  
<211> 9  
<212> PRT  
<213> Homo sapiens

<400> 95  
Met Ile Trp Asn Val Gln Lys Ile Phe  
1 5

<210> 96  
<211> 9  
<212> PRT  
<213> Homo sapiens

<400> 96  
Gln Ser Tyr Cys Glu Pro Ser Ser Tyr  
1 5

<210> 97  
<211> 10  
<212> PRT  
<213> Homo sapiens

<400> 97  
Ser Ser Ile Arg Ser Phe Val Leu Gln Tyr  
1 5 10

<210> 98  
<211> 10  
<212> PRT  
<213> Homo sapiens

<400> 98  
Phe Leu Gln Glu Glu Thr Leu Thr Gln Met  
1 5 10

<210> 99  
<211> 9  
<212> PRT  
<213> Homo sapiens

<400> 99  
Val Val Met Ser Trp Ala Pro Pro Val  
1 5

<210> 100  
<211> 9  
<212> PRT  
<213> Homo sapiens

<400> 100  
Cys Ser Asp Ser Lys Leu Ile Gly Tyr  
1 5

<210> 101  
<211> 9  
<212> PRT  
<213> Homo sapiens

<400> 101  
Glu Met Leu Ile Lys Pro Lys Glu Leu  
1 5

<210> 102  
<211> 9  
<212> PRT  
<213> Homo sapiens

<400> 102  
Ile Leu Leu Met Thr Val Thr Ser Ile  
1 5

<210> 103  
<211> 9  
<212> PRT  
<213> Homo sapiens

<400> 103  
Ser Leu Met Glu His Trp Ala Leu Gly  
1 5

<210> 104  
<211> 9  
<212> PRT  
<213> Homo sapiens

<400> 104  
Leu Leu Arg Val His Thr Glu His Val  
1 5

<210> 105  
<211> 10  
<212> PRT  
<213> Homo sapiens

<400> 105  
Ser Leu Met Glu His Trp Ala Leu Gly Ala  
1 5 10

<210> 106  
<211> 9  
<212> PRT  
<213> Homo sapiens

<400> 106  
Lys Met Thr Phe Leu Phe Pro Asn Leu  
1 5

<210> 107  
<211> 9

<212> PRT  
<213> Homo sapiens

<400> 107  
Gly Leu Val Asp Glu Gln Gln Glu Val  
1 5

<210> 108  
<211> 10  
<212> PRT  
<213> Homo sapiens

<400> 108  
Ala Leu Pro Asp Pro Ile Leu Gln Ser Ile  
1 5 10

<210> 109  
<211> 9  
<212> PRT  
<213> Homo sapiens

<400> 109  
Gly Val Trp Ala Leu Pro Asp Pro Ile  
1 5

<210> 110  
<211> 10  
<212> PRT  
<213> Homo sapiens

<400> 110  
Ala Val Val Met Ser Trp Ala Pro Pro Val  
1 5 10

<210> 111  
<211> 9  
<212> PRT  
<213> Homo sapiens

<400> 111  
Thr Ser Ile Asp Arg Phe Leu Ala Val  
1 5

<210> 112  
<211> 9  
<212> PRT  
<213> Homo sapiens

<400> 112  
Gly Pro Ser Trp Gly Leu Ser Leu Met  
1 5

<210> 113  
<211> 9  
<212> PRT  
<213> Homo sapiens

<400> 113  
Leu Leu Arg Val His Thr Glu His Val  
1 5



<210> 114  
 <211> 10  
 <212> PRT  
 <213> Homo sapiens

<400> 114  
 Trp Val Asn Cys Ser Ser Met Thr Phe Leu  
 1 5 10

<210> 115  
 <211> 10  
 <212> PRT  
 <213> Homo sapiens

<400> 115  
 Val Met Ser Trp Ala Pro Pro Val Gly Leu  
 1 5 10

<210> 116  
 <211> 9  
 <212> PRT  
 <213> Homo sapiens

<400> 116  
 Ile Leu Tyr Lys Asp Asp Met Gly Val  
 1 5

<210> 117  
 <211> 9  
 <212> PRT  
 <213> Homo sapiens

<400> 117  
 Asn Ile Gln Ala Arg Ala Val Val Met  
 1 5

<210> 118  
 <211> 10  
 <212> PRT  
 <213> Homo sapiens

<400> 118  
 His Val Arg Cys Lys Ser Gly Asn Lys Phe  
 1 5 10

<210> 119  
 <211> 10  
 <212> PRT  
 <213> Homo sapiens

<400> 119  
 Leu Pro Asp Pro Ile Leu Gln Ser Ile Leu  
 1 5 10

<210> 120  
 <211> 10  
 <212> PRT  
 <213> Homo sapiens

<400> 120  
 Ser Ile Leu Leu Met Thr Val Thr Ser Ile  
 1 5 10

24 May 2019

2019203664

47608992002

<210> 121  
<211> 9  
<212> PRT  
<213> Homo sapiens

<400> 121  
Leu Met Glu His Trp Ala Leu Gly Ala  
1 5

<210> 122  
<211> 9  
<212> PRT  
<213> Homo sapiens

<400> 122  
Leu Pro Asp Pro Ile Leu Gln Ser Ile  
1 5

<210> 123  
<211> 10  
<212> PRT  
<213> Homo sapiens

<400> 123  
Val Leu Leu Arg Val His Thr Glu His Val  
1 5 10

<210> 124  
<211> 10  
<212> PRT  
<213> Homo sapiens

<400> 124  
Phe Pro Asn Leu Lys Asp Arg Asp Phe Leu  
1 5 10

<210> 125  
<211> 9  
<212> PRT  
<213> Homo sapiens

<400> 125  
Met Leu Ile Lys Pro Lys Glu Leu Val  
1 5

<210> 126  
<211> 10  
<212> PRT  
<213> Homo sapiens

<400> 126  
Ile Leu Cys Ser Leu Met Glu His Trp Ala  
1 5 10

<210> 127  
<211> 9  
<212> PRT  
<213> Homo sapiens

<400> 127

2019203664 24 May 2019

47608992002

Phe Pro Asn Leu Lys Asp Arg Asp Phe  
1 5

<210> 128  
<211> 10  
<212> PRT  
<213> Homo sapiens

<400> 128  
Ser Ile Leu Tyr Lys Asp Asp Met Gly Val  
1 5 10

<210> 129  
<211> 9  
<212> PRT  
<213> Homo sapiens

<400> 129  
Asn Thr Phe Arg His Arg Val Val Val  
1 5

<210> 130  
<211> 10  
<212> PRT  
<213> Homo sapiens

<400> 130  
Glu Val Arg Thr Ile Ser Ala Leu Ala Ile  
1 5 10

<210> 131  
<211> 10  
<212> PRT  
<213> Homo sapiens

<400> 131  
Val Pro Thr Lys Leu Ser Pro Ile Ser Ile  
1 5 10

<210> 132  
<211> 10  
<212> PRT  
<213> Homo sapiens

<400> 132  
Leu Leu Leu Gln Asp Ser Glu Cys Lys Ala  
1 5 10

<210> 133  
<211> 9  
<212> PRT  
<213> Homo sapiens

<400> 133  
Ser Gln Pro Gly Pro Ser Trp Gly Leu  
1 5

<210> 134  
<211> 10  
<212> PRT  
<213> Homo sapiens

<400> 134  
 Lys Pro Ala Val Ser Ser Asp Ser Asp Ile  
 1 5 10

<210> 135  
 <211> 9  
 <212> PRT  
 <213> Homo sapiens

<400> 135  
 Ile Thr His Thr Gly Glu Lys Pro Tyr  
 1 5

<210> 136  
 <211> 10  
 <212> PRT  
 <213> Homo sapiens

<400> 136  
 Ile Thr His Thr Gly Glu Lys Pro Tyr Lys  
 1 5 10

<210> 137  
 <211> 9  
 <212> PRT  
 <213> Homo sapiens

<400> 137  
 Lys Phe Ser Asn Ser Asn Ile Tyr Lys  
 1 5

<210> 138  
 <211> 10  
 <212> PRT  
 <213> Homo sapiens

<400> 138  
 Leu Thr Arg Gly Thr Phe Ala Asn Ile Lys  
 1 5 10

<210> 139  
 <211> 10  
 <212> PRT  
 <213> Homo sapiens

<400> 139  
 Leu Thr Asp Phe Gly Leu Ser Lys Ile Met  
 1 5 10

<210> 140  
 <211> 9  
 <212> PRT  
 <213> Homo sapiens

<400> 140  
 Leu Thr Asp Phe Gly Leu Ser Lys Ile  
 1 5

<210> 141  
 <211> 9

<212> PRT  
<213> Homo sapiens

<400> 141  
Lys Leu Thr Asp Phe Gly Leu Ser Lys  
1 5

<210> 142  
<211> 9  
<212> PRT  
<213> Homo sapiens

<400> 142  
Ser Leu Ser Leu Gly Ala His Gln Lys  
1 5

<210> 143  
<211> 10  
<212> PRT  
<213> Homo sapiens

<400> 143  
Phe Leu Lys His Lys Gln Ser Cys Ala Val  
1 5 10

<210> 144  
<211> 9  
<212> PRT  
<213> Homo sapiens

<400> 144  
Gly Val Met Thr Ser Cys Phe Leu Lys  
1 5

<210> 145  
<211> 9  
<212> PRT  
<213> Homo sapiens

<400> 145  
Phe Leu Lys His Lys Gln Ser Cys Ala  
1 5

<210> 146  
<211> 9  
<212> PRT  
<213> Homo sapiens

<400> 146  
Gly Leu Leu Cys Ala Phe Thr Leu Lys  
1 5

<210> 147  
<211> 9  
<212> PRT  
<213> Homo sapiens

<400> 147  
His Leu Cys Gly Leu Leu Cys Ala Phe  
1 5

<210> 148  
 <211> 9  
 <212> PRT  
 <213> Homo sapiens

<400> 148  
 Leu Ser Ile Phe Lys Ile Ser Ser Leu  
 1 5

<210> 149  
 <211> 10  
 <212> PRT  
 <213> Homo sapiens

<400> 149  
 Val Met Thr Ser Cys Phe Leu Lys His Lys  
 1 5 10

<210> 150  
 <211> 9  
 <212> PRT  
 <213> Homo sapiens

<400> 150  
 Met Thr Ser Cys Phe Leu Lys His Lys  
 1 5

<210> 151  
 <211> 10  
 <212> PRT  
 <213> Homo sapiens

<400> 151  
 Lys Ile Ser Ser Leu Glu Gly Arg Ser Lys  
 1 5 10

<210> 152  
 <211> 9  
 <212> PRT  
 <213> Homo sapiens

<400> 152  
 Leu Ser Ile Phe Lys Ile Ser Ser Leu  
 1 5

<210> 153  
 <211> 9  
 <212> PRT  
 <213> Homo sapiens

<400> 153  
 Arg Pro Thr Phe Tyr Arg Gln Gly Leu  
 1 5

<210> 154  
 <211> 9  
 <212> PRT  
 <213> Homo sapiens

<400> 154  
 Glu Val Ala Gly Phe Val Phe Asp Lys  
 1 5

24 May 2019

2019203664

47608992002

<210> 155  
<211> 10  
<212> PRT  
<213> Homo sapiens

<400> 155  
Glu Val Ala Gly Phe Val Phe Asp Lys Lys  
1 5 10

<210> 156  
<211> 10  
<212> PRT  
<213> Homo sapiens

<400> 156  
Phe Thr Ala Gly Gly Glu Pro Cys Leu Tyr  
1 5 10

<210> 157  
<211> 9  
<212> PRT  
<213> Homo sapiens

<400> 157  
Phe Ser Ile Val Gly Gly Tyr Gly Arg  
1 5

<210> 158  
<211> 9  
<212> PRT  
<213> Homo sapiens

<400> 158  
Tyr Met Lys Lys Ala Glu Ala Pro Leu  
1 5

<210> 159  
<211> 9  
<212> PRT  
<213> Homo sapiens

<400> 159  
Ala Pro Ile Thr Thr Thr Thr Val  
1 5

<210> 160  
<211> 10  
<212> PRT  
<213> Homo sapiens

<400> 160  
His Ser Ile Pro Leu Arg Gln Ser Val Lys  
1 5 10

<210> 161  
<211> 10  
<212> PRT  
<213> Homo sapiens

<400> 161

2019203664 24 May 2019

47608992002

Ile Ser Tyr Leu Gly Arg Asp Arg Leu Arg  
1 5 10

<210> 162  
<211> 9  
<212> PRT  
<213> Homo sapiens

<400> 162  
Ala Pro Gly Phe Asn Thr Thr Pro Ala  
1 5

<210> 163  
<211> 10  
<212> PRT  
<213> Homo sapiens

<400> 163  
Lys Ala Phe Phe Cys Asp Asp His Thr Arg  
1 5 10

<210> 164  
<211> 10  
<212> PRT  
<213> Homo sapiens

<400> 164  
Arg Pro His Gly Asp Leu Pro Ile Tyr Val  
1 5 10

<210> 165  
<211> 10  
<212> PRT  
<213> Homo sapiens

<400> 165  
Arg Leu Arg Gln Glu Val Tyr Leu Ser Leu  
1 5 10

<210> 166  
<211> 10  
<212> PRT  
<213> Homo sapiens

<400> 166  
Tyr Met Lys Lys Ala Glu Ala Pro Leu Leu  
1 5 10

<210> 167  
<211> 10  
<212> PRT  
<213> Homo sapiens

<400> 167  
Arg Leu Arg Gln Glu Val Tyr Leu Ser Leu  
1 5 10

<210> 168  
<211> 9  
<212> PRT  
<213> Homo sapiens



<400> 168  
 Cys Leu Thr Lys Arg Ser Ile Ala Phe  
 1 5

<210> 169  
 <211> 10  
 <212> PRT  
 <213> Homo sapiens

<400> 169  
 Phe Thr Ala Gly Gly Glu Pro Cys Leu Tyr  
 1 5 10

<210> 170  
 <211> 9  
 <212> PRT  
 <213> Homo sapiens

<400> 170  
 Glu Tyr Val Leu Asn Thr Thr Ala Arg  
 1 5

<210> 171  
 <211> 10  
 <212> PRT  
 <213> Homo sapiens

<400> 171  
 Asp Pro Lys Leu Gly Thr Ala Gln Pro Leu  
 1 5 10

<210> 172  
 <211> 9  
 <212> PRT  
 <213> Homo sapiens

<400> 172  
 Gln Thr His Glu Pro Glu Phe Asp Tyr  
 1 5

<210> 173  
 <211> 10  
 <212> PRT  
 <213> Homo sapiens

<400> 173  
 Ala Pro Ile Thr Thr Thr Thr Val Thr  
 1 5 10

<210> 174  
 <211> 9  
 <212> PRT  
 <213> Homo sapiens

<400> 174  
 Glu Ala Pro Leu Leu Glu Glu Gln Arg  
 1 5

<210> 175  
 <211> 10

<212> PRT  
<213> Homo sapiens

<400> 175  
Cys Leu Thr Lys Arg Ser Ile Ala Phe Leu  
1 5 10

<210> 176  
<211> 10  
<212> PRT  
<213> Homo sapiens

<400> 176  
Ala Pro Gly Phe Asn Thr Thr Pro Ala Thr  
1 5 10

<210> 177  
<211> 9  
<212> PRT  
<213> Homo sapiens

<400> 177  
Thr Thr Ala Pro Ile Thr Thr Thr Thr  
1 5

<210> 178  
<211> 9  
<212> PRT  
<213> Homo sapiens

<400> 178  
Tyr Met Lys Lys Ala Glu Ala Pro Leu  
1 5

<210> 179  
<211> 9  
<212> PRT  
<213> Homo sapiens

<400> 179  
Ile Pro Gly Phe Lys Phe Asp Asn Leu  
1 5

<210> 180  
<211> 10  
<212> PRT  
<213> Homo sapiens

<400> 180  
Glu Leu Trp Cys Arg Gln Pro Pro Tyr Arg  
1 5 10

<210> 181  
<211> 10  
<212> PRT  
<213> Homo sapiens

<400> 181  
Glu Leu Trp Cys Arg Gln Pro Pro Tyr Arg  
1 5 10

<210> 182  
 <211> 10  
 <212> PRT  
 <213> Homo sapiens

<400> 182  
 Gln Ser Tyr Cys Glu Pro Ser Ser Tyr Arg  
 1 5 10

<210> 183  
 <211> 10  
 <212> PRT  
 <213> Homo sapiens

<400> 183  
 Thr Val Pro Ser Ser Ser Phe Ser His Arg  
 1 5 10

<210> 184  
 <211> 9  
 <212> PRT  
 <213> Homo sapiens

<400> 184  
 Glu Val Gln Ala Ser Lys His Thr Lys  
 1 5

<210> 185  
 <211> 10  
 <212> PRT  
 <213> Homo sapiens

<400> 185  
 Trp Val Cys Tyr Gln Tyr Ser Gly Tyr Arg  
 1 5 10

<210> 186  
 <211> 9  
 <212> PRT  
 <213> Homo sapiens

<400> 186  
 Ser Tyr Cys Glu Pro Ser Ser Tyr Arg  
 1 5

<210> 187  
 <211> 10  
 <212> PRT  
 <213> Homo sapiens

<400> 187  
 Ala Thr Ile Glu Ser Val Gln Gly Ala Lys  
 1 5 10

<210> 188  
 <211> 9  
 <212> PRT  
 <213> Homo sapiens

<400> 188  
 Thr Pro Thr Val Pro Ser Ser Ser Phe  
 1 5

24 May 2019

2019203664

<210> 189  
 <211> 9  
 <212> PRT  
 <213> Homo sapiens

<400> 189  
 Trp Ile Met Val Leu Val Leu Pro Lys  
 1 5

<210> 190  
 <211> 9  
 <212> PRT  
 <213> Homo sapiens

<400> 190  
 Glu Leu Trp Cys Arg Gln Pro Pro Tyr  
 1 5

<210> 191  
 <211> 10  
 <212> PRT  
 <213> Homo sapiens

<400> 191  
 Asp Trp Ile Met Val Leu Val Leu Pro Lys  
 1 5 10

<210> 192  
 <211> 10  
 <212> PRT  
 <213> Homo sapiens

<400> 192  
 Met Pro Ile Glu Pro Gly Asp Ile Gly Cys  
 1 5 10

<210> 193  
 <211> 10  
 <212> PRT  
 <213> Homo sapiens

<400> 193  
 Leu Ile Ser Ala Cys Lys Asp Gly Lys Arg  
 1 5 10

<210> 194  
 <211> 9  
 <212> PRT  
 <213> Homo sapiens

<400> 194  
 Tyr Gln Tyr Ser Gly Tyr Arg Gly Tyr  
 1 5

<210> 195  
 <211> 9  
 <212> PRT  
 <213> Homo sapiens

<400> 195

2019203664 24 May 2019

47608992002

Leu Leu Asn Glu Val Gln Ala Ser Lys  
1 5

<210> 196  
<211> 10  
<212> PRT  
<213> Homo sapiens

<400> 196  
Asp Trp Ile Met Val Leu Val Leu Pro Lys  
1 5 10

<210> 197  
<211> 9  
<212> PRT  
<213> Homo sapiens

<400> 197  
Ile Ser Ala Cys Lys Asp Gly Lys Arg  
1 5

<210> 198  
<211> 9  
<212> PRT  
<213> Homo sapiens

<400> 198  
Lys Thr Val Val Asn Lys Leu Phe Lys  
1 5

<210> 199  
<211> 9  
<212> PRT  
<213> Homo sapiens

<400> 199  
Asn Ser Ala Glu Asn Gly Asp Ala Lys  
1 5

<210> 200  
<211> 9  
<212> PRT  
<213> Homo sapiens

<400> 200  
Leu Trp Cys Arg Gln Pro Pro Tyr Arg  
1 5

<210> 201  
<211> 10  
<212> PRT  
<213> Homo sapiens

<400> 201  
Val Gln Lys Ile Phe His Ile Asn Pro Arg  
1 5 10

<210> 202  
<211> 10  
<212> PRT  
<213> Homo sapiens

<400> 202  
 Gln Ser Tyr Cys Glu Pro Ser Ser Tyr Arg  
 1 5 10

<210> 203  
 <211> 9  
 <212> PRT  
 <213> Homo sapiens

<400> 203  
 Ser Ser Ser Phe Ser His Arg Glu Lys  
 1 5

<210> 204  
 <211> 9  
 <212> PRT  
 <213> Homo sapiens

<400> 204  
 Ser Tyr Cys Glu Pro Ser Ser Tyr Arg  
 1 5

<210> 205  
 <211> 10  
 <212> PRT  
 <213> Homo sapiens

<400> 205  
 Thr Val Pro Ser Ser Ser Phe Ser His Arg  
 1 5 10

<210> 206  
 <211> 9  
 <212> PRT  
 <213> Homo sapiens

<400> 206  
 Thr Ile Glu Ser Val Gln Gly Ala Lys  
 1 5

<210> 207  
 <211> 9  
 <212> PRT  
 <213> Homo sapiens

<400> 207  
 Met Ile Trp Asn Val Gln Lys Ile Phe  
 1 5

<210> 208  
 <211> 9  
 <212> PRT  
 <213> Homo sapiens

<400> 208  
 Gln Ser Tyr Cys Glu Pro Ser Ser Tyr  
 1 5

<210> 209  
 <211> 10

<212> PRT  
<213> Homo sapiens

<400> 209  
Ser Ser Ile Arg Ser Phe Val Leu Gln Tyr  
1 5 10

<210> 210  
<211> 10  
<212> PRT  
<213> Homo sapiens

<400> 210  
Glu Leu Trp Arg Arg Gln Pro Pro Tyr Arg  
1 5 10

<210> 211  
<211> 10  
<212> PRT  
<213> Homo sapiens

<400> 211  
Glu Leu Trp Arg Arg Gln Pro Pro Tyr Arg  
1 5 10

<210> 212  
<211> 10  
<212> PRT  
<213> Homo sapiens

<400> 212  
Gln Ser Tyr Cys Glu Pro Pro Ser Tyr Arg  
1 5 10

<210> 213  
<211> 10  
<212> PRT  
<213> Homo sapiens

<400> 213  
Thr Val Pro Ser Gly Ser Phe Ser His Arg  
1 5 10

<210> 214  
<211> 9  
<212> PRT  
<213> Homo sapiens

<400> 214  
Glu Val Gln Ala Ser Glu His Thr Lys  
1 5

<210> 215  
<211> 10  
<212> PRT  
<213> Homo sapiens

<400> 215  
Trp Val Cys Tyr Gln Tyr Pro Gly Tyr Arg  
1 5 10

<210> 216  
 <211> 9  
 <212> PRT  
 <213> Homo sapiens

<400> 216  
 Ser Tyr Cys Glu Pro Pro Ser Tyr Arg  
 1 5

<210> 217  
 <211> 10  
 <212> PRT  
 <213> Homo sapiens

<400> 217  
 Ala Ala Ile Glu Ser Val Gln Gly Ala Lys  
 1 5 10

<210> 218  
 <211> 9  
 <212> PRT  
 <213> Homo sapiens

<400> 218  
 Thr Pro Thr Val Pro Ser Gly Ser Phe  
 1 5

<210> 219  
 <211> 9  
 <212> PRT  
 <213> Homo sapiens

<400> 219  
 Trp Ile Met Ala Leu Val Leu Pro Lys  
 1 5

<210> 220  
 <211> 9  
 <212> PRT  
 <213> Homo sapiens

<400> 220  
 Glu Leu Trp Arg Arg Gln Pro Pro Tyr  
 1 5

<210> 221  
 <211> 10  
 <212> PRT  
 <213> Homo sapiens

<400> 221  
 Asp Trp Ile Met Ala Leu Val Leu Pro Lys  
 1 5 10

<210> 222  
 <211> 10  
 <212> PRT  
 <213> Homo sapiens

<400> 222  
 Met Pro Ile Glu Pro Gly Asp Ile Gly Tyr  
 1 5 10



24 May 2019

2019203664

47608992002

<210> 223  
<211> 10  
<212> PRT  
<213> Homo sapiens

<400> 223  
Leu Ile Ser Ala Cys Lys Asp Gly Lys Pro  
1 5 10

<210> 224  
<211> 9  
<212> PRT  
<213> Homo sapiens

<400> 224  
Tyr Gln Tyr Pro Gly Tyr Arg Gly Tyr  
1 5

<210> 225  
<211> 9  
<212> PRT  
<213> Homo sapiens

<400> 225  
Leu Leu Asn Glu Val Gln Ala Ser Glu  
1 5

<210> 226  
<211> 10  
<212> PRT  
<213> Homo sapiens

<400> 226  
Asp Trp Ile Met Ala Leu Val Leu Pro Lys  
1 5 10

<210> 227  
<211> 9  
<212> PRT  
<213> Homo sapiens

<400> 227  
Ile Ser Ala Cys Lys Asp Gly Lys Pro  
1 5

<210> 228  
<211> 9  
<212> PRT  
<213> Homo sapiens

<400> 228  
Lys Thr Val Val Asn Lys Leu Phe Glu  
1 5

<210> 229  
<211> 9  
<212> PRT  
<213> Homo sapiens

<400> 229

2019203664 24 May 2019

47608992002

Asn Pro Ala Glu Asn Gly Asp Ala Lys  
1 5

<210> 230  
<211> 9  
<212> PRT  
<213> Homo sapiens

<400> 230  
Leu Trp Arg Arg Gln Pro Pro Tyr Arg  
1 5

<210> 231  
<211> 10  
<212> PRT  
<213> Homo sapiens

<400> 231  
Ala Gln Lys Ile Phe His Ile Asn Pro Arg  
1 5 10

<210> 232  
<211> 10  
<212> PRT  
<213> Homo sapiens

<400> 232  
Gln Ser Tyr Cys Glu Pro Pro Ser Tyr Arg  
1 5 10

<210> 233  
<211> 9  
<212> PRT  
<213> Homo sapiens

<400> 233  
Ser Gly Ser Phe Ser His Arg Glu Lys  
1 5

<210> 234  
<211> 9  
<212> PRT  
<213> Homo sapiens

<400> 234  
Ser Tyr Cys Glu Pro Pro Ser Tyr Arg  
1 5

<210> 235  
<211> 10  
<212> PRT  
<213> Homo sapiens

<400> 235  
Thr Val Pro Ser Gly Ser Phe Ser His Arg  
1 5 10

<210> 236  
<211> 9  
<212> PRT  
<213> Homo sapiens

<400> 236  
Ala Ile Glu Ser Val Gln Gly Ala Lys  
1 5

<210> 237  
<211> 9  
<212> PRT  
<213> Homo sapiens

<400> 237  
Met Ile Trp Asn Ala Gln Lys Ile Phe  
1 5

<210> 238  
<211> 9  
<212> PRT  
<213> Homo sapiens

<400> 238  
Gln Ser Tyr Cys Glu Pro Pro Ser Tyr  
1 5

<210> 239  
<211> 10  
<212> PRT  
<213> Homo sapiens

<400> 239  
Ser Ser Ile Arg Gly Phe Val Leu Gln Tyr  
1 5 10

<210> 240  
<211> 10  
<212> PRT  
<213> Homo sapiens

<400> 240  
Phe Leu Gln Glu Glu Thr Leu Thr Gln Met  
1 5 10

<210> 241  
<211> 9  
<212> PRT  
<213> Homo sapiens

<400> 241  
Val Val Met Ser Trp Ala Pro Pro Val  
1 5

<210> 242  
<211> 9  
<212> PRT  
<213> Homo sapiens

<400> 242  
Cys Ser Asp Ser Lys Leu Ile Gly Tyr  
1 5

<210> 243  
<211> 9

<212> PRT  
<213> Homo sapiens

<400> 243  
Glu Met Leu Ile Lys Pro Lys Glu Leu  
1 5

<210> 244  
<211> 9  
<212> PRT  
<213> Homo sapiens

<400> 244  
Ile Leu Leu Met Thr Val Thr Ser Ile  
1 5

<210> 245  
<211> 9  
<212> PRT  
<213> Homo sapiens

<400> 245  
Ser Leu Met Glu His Trp Ala Leu Gly  
1 5

<210> 246  
<211> 9  
<212> PRT  
<213> Homo sapiens

<400> 246  
Leu Leu Arg Val His Thr Glu His Val  
1 5

<210> 247  
<211> 10  
<212> PRT  
<213> Homo sapiens

<400> 247  
Ser Leu Met Glu His Trp Ala Leu Gly Ala  
1 5 10

<210> 248  
<211> 9  
<212> PRT  
<213> Homo sapiens

<400> 248  
Lys Met Thr Phe Leu Phe Pro Asn Leu  
1 5

<210> 249  
<211> 9  
<212> PRT  
<213> Homo sapiens

<400> 249  
Gly Leu Val Asp Glu Gln Gln Glu Val  
1 5

<210> 250  
 <211> 10  
 <212> PRT  
 <213> Homo sapiens

<400> 250  
 Ala Leu Pro Asp Pro Ile Leu Gln Ser Ile  
 1 5 10

<210> 251  
 <211> 9  
 <212> PRT  
 <213> Homo sapiens

<400> 251  
 Gly Val Trp Ala Leu Pro Asp Pro Ile  
 1 5

<210> 252  
 <211> 10  
 <212> PRT  
 <213> Homo sapiens

<400> 252  
 Ala Val Val Met Ser Trp Ala Pro Pro Val  
 1 5 10

<210> 253  
 <211> 9  
 <212> PRT  
 <213> Homo sapiens

<400> 253  
 Thr Ser Ile Asp Arg Phe Leu Ala Val  
 1 5

<210> 254  
 <211> 9  
 <212> PRT  
 <213> Homo sapiens

<400> 254  
 Gly Pro Ser Trp Gly Leu Ser Leu Met  
 1 5

<210> 255  
 <211> 9  
 <212> PRT  
 <213> Homo sapiens

<400> 255  
 Leu Leu Arg Val His Thr Glu His Val  
 1 5

<210> 256  
 <211> 10  
 <212> PRT  
 <213> Homo sapiens

<400> 256  
 Trp Val Asn Cys Ser Ser Met Thr Phe Leu  
 1 5 10

24 May 2019

2019203664

47608992002

<210> 257  
<211> 10  
<212> PRT  
<213> Homo sapiens

<400> 257  
Val Met Ser Trp Ala Pro Pro Val Gly Leu  
1 5 10

<210> 258  
<211> 10  
<212> PRT  
<213> Homo sapiens

<400> 258  
Phe Leu Gln Glu Glu Arg Leu Thr Gln Met  
1 5 10

<210> 259  
<211> 9  
<212> PRT  
<213> Homo sapiens

<400> 259  
Val Val Leu Ser Trp Ala Pro Pro Val  
1 5

<210> 260  
<211> 9  
<212> PRT  
<213> Homo sapiens

<400> 260  
Cys Trp Asp Ser Lys Leu Ile Gly Tyr  
1 5

<210> 261  
<211> 9  
<212> PRT  
<213> Homo sapiens

<400> 261  
Glu Met Leu Ser Lys Pro Lys Glu Leu  
1 5

<210> 262  
<211> 9  
<212> PRT  
<213> Homo sapiens

<400> 262  
Ile Leu Leu Met Thr Val Ile Ser Ile  
1 5

<210> 263  
<211> 9  
<212> PRT  
<213> Homo sapiens

<400> 263

2019203664 24 May 2019

47608992002

Ser Leu Met Glu Pro Trp Ala Leu Gly  
1 5

<210> 264  
<211> 9  
<212> PRT  
<213> Homo sapiens

<400> 264  
Leu Leu Arg Val His Thr Glu Gln Val  
1 5

<210> 265  
<211> 10  
<212> PRT  
<213> Homo sapiens

<400> 265  
Ser Leu Met Glu Pro Trp Ala Leu Gly Ala  
1 5 10

<210> 266  
<211> 9  
<212> PRT  
<213> Homo sapiens

<400> 266  
Lys Met Thr Phe Leu Phe Ala Asn Leu  
1 5

<210> 267  
<211> 9  
<212> PRT  
<213> Homo sapiens

<400> 267  
Gly Leu Val Asp Glu Gln Gln Lys Val  
1 5

<210> 268  
<211> 10  
<212> PRT  
<213> Homo sapiens

<400> 268  
Ala Leu Pro Gly Pro Ile Leu Gln Ser Ile  
1 5 10

<210> 269  
<211> 9  
<212> PRT  
<213> Homo sapiens

<400> 269  
Gly Val Trp Ala Leu Pro Gly Pro Ile  
1 5

<210> 270  
<211> 10  
<212> PRT  
<213> Homo sapiens

47608992002

<400> 270  
Ala Val Val Leu Ser Trp Ala Pro Pro Val  
1 5 10

<210> 271  
<211> 9  
<212> PRT  
<213> Homo sapiens

<400> 271  
Ile Ser Ile Asp Arg Phe Leu Ala Val  
1 5

<210> 272  
<211> 9  
<212> PRT  
<213> Homo sapiens

<400> 272  
Gly Pro Ser Arg Gly Leu Ser Leu Met  
1 5

<210> 273  
<211> 9  
<212> PRT  
<213> Homo sapiens

<400> 273  
Leu Leu Arg Val His Thr Glu Gln Val  
1 5

<210> 274  
<211> 10  
<212> PRT  
<213> Homo sapiens

<400> 274  
Trp Val Asn Arg Ser Ser Met Thr Phe Leu  
1 5 10

<210> 275  
<211> 10  
<212> PRT  
<213> Homo sapiens

<400> 275  
Val Leu Ser Trp Ala Pro Pro Val Gly Leu  
1 5 10

<210> 276  
<211> 24  
<212> DNA  
<213> Artificial sequence

<220>  
<221> source  
<223> /note="Description of Artificial Sequence: Synthetic primer"

<400> 276  
gcacaacagt tcctgactt gcac



<210> 277  
 <211> 24  
 <212> DNA  
 <213> Artificial Sequence  
  
 <220>  
 <221> source  
 <223> /note="Description of Artificial Sequence: Synthetic primer"  
  
 <400> 277  
 tcatcaacca tgcaagcctg acct 24  
  
 <210> 278  
 <211> 24  
 <212> DNA  
 <213> Artificial Sequence  
  
 <220>  
 <221> source  
 <223> /note="Description of Artificial Sequence: Synthetic primer"  
  
 <400> 278  
 gtctctagag agaagaagga gcgc 24  
  
 <210> 279  
 <211> 24  
 <212> DNA  
 <213> Artificial Sequence  
  
 <220>  
 <221> source  
 <223> /note="Description of Artificial Sequence: Synthetic primer"  
  
 <400> 279  
 acatatgaga gtggatttgt catt 24  
  
 <210> 280  
 <211> 25  
 <212> DNA  
 <213> Artificial Sequence  
  
 <220>  
 <221> source  
 <223> /note="Description of Artificial Sequence: Synthetic primer"  
  
 <400> 280  
 atacttcagt gagacacaga gaaac 25  
  
 <210> 281  
 <211> 24  
 <212> DNA  
 <213> Artificial Sequence  
  
 <220>  
 <221> source  
 <223> /note="Description of Artificial Sequence: Synthetic primer"

47608992002

<400> 281  
ttccctaact atagctctga gctg 24

<210> 282  
<211> 20  
<212> DNA  
<213> Artificial Sequence

<220>  
<221> source  
<223> /note="Description of Artificial Sequence: Synthetic primer"

<400> 282  
aggcctgagg gatccgtctc 20

<210> 283  
<211> 22  
<212> DNA  
<213> Artificial Sequence

<220>  
<221> source  
<223> /note="Description of Artificial Sequence: Synthetic primer"

<400> 283  
cctgaatgcc ccaacagctc tc 22

<210> 284  
<211> 24  
<212> DNA  
<213> Artificial Sequence

<220>  
<221> source  
<223> /note="Description of Artificial Sequence: Synthetic primer"

<400> 284  
attacttta acaacaacgt tccg 24

<210> 285  
<211> 24  
<212> DNA  
<213> Artificial Sequence

<220>  
<221> source  
<223> /note="Description of Artificial Sequence: Synthetic primer"

<400> 285  
cctaaatctc cagacaaagc tcac 24

<210> 286  
<211> 24  
<212> DNA  
<213> Artificial Sequence

<220>  
<221> source  
<223> /note="Description of Artificial Sequence: Synthetic primer"

47608992002

primer"

<400> 286  
ccacggagtc aggggacaca gcac 24

<210> 287  
<211> 24  
<212> DNA  
<213> Artificial Sequence

<220>  
<221> source  
<223> /note="Description of Artificial Sequence: Synthetic primer"

<400> 287  
tccaacctgc aaagcttgag gact 24

<210> 288  
<211> 18  
<212> DNA  
<213> Artificial Sequence

<220>  
<221> source  
<223> /note="Description of Artificial Sequence: Synthetic primer"

<400> 288  
catgggctga ggctgatc 18

<210> 289  
<211> 18  
<212> DNA  
<213> Artificial Sequence

<220>  
<221> source  
<223> /note="Description of Artificial Sequence: Synthetic primer"

<400> 289  
caaggagaag tccccaat 18

<210> 290  
<211> 18  
<212> DNA  
<213> Artificial Sequence

<220>  
<221> source  
<223> /note="Description of Artificial Sequence: Synthetic primer"

<400> 290  
ggtgaggta caactgcc 18

<210> 291  
<211> 24  
<212> DNA  
<213> Artificial Sequence

<220>

47608992002

<221> source  
 <223> /note="Description of Artificial Sequence: Synthetic primer"  
  
 <400> 291  
 gtctctcgaa aagagaagag gaat 24  
  
 <210> 292  
 <211> 24  
 <212> DNA  
 <213> Artificial Sequence  
  
 <220>  
 <221> source  
 <223> /note="Description of Artificial Sequence: Synthetic primer"  
  
 <400> 292  
 agtgtctctc gacaggcaca ggct 24  
  
 <210> 293  
 <211> 24  
 <212> DNA  
 <213> Artificial Sequence  
  
 <220>  
 <221> source  
 <223> /note="Description of Artificial Sequence: Synthetic primer"  
  
 <400> 293  
 aaagagtcta aacaggatga gtcc 24  
  
 <210> 294  
 <211> 20  
 <212> DNA  
 <213> Artificial Sequence  
  
 <220>  
 <221> source  
 <223> /note="Description of Artificial Sequence: Synthetic primer"  
  
 <400> 294  
 ggagatatag ctgaaggta 20  
  
 <210> 295  
 <211> 24  
 <212> DNA  
 <213> Artificial Sequence  
  
 <220>  
 <221> source  
 <223> /note="Description of Artificial Sequence: Synthetic primer"  
  
 <400> 295  
 gatgagtcag gaatgccaaa ggaa 24  
  
 <210> 296  
 <211> 24  
 <212> DNA  
 <213> Artificial Sequence

47608992002

<220>  
 <221> source  
 <223> /note="Description of Artificial Sequence: Synthetic primer"  
  
 <400> 296  
 tcctctcact gtgacatcgg ccca 24  
  
 <210> 297  
 <211> 24  
 <212> DNA  
 <213> Artificial Sequence  
  
 <220>  
 <221> source  
 <223> /note="Description of Artificial Sequence: Synthetic primer"  
  
 <400> 297  
 agctctgagg tgccccagaa tctc 24  
  
 <210> 298  
 <211> 24  
 <212> DNA  
 <213> Artificial Sequence  
  
 <220>  
 <221> source  
 <223> /note="Description of Artificial Sequence: Synthetic primer"  
  
 <400> 298  
 aagtgatctt gcgctgtgtc ccca 24  
  
 <210> 299  
 <211> 22  
 <212> DNA  
 <213> Artificial Sequence  
  
 <220>  
 <221> source  
 <223> /note="Description of Artificial Sequence: Synthetic primer"  
  
 <400> 299  
 aggaccccca gttcctcatt tc 22  
  
 <210> 300  
 <211> 24  
 <212> DNA  
 <213> Artificial Sequence  
  
 <220>  
 <221> source  
 <223> /note="Description of Artificial Sequence: Synthetic primer"  
  
 <400> 300  
 cccagtttg aaagccagtg accc 24  
  
 <210> 301  
 <211> 24

24 May 2019

2019203664

47608992002

<212> DNA  
<213> Artificial Sequence  
  
<220>  
<221> source  
<223> /note="Description of Artificial Sequence: Synthetic primer"  
  
<400> 301  
tcaacagtct ccagaataag gacg 24

<210> 302  
<211> 23  
<212> DNA  
<213> Artificial Sequence  
  
<220>  
<221> source  
<223> /note="Description of Artificial Sequence: Synthetic primer"  
  
<400> 302  
gacagcggaa gtggttgagg ggt 23

<210> 303  
<211> 24  
<212> DNA  
<213> Artificial Sequence  
  
<220>  
<221> source  
<223> /note="Description of Artificial Sequence: Synthetic primer"  
  
<400> 303  
cgggctgctc cttgaggggc tgcg 24

<210> 304  
<211> 43  
<212> DNA  
<213> Artificial Sequence  
  
<220>  
<221> source  
<223> /note="Description of Artificial Sequence: Synthetic primer"  
  
<400> 304  
gacgtcggat cccacatgg gtcccgaat taagaaaaca gag 43

<210> 305  
<211> 61  
<212> DNA  
<213> Artificial Sequence  
  
<220>  
<221> source  
<223> /note="Description of Artificial Sequence: Synthetic primer"  
  
<400> 305  
cccggggcgg ccgcctaag gtgatggtga tggtagacatt ctaattcttc tccactgtaa 60

a 61

24 May 2019

2019203664

47608992002

<210> 306  
<211> 9  
<212> PRT  
<213> Homo sapiens

<400> 306  
Leu Thr Tyr Ser Gly Arg Lys Thr Ala  
1 5

<210> 307  
<211> 9  
<212> PRT  
<213> Homo sapiens

<400> 307  
Leu Thr Tyr Ser His Arg Lys Tyr Ala  
1 5

<210> 308  
<211> 10  
<212> PRT  
<213> Homo sapiens

<400> 308  
Leu Thr Tyr Ser Glu Gly Arg Lys Thr Ala  
1 5 10

<210> 309  
<211> 9  
<212> PRT  
<213> Homo sapiens

<400> 309  
Leu Thr Tyr Ser Ala Pro Asn Leu Val  
1 5

<210> 310  
<211> 15  
<212> PRT  
<213> Homo sapiens

<400> 310  
Leu Thr Tyr Ser Gly Leu Phe Ala Arg Tyr Met Ser Trp Glu Leu  
1 5 10 15

<210> 311  
<211> 11  
<212> PRT  
<213> Homo sapiens

<400> 311  
Glu Ser Val Ala Asn Gly His Pro Val Leu Thr  
1 5 10

<210> 312  
<211> 14  
<212> PRT  
<213> Homo sapiens

<400> 312

2019203664 24 May 2019

47608992002

Glu Ser Val Ala Asn Gly Phe Thr Leu Ile Ser Asn Gln Arg  
1 5 10

<210> 313  
<211> 5  
<212> PRT  
<213> Homo sapiens

<400> 313  
Asn Gly His Ser Glu  
1 5

<210> 314  
<211> 15  
<212> PRT  
<213> Homo sapiens

<400> 314  
Asn Gly His Ser Glu Ser Leu Lys His Ile Val Ala Asn Ser Glu  
1 5 10 15

<210> 315  
<211> 21  
<212> DNA  
<213> Homo sapiens

<400> 315  
cttgatcggg tcgtagctac g 21

<210> 316  
<211> 21  
<212> DNA  
<213> Homo sapiens

<400> 316  
cttgaacggg tcgtagctac g 21

<210> 317  
<211> 7  
<212> PRT  
<213> Homo sapiens

<400> 317  
Leu Asp Arg Ile Val Ala Thr  
1 5

<210> 318  
<211> 7  
<212> PRT  
<213> Homo sapiens

<400> 318  
Leu Glu Arg Ile Val Ala Thr  
1 5

<210> 319  
<211> 14  
<212> PRT  
<213> Homo sapiens

<400> 319



2019203664 24 May 2019

47608992002

Leu Tyr Ser Gly Leu Phe Ala Arg Tyr Met Ser Trp Glu Leu  
1 5 10

<210> 320  
<211> 13  
<212> PRT  
<213> Homo sapiens

<400> 320  
Glu Ser Val Ala Asn Gly Phe Thr Leu Ser Asn Gln Arg  
1 5 10

<210> 321  
<211> 10  
<212> PRT  
<213> Homo sapiens

<400> 321  
Met Pro Ile Glu Pro Gly Asp Ile Gly Tyr  
1 5 10

<210> 322  
<211> 10  
<212> PRT  
<213> Homo sapiens

<400> 322  
Met Pro Ile Glu Pro Gly Asp Ile Gly Cys  
1 5 10

<210> 323  
<211> 9  
<212> PRT  
<213> Homo sapiens

<400> 323  
Thr Pro Thr Val Pro Ser Gly Ser Phe  
1 5

<210> 324  
<211> 9  
<212> PRT  
<213> Homo sapiens

<400> 324  
Thr Pro Thr Val Pro Ser Ser Ser Phe  
1 5

<210> 325  
<211> 9  
<212> PRT  
<213> Homo sapiens

<400> 325  
Val Val Leu Ser Trp Ala Pro Pro Val  
1 5

<210> 326  
<211> 78  
<212> PRT  
<213> Homo sapiens

47608992002

<400> 326  
 Gly Pro Gly Ile Lys Lys Thr Glu Arg Arg Ala Arg Ser Ser Pro Lys  
 1 5 10 15

Ser Asn Asp Ser Asp Leu Gln Glu Tyr Glu Leu Glu Val Lys Arg Val  
 20 25 30

Gln Asp Ile Leu Ser Gly Ile Glu Lys Pro Gln Val Ser Asn Ile Gln  
 35 40 45

Ala Arg Ala Val Val Leu Ser Trp Ala Pro Pro Val Gly Leu Ser Cys  
 50 55 60

Gly Pro His Ser Gly Leu Ser Phe Pro Tyr Ser Tyr Glu Val  
 65 70 75

<210> 327  
 <211> 78  
 <212> PRT  
 <213> Mus musculus

<400> 327  
 Gly Pro Gly Ile Lys Lys Thr Glu Arg Arg Ala Arg Ser Ser Pro Lys  
 1 5 10 15

Ser Ser Asp Ser Asp Leu Gln Glu Tyr Glu Leu Glu Val Lys Arg Val  
 20 25 30

Gln Asp Ile Leu Ser Gly Ile Glu Lys Pro Gln Val Ser Asn Ile Gln  
 35 40 45

Ala Arg Ala Val Val Leu Ser Trp Ala Pro Pro Val Gly Leu Ser Cys  
 50 55 60

Gly Pro His Gly Gly Leu Ser Phe Pro Tyr Ser Tyr Glu Val  
 65 70 75

<210> 328  
 <211> 80  
 <212> PRT  
 <213> Gallus gallus

<400> 328  
 Ala Pro Gly Val Lys Lys Pro Glu Arg Arg Ala Arg Ser Ser Pro Lys  
 1 5 10 15

Ser Thr Glu Gln Glu Pro His Glu Tyr Asp Ser Glu Thr Lys Arg Val  
 20 25 30

Gln Asp Ile Leu Ser Gly Met Glu Lys Pro Gln Val Thr Asn Ile Gln  
 35 40 45

Ala Arg Thr Val Leu Leu Ser Trp Ser Pro Pro Ala Gly Leu Leu Asn  
 50 55 60

47608992002

Thr Asp Arg His Asn Asn Gly Leu Pro Tyr Ala Cys Thr Tyr Glu Val  
65 70 75 80

<210> 329  
<211> 76  
<212> PRT  
<213> Danio rerio

<400> 329  
Lys Lys Pro Thr Arg Gly Ala Arg Ser Ser Pro Arg Ser Ser Glu Pro  
1 5 10 15

Glu Leu Gln Asp His Asp Ser Glu Ala Lys Arg Val Gln Asp Val Leu  
20 25 30

Ser Gly Met Glu Lys Pro Gln Val Leu Asn Ile Gln Ser Arg Thr Ala  
35 40 45

Arg Leu Thr Trp Ala Pro Pro Ala Gly Leu Gln Asn Arg Glu Arg His  
50 55 60

Ser Asn Gly His Pro Phe Thr Cys Ser Tyr Glu Val  
65 70 75

<210> 330  
<211> 78  
<212> PRT  
<213> Homo sapiens

<400> 330  
Ile Pro Gly Leu Thr Asp Gln Lys Thr Val Pro Thr Pro Thr Val Pro  
1 5 10 15

Ser Gly Ser Phe Ser His Arg Glu Lys Pro Ser Ile Phe Tyr Gln Gln  
20 25 30

Glu Trp Pro Asp Ser Tyr Ala Thr Glu Lys Ala Leu Lys Val Ser Thr  
35 40 45

Gly Pro Gly Pro Ala Asp Gln Lys Thr Glu Ile Pro Ala Val Gln Ser  
50 55 60

Ser Ser Tyr Pro Gln Arg Glu Lys Pro Ser Val Leu Tyr Pro  
65 70 75

<210> 331  
<211> 77  
<212> PRT  
<213> Mus musculus

<400> 331  
Ser Glu Trp Leu Ala Arg Pro Ser Glu Val Ser Glu Ala Leu Ile Gln  
1 5 10 15

47608992002

Ala Thr Ser Glu Thr Ser Ser Asp Leu Ala Asn Ser Cys Phe Ser Ile  
 20 25 30

Ser Gln His Pro Leu Thr Glu Gly Leu Gln Gly Lys Ala Glu Ser Gly  
 35 40 45

Val Leu Thr Arg Cys Gly Asp Ala Lys Tyr Ser Ser Leu Tyr Glu Asn  
 50 55 60

Leu Gly Ala Gln Ser Glu Arg Ile Ala Val Leu Gln Arg  
 65 70 75

<210> 332  
 <211> 76  
 <212> PRT  
 <213> Gallus gallus

<400> 332  
 Glu Ile Lys Ala Glu Leu Leu Leu Ser Ala Lys Lys Ser Gly Gln Ala  
 1 5 10 15

Lys Gly Thr Arg Ser Tyr Ser Ser Leu Ala Ala Ser Val Tyr Ser Cys  
 20 25 30

Asn Gln Glu Ala Asp Glu Glu His Ser Lys Ala Ser Ser Asp Lys Arg  
 35 40 45

Phe His Ser Asp Ser Gln Thr Gln Ala Phe Arg Thr Lys Glu Leu Leu  
 50 55 60

Glu Pro Ser Leu Gln His Val Val Pro Leu Tyr Arg  
 65 70 75

<210> 333  
 <211> 78  
 <212> PRT  
 <213> Homo sapiens

<400> 333  
 Leu Pro Phe Pro Lys Asp Ala Ser Leu Asn Lys Cys Ser Phe Leu His  
 1 5 10 15

Pro Glu Pro Val Val Gly Ser Lys Met His Lys Met Pro Asp Leu Phe  
 20 25 30

Ile Ile Gly Ser Gly Glu Ala Met Leu Gln Leu Ile Pro Pro Phe Gln  
 35 40 45

Cys Arg Arg His Cys Gln Ser Val Ala Met Pro Ile Glu Pro Gly Asp  
 50 55 60

Ile Gly Tyr Val Asp Thr Thr His Trp Lys Val Tyr Val Ile  
 65 70 75

47608992002

<210> 334  
 <211> 78  
 <212> PRT  
 <213> Mus musculus

<400> 334  
 Leu Pro Phe Pro Lys Asp Ser Ser Leu Asn Lys Cys Phe Leu Ile Gln  
 1 5 10 15  
 Pro Glu Pro Val Val Gly Ser Lys Met His Lys Val His Asp Leu Phe  
 20 25 30  
 Thr Leu Gly Ser Gly Glu Ala Met Leu Gln Leu Ile Pro Pro Phe Gln  
 35 40 45  
 Cys Arg Thr His Cys Gln Ser Val Ala Met Pro Ile Glu Ser Gly Asp  
 50 55 60  
 Ile Gly Tyr Ala Asp Ala Ala His Trp Lys Val Tyr Ile Val  
 65 70 75

<210> 335  
 <211> 77  
 <212> PRT  
 <213> Gallus gallus

<400> 335  
 Leu Ser Phe Pro Lys Thr Val Ser Leu Glu Asn Cys Phe Leu Ile Arg  
 1 5 10 15  
 His Pro Asp Leu Gly Asn Lys Ser Tyr Ser Leu His Ser Leu Phe Val  
 20 25 30  
 Val Gly Ser Gly His Leu Thr Leu Thr Val Ala Pro Leu Asp Lys Cys  
 35 40 45  
 Arg Gly His Cys Glu Met Phe Lys Val Asp Leu Glu Ala Gly Asp Leu  
 50 55 60  
 Gly Tyr Ala Ser Met Asp Tyr Trp Met Met Ser Phe Val  
 65 70 75

<210> 336  
 <211> 78  
 <212> PRT  
 <213> Danio rerio

<400> 336  
 Cys Pro Leu Leu Glu Ile Trp Ser Ser Thr Leu Gln Arg Cys Arg Leu  
 1 5 10 15  
 Ser Ser Arg Arg Pro Gln Pro Ser Arg Val Gln Val Leu Gly Trp Met  
 20 25 30  
 Val Val Ala Asp Gly Ser Pro Asp Val Arg Leu Leu Pro Val Gln Arg  
 35 40 45

47608992002

Cys Arg Lys His Cys Arg Ser Phe Ser Leu Arg Leu Glu Pro Gly Asp  
 50 55 60

Met Val Phe Ala Asp Ser Gln Ile Trp Leu Met Glu Leu Ser  
 65 70 75

<210> 337  
 <211> 9  
 <212> PRT  
 <213> Homo sapiens

<400> 337  
 Val Val Met Ser Trp Ala Pro Pro Val  
 1 5

<210> 338  
 <211> 114  
 <212> DNA  
 <213> Artificial Sequence

<220>  
 <221> source  
 <223> /note="Description of Artificial Sequence: Synthetic polynucleotide"

<400> 338  
 caaggcttga cgactcggcc gtgtatctct gtgccagcag cttagttttc gggacagggt 60  
 tcgtttcggg ctacgagcag tacttcgggc cgggcaccag gctcacggtc acag 114