

No. 780,815.

PATENTED JAN. 24, 1905.

W. A. ROBERSON.
CONVERTIBLE COT.

APPLICATION FILED FEB. 29, 1904.

2 SHEETS—SHEET 1.

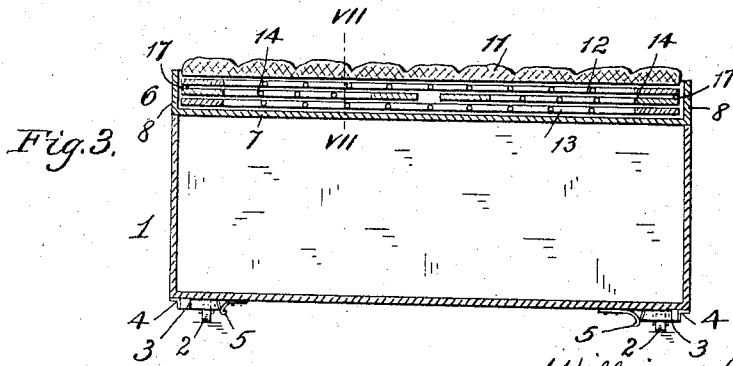
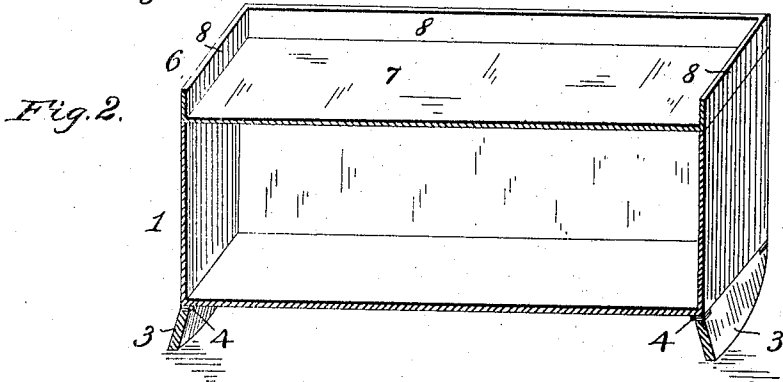
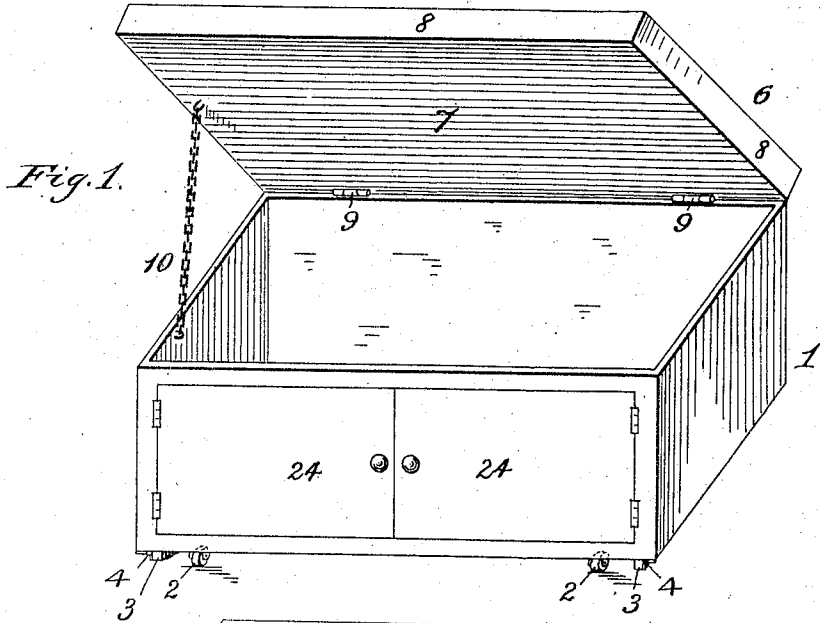

Inventor

William A. Roberson

Witnesses

S. H. McClelland

J. S. Barker

334

N. N. Low

Attorney

W. A. ROBERSON.
CONVERTIBLE COT.
APPLICATION FILED FEB. 29, 1904.

2 SHEETS—SHEET 1.

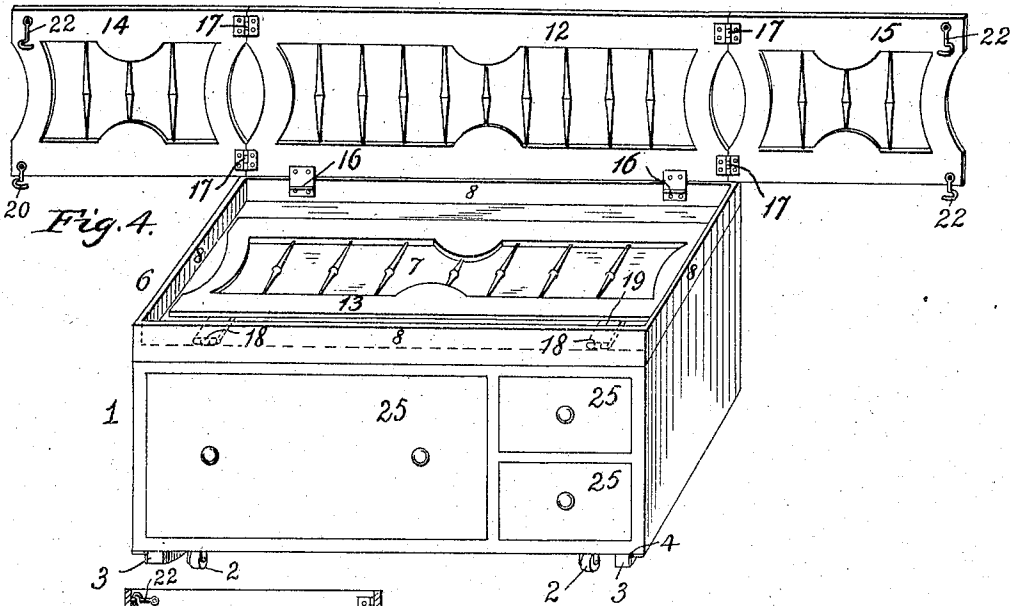

Fig. 4.

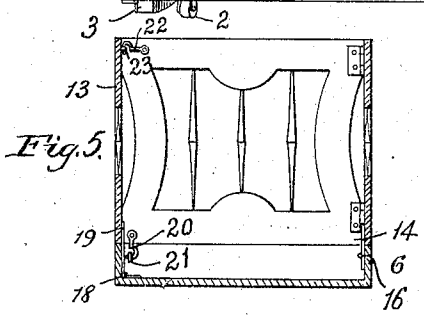

Fig. 5.

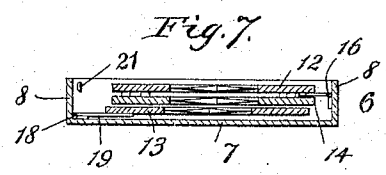

Fig. 7.

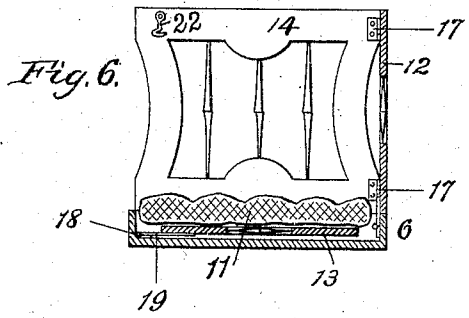

Fig. 6.

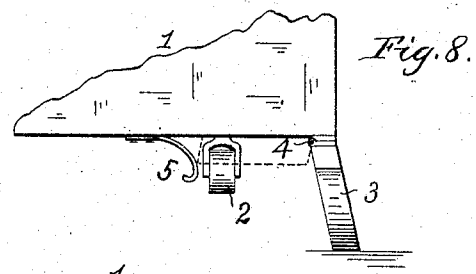

Fig. 8.

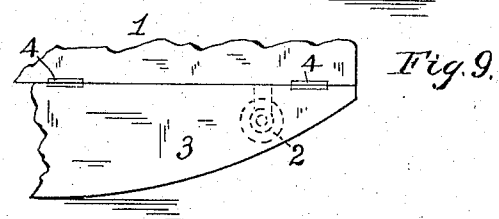

Fig. 9.

Witnesses
S. H. McCalland
J. S. Baskett

Inventor
William A. Roberson
 By
H. N. Low
 Attorney

UNITED STATES PATENT OFFICE.

WILLIAM A. ROBERSON, OF LOUISVILLE, KENTUCKY.

CONVERTIBLE COT.

SPECIFICATION forming part of Letters Patent No. 780,815, dated January 24, 1905.

Application filed February 29, 1904. Serial No. 195,867.

To all whom it may concern:

Be it known that I, WILLIAM A. ROBERSON, a citizen of the United States, residing at Louisville, in the county of Jefferson and State of Kentucky, have invented certain new and useful Improvements in Convertible Cots, of which the following is a specification.

My invention relates to furniture of that class which is convertible from one use to another, and more particularly to a receptacle for infants' clothes and other articles which is convertible into an infant's cot or cradle or into a sofa or window-seat.

The invention consists in the parts and combinations thereof hereinafter set forth and claimed.

In order to make the invention more clearly understood, I have shown in the accompanying drawings means for carrying the same into practical effect without limiting my improvements in their useful applications to the particular construction which for the sake of illustration I have delineated.

In said drawings, Figure 1 is a perspective view of the cot with the top raised to give access to the interior of the receptacle. Fig. 2 is a perspective sectional view of the same with the top closed and the contents of the top removed. Fig. 3 is a vertical longitudinal sectional view of the same with the railings closed in and the device adapted as a seat. Fig. 4 is a perspective view with the mattress removed and the railings exposed and partly unfolded to illustrate their construction. Fig. 5 is a transverse vertical section of the top with all of the railings unfolded. Fig. 6 is a similar view with the side and back rails unfolded and the front rail folded. Fig. 7 is a similar view on line VII, Fig. 3, with all of the rails folded. Figs. 8 and 9 are respectively side and end views of a portion of the bottom of the receptacle illustrating the arrangement of the casters and rockers.

Referring to the drawings, 1 is the main body of the device, constituting a receptacle for clothing or other articles. This is carried on four casters 2 and is further provided at each end with a rocker 3, hinged at 4 to the bottom of the receptacle. Such rockers are

are folded up against the bottom, Figs. 1 and 3, and held by a fastening 5, they will be entirely above the bottoms of the casters and out of contact with the floor, so that the cot may be rolled about freely on the casters. When the rockers are turned down, Figs. 2, 8, and 9; they will project below the casters and allow the cot to be rocked as a cradle without the casters touching the floor. The top 6 of the receptacle is in the form of a shallow tray, having a bottom 7 and edges 8, which is hinged at 9 to the rear edge of the receptacle 1. 10 is a chain which allows the top to be turned up sufficiently, Fig. 1, to give access to the interior of the receptacle, but not so high as to disarrange the contents of the top.

11 is a removable mattress or cushion fitted within the edges 8 of the top, which is used as a seat, Fig. 3, under certain conditions, or otherwise serves with suitable bedclothing (not shown) as an infant's bed.

With the top 6 are combined a rear railing 12, front railing 13, and end railings 14 and 15, which are hinged to the top and to each other to fold in a peculiar manner within the top and beneath the cushion 11.

16 indicates hinges by which the rear railing 12 is attached to the rear sides of the top, so that it may fold forward into the top, as seen in Fig. 3, in which position it forms the immediate support of the cushion.

17 17 are hinges uniting the rear edges of the end railings 14 15 with the ends of the rear railing 12 in such manner that said end railings may fold against the front of the rear railing before the latter is turned down into the top. In the latter position they support the rear railing. The front railing 13 is when folded into the top and resting on the bottom 7 the support of the end railings and is hinged to the front of the top by hinges 18. The axis of the hinges 18 is below that of the hinges 16 near the bottom of the tray and the hinges 18 are connected with the front railing by vertical bars 19, which extend up above the top of the edge 8, Fig. 5. All the railings are arranged to rest on the edge 8 when they are unfolded and in vertical position.

20 indicates hooks on the lower part of the end railings and adapted to engage eyes 21 on the top 6 to hold the rear and end rails in unfolded position. 22 indicates hooks on the top parts of the end rails arranged to engage eyes 23 on the front rail, whereby all of the railings mutually support each other. Other suitable fastenings may be used for this purpose.

10 Instead of hinging the top 6 to afford access to the interior of the receptacle the top may be fitted loosely onto the part 1, so as to be vertically removable in the manner of a tray, or said top may be rigidly attached and the
15 receptacle 1 fitted with sliding drawers arranged to be pulled out at the front.

The device may be used as a seat with all of the railings folded within the top, or as a seat with back and side arms, the back and
20 end railings being elevated and secured in position and the front railing folded within the top, Fig. 6, or as a crib with all four railings elevated. In the latter case the rockers may be turned down to convert the device
25 into a cradle, and in either of the first-mentioned arrangements it may be used as a rocking seat or chair. It may be used with especial convenience as an infant's cot at night arranged close at the side of the mother's bed
30 with the front railing turned down within the top and the rear and end railings elevated. It will be understood that in the manipulations of the railings the cushion or mattress is removed and returned to position after the
35 adjustments are completed. The parts are or may be so arranged and proportioned that either the front railing alone when folded or the back railing when folded presents a level support for the mattress.

40 The construction and operation of the rocker-holding device 5 is best seen in Figs. 3 and 8, in which it is shown as a cam-spring attached to the bottom of the receptacle 1 and arranged to engage frictionally with the bottom edge
45 of the rocker when the latter is folded up. The other improved features of my invention are not, however, limited to the employment of this particular form of fastening. The rockers 3 are shaped and hinged in such manner that when they are unfolded in operative
50 position they have outward inclinations, so that the weight of the cot will keep them in such position until they are intentionally folded up, Figs. 2 and 8. As above stated, the
55 top of the receptacle 1 need not be hinged, and access to its interior may be had by other means. In Fig. 1 are shown two hinged doors 24 24 for this purpose, which may be employed in connection with a hinged top or
60 with a fixed top, or the receptacle may be fitted with sliding drawers of convenient arrangement. In Fig. 4 three drawers 25 of this character are indicated.

The exterior of the receptacle 1 may be

covered with cloth or leather or upholstered 65 in any preferred manner.

What I claim, and desire to secure by Letters Patent, is—

1. A cot provided with folding railings at the rear, front and ends, the end railings being hinged to the ends of the rear railing, and all foldable on the top of the cot, the said rear railing being so foldable after the end railings have been folded against the same, the cot having upstanding flanges within which said
70 railings fold to points below the tops of the flanges so as to receive a mattress within said flanges, substantially as set forth.

2. The combination of the cot having the upstanding edges 8, the four railings hinged
80 to fold within said edges to a level below the top of said edges or to be elevated and secured above the same, and the removable mattress fitting within said edges, substantially as set forth.

3. The combination of the receptacle provided with a hinged top, a removable mattress fitting said top, and four folding railings connected with said top and acting as a guard
90 around or as a support for said mattress, substantially as set forth.

4. The combination of a cot, a front railing hinged thereto, a rear railing hinged thereto, said front and rear railings being so hinged at points within and below the top edges of
95 the cot-frame, end railings hinged to the ends of said rear railing, a bottom 7 arranged to support the railings on a level when they are folded within said top edges, securing means for uniting lower parts of the end railings to the
100 cot, and securing means for uniting the upper parts of the end railings with the front railing, substantially as set forth.

5. The combination of a cot having upstanding edges 8, and four railings hinged to the
105 cot and adjustable vertically above said edges or foldable within the same, to a level below the top of said edges, the end railings being hinged to the ends of the rear railing, securing means for uniting the end railings with
110 said edges, and securing means for uniting the end railings with the ends of the front railing, substantially as set forth.

6. The combination of the receptacle having a hinged top, edges 8 around the latter,
115 the rear railing hinged to said top, end railings hinged to the ends of the rear railing, the front railing hinged to said top, and means whereby said railings are secured in elevated positions, said railings being foldable, one over
120 another, within said edges, substantially as set forth.

In testimony whereof I affix my signature in presence of two witnesses.

WILLIAM A. ROBERSON.

Witnesses:

M. A. CURLEY,
JOHN C. DOOLAN.