

- [54] **LIGHT DIMMING SYSTEM HAVING MULTIPLE CONTROL UNITS**
- [72] Inventor: **James C. Johnson**, Arlington, Tex.
- [73] Assignee: **Hunt Electronics Company**, Dallas, Tex.
- [22] Filed: **July 30, 1971**
- [21] Appl. No.: **167,712**
- [52] U.S. Cl. **317/148.5 B**, 307/112, 307/115, 315/194, 317/157, 340/147 R
- [51] Int. Cl. **H01h 47/32**
- [58] Field of Search... 317/136, 146, 148.5, 149, 154, 317/157; 323/24; 340/147 R, 150; 315/194, 199, 200, 208, DIG. 4; 307/112, 113, 114, 139, 140, 157

3,609,515	9/1971	Babcock et al.	323/24 X
3,518,486	6/1970	Babcock	315/199 X
2,892,132	6/1959	Mallory	317/154 X

Primary Examiner—J. D. Miller
Assistant Examiner—Harry E. Moose, Jr
Attorney—Giles C. Clegg, Jr. et al.

[57] **ABSTRACT**

A plurality of separate remote control units are provided for individually and independently controlling the operation of a common lamp dimmer unit. Each remote control unit is capable of turning on and off the lamp dimmer unit and of controlling the brightness of the lamp or lamps independently of the previous setting or condition of any of the other remote control units. The various remote control units are connected in parallel with one another and with the remainder of the system by a three-wire conductor system.

[56] **References Cited**

UNITED STATES PATENTS

- 3,629,608 12/1971 Trindle 317/154 X

12 Claims, 2 Drawing Figures

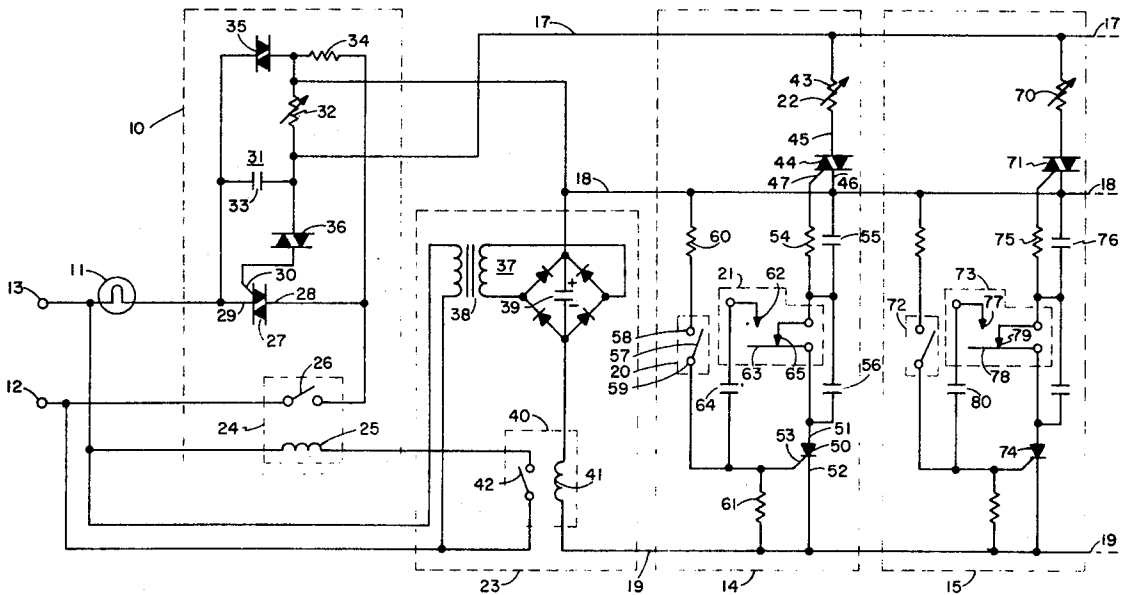

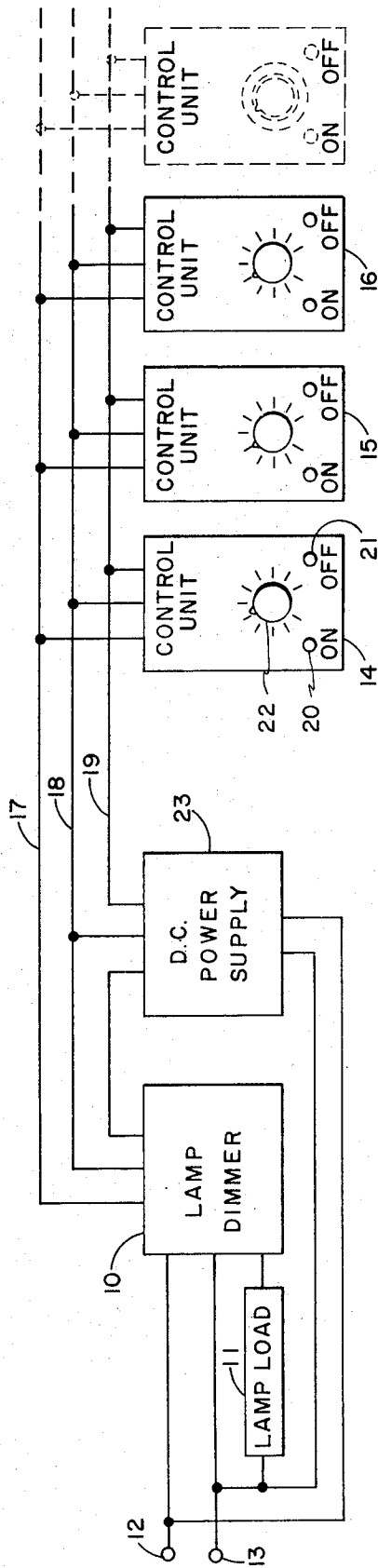

FIG. 1

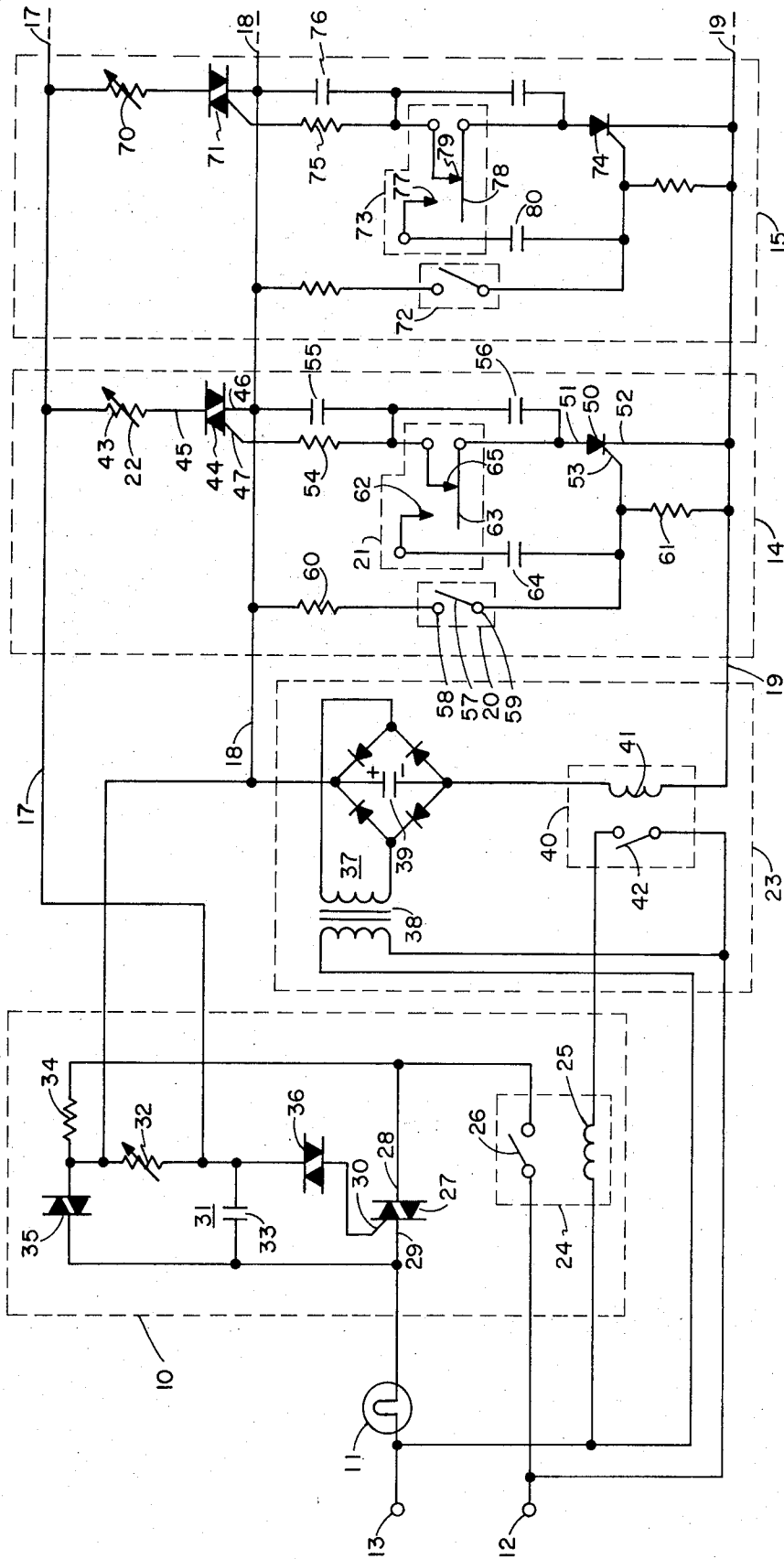

FIG. 2

LIGHT DIMMING SYSTEM HAVING MULTIPLE CONTROL UNITS

BACKGROUND OF THE INVENTION

This invention relates to light dimming systems and to control units for such systems.

One of the problems associated with lighting systems is that of the convenient location of the switch unit or control unit for turning the lights on and off. Large areas may dictate the use of more than one such control unit. Conventional wiring methods would then necessitate the use of a "three-way" or "four-way" switching scheme. Even when only two or three control units are desired, the wiring methods become quite complicated. Matters are further complicated when it is desired that each control unit also provide a light dimming function.

It has been heretofore proposed to provide a light dimming system employing multiple remote switch units or control units for turning the lights on and off and controlling the brightness thereof. In the proposed system, each remote unit employs a three-position switch and the switches in the various remote units are connected in parallel to a reversible motor which drives the dimming mechanism in a master dimmer unit. By operating the switch in any given remote unit, the motor is activated to raise or lower the lamp brightness. When the mechanism controlled by the motor reaches the end of its travel in the minimum brightness direction, a switch is actuated to turn off the master dimmer unit and, hence, the lamps connected thereto. This proposed system results in a smooth dimming action having a fixed rate of change from one control setting to another. As many remote control units as are necessary may be utilized. Unfortunately, however, this previously proposed system does require the use of a motorized control and dictates a fixed rate of change when going from one brightness level to another. Thus, where a relatively large change is desired, the time to accomplish same may become rather noticeable. Also, in order to turn off the lights, it is necessary to sit and wait for the motor to turn the control mechanism back to the zero position.

It is an object of the invention, therefore, to provide wherein new and switching device light dimming system semiconductor multiple remote control units wherein each device i) control unit can instantaneously determine the lighting condition independently of any previous setting or condition established by any of the other remote control units.

It is another object of the invention to provide a new and improved light dimming system employing multiple remote control units and which does not require the use of a motor.

It is a further object of the invention to provide a new and improved remote control unit for a light dimming system which is adapted to be connected in parallel with any desired number of additional such control units by a relatively simple three-wire type conductor system.

For a better understanding of the present invention, together with other and further objects and features thereof, reference is had to the following description taken in connection with the accompanying drawings, the scope of the invention being pointed out in the appended claims.

BRIEF DESCRIPTION OF THE DRAWINGS

Referring to the drawings:

FIG. 1 is a block diagram of a light dimming system constructed in accordance with the present invention; and

FIG. 2 is a detailed schematic circuit design of the FIG. 1 system.

DESCRIPTION OF THE ILLUSTRATED EMBODIMENT

Referring to FIG. 1, there is shown a master lamp dimmer unit 10 for controlling the brightness level of a lamp or lamps contained in a lamp load 11. The lamps in lamp load 11 may be of either the incandescent or fluorescent type. In use, alternating-current power is applied between power line terminals 12 and 13 and the lamp dimmer 10 functions to control the root-mean-square (r.m.s.) value of the current flow through the lamp load 11. A plurality of separate remote control units 14, 15 and 16 are coupled in parallel with one another and to the remainder of the system including the dimmer unit 10 by a conductor system or wiring system having only three wires 17, 18 and 19. There is no practical limit to the number of control units which can be connected to the wires 17, 18 and 19, three being shown by way of example only. Each of the control units is of identical construction and considering for example the control unit 14 such control unit 14 includes a spring loaded pushbutton switch 20 for turning on the lamp dimmer unit 10, a spring loaded pushbutton switch 21 for turning off the dimmer unit 10 and a rotatable control knob 22 for setting the brightness or intensity level for the lamp load 11 when the dimmer 10 is turned on. Each of the control units is constructed so that, by proper manipulation of the pushbuttons and control knob at any one of the control stations, the human operator may turn the lamp load 11 on or off and may set the brightness level for such lamp load 11 from that control unit independently of and regardless of previous settings at any of the other control units. A direct-current power supply 23 provides direct-current operating voltage for energizing individual control circuits contained in the different control units 14, 15 and 16.

Referring to FIG. 2, there is shown a schematic circuit diagram for the light dimming system of FIG. 1 with the exception that, for simplicity of illustration, only the first two control units 14 and 15 are shown in FIG. 2. As seen in FIG. 2, the dimmer unit 10 includes a relay 24 having a coil winding 25 for controlling a normally-open relay switch 26. Dimmer 10 further includes a control mechanism for determining the root-mean-square value of the current flow through the lamp load 11 when the switch 26 is closed. For sake of an example, lamp load 11 is assumed to be of the incandescent type. This control mechanism includes a bilateral semiconductor triode switching device 27 having an anode 28, a cathode 29 and a gate electrode 30. Gate electrode 30 is controlled by a resistor-capacitor timing circuit 31 which determines the fraction of each half cycle of the alternating current during which the switching device 27 is rendered conductive. Timing circuit 31 includes an adjustable resistor 32 and a capacitor 33. Alternating-current voltage is supplied to such timing circuit 31 by means of a resistor 34 and a bi-

lateral semiconductor diode device 35, these elements 34 and 35 serving to regulate the amplitude of the alternating-current voltage applied to the timing circuit 31. Capacitor 33 is coupled to the gate electrode 30 by way of a second bilateral semiconductor diode device 36.

At the beginning of each half cycle of the alternating-current line voltage, the capacitor 33 is charged by way of the resistor 32, the rate of charging being determined by the resistor-capacitor time constant provided by resistor 32 and capacitor 33. When the charge on capacitor 33 reaches the breakover level of the bilateral diode device 36, such device 36 suddenly becomes conductive and suddenly dumps the charge on capacitor 33 into the gate electrode 30 to render the triode switching device 27 conductive. Device 27 remains conductive until the alternating-current line voltage reverses polarity, at which point it is turned off. Following such turn off, the charging and triggering sequence is repeated for the next half cycle. The resistance value of resistor 32 determines the charging rate and, hence, the point during each half cycle at which the triode switching device 27 is turned on. The resistance value of resistor 32 is set to provide the lower limit or minimum brightness level desired for the lamp load 11. This maximum resistance setting is not normally changed during the subsequent usage of the system with a particular lamp load.

A somewhat modified form of dimmer unit would be required for the case of a fluorescent type lamp load, the principle difference being that a control element for the fluorescent lamp and not the fluorescent lamp itself would be connected in series with the triode switching device 27. The remote control units 14, 15, etc. and the power supply unit 23 would, however, remain the same as hereinafter described.

The direct-current power supply circuit 23, which is common to the various control units 14, 15, etc. includes a bridge-type rectifier circuit 37 which is coupled to the alternating-current power line by a transformer 38. The resulting direct-current voltage developed across a filter or smoothing capacitor 39 is applied between the control unit connector wires 18 and 19. The power supply circuit 23 further includes a relay 40 having a coil winding 41 and switch contact means represented by a switch 42. Switch 42 is normally open and is closed by the flow of current through the coil winding 41. Closure of this relay switch 42 energizes the coil winding 25 in the dimmer relay 24 which, in turn, closes the dimmer relay switch 26 which, in turn, turns on the dimmer unit 10 and energizes the lamp load 11. As will be seen, the coil winding 41 also constitutes a current limiting means for limiting the power supply current flow to the control units 14, 15, etc.

The first remote control unit 14 for controlling the operation of the dimmer unit 10 includes an adjustable control mechanism and switch circuit means connected in series therewith. The adjustable control mechanism is represented by an adjustable impedance means represented by an adjustable resistor 43 having a first end connected to the connector means represented by the remote unit connector wire 17. The switch circuit means is represented by a switching device 44 having a pair of power electrodes 45 and 46 and a control electrode 47. In the illustrated embodiment, the switching

device 44 takes the form of a bilateral semiconductor triode switching device and, for simplicity of explanation, the electrode 45 will be referred to as the anode, the electrode 46 as the cathode and the electrode 47 as the gate electrode. The anode 45 is connected to the second end of the adjustable resistor 43 and the cathode 46 is connected to the connector means represented by the second remote unit connector wire 18. Thus, connector wires 17 and 18 serve to connect the series combination of the adjustable resistor 43 and the switching device 44 in parallel with the timing circuit resistor 32 in the dimmer unit control mechanism. The adjustable element of resistor 43 is mechanically coupled to the control knob 22 located on the front panel of the control unit 14.

The control unit 14 further includes control circuit means for activating and disabling the switch circuit means represented by switching device 44. This control circuit means includes a second switching device 50 having a pair of power electrodes 51 and 52 and a control electrode 53. In the illustrated embodiment, the switching device 50 takes the form of a unilateral semiconductor triode switch of the type known as a silicon-controlled rectifier. For sake of explanation, the electrode 51 of switching device 50 will be referred to as the anode, the electrode 52 as the cathode and the electrode 53 as the gate electrode. The anode 51 is coupled to the gate electrode 47 of the first switching device 44 by way of the "off" switch 21 and a resistor 54. The cathode 52 is connected to the connector means represented by remote unit connector wire 19. A "commutating" capacitor 55 is coupled between the second connector wire 18 and the anode 51 of device 50 by way of the "off" switch 21. A further capacitor 56 is connected across the "off" switch 21 for improving the switching action in the switch 21.

The control circuit portion of the control unit 14 further includes first manually operable switch means represented by the "on" switch 20 for selectively triggering the second switching device represented by silicon-controlled rectifier 50. Switch 20 includes a spring-loaded normally-open switch blade 57 and a pair of switch contacts 58 and 59, the former being connected to connector wire 18 by way of a resistor 60 and the latter being connected to the gate electrode 53 of the silicon-controlled rectifier 50. A resistor 61 is connected between the gate electrode 53 and the lower connector wire 19.

The control circuit portion of the control unit 14 additionally includes second manually operable switch means represented by the "off" switch 21 for selectively disabling the control unit 14 or, for that matter, any of the other control units which may be in an activated condition when the switch 21 is operated. For the control unit 14, such control unit 14 is turned off by turning off the silicon-controlled rectifier 50. The "off" switch 21 includes first contact means represented by a movable spring-loaded contact member 62 and a movable spring-loaded switch blade 63 for triggering the silicon-controlled rectifier 50 if it is non-conductive. Contact member 62 is connected by way of a capacitor 64 to the gate electrode 53, while switch blade 63 is connected to the anode 51 of the silicon-controlled rectifier 50. The "off" switch 21 further includes second contact means represented by a stationa-

ry contact member 65 and the previously-considered movable switch blade 63 for breaking the circuit connection between the anode 51 of the silicon-controlled rectifier 50 and the gate electrode 47 of the first switching device 44.

"Off" switch 21 is a "make before break" type of switch and the mechanical coupling is such that the normally-closed second contact means represented by elements 65 and 63 is opened immediately following closure of the normally-open first contact means represented by elements 62 and 63. More particularly, switch 21 is shown in its normal or non-depressed position. The act of depressing the pushbutton for switch 21 moves the contact member 62 downward, causing it to make contact with the switch blade 63. The continued downward movement of contact member 62 thereafter pushes the switch blade 63 away from the stationary contact 65 so as to break the contact therebetween. When the pushbutton switch 21 is released, contact member 62 and switch 63 return to the positions shown in the drawing.

The second control unit 15 and any additional control units are of exactly the same construction as the first control unit 14. As such, the second control unit 15 includes an adjustable resistor 70 connected in series with a bilateral switching device 71 with this series combination being connected in parallel with the timing circuit resistor 32 in the dimmer unit 10 by way of connector wires 17 and 18. Control unit 15 further includes an "on" switch 72, an "off" switch 73 and a silicon-controlled rectifier 74, the latter being connected between the gate electrode of the bilateral switching device 71 and the third connector wire 19 by means of the "off" switch 73 and a resistor 75. A "commutating" capacitor 76 is connected between the second connector wire 18 and the "off" switch 73. The "off" switch 73 is of the same "make before break" type as previously considered and, as such, includes a movable contact member 77, a switch blade 78 and a stationary contact member 79. Contact member 77 is connected to the gate electrode of silicon-controlled rectifier 74 by way of a capacitor 80.

OPERATION OF THE ILLUSTRATED EMBODIMENT

Considering now the operation of the circuits shown in FIG. 2, each of the remote control units 14, 15, etc. is capable of turning on the dimmer unit 10 and lamp load 11, turning off the dimmer unit 10 and lamp load 11 and setting the brightness level for the lamp load 11 independently of and regardless of previous settings or conditions in any of the other control units.

It will first be assumed that none of the control units 14 and 15 (and any others) is in an activated or conductive condition. In this case, no direct current is being drawn from the direct current power supply circuit 23 and the relay switch 42 therein remains open. This opens the circuit for the dimmer relay coil 25 and causes the dimmer relay switch 26 to be open. With switch 26 open, dimmer unit 10 and lamp load 11 are turned off. Assuming now that the lamp load 11 is to be turned on by means of the control unit 14, this is accomplished by momentarily depressing the pushbutton "on" switch 20 to move the switch blade 57 against the stationary contact 58. This closure of switch 20 sup-

plies a pulse of current to the gate electrode 53 of the silicon-controlled rectifier 50. This turns on or renders conductive the silicon-controlled rectifier 50. This, in turn, causes direct current to flow by way of the connector wire 18, into the cathode 46 and out of the gate electrode 47 of the bilateral switching device 44, through resistor 54, switch contact member 65 and switch blade 63 of "off" switch 21, into the anode 51 and out of the cathode 52 of the silicon-controlled rectifier 50 and back to the direct-current power supply circuit 23 by way of the lower connector wire 19. Within the power supply circuit 23, this direct current flows through the relay coil winding 41 to close the switch 42. This enables the alternating line current to flow through the dimmer relay coil 25 to close the dimmer relay switch 26. This turns on the dimmer 10 and the lamp load 11.

When the silicon-controlled rectifier 50 is conductive, its internal anode-to-cathode impedance is very small. When turned on, the silicon-controlled rectifier 50 remains conductive until the voltage between the anode and cathode thereof is reduced to practically zero or reversed in polarity. With silicon-controlled rectifier 50 conductive, the commutating capacitor 55 charges up to a direct-current voltage level corresponding to the direct-current voltage difference between connector wires 18 and 19.

The direct current flow between the cathode 46 and the gate electrode 47 of the bilateral switching device 44 when the silicon-controlled rectifier 50 is conductive renders the bilateral switching device 44 conductive. This, in effect, connects the variable resistor 43 across the two connector wires 17 and 18 and, hence, in parallel with the timing circuit resistor 32 in the dimmer unit 10. This enables the variable resistor 43 to vary the resistance in the resistor-capacitor time constant circuit 31 and, hence, to vary the brightness of the lamp load 11. Increasing the time constant decreases the lamp brightness and vice versa.

When the silicon-controlled rectifier 50 is turned off, the bilateral switching device 44 is also turned off due to the absence of gate current flow between the cathode 46 and the gate electrode 47 thereof. This, in effect, disconnects the variable resistor 43 from the connector wires 17 and 18 so that it has no effect on the timing circuit 31 in the dimmer 10. Silicon-controlled rectifier 50 is turned off by momentarily depressing the pushbutton for the "off" switch 21. This breaks the connection between the stationary contact member 65 and the switch blade 63 to interrupt the direct current flow through silicon-controlled rectifier 50.

There will now be considered the case where one of the control units, for example, the first control unit 14, is conductive or turned on and it is desired to switch control of the dimmer 10 to another of the control units, for example, the second control unit 15. This is accomplished by momentarily depressing the pushbutton for the "on" switch 72 in the second unit 15. This turns on the silicon-controlled rectifier 74 in the second unit 15 and, at the same time, the commutating action of the commutating capacitor 76 in the second unit 14 turns off the silicon-controlled rectifier 50 in the first unit 14. In particular, the commutating capacitor 76 is initially discharged. When the silicon-con-

trolled rectifier 74 turns on, this, in effect, connects the lower end of the capacitor 76 to the lower connector wire 19. The commutating capacitor 55 in the first unit 14 then acts like a battery and causes a charging current to flow through the second capacitor 76, through the now-conductive second silicon-controlled rectifier 74 and through the first silicon-controlled rectifier 50 in the reverse direction. This reverse current flow through the first silicon-controlled rectifier 50 turns off such silicon-controlled rectifier 50. Thus, the second unit 15 is turned on and remains on and the first unit 14 is turned off and remains off. This commutating action is facilitated by the inductance of the relay coil winding 41 in the power supply 23, which relay coil winding 41, in effect, limits the magnitude of the direct current flow to the control units such that only one silicon-controlled rectifier may be in conduction at any given time.

With the second control unit 15 turned on, its bilateral switching device 71 is conductive and its variable resistor 70 is, in effect, connected in parallel across the timing circuit resistor 32 in the dimmer 10. At the same time, the bilateral switching device 44 in the first unit 14 is non-conductive so that the first variable resistor 43 is no longer connected to the dimmer timing circuit 31. Thus, the variable resistor in only one of the control units will have any effect on the dimmer timing circuit 31 at any given time.

There will now be considered the case where a first of the control units, for example, the control unit 14, is turned on and it is desired to turn the dimmer 10 and lamp load 11 off by manipulation of a second of the control units for example, the control unit 15, which at that moment is in an off condition. This is accomplished by momentarily depressing the pushbutton for the "off" switch 73 in the second unit 15. The first thing that happens is that the movable contact member 77 contacts the switch blade 78 in the switch 73. This triggers the silicon-controlled rectifier 74 to turn same on. This turns off the silicon-controlled rectifier 50 in the first unit 14 for the reason previously mentioned. This transfers control of the system to the second unit 15. Shortly thereafter, the continued movement of the switch blade 78 breaks the contact with the stationary contact member 79 in the switch 73. This breaks or opens the anode-to-cathode circuit of the silicon-controlled rectifier 74 to turn same off. With this accomplished, all of the control units 14, 15, etc. are now turned off. This discontinues the flow of current through the relay coil winding 41, causing relay switch 42 to open. This, in turn, opens the relay switch 26 in the dimmer 10, thus deactivating the dimmer 10 and turning off the lamp load 11.

Any desired number of control units can be connected to the system and, as seen from the foregoing, each of these control units is capable of turning on, turning off or setting the brightness level of the lamp load 11 regardless of the previous setting or condition of any of the other control units. At the same time, the system wiring remains quite simple regardless of the number of control units used since each control unit requires only three conductors and all of the control units are connected in parallel so that a three-wire bus may be utilized to pick up all of the control units throughout a given area.

While there has been described what is at present considered to be a preferred embodiment of this invention, it will be obvious to those skilled in the art that various changes and modifications may be made therein without departing from the invention, and it is, therefore, intended to cover all such changes and modifications as fall within the true spirit and scope of the invent.

What is claimed is:

1. A light dimming system comprising:
dimmer circuit means for controlling the current flow through a lamp load;
and a plurality of separate control units coupled to the dimmer circuit means and each including means for selectively activating and disabling the dimmer circuit means and adjustable means for modifying the control action of the dimmer circuit means.
2. A light dimming system in accordance with claim 1 wherein the adjustable means in each control unit is a variable resistor.
3. A light dimming system in accordance with claim 1 wherein the various control unit are connected in parallel with one another by conductor means having only three wires.
4. A light dimming system in accordance with claim 1 wherein each control unit includes means for automatically disabling the other control units when the activating means in any one of the control units is operated.
5. A light dimming system comprising:
dimmer circuit means having a control mechanism for determining the root-mean-square value of the current flow through a lamp load;
a plurality of separate control units each having an adjustable control mechanism and switch circuit means coupled in series therewith, this series combination being coupled in circuit with the dimmer circuit control mechanism, and manually operable control circuit means for activating and disabling the switch circuit means;
and common power supply means for energizing the individual control circuit means in the different control units, such power supply means including means for limiting the power supply current so that when the control circuit means in any given control unit is operated, the control circuit means in the other control units are automatically deactivated.
6. A light dimming system in accordance with claim 5 wherein the control mechanism in the dimmer circuit means includes a resistor-capacitor timing circuit and the control mechanisms in the control units are variable resistors and the variable resistor in any given control unit is connected in parallel with the resistor in the dimmer circuit timing circuit when the switch circuit means in that particular control unit is conductive.
7. A light dimming system in accordance with claim 5 wherein the control circuit means in each control unit includes a silicon-controlled rectifier and manually operable switch means connected in circuit with the gate electrode thereof for triggering such silicon-controlled rectifier.
8. A light dimming system in accordance with claim 5 wherein the dimmer circuit means includes switch

means for turning same on and off and the power supply circuit means includes a relay having a coil winding and switch contact means controlled thereby, such coil winding being connected in series in the output circuit of the power supply circuit means to provide the current limiting means thereof, the relay switch contact means being coupled to the dimmer circuit switch means for turning on the dimmer circuit means whenever one of the control units is drawing current from the power supply means.

9. A control unit for controlling the operation of a dimmer unit in a light dimming system comprising:

three connector means;

adjustable impedance means having a first end coupled to a first of the connector means;

a first switching device having a pair of power electrodes and a control electrode, a first of the power electrodes being coupled to a second end of the adjustable impedance means and a second of the power electrodes being coupled to a second of the connector means;

a second switching device having a pair of power electrodes and a control electrode, a first of the power electrodes being coupled to the control electrode of the first switching device and a second of the power electrodes being coupled to a third of the connector means;

capacitor means coupled between the second connector means and the first power electrode of the second switching device;

and manually operable switch means coupled to the control electrode of the second switching device for selectively triggering such second switching device.

10. A control unit in accordance with claim 9 wherein the first switching is a bilateral semiconductor switching device and the second switching device is a silicon-controlled rectifier.

11. A control unit in accordance with claim 9 and including second manually operable switch means coupled in circuit with the second switching device for selectively disabling such second switching device.

12. A control unit in accordance with claim 11 wherein the second manually operable switch means includes first contact means coupled to the control electrode of the second switching device for triggering same if it is non-conductive and second contact means mechanically coupled to the first contact means for breaking the circuit connection between the first power electrode of the second switching device and the control electrode of the first switching device immediately following closure of the first contact means.

* * * * *

30

35

40

45

50

55

60

65

UNITED STATES PATENT OFFICE
CERTIFICATE OF CORRECTION

Patent No. 3,697,821 Dated October 10, 1972

Inventor(s) James C. Johnson

It is certified that error appears in the above-identified patent and that said Letters Patent are hereby corrected as shown below:

Column 1, line 46, cancel "wherein", and insert -- a -- ;
cancel "switching device" and insert -- improved -- ; line
47, cancel "semiconductor" and insert -- employing -- ; line
48, cancel "device i" and insert -- remote -- . Column 8, line
30, cancel "anr" and insert -- any -- . Column 10, line 9,
cancel "wherdn" and insert -- wherein -- ; cancel "switchingis"
and insert -- switching is -- ; cancel "semikwnductor" and
insert -- semiconductor -- ; line 10, cancel "device 8" and
insert -- device -- .

Signed and sealed this 8th day of May 1973.

(SEAL)

Attest:

EDWARD M. FLETCHER, JR.
Attesting Officer

ROBERT GOTTSCHALK
Commissioner of Patents

UNITED STATES PATENT OFFICE
CERTIFICATE OF CORRECTION

Patent No. 3,697,821 Dated October 10, 1972

Inventor(s) James C. Johnson

It is certified that error appears in the above-identified patent and that said Letters Patent are hereby corrected as shown below:

Column 1, line 46, cancel "wherein", and insert -- a -- ; cancel "switching device" and insert -- improved -- ; line 47, cancel "semiconductor" and insert -- employing -- ; line 48, cancel "device i" and insert -- remote -- . Column 8, line 30, cancel "anr" and insert -- any -- . Column 10, line 9, cancel "wherdn" and insert -- wherein -- ; cancel "switchingis" and insert -- switching is -- ; cancel "semikwnductor" and insert -- semiconductor -- ; line 10, cancel "device 8" and insert -- device -- .

Signed and sealed this 8th day of May 1973.

(SEAL)
Attest:

EDWARD M. FLETCHER, JR.
Attesting Officer

ROBERT GOTTSCHALK
Commissioner of Patents