

19



Europäisches Patentamt
European Patent Office
Office européen des brevets



11 Publication number:

0 676 246 A1

12

EUROPEAN PATENT APPLICATION
published in accordance with Art.
158(3) EPC

21 Application number: **93921092.8**

51 Int. Cl.⁶: **B05B 15/04**

22 Date of filing: **29.09.93**

36 International application number:
PCT/JP93/01398

37 International publication number:
WO 95/09055 (06.04.95 95/15)

43 Date of publication of application:
11.10.95 Bulletin 95/41

84 Designated Contracting States:
DE FR GB

71 Applicant: **NAGOYA OILCHEMICAL CO., LTD.**
213-5 Honowari,
Minamishibata-cho
Tokai-shi,
Aichi 476 (JP)

72 Inventor: **HORIKI, Seinosuke, Nagoya**
Oilchemical Co.,Ltd.
213-5, Honowari
Minamishibata-cho
Tokai-shi
Aichi 476 (JP)
Inventor: **MAKINO, Reiji, Nagoya Oilchemical**

Co.,Ltd.
213-5, Honowari
Minamishibata-cho
Tokai-shi
Aichi 476 (JP)
Inventor: **KIOKA, Norihiko, Nagoya**
Oilchemical Co.,Ltd.
213-5, Honowari
Minamishibata-cho
Tokai-shi
Aichi 476 (JP)

74 Representative: **Senior, Alan Murray et al**
J.A. KEMP & CO.,
14 South Square,
Gray's Inn
London WC1R 5LX (GB)

54 **MASKING MEMBER.**

57 It is an object of the present invention to repeatedly use a masking member even in the case of surface treatment requiring heating at high temperature. In order to achieve this purpose, according to the present invention, the masking member is made of engineering plastics having high mechanical strength and high heat resistance.

EP 0 676 246 A1

[FIELD OF THE INVENTION]

The present invention relates to a masking member which is used to protect a part of an article from a surface treatment such as coating, plating and the like.

[DESCRIPTION OF THE PRIOR ART]

In case a part to be protected is a plane or a hole, a masking member having an adhesive layer is attached to the part through the adhesive layer. In case the part is a hole, a masking member having an inserting part is attached to the hole part by inserting said inserting part into the hole. In case the part is a panel, a masking member having a ditch is attached to the part by fitting the ditch to the panel. In case the part is a protrusion, a masking member having a fitting part is attached to the part by fitting the fitting part to the protrusion. And after the surface treatment, such masking members are removed from the parts respectively.

Hitherto, material consisting of thermoplastic resin mixed with inorganic filler has been provided for such masking members (TOKKAIHEI 2-126966).

Among the thermoplastic resin materials polyolefin especially has strong solvent resistance and is mechanically reinforced by mixing with inorganic filler, so that a thermal conductivity of which will increase and a thermal resistance of which will also increase; therefore, said masking members can be used repeatedly.

However, with respect to the above mentioned conventional masking members, thermal resistance of which is 150 °C at the highest even mixed with inorganic filler, and in a process of surface treatment which requires a temperature higher than 150 °C, the masking members are deformed.

[DISCLOSURE OF THE INVENTION]

As a means to solve the above described problem in the prior art, the present invention provides a masking member which is made of an engineering plastic.

[BRIEF DESCRIPTION OF THE DRAWINGS]

Figure 1 to Figure 3 relate to the first embodiment of the present invention.

Figure 1 is the perspective view of the first embodiment.

Figure 2 is the partial sectional view of the first embodiment when the masking member is attached.

Figure 3 is the partial sectional view of the first embodiment when the masking member is re-

moved.

Figure 4 to Figure 6 relate to the second embodiment of the present invention.

Figure 4 is the perspective view of the second embodiment.

Figure 5 is the partial sectional view of the second embodiment when the masking member is attached.

Figure 6 is the partial perspective view of the second embodiment when the masking members are produced.

Figure 7 is the perspective view of the third embodiment of the present invention.

Figure 8 to Figure 10 relate to the fourth embodiment of the present invention.

Figure 8 is the perspective view of the fourth embodiment.

Figure 9 is the partial sectional view of the fourth embodiment when the masking member is attached.

Figure 10 is another partial sectional view of the fourth embodiment when the masking member is attached.

Figure 11 and Figure 12 relate to the fifth embodiment of the present invention.

Figure 11 is the perspective view of the fifth embodiment.

Figure 12 is the partial sectional view of the fifth embodiment when the masking member is attached.

Figure 13 and Figure 14 relate to the sixth embodiment of the present invention.

Figure 13 is the perspective view of the sixth embodiment.

Figure 14 is the partial sectional view of the sixth embodiment when the masking member is attached.

Figure 15 is the perspective view of the seventh embodiment of the present invention.

Figure 16 is the perspective view of the eighth embodiment of the present invention.

Figure 17 and Figure 18 relate to the ninth embodiment of the present invention.

Figure 17 is the perspective view of the ninth embodiment.

Figure 18 is the partial sectional view of the ninth embodiment when the masking member is attached.

Figure 19 and Figure 20 relate to the tenth embodiment of the present invention.

Figure 19 is the perspective view of the tenth embodiment.

Figure 20 is the partial sectional view of the tenth embodiment when the masking member is attached.

Figure 21 to Figure 26 relate to the practical examples of the present invention.

Figure 21 is the perspective view of a car-body of

the practical example.

Figure 22 is the explanatory perspective view of Part A of the practical example.

Figure 23 is the explanatory perspective view of Part B of the practical example.

Figure 24 is the explanatory perspective view of Part C of the practical example.

Figure 25 is the explanatory perspective view of Part D of the practical example.

Figure 26 is the explanatory perspective view of Part E of the practical example.

Figure 27 and Figure 28 relate to the eleventh embodiment of the present invention.

Figure 27 is the perspective view of the eleventh embodiment.

Figure 28 is the sectional view of the eleventh embodiment when the masking member is attached.

Figure 29 to Figure 31 relate to the twelfth embodiment of the present invention.

Figure 29 is the perspective view of the twelfth embodiment before the masking member is attached.

Figure 30 is the sectional view taken along line A-A of Figure 29.

Figure 31 is the sectional view taken along line A-A of Figure 29 when the masking member is attached.

Figure 32 and Figure 33 relate to the thirteenth embodiment of the present invention.

Figure 32 is the perspective view of the thirteenth embodiment.

Figure 33 is the partial sectional view of the thirteenth embodiment when the masking member is attached.

Figure 34 to Figure 36 relate to the fourteenth embodiment of the present invention.

Figure 34 is the perspective view of the fourteenth embodiment.

Figure 35 is the partial sectional view of an inlet of fuel tank of the fourteenth embodiment.

Figure 36 is the explanatory sectional view of the fourteenth embodiment when adhesive layer is applied.

Figure 37 to Figure 40 relate to the fifteenth embodiment of the present invention.

Figure 37 is the perspective view of the fifteenth embodiment.

Figure 38 is the sectional view of the fifteenth embodiment when the masking member is attached.

Figure 39 is the front view of a group of masking members of the fifteenth embodiment.

Figure 40 is the front view of a masking member separated from the group of masking members of the fifteenth embodiment.

Figure 41 and Figure 42 relate to the sixteenth embodiment of the present invention.

Figure 41 is the perspective view of the sixteenth embodiment.

Figure 42 is the sectional view of the sixteenth embodiment when the masking member is attached.

Figure 43 to Figure 46 relate to the seventeenth embodiment of the present invention.

Figure 43 is the perspective view of the seventeenth embodiment.

Figure 44 is the sectional view of the seventeenth embodiment when the masking member is provisionally fixed.

Figure 45 is the sectional view of the seventeenth embodiment when the masking member is attached.

Figure 46 is the front view of the seventeenth embodiment when the masking member is attached.

In the drawings,

- (1) article
- (11) car-body
- (12) underside of car body
- (13) bumper
- (14) inlet of fuel tank
- (15) pillar
- (2) part being protected
- (21) protrusion
- (22) hole
- (23) extending part
- (31)~ (317) masking member
- (31A) ~ (316A) body
- (4) coating layer

[DETAIL DESCRIPTION OF THE INVENTION]

An engineering plastic used in the present invention is such as: thermoplastic-type engineering plastic such as methylpentene copolymer (TPX), polyethylene terephthalate (PET), polyamide (PA), polycarbonate (PC), cellulose acetate (CA), polysulphone (PSF), polyethersulphone (PES), polyphenylene sulphide (PPS), polyphenylene ether (PPE), polyamideimide (PAI), polyetherimide (PEI), polyether-etherketone (PEEK), polyimide (PI), polyester (PE), polyamide such as nylon 6 and nylon

66, polybutylene terephthalate (PBT), polyallylester (PAE), polyethylene naphthalate (PEN), polyallylate (PAR), polyvinylidene fluoride (PVF₂) and the like; liquid crystal-type engineering plastic such as polyallylether and the like; compression molding-type engineering plastic such as fluororesin and the like; amorphous polymer; aminobimaleimide; bimaleimidoazine thermosetting aromatic polyimide; and the like. The above described engineering plastic may be foamed plastic and two or more kinds of said engineering plastics may be mixed or laminated together.

A filler or a reinforcing material such as calcium carbonate, magnesium carbonate, barium sulphate, calcium sulfite, magnesium hydroxide, aluminum hydroxide, magnesium oxide, titan white, iron oxide, zinc oxide, alumina, silica diatom earth, dolomite, gypsum, talc, clay, asbestos, mica, calcium silicate, bellonite, white carbon, carbon black, iron powder, aluminum powder, stone powder, blast furnace slag, flyash, synthetic fiber, natural fiber, glass fiber, carbon fiber, ceramic fiber, whisker and the like may be mixed in the engineering plastic. 10 to 200 % by weight of said filler is commonly mixed with said engineering plastic.

Further, one or more kind of: thermoplastic resin such as polyolefin such as polyethylene, polypropylene, ethylene-propylene copolymer, ethylene-vinylacetate copolymer and the like, polyvinyl chloride, polystyrene, polymethacrylate, polyvinylidene chloride, styrene-butadiene copolymer, polyamide and the like; plastic foam of the above described thermoplastic resin; polyurethane foam; and the like, may be mixed or laminated with the engineering plastic. A desirable engineering plastic is a polymer alloy such as PPE and polyamide, high-impact polystyrene, polystyrene and the like.

A surface treatment such as corona discharge treatment, primer coating treatment and the like is preferably effected on the surface of the engineering plastic to increase its affinity with paint or adhesive. Also releasing treatment may be effected on the surface of said engineering plastic to decrease its affinity with paint or adhesive. A primer used in the primer coating treatment is, for example: synthetic rubber such as modified polyolefin or olefin copolymer such as chlorinated polypropylene or ethylene-vinylacetate copolymer, styrene-butadiene rubber, acrylonitrile-butadiene rubber, chloroprene rubber, polybutadiene and the like; synthetic resin such as acrylic synthetic resin, vinyl synthetic resin, acrylic synthetic resin including amino group and/or amide, vinyl synthetic resin including amino group and/or amide, amino synthetic resin, epoxy synthetic resin and the like; and low-molecular weight primer such as aluminium alcoholate or aluminium chelate agent such as aluminium isopropylate, aluminium triacetylacetonate

and the like; alkyl metal such as 2-ethylhexyl lead, hexadecyl lithium and the like; organotin compound such as dibutyl tin diacetate, di-n-butyl tin dioxide and the like; silane compound such as methylvinyl dichloro silane and the like; metal complex salt of 1, 3-dicarbonyl compound such as acetyl acetone lithium, acetylacetone beryllium and the like; organotitan compound such as tetrabutyl titanate and the like; boric acid compound such as tri-n-butyl borate, triphenyl borate and the like; phosphate such as trioleil phosphate, tridecyl phosphate and the like; metal salt of a carboxylic acid such as magnesium stearate, cobalt naphthenic acid and the like; metal thioalcoholate such as n-potassium dodecylmercapto chloride and the like; thiodicarboxylate such as 2-ethylhexane dithio acid zinc and the like; metal salt of a dithiocarbamic acid such as nickel dimethyldithiocarbamate, copper dimethyldithiocarbamate and the like; metal salt of sulfonic acid such as nickel benzenesulfonate and the like; organophosphate compound such as dibutylvanadium phosphate and the like. One or more kinds of said primers may be mixed together.

Said primer has affinity with both said engineering plastic and synthetic resin other than said engineering plastic which is generally used as a paint vehicle or an adhesive for said engineering plastic. A preferable primer is an acrylic synthetic resin containing quarternary ammonium salt or a synthetic resin containing amino group. For the primer coating treatment, a solution or an emulsion of one or more kinds of said primer is coated on the surface of said engineering plastic as the material for the masking member and then dried.

Prior to said primer coating treatment, an affinity treatment may be effected on the surface of said engineering plastic. The examples of said affinity treatment are flame treatment, sulfuric acid treatment, corona discharge treatment and the like, and the surface of said engineering plastic is slightly carbonyzed by said treatment to obtain the affinity with other synthetic resin.

Further, the examples of a release agent used for the surface treatment of said engineering plastic are a silicone type release agent, a fluoro type release agent, a fatty acid type release agent, a paraffine type release agent, a wax type release agent and the like.

For releasing treatment, a solution or an emulsion of one or more kinds of said releasing agent or melted releasing agent is coated on the surface of said engineering plastic and then dried or cooled.

Said engineering plastic may be colored by a pigment or a dyestuff to discriminate the masking parts, and also, a flame-retardant, an insecticide, an antiseptic, an antioxidant, an ultraviolet absorber, a blowing agent such as a chemical blowing agent, a

capsule type blowing agent and the like, and the like may be mixed with said engineering plastic. Two or more kinds of said agents may be mixed and then added to said engineering plastic.

To manufacture the masking member by using said engineering plastic as a material, commonly the vacuum-forming method in which a film or a sheet of said engineering plastic is vacuum-formed is most appropriate because it is the most suitable method for mass-production, however, press molding method, blow molding method, injection molding method and the like may be applied to manufacture the masking member. Both unstretched film or sheet and stretched film or sheet of said engineering plastic may be used to manufacture the masking member.

Said engineering plastic has a high heat resistance and the masking member made of said engineering plastic has a high mechanical strength and said masking member does not soften or deformed even at a temperature higher than 150 °C .

Accordingly, in the present invention, the masking member can be used repeatedly even in the surface treatment having a heating process at a high temperature.

[Masking member Type A]

Masking member Type A is used to protect the even surface of an article.

Figure 1 to Figure 3 relate to the first embodiment of the present invention. Referring now to Fig. 1 to Fig. 3, a masking member (31) comprises a body (31A) having a vessel form consisting of a rectangular bottom and an adhesive layer (31B) formed on the under surface of said body (31A), with said body (31A) manufactured by vacuum forming of a sheet consisting of polyphenylenesulfide in which 50% by weight of calcium carbonate is mixed. Said adhesive layer (31B) is covered with a release sheet (31C) such as a polyethylene film, a polypropylene film, a release paper and the like to prevent sticking to another article, the hands of workers and the like when the masking members are handled, stacked, transported, kept and the like.

When said masking member (31) is used, said release sheet (31C) is removed from said adhesive layer (31B) and said masking member (31) is then attached to an even part (2) of the surface of an article (1) by said adhesive layer (31B) thereof, which is necessary to be protected from a surface treatment. After said masking member (31) is attached to said part (2), for example, a coating material is coated on the surface of said article (1) by spraying as shown in Fig. 2. Said part (2) of said surface of said article (1) is not subjected to said coating since said part (2) is covered with said

masking member (31). Said part (2) may have hole(s) and in this case, said hole(s) is (are) also not subjected to said coating.

After or before said coated article (1) is heated to dry and/or cure if desired, and said masking member (31) may be removed by a worker's hand as shown in Fig. 3.

Said masking member (31) consisting of the above-mentioned sheet is easily manufactured by vacuum forming and can be reused without deformation.

Further in a case when a silicone treatment is effected on the surface of said masking member (31), affinity of the surface of said masking member (31) with the paint reduces and the film of the paint is easily peeled from the surface of said masking member (31) so that said masking member (31) can be repeatedly used after peeling the film of the paint.

Figure 4 to Figure 6 relate to the second embodiment of the present invention. Referring now to Fig. 4 to Fig. 6, a masking member (32) comprises a body (32A) having a vessel form consisting of a rectangular bottom and perpendicular walls which extend upwards from the perimeter of said bottom, and a flange (32B) which is extended from the upper edges of said walls and an adhesive layer (32C) formed on the under surface of said body (32A), with said body (32A) manufactured by vacuum forming of a sheet consisting of polyethylene terephthalate in which 30% by weight of talc is mixed. An adhesive layer (32C) is formed on the under surface of said body (32A) and said adhesive layer (32C) is covered with a release sheet (32D). Said masking member (32) is attached to an even part (2) of the surface of an article (1) the same as the first embodiment of the present invention.

In this embodiment, said coating layer (4) is cut by said flange (32B) of said masking member (32) as shown in Fig. 5. As the results, said masking member (32) may be smoothly removed from said part (2) of said surface of said article (1) by a worker's hand without obstruction of said coating layer (4). Said masking member (32) is easily manufactured by vacuum forming and can be reused the same as the first embodiment.

A number of masking members (32) of this embodiment may advantageously be produced by vacuum forming, if desired. Referring to Fig. 6, a number of bodies (32A) of masking member (32) are formed arranged in rows and lines, and each body (32A) is connected to the other body (32A) by the flange (32B). Cutting lines (32E) or grooves are formed between said flange (32B) and another said flange (32B) and when said masking member (32) is used, said masking member (32) is broken along said cutting lines (32E) or grooves by hand. Said cutting lines (32E) or grooves may be

formed simultaneously with vacuum forming or after vacuum forming.

Figure 7 relates to the third embodiment of the present invention. In this embodiment, a masking member (33) comprised a body (33A) having a vessel form consisting of a rectangular bottom from which a grip (33D) is risen and perpendicular walls which extend upwards from the perimeter of said bottom and an adhesive layer (33B) formed on the under surface of said body (33A), with said body (33A) manufactured by vacuum forming of a sheet consisting of polyamide in which 40% by weight of calcium carbonate is mixed. Said adhesive layer (33B) is covered with a release sheet (33C) the same as the first embodiment. The masking member (33) of this embodiment is easily handled by holding said grip (33D) of said masking member (33) and is easily manufactured by vacuum forming and can be reused the same as the first embodiment.

[Masking member Type B]

Masking member Type B is used to protect an even surface or a protruding part of an article. Said masking member B is manufactured by vacuum forming of two layers sheets consisting of polyetherester imide in which 30% by weight of glass fiber is mixed and polypropylene sheet in which 15% by weight of calcium carbonate and 5% by weight of styrene-butadiene elastomer is mixed.

Figure 8 and Figure 9 relate to a fourth embodiment of the present invention. Referring now to Fig. 8 and Figure 9, a masking member (34) comprises a body (34A) having a vessel form consisting of a rectangular bottom, perpendicular walls which extend upwards from the perimeter of said bottom, a flange (34B) which is extended from the upper edges of said walls, and an adhesive layer (34C) formed on the surface of said flange (34B). Said adhesive layer (34C) is covered with a release sheet (34D).

Referring to Figure 9, when said masking member (34) is used, said release sheet (34D) is removed from said adhesive layer (34C) and said masking member (34) is then attached to an even part (2) of the surface of an article (1) by said adhesive layer (34C) thereof. After said masking member (34) is attached to said part (2) of said surface of said article (1) is not subjected to said coating since said part (2) is covered with said masking member (34). After forming a coating layer (4), said masking member is removed by a worker's hand. Further, said even part (2) may have hole(s). And further, as shown in Figure 10, said masking member (34) is also used to protect a protruding part (21) of said article (1) by covering said protruding part (21) with said masking mem-

ber (34). Said masking member (34) is easily manufactured by vacuum forming and can be reused without deformation.

Figure 11 and Figure 12 relate to the fifth embodiment of the present invention. In this embodiment, a masking member (35) comprises a body (35A) having a vessel form consisting of a circular bottom, an inner perpendicular wall which extends upwards from the circumference of said bottom, a flange (35B) which is extended from the upper edge of said wall, and an outer perpendicular wall (35C) which extends downwards from the perimeter of said flange (35B), and an adhesive layer (35D) formed on the surface of said flange (35B). Said adhesive layer (35D) is covered with a release sheet (35E).

When said masking member (35) is used, said release sheet (35E) is removed from said adhesive layer (35D) and said masking member (35) is then attached to an even part (2) of the surface of an article (1) by said adhesive layer (35D) thereof, and said part (2) has a hole (22). After said masking member (35) is attached to said part (2), a coating is effected on the surface of said article (1) to form a coating layer (4) as shown in Fig. 12. Said masking member (35) can be removed from said part (2) of said article (1) by a worker's hand without obstruction of said coating layer (4). Said masking member (35) is easily manufactured by vacuum forming and can be reused the same as the fourth embodiment. Further, said part (2) of said article (1) may be an even part without hole (22).

[Masking member Type C]

Masking member Type C is used to protect hole(s) of an article. Said masking member C is manufactured by vacuum forming of a sheet consisting of methylpentene copolymer.

Figure 13 and Figure 14 relate to the sixth embodiment of the present invention. In this embodiment, a masking member (36) consists of an inserting part (36A) having a vessel form consisting of a circular bottom and a perpendicular wall which extends upwards from the circumference of said bottom, and a flange (36B) which is extended from the upper edge of said wall.

When said masking member (36) is used, said masking member (36) protects the inside of a hole (22) of an article (1) by inserting said inserting part (36A) into said hole (22) as shown in Fig. 14 and said flange (36B) of said masking member (36) covers the surroundings of said hole (22). After which, a coating is effected on the surface of said article (1) to form a coating layer (4) and the inside and surroundings of said hole (22) are not subjected to said coating. After said coating, said

masking member (36) may be removed from said hole (22) by hand. As said masking member (36) has a good heat resistance and does not deform during curing process of said coating layer (4), said masking member can be reused.

Further in a case where the primer coating treatment using an acrylic synthetic resin including a quaternary ammonium salt is effected on the surface of said masking member (36), the film of the paint may be strongly bonded with the surface of said masking member (36) and after the heating treatment, said film of the paint does not peel from the surface of said masking member (36) so that pieces of the film of the paint peeling from the surface of said masking member (36) are not formed to avoid contamination of the circumference by said pieces of the film of the paint. Accordingly, said masking member (36) may be preferably used repeatedly without peeling the film of the paint.

Figure 15 relates to the seventh embodiment of the present invention. In this embodiment, a masking member (37) comprises an inserting part (37A) having a vessel form consisting of a circular bottom from which a grip (37C) is risen, and perpendicular wall which extends upwards from the circumference of said bottom, and a flange (37B) which is extended from the upper edge of said wall. The masking member (37) of this embodiment is used the same as the sixth embodiment and is easily handled by holding said grip (37C) when said masking member (37) is inserted into the hole of the article or removed from the hole. Said masking member (37) is easily manufactured by vacuum forming and can be reused the same as the sixth embodiment.

Figure 16 relates to the eighth embodiment of the present invention. In this embodiment, a masking member (38) consists of an inserting part (38A) having vessel form consisting of a cross-shaped bottom and a perpendicular wall which extends upwards from the perimeter of said bottom, a flange (38B) which is extended from the upper edge of said wall, and a perpendicular wall (38C) which extends upwards from the circumference of said flange (38B).

Said masking member (38) is inserted into a hole (22) of the article (1) by said inserting part (38A) the same as the sixth embodiment and further said masking member (38) is supported in the inner wall of said hole by only partially contacts at the tips of said inserting part (38A) so that attaching and removing of said masking member (38) to/from the hole may be very easy. Further, the material of said masking member (38) may be less than the masking member having cylindrical form.

Figure 17 and Figure 18 relate to the ninth embodiment of the present invention. In this embodiment, a masking member (39) consists of an

inserting part (39A) having vessel form consisting of circular bottom from which a grip (39E) is risen and an inner perpendicular wall which extends upwards from the circumference of said bottom, a lower flange (39B) which is extended from the upper part of said wall, an outer perpendicular wall (39C) which extends upwards from the circumference of said lower flange (39B), and an upper flange (39D) which is extended from the upper part of said wall (39C), and plural radiated grooves (39F) and (39G) are respectively formed in said lower flange (39B) and said upper flange (39D).

As shown in Figure 18 said masking member (39) is inserted into a hole (22) of an article (1) the same as the sixth embodiment and since a coating layer (4) may be cut by said upper flange (39D) of said masking member (39), the removing of said masking member (39) from said hole (22) may be very smooth without obstruction of said coating layer (4) and further said grooves (39F) and (39G) respectively reinforce said lower and upper flanges (39B) and (39D). Said masking member (37) is easily manufactured by vacuum forming and can be reused the same as the sixth embodiment.

[Masking member Type-D]

Masking member Type D is used to protect the extending part of the article and manufactured by vacuum forming of a sheet consisting of polycarbonate in which 50% by weight of calcium carbonate is mixed.

Figure 19 and Figure 20 relate to the tenth embodiment of the present invention. In this embodiment, a masking member (310) consists of a body (310A) having a cylindrical vessel form, which has a slit (310B) formed from the opening end of said body (310A). An extending part (23) of the article (1) to be protected is inserted into said slit (310B) of said masking member (310) and the coating layer (4) is not formed on said extending part (23) since said extending part (23) is protected by said masking member (310) as shown in Figure 20. After coating, said masking member (310) is removed from said extending part (23) by a worker's hand. Said masking member (310) is easily manufactured by vacuum forming and can be reused.

Figure 21 to Figure 26 relate to an applied embodiment in which the masking members Type A, B, C and D are piled to the under side (12) of the car body (11) for corrosion, sound and vibration-proof.

As shown in Fig. 21, the masking members of the present invention are attached to parts A, B, C, D and E of the under side (12) of a car body (11). Namely, as shown in Figure 22, the masking member Type C, such as said masking member (36) of

the sixth embodiment may be attached to a hole (22A) of part A into which a spring axis of a forward wheel is inserted and the circumference of the hole (22A) is used as a bed for the spring.

As shown in Figure 23, the masking member Type B, such as said Type B masking member (35) of the fifth embodiment is attached to a bolt (21A) of part B.

As shown in Figure 24, the Type C masking member (37) of the seventh embodiment is inserted into a drainage hole (22B), as shown in Figure 25, the masking member (310) of the tenth embodiment is attached to a bracket (23A) of part D, and as shown in Figure 26, the Type A masking member (31) of the first embodiment is attached to a screw hole (22C). Thus, said hole (22A), said bolt (21A), said drainage hole (22B), said bracket (23A) and said screw hole (22C) are protected by said masking members of the present invention from coating.

Figure 27 and Figure 28 relate to the eleventh embodiment of the present invention. A masking member (311) is used to protect a bumper (13), and a fitting part (311A) which is fitted in an air-intake (13A) of said bumper (13), a flange (311B) having a C-shaped cross section on the lower edge of said fitting part (311A), and horizontal ribs (311C),(311D) and vertical ribs (311E),(311F) for reinforcement are formed in said masking member (311).

when the masking member (311) is attached to the bumper (13) by fitting the fitting part (311A) in the air-intake (13A) of said bumper (13), as said fitting part (311A) of said masking member (311) is reinforced by the flange (311B) and prevented from obstruction, fitting is easily achieved. In addition, since the surface of said flange (311B) is substantially on the same plane as the lower edge of said air-intake (13A) of said bumper (13) in this state, as shown in Fig. 28, it can be easily fixed thereover by the adhesive tape (311G). Material for the masking member (311) of the above described embodiment is engineering plastic in which polyamide is mixed with PPE.

Figure 29 to Figure 31 relate to the twelfth embodiment of the present invention. A masking member (312) of this embodiment is also used to protect a bumper (13). A pair of air-intakes (13A),(13A) is formed on said bumper (13), and vertical ribs (13C),(13C) and horizontal ribs (13D),(13D) are formed in the inside of said air-intakes (13A),(13A), and further grooves (13B),(13B) are formed on the upper edge of the air-intakes (13A),(13A) as shown in Figure 30. Flight parts (13E),(13E) are also formed on the lower edge of the air-intakes (13A),(13A).

Said masking member (312) is to protect the air-intakes (13A),(13A) of the bumper (13) from

coating, and the masking member (312) has a pair of fitting parts (312A),(312A) which is fitted in the air-intakes (13A),(13A) of said bumper (13). On the upper edge of said fitting parts (312A),(312A), fitting flanges (312B),(312B) are formed. On the lower edge of said fitting parts (312A),(312A) C-shaped bends (312C),(312C) are formed. Also horizontal fitting ribs (312D),(312D) and vertical fitting ribs (312C),(312C) are formed on said fitting parts (312A),(312A) of said masking member (312).

When the masking member (312) is attached to the bumper (13) by fitting the fitting parts (312A),(312A) in the air-intakes (13A),(13A) and fitting a horizontal ribs (13D),(13D) and vertical ribs (13C),(13C) of the air-intakes (13A),(13A) respectively in horizontal fitting ribs (312D),(312D) and vertical fitting ribs (312E),(312E). As shown in Figure 31, fitting flange (312B),(312B) on the upper edge of the fitting parts (312A),(312B) of said masking member (312) is fitted in grooves (13B),(13B) without using adhesive tape.

Since the lower edge of the fitting parts (312A),(312A) is reinforced by the bends (312C),(312C) and is protected from deformation, fitting is easily achieved. Since the surface of said bends (312C),(312C) is substantially on the same plane as the flight parts (13E),(13E) of said air-intakes (13A),(13A) of the bumper (13) in this state, as shown in Fig. 31, it can be easily fixed thereover by the adhesive tape (312F). Material for the masking member (312) of the embodiment is the engineering plastic of the eleventh embodiment.

Figure 32 and Figure 33 relate to the thirteenth embodiment of the present invention. In this embodiment, a masking member (313) is used to protect plural protrusions (21),(21) of an article from a surface treatment. Said masking member (313) comprises a body (313A) and fitting parts (313B),(313B) projected from said body (313A).

Said masking member (313) is attached to said plural protrusions (21),(21) of an article by said fitting parts (313B),(313B) to protect said parts (21),(21) of said article from said surface treatment as shown in Figure 33.

Said masking member (313) is easily manufactured by vacuum forming of two layers sheet and can be reused the same as the fourth embodiment.

Figure 34 to Figure 36 relate to the fourteen embodiment of the present invention. In the figures, an inlet (14) of the fuel tank of the car consists of a hole part (14A), an inner flange part (14B) surrounding said hole part (14A), and an outer flange part (14C) formed at the outside of said inner flange part (14B) intermedating a packing groove (14D) and said inner flange part (14B) is slightly higher than said outer flange part (14C).

A masking member (314) consists of a central disk part (314A), an outer ring part (314C) sur-

rounding said central disk part (314A) intermediating a guide groove (314B), a grip (314D) projecting from said central disk part (314A) and an adhesive layer (314E) formed on the backside of said outer ring part (314C) and said masking member (314) is manufactured by the vacuum forming of a polymer alloy film consisting of PPE and polyamide containing 30% by weight of calcium carbonate.

When said masking member (314) is attached to said inlet (14), the position of said masking member (314) is adjusted by inserting said inner flange part (14B) of said inlet (14) into said guide groove (314B) of said masking member (314) and then said adhesive layer (314E) of said outer ring part (314C) is pressed to the top of said outer flange part (14C) as shown in Figure 35 and the paint is prevented from going into the fuel tank through said inlet (14) by said masking member (314).

As no projecting part rising from said outer ring part (314C) in the backside of said masking member (314), the adhesive can be applied on the backside of said outer ring part (314C) to form said adhesive layer by a roll coater (5) as shown in Figure 36.

Figure 37 to Figure 40 relate to the fifteenth embodiment of the present invention. In the figures, a masking member (315) consists of a body (315A) inside of which an inserting part (315B) for a pillar body (15A) of a pillar member (15) is formed and a pair of flange inserting parts (315D),(315D) formed along the lower end of side walls (315C),(315C) of said body (315A) and in which a pair of flanges (15D),(15D) are respectively inserted and reinforcing ribs (315E) are formed on the circumference of said body. Said masking member (315) is manufactured by the same method using the same material as the fourteenth embodiment.

Said masking member (315) is attached to said pillar member (15) and said pillar member (15) is constituted by an outer panel (15A) and an inner panel (15B) and consists of a pillar body (15A) and flanges (15D),(15D) formed along the lower ends of a pair of side walls (15C),(15C).

Said masking member (315) is attached to said pillar member (15) by inserting said pillar body (15A) into said inserting part (315B) of said masking member (315) and inserting flanges (15D),(15D) of said pillar body (15A) into said flange inserting parts (315D),(315D) of said masking member (315) respectively as shown in Figure 38. After said masking member (315) is attached to said pillar member (15) as above described, a surface treatment such as a coating, plating or the like is effected and after said surface treatment, said masking member (315) is removed from said pillar member (15).

To manufacture said masking member (315), first a masking member assemblage (315G) consisting of a plural number of said masking members (315) connected respectively through connecting parts (315F) is molded by the vacuum forming, press molding, and the like using a thermoplastic resin sheet as shown in Figure 39, and then said masking member assemblage (315G) is cut by a cutter (6) at said connecting parts (315F) as shown in Figure 40 and the resulting cut parts are further cut along dotted lines shown in Figure 40 by a cutter, a shears or the like to obtain said masking member (315).

Figure 41 and Figure 42 relate to the sixteenth embodiment of the present invention. A masking member (316) in this embodiment consists of a body (316A) inside of which an inserting part (316B) for a pillar body (15A) of a pillar member (15) is formed, and projections (316F) formed on the insides of a pair of lower side walls (316E),(316E) which are formed respectively along the lower ends of a pair of side walls (316C),(316C) of said pillar body (316A) intermediating flight parts (316H)(316H), and flange inserting parts (316D),(316D) are formed upon said projections (316F) and further reinforcing ribs (316G) are formed on the circumference of said body (316A).

Said masking member (316) is made of a polymer alloy consisting of PPE and polystyrene containing 30% by weight of calcium carbonate and is manufactured by vacuum forming using said polymer alloy sheet.

Said masking member (316) is attached to a pillar member (15) by inserting a pillar body (15A) of said pillar member (15) into said inserting part (316B) of said masking member (316) and inserting flanges (15D),(15D) of said pillar member (15) into said flange inserting parts (316D),(316D) of said masking member (316) as shown in Figure 42.

Figure 43 to Figure 46 relate to the seventeenth embodiment of the present invention. A masking member (317) shown in Figure 43 consists of a body (317A) inside of which an inserting part (317B) of a pillar body (15A) of a pillar member (15) is formed, flange inserting parts (317D),(317D) into which flanges (15D),(15D) of said pillar member formed along a pair of side walls (317C),(317C) of said body (317A) is inserted, a pair of back sheets (317E),(317E) extending from said flange inserting parts (317D),(317D), and an upper sheet (317F) extending from the upper end of said body (317A), and reinforcing ribs (317G) are formed on the circumference of said body (317A) and said masking member (317) is manufactured by the same method using the same material as the sixteenth embodiment. Said masking member (317) is provisionally attached to a pillar body (15A) of a pillar member (15) shown in Figure 44 by

inserting said pillar body (15A) into said inserting part (317B) of said masking member (317) as shown in Figure 44 and inserting said flanges (15D),(15D) of said pillar member (15) into said flange inserting parts (317D),(317D), respectively as described in the fourteenth embodiment. 5

After said masking member (317) is provisionally attached to said pillar member (15), said back sheets (317E),(317E) are respectively turned over to be attached to the back side of said pillar member (15) and said back sheets (317E),(317E) are mutually fixed by such as an adhesive tape (317H), a tacker, or the like as show in Figure 45. 10

As above described, after said masking member (317) is attached to said pillar member (15) as shown in Figure 46, a surface treatment such as a coating, a plating or the like is effected. Since the back side of said pillar member (15) is covered with said back sheets (317E),(317E) of said masking member (317), said surface treatment is not effected on the backside of said pillar member (15). After said surface treatment, said masking member (317) is removed from said pillar member (15) by peeling off said adhesive tape (317H) from back sheets (317E),(317E) of said masking member (317). 15 20 25

Claims

- 1. A masking member made of an engineering plastic 30

35

40

45

50

55

10

Fig. 1

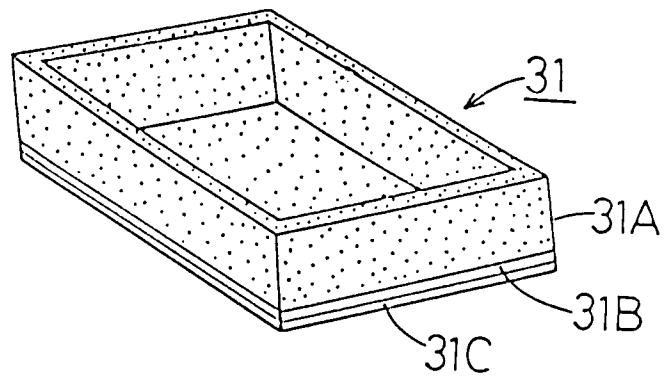

Fig. 2

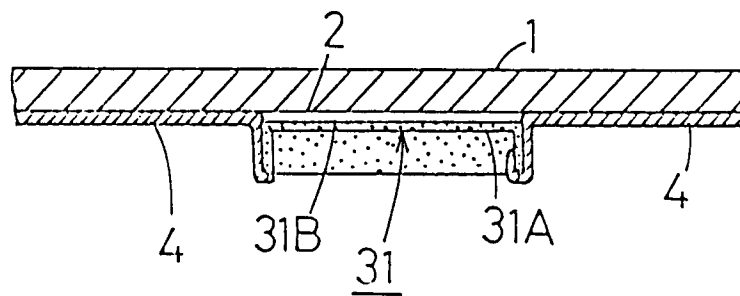

Fig. 3

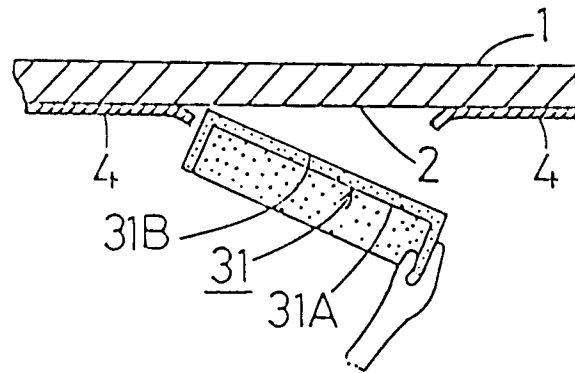

Fig. 4

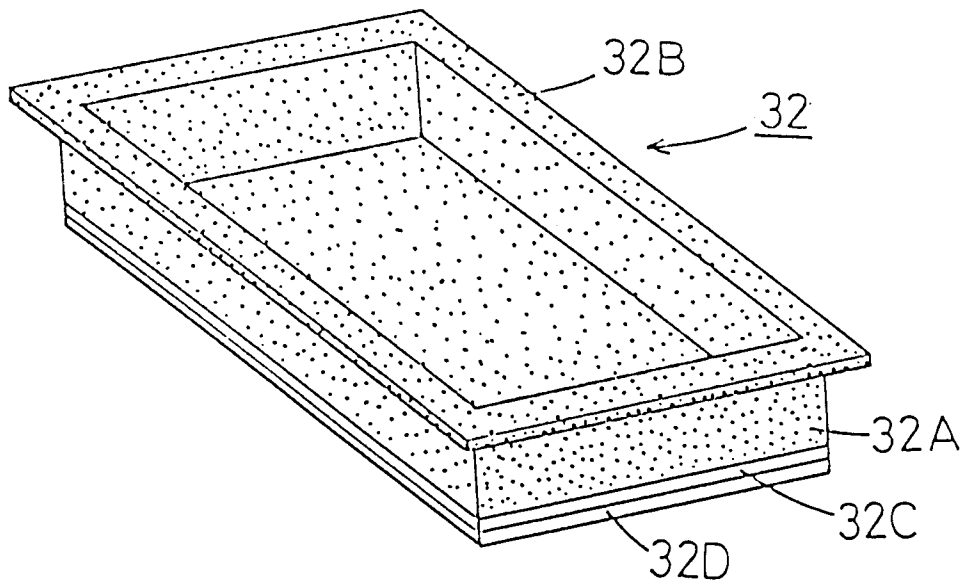

Fig. 5

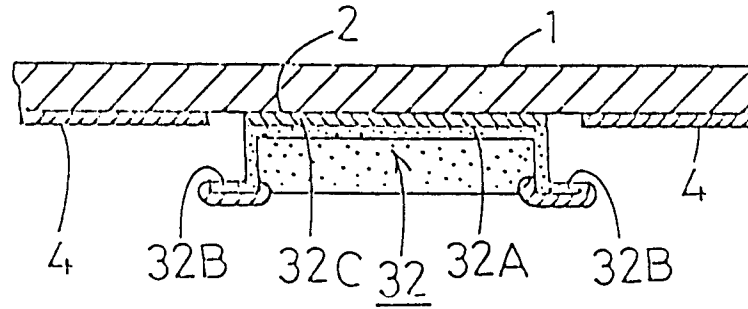

Fig. 6

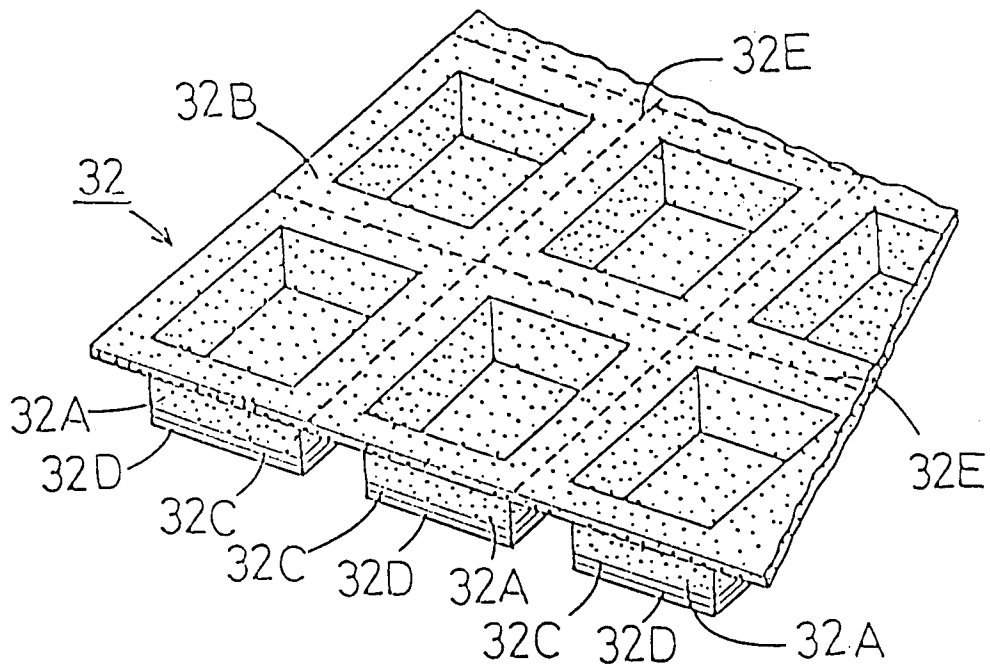

Fig. 7

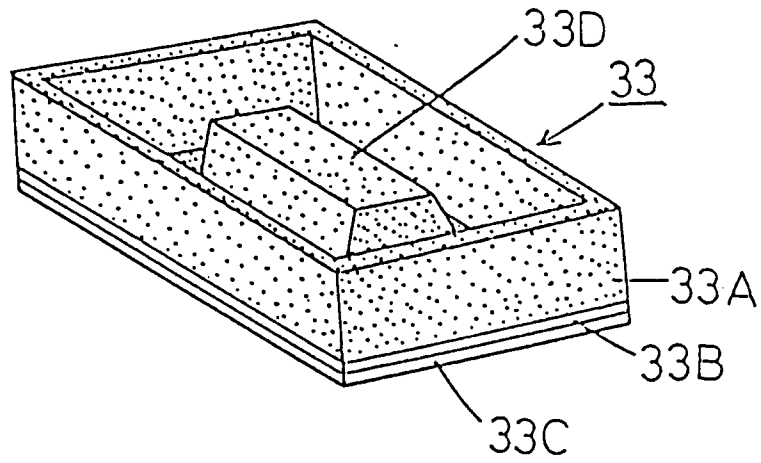

Fig. 8

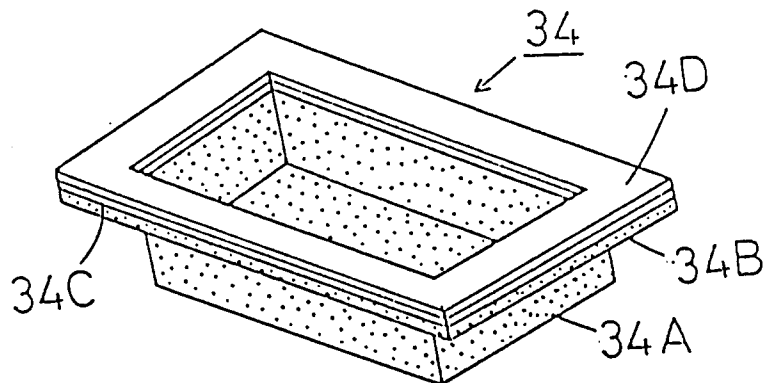

Fig. 9

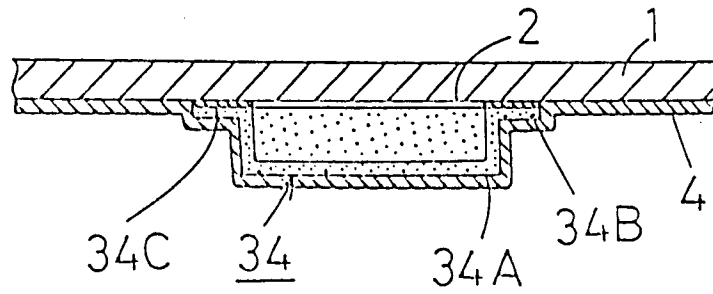

Fig. 10

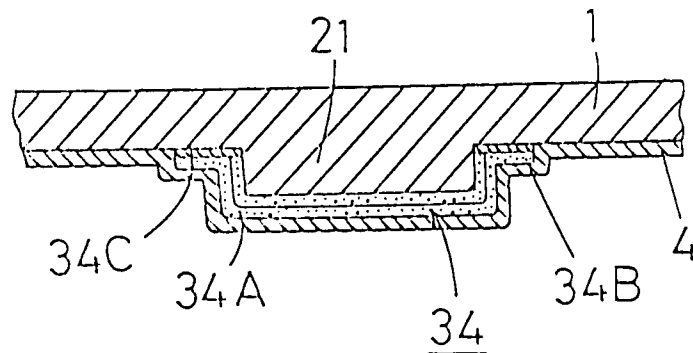

Fig. 11

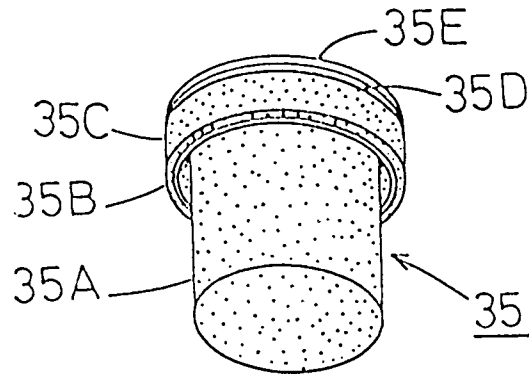

Fig. 12

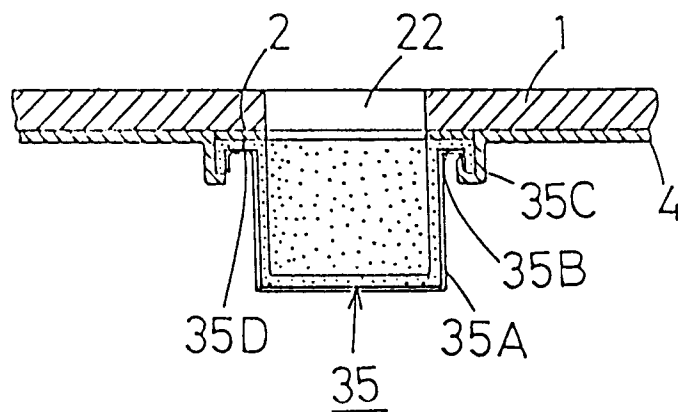

Fig. 13

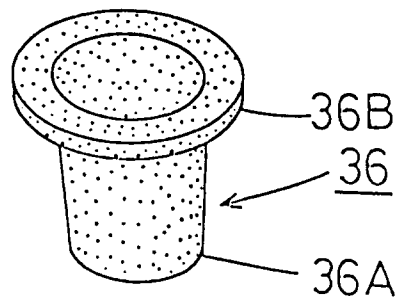

Fig. 14

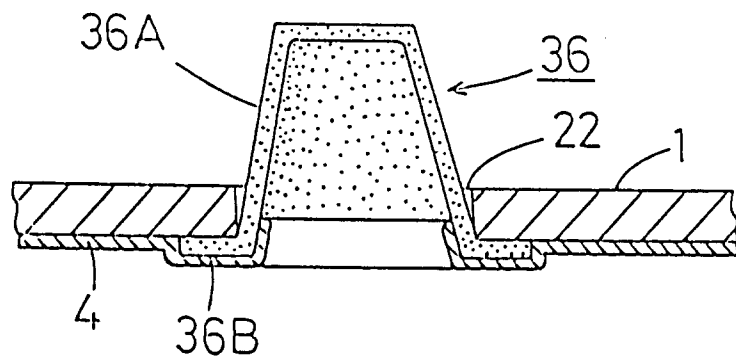

Fig. 15

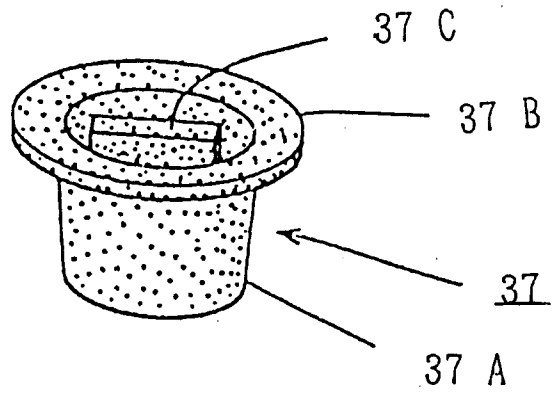

Fig. 16

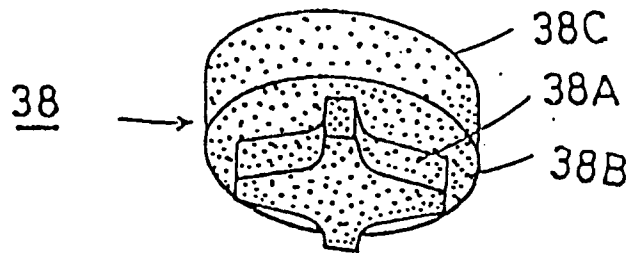

Fig. 17

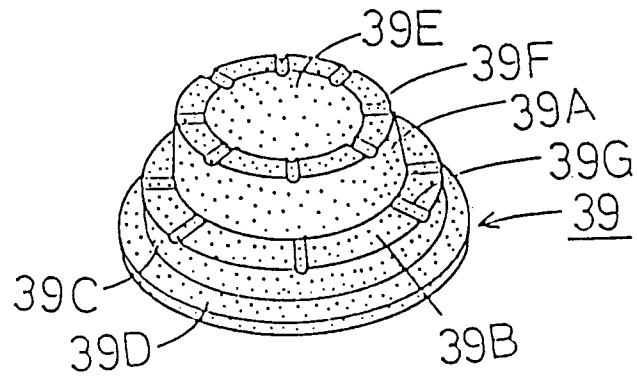

Fig. 18

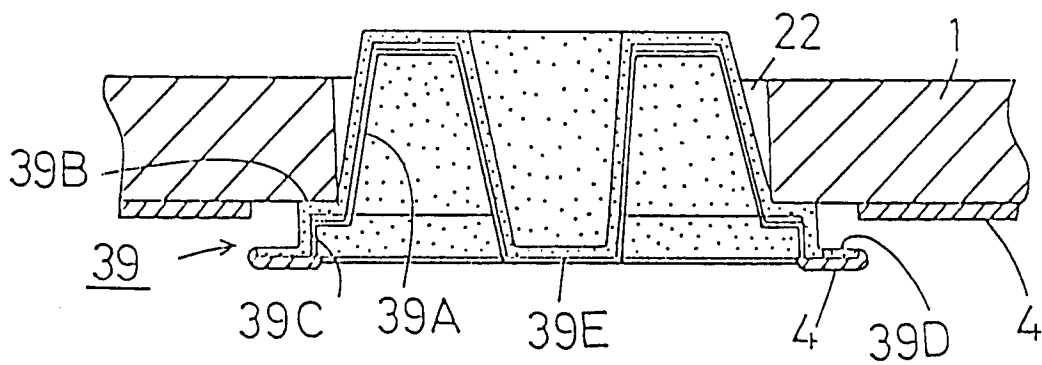

Fig. 19

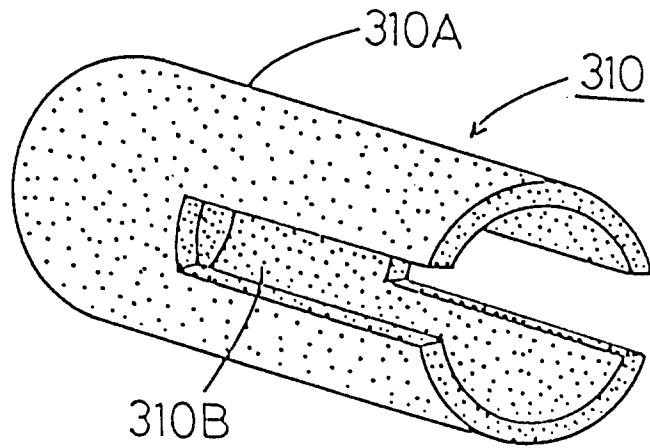

Fig. 20

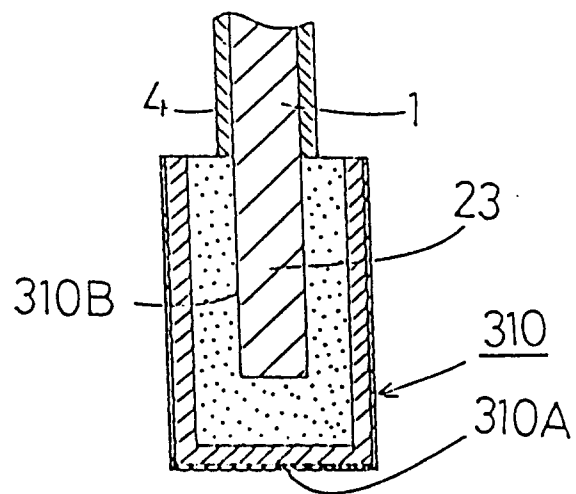

Fig. 21

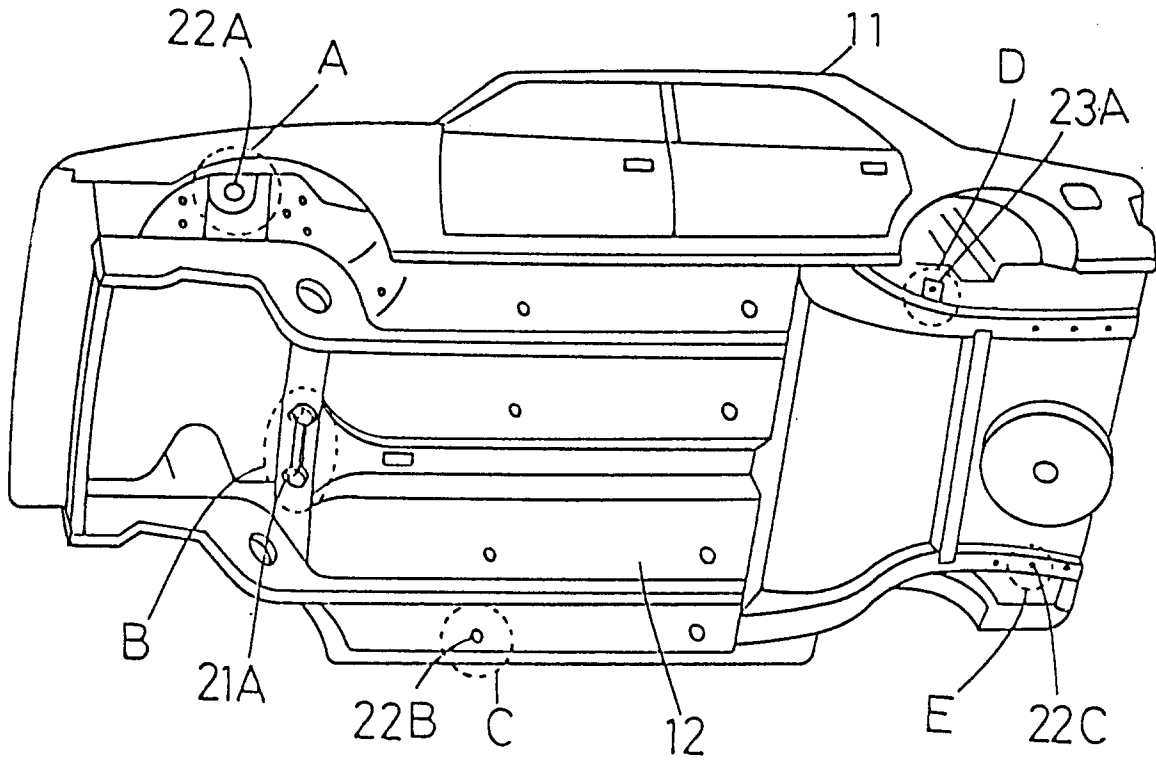

Fig. 22

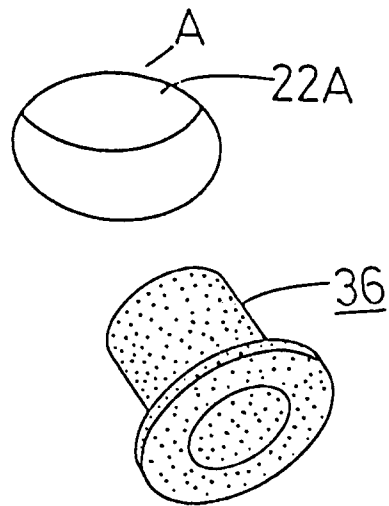

Fig. 23

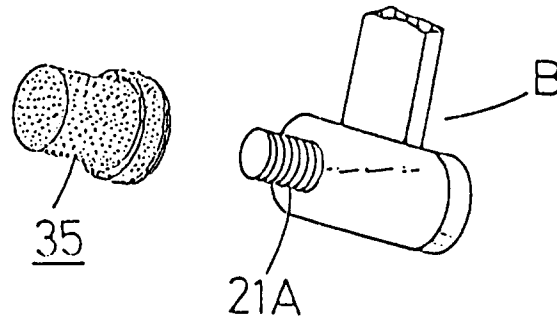

Fig. 24

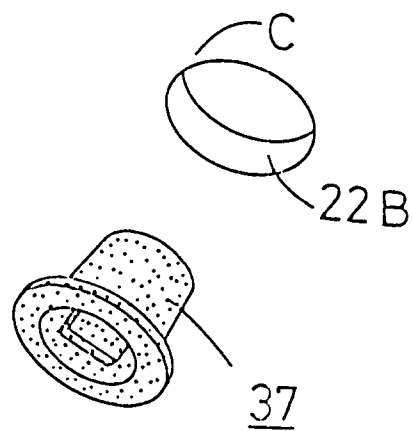

Fig. 25

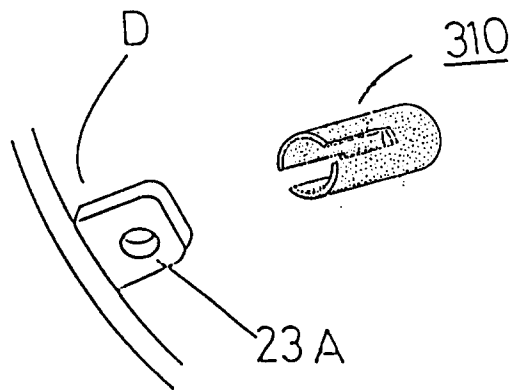

Fig. 26

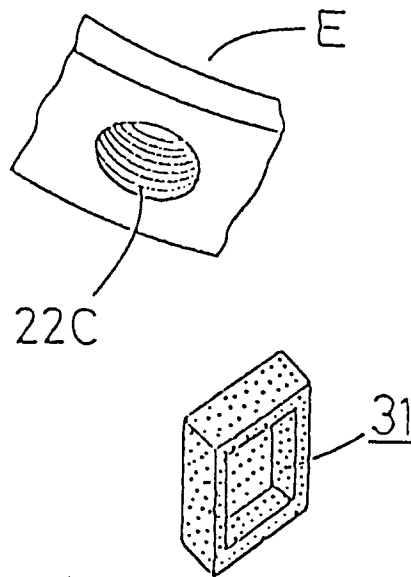

Fig. 27

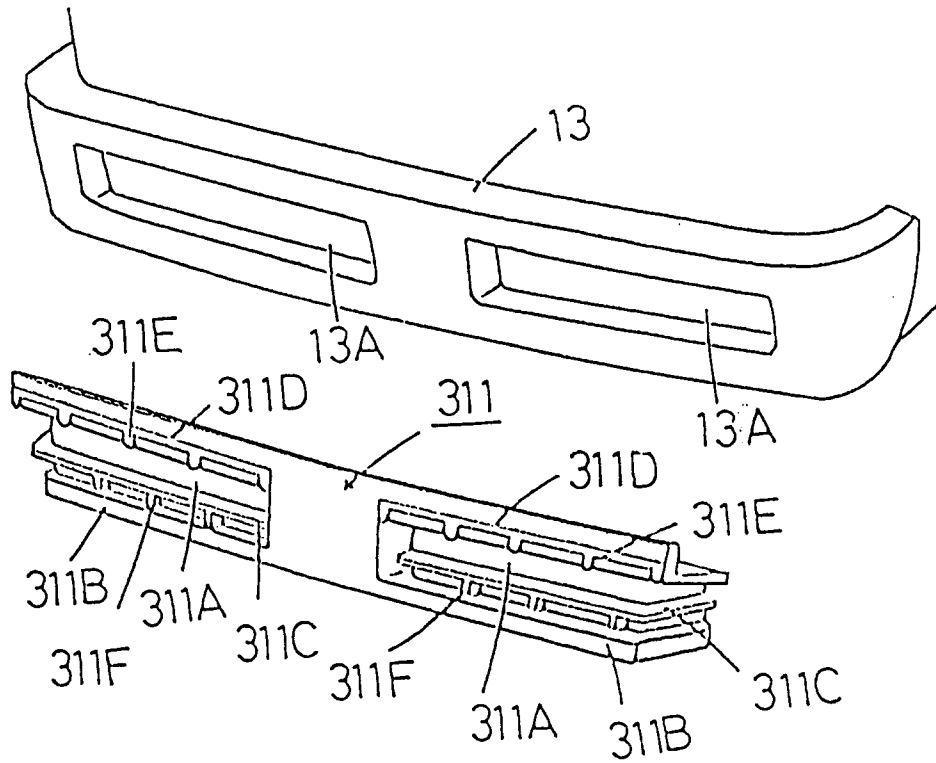

Fig. 28

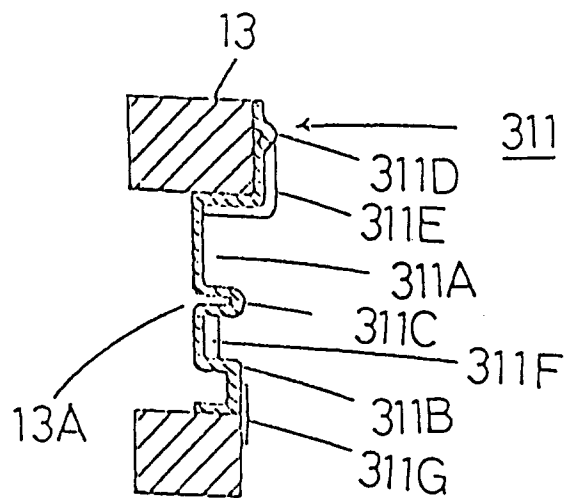

Fig. 29

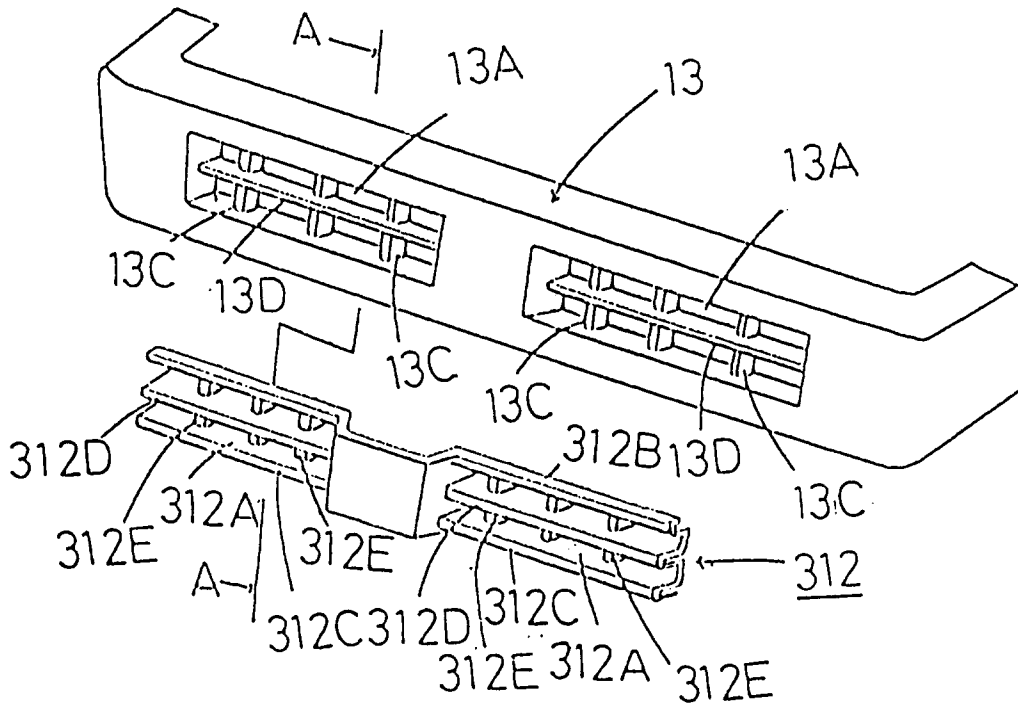

Fig. 30

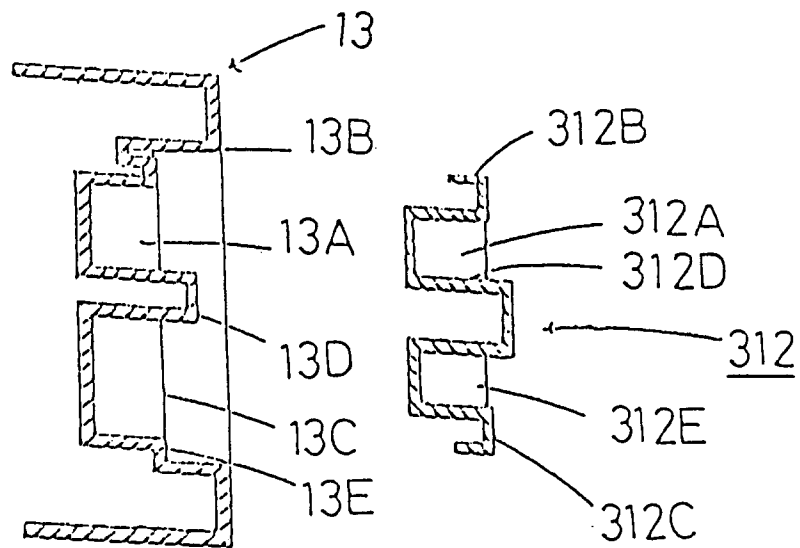

Fig. 31

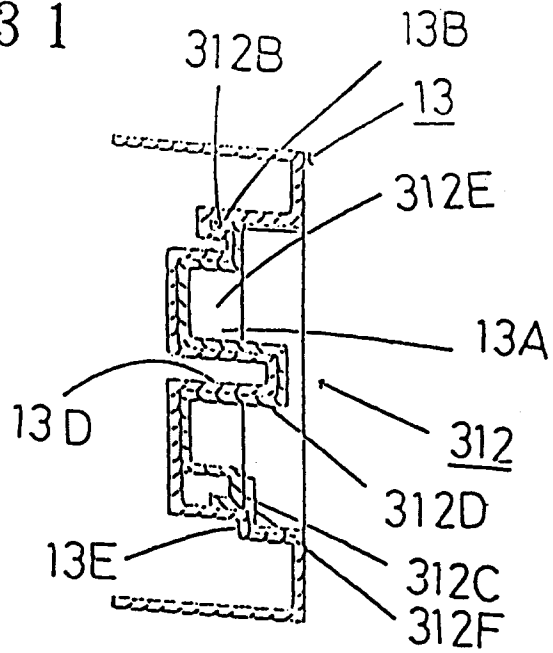

Fig. 32

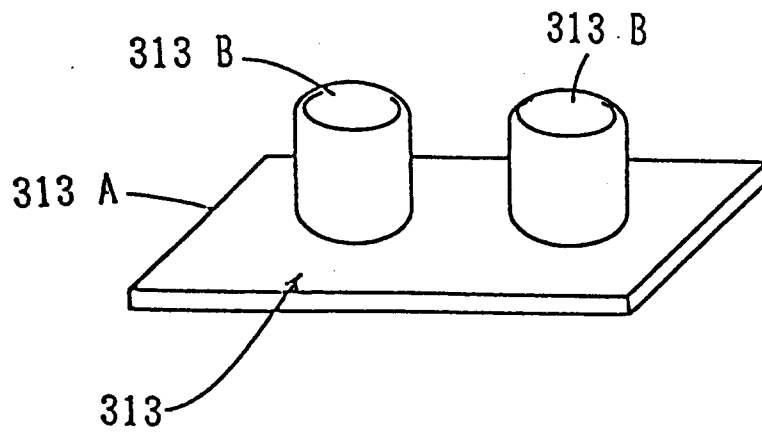

Fig. 33

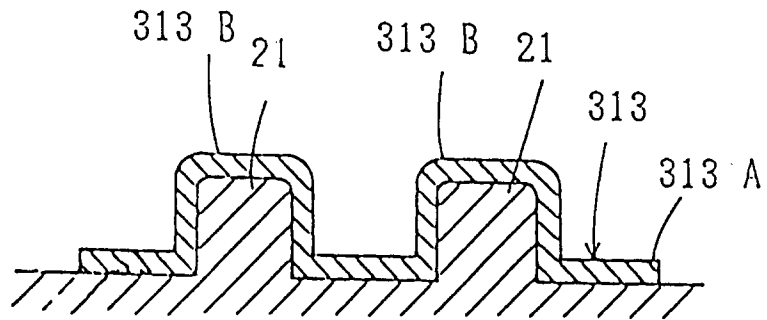

Fig. 34

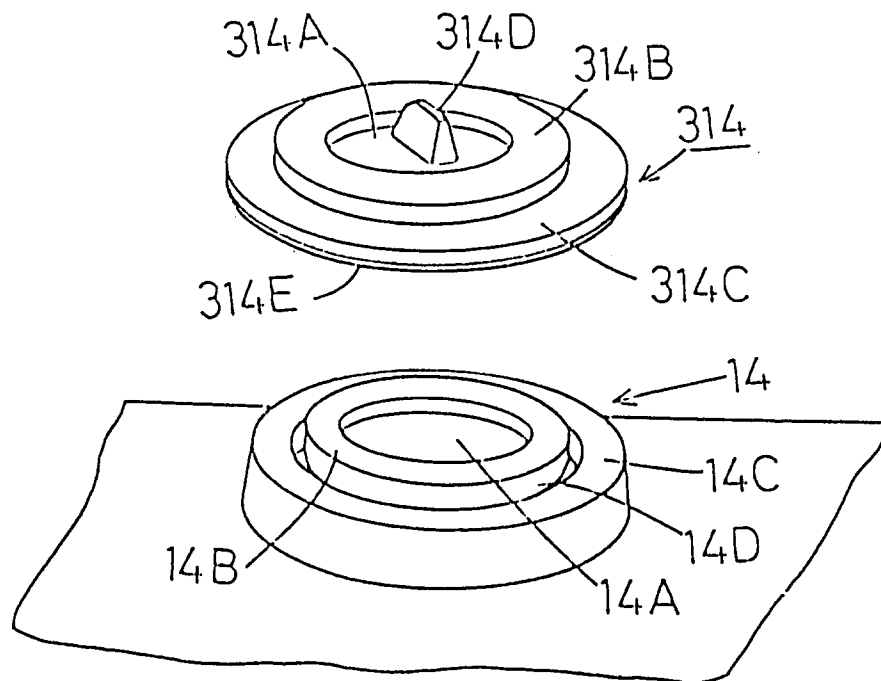

Fig. 35

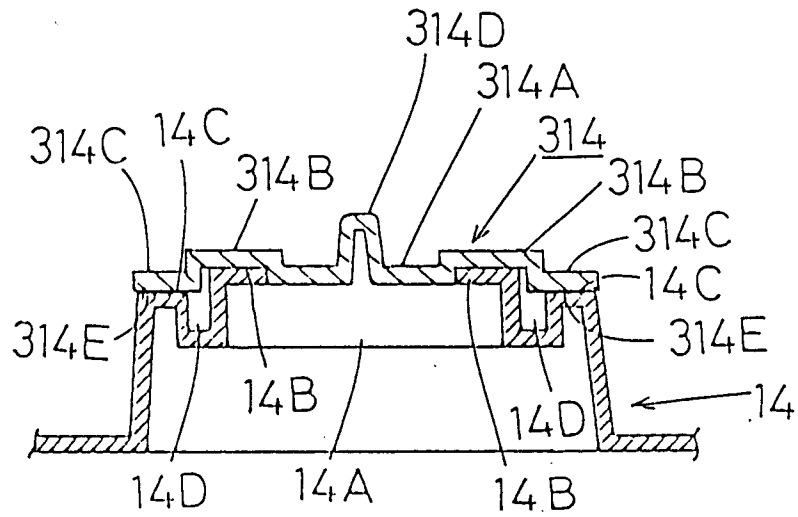

Fig. 36

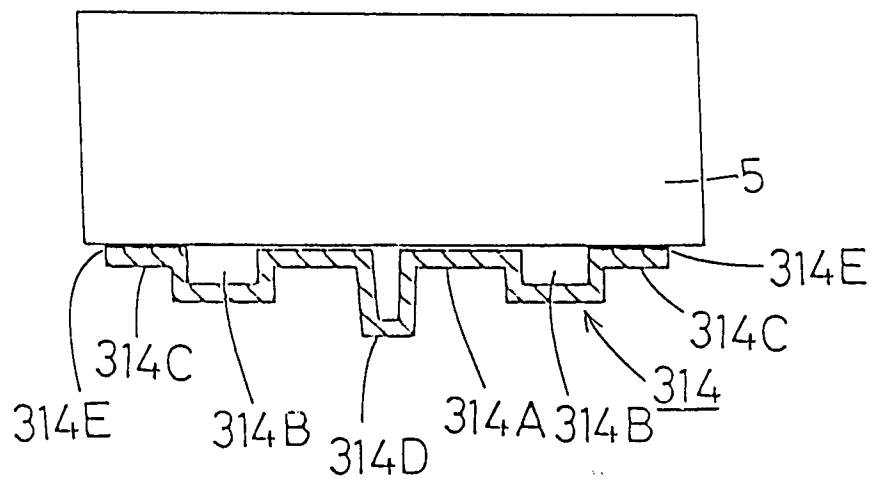

Fig. 37

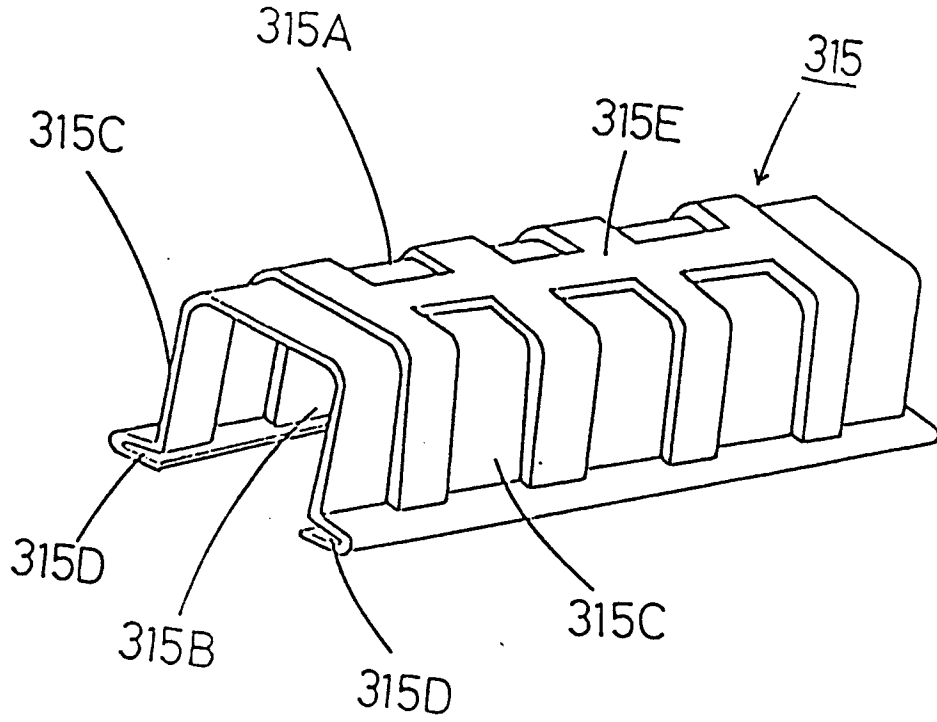

Fig. 38

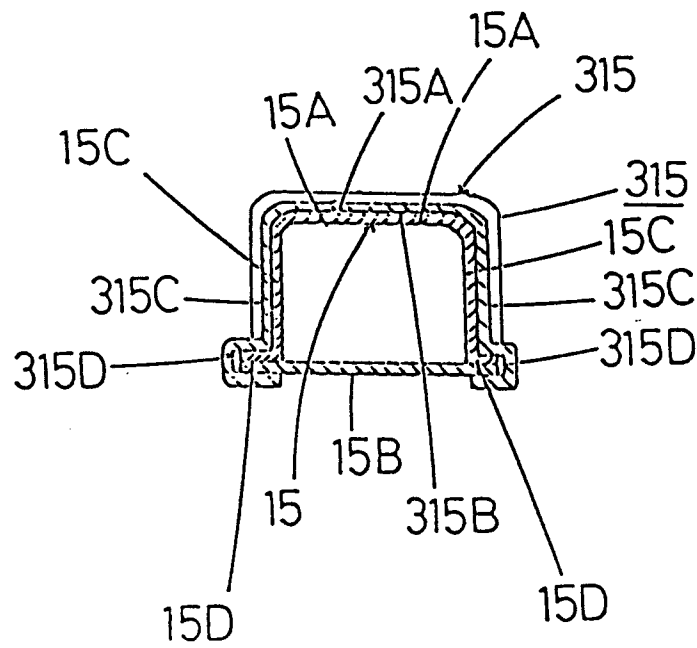

Fig. 39

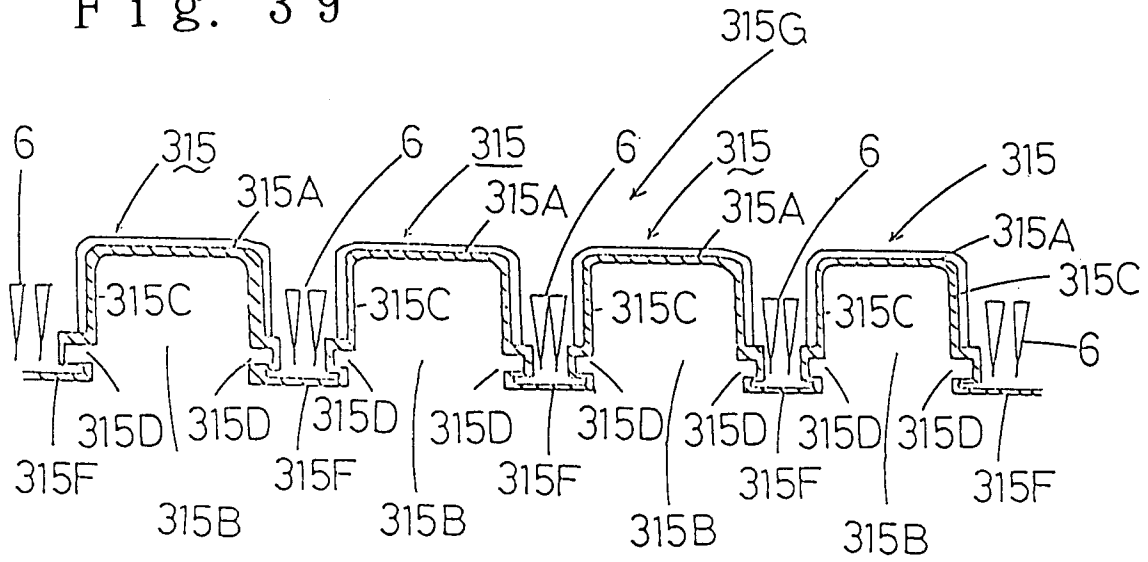

Fig. 40

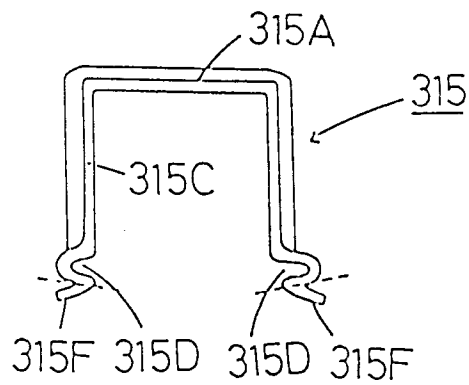

Fig. 41

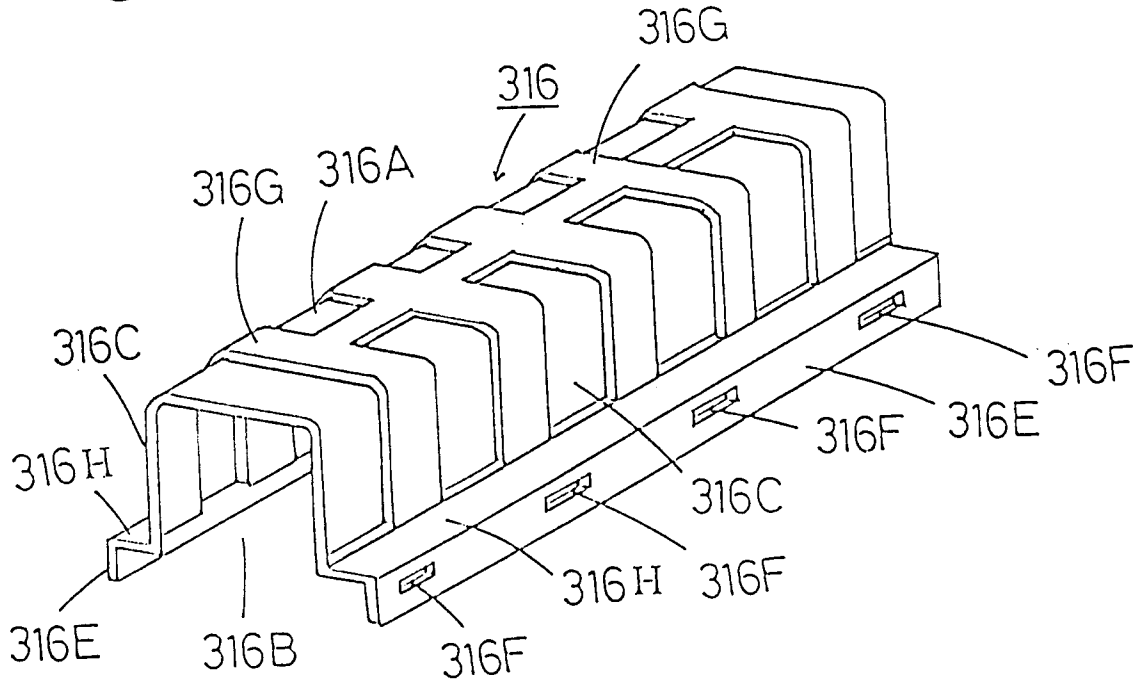

Fig. 42

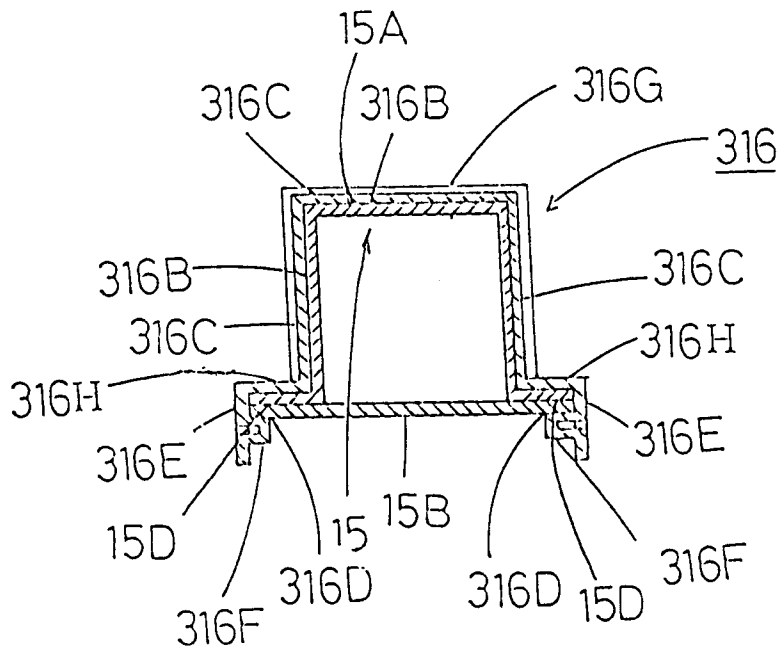

Fig. 43

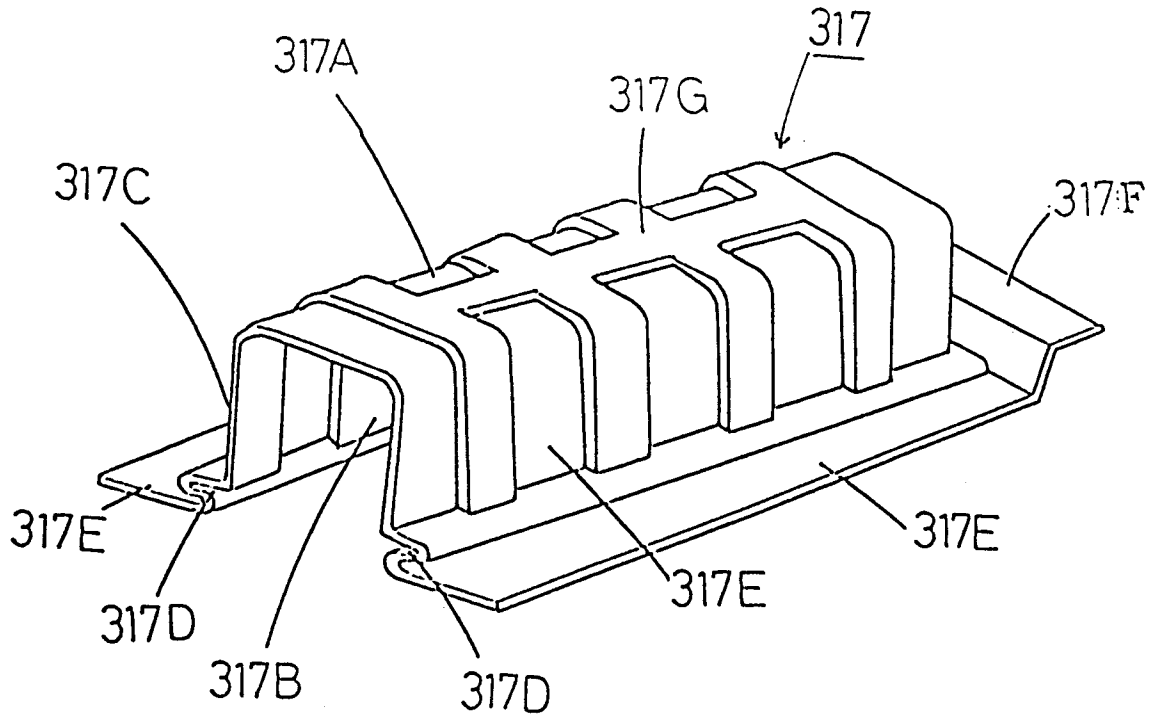

Fig. 44

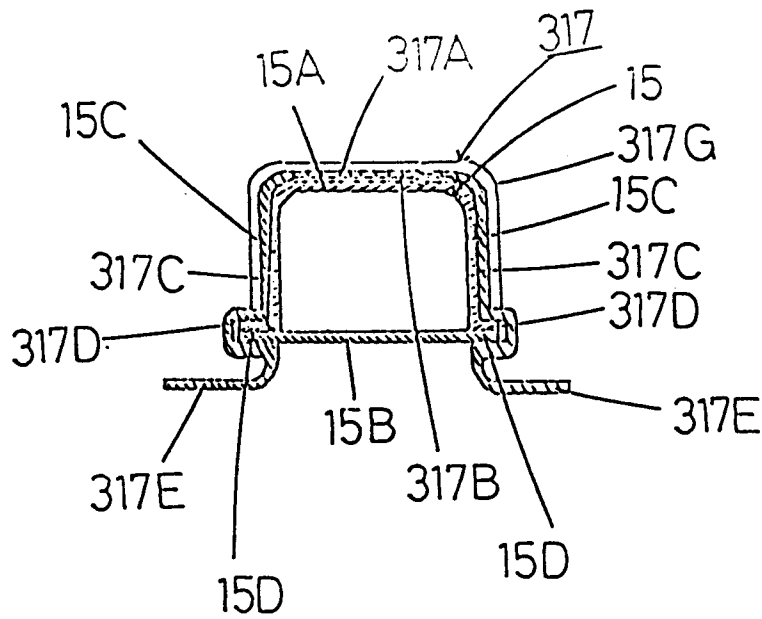

Fig. 45

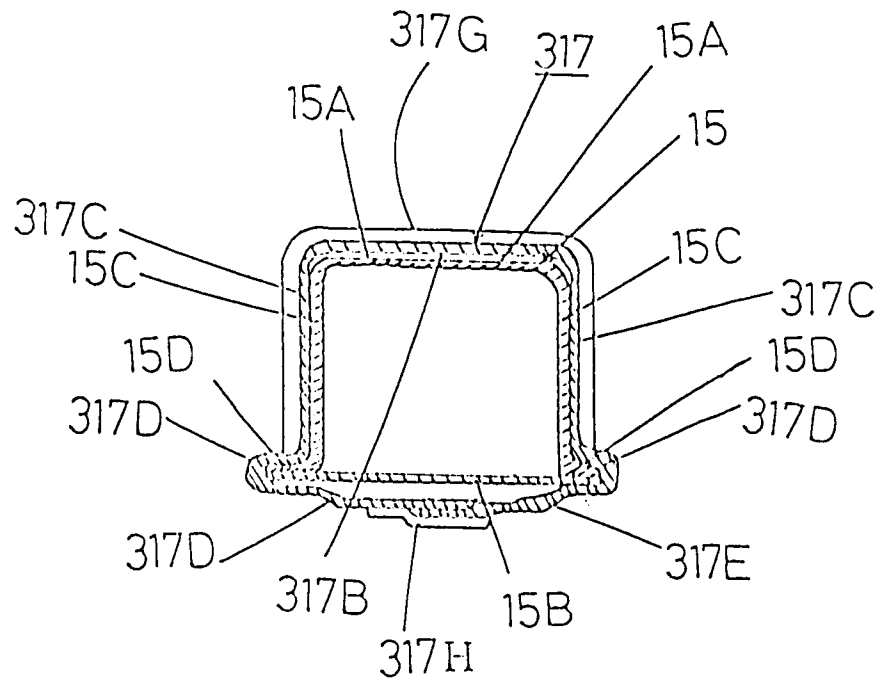
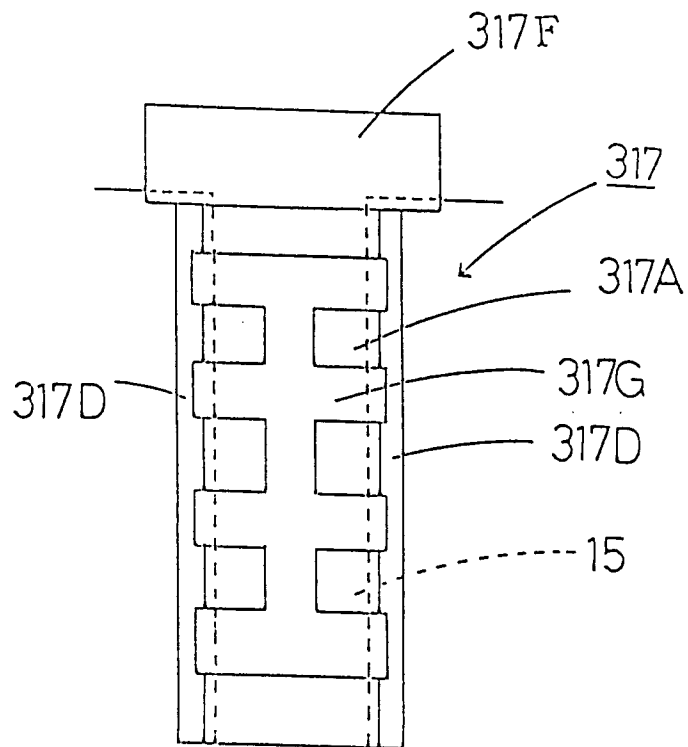

Fig. 46



INTERNATIONAL SEARCH REPORT

International application No.

PCT/JP93/01398

A. CLASSIFICATION OF SUBJECT MATTER Int. Cl ⁵ B05B15/04 According to International Patent Classification (IPC) or to both national classification and IPC	
B. FIELDS SEARCHED Minimum documentation searched (classification system followed by classification symbols) Int. Cl ⁵ B05B15/04 Documentation searched other than minimum documentation to the extent that such documents are included in the fields searched Jitsuyo Shinan Koho 1926 - 1993 Kokai Jitsuyo Shinan Koho 1971 - 1993 Electronic data base consulted during the international search (name of data base and, where practicable, search terms used)	
C. DOCUMENTS CONSIDERED TO BE RELEVANT	
Category*	Citation of document, with indication, where appropriate, of the relevant passages Relevant to claim No.
X	JP, A, 63-44958 (Hagiwara Kogyo K.K.), February 25, 1988 (25. 02. 88), Lines 9 to 17, upper right column, page 2 (Family: none) 1
X	JP, A, 61-187974 (Nippon Steel Corp.), August 21, 1986 (21. 08. 86), Claim (Family: none) 1
X	JP, A, 59-1664 (Shinko Kagaku Kogyo K.K.), January 7, 1984 (07. 01. 84), Lines 1 to 6, lower left column, page 2 (Family: none) 1
X	JP, Y2, 3-20115 (Nagoya Oilchemical Co., Ltd.), April 30, 1991 (30. 04. 91), Lines 38 to 39, column 3 (Family: none) 1
A	JP, A, 60-51567 (Nissan Motor Co., Ltd.), March 23, 1985 (23. 03. 85), Lines 1 to 5, lower left column, page 2 1
<input checked="" type="checkbox"/> Further documents are listed in the continuation of Box C. <input type="checkbox"/> See patent family annex.	
* Special categories of cited documents: "A" document defining the general state of the art which is not considered to be of particular relevance "E" earlier document but published on or after the international filing date "L" document which may throw doubts on priority claim(s) or which is cited to establish the publication date of another citation or other special reason (as specified) "O" document referring to an oral disclosure, use, exhibition or other means "P" document published prior to the international filing date but later than the priority date claimed "T" later document published after the international filing date or priority date and not in conflict with the application but cited to understand the principle or theory underlying the invention "X" document of particular relevance; the claimed invention cannot be considered novel or cannot be considered to involve an inventive step when the document is taken alone "Y" document of particular relevance; the claimed invention cannot be considered to involve an inventive step when the document is combined with one or more other such documents, such combination being obvious to a person skilled in the art "&" document member of the same patent family	
Date of the actual completion of the international search November 9, 1993 (09. 11. 93)	Date of mailing of the international search report December 7, 1993 (07. 12. 93)
Name and mailing address of the ISA/ Japanese Patent Office Facsimile No.	Authorized officer Telephone No.

INTERNATIONAL SEARCH REPORT

International application No.

PCT/JP93/01398

C (Continuation). DOCUMENTS CONSIDERED TO BE RELEVANT		
Category*	Citation of document, with indication, where appropriate, of the relevant passages	Relevant to claim No.
A	(Family: none) JP, A, 4-309583 (Dainippon Printing Co., Ltd.), November 2, 1992 (02. 11. 92), Lines 17 to 41, column 6 (Family: none)	1