

[54] **METHOD FOR ROLLING HOT METAL WORKPIECES**

[75] Inventor: **William Smith**, Burlington, Ontario, Canada

[73] Assignee: **The Steel Company of Canada Limited**, Toronto, Ontario, Canada

[22] Filed: **Nov. 13, 1972**

[21] Appl. No.: **306,013**

[30] **Foreign Application Priority Data**

Nov. 15, 1971 Great Britain..... 52995/71

[52] U.S. Cl. 72/231, 72/250

[51] Int. Cl. **B21b 1/32**

[58] Field of Search 72/146, 168, 231, 250, 72/366; 242/78, 78.7

[56] **References Cited**

UNITED STATES PATENTS

2,658,741 11/1953 Schmidt et al. 242/78
2,920,838 1/1960 Priestley 72/146

1,029,673 6/1912 Daniels 72/250
361,591 4/1887 Lenox 72/231
2,078,005 4/1937 Lloyd 72/168

Primary Examiner—Lowell A. Larson
Attorney, Agent, or Firm—Sim & McBurney

[57] **ABSTRACT**

The rolling of hot metal workpieces in a rolling mill including a reversing roughing mill stand, a finishing mill and a coiler located between the former two components is accomplished by rolling the workpiece in the roughing mill, on the third from last pass when the workpiece is between the roughing mill and the coiler rolling the workpiece to a length less than the spacing between the roughing mill and the coiler, on the last pass rolling the workpiece to a length greater than this spacing, coiling the workpiece in the coiler, uncoiling the workpiece from the coiler, delivering the workpiece to the finishing mill and rolling it in the finishing mill.

11 Claims, 13 Drawing Figures

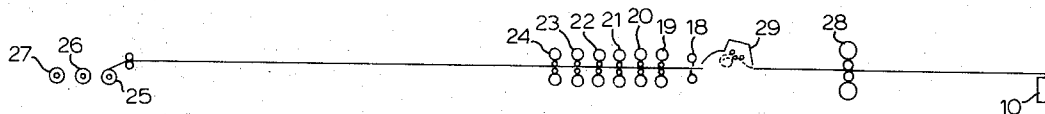

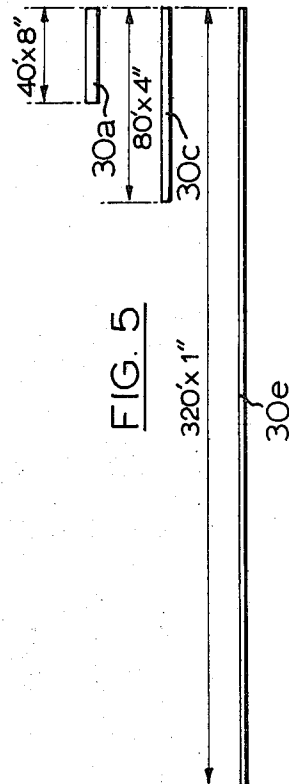
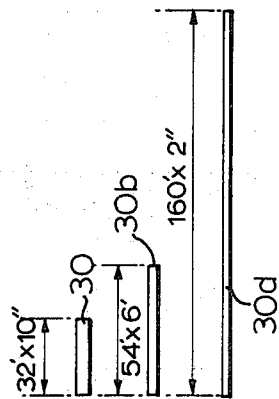
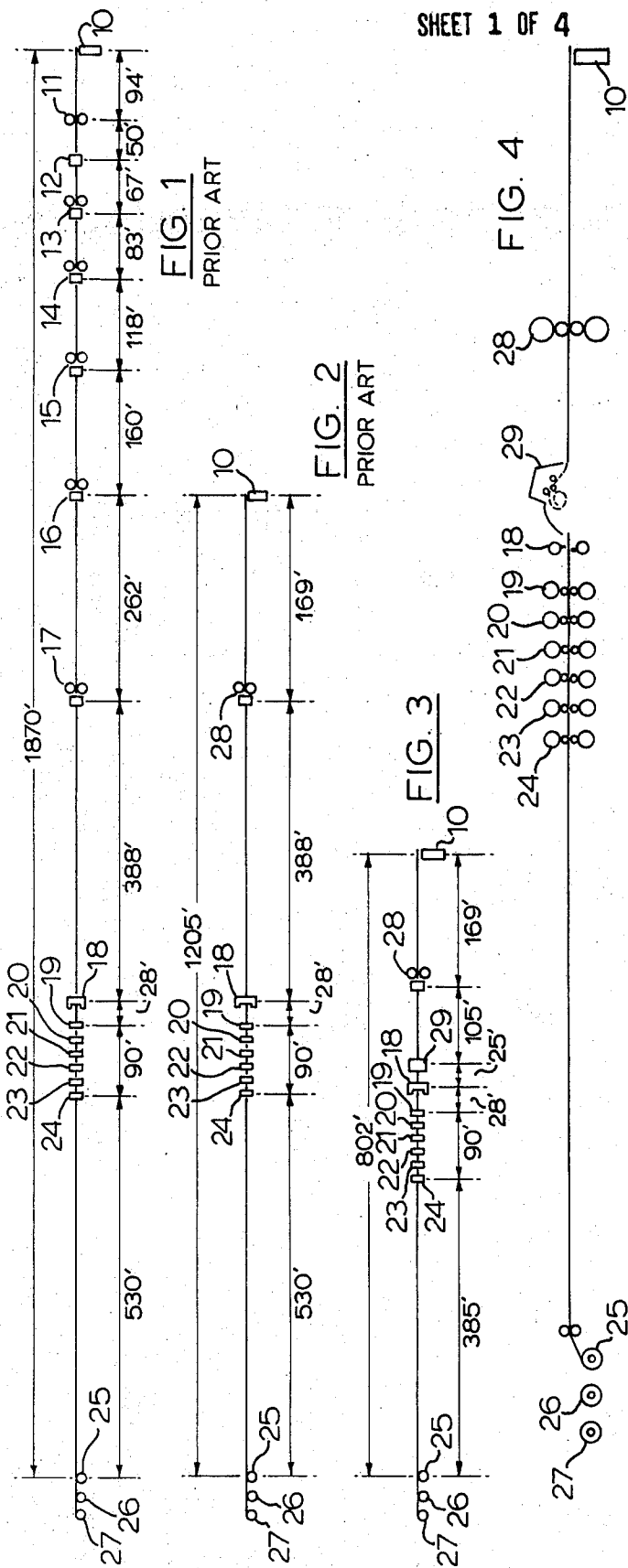

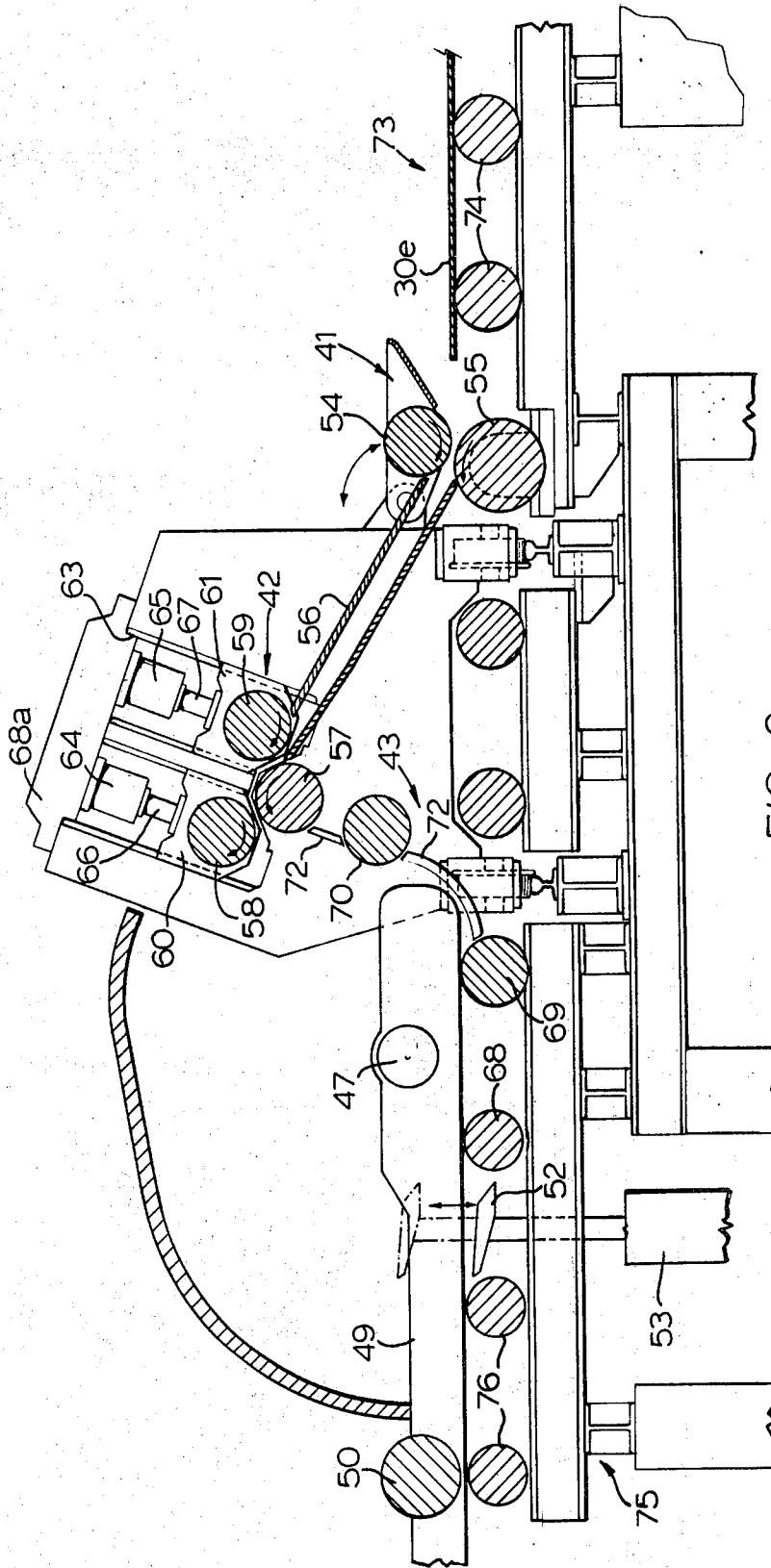

FIG. 6

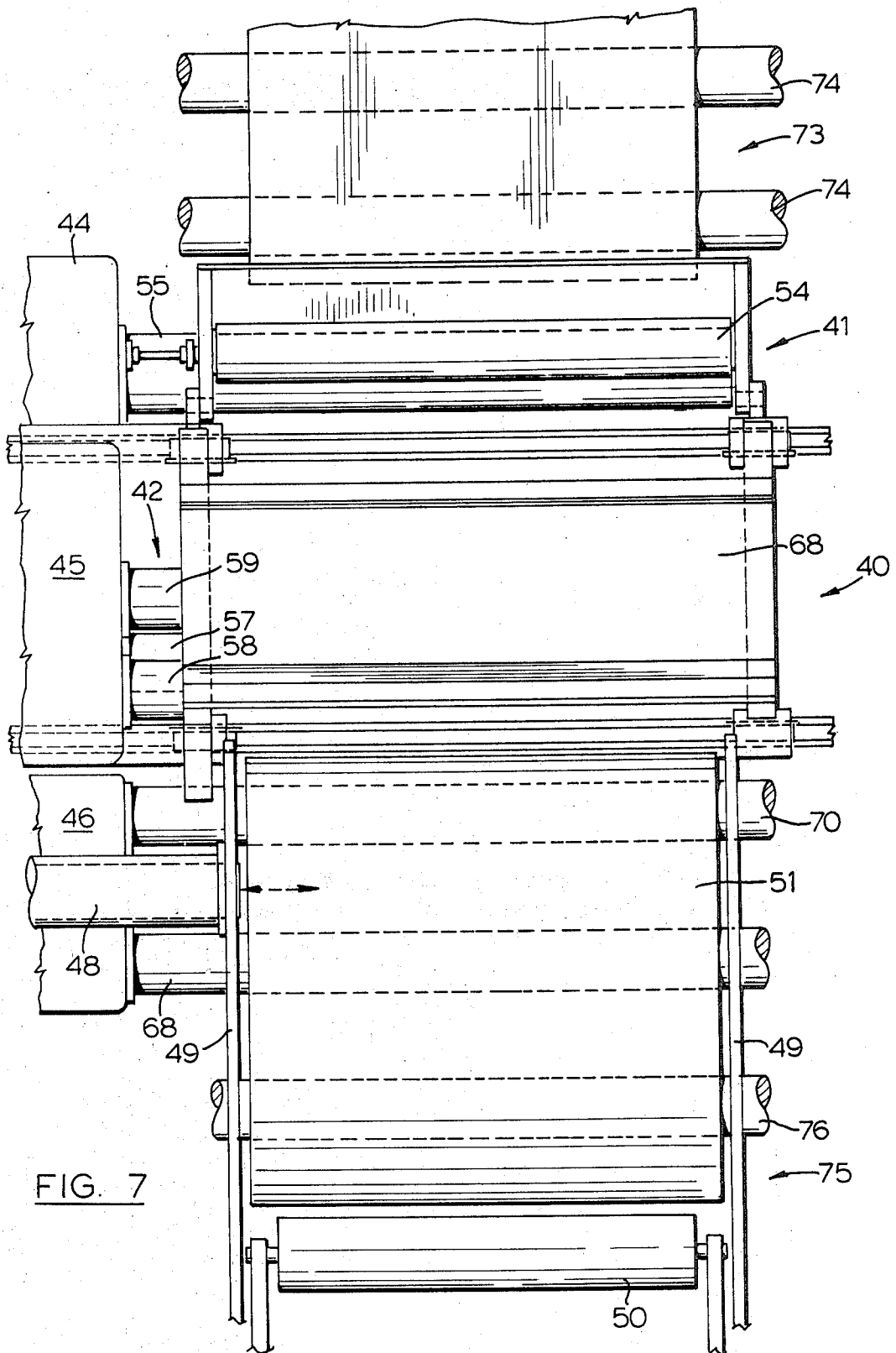

FIG. 7

SHEET 4 OF 4

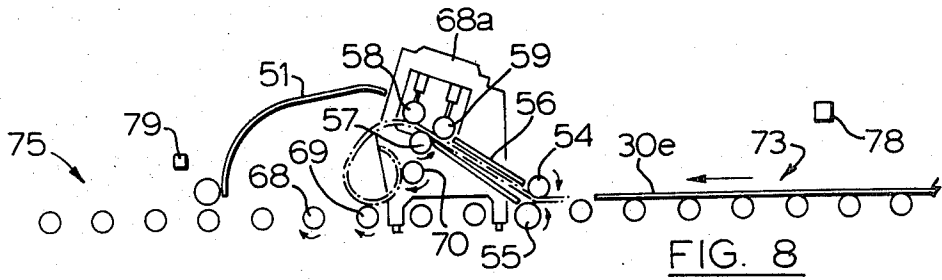

FIG. 8

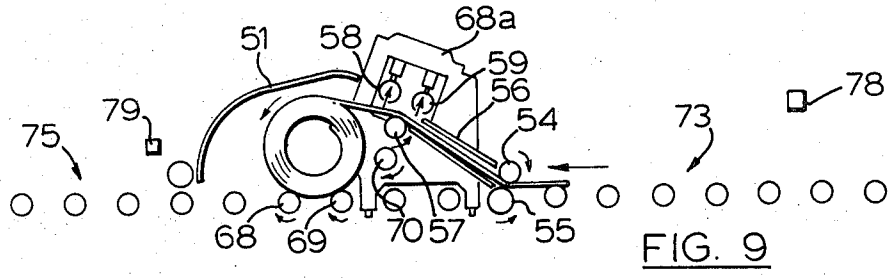

FIG. 9

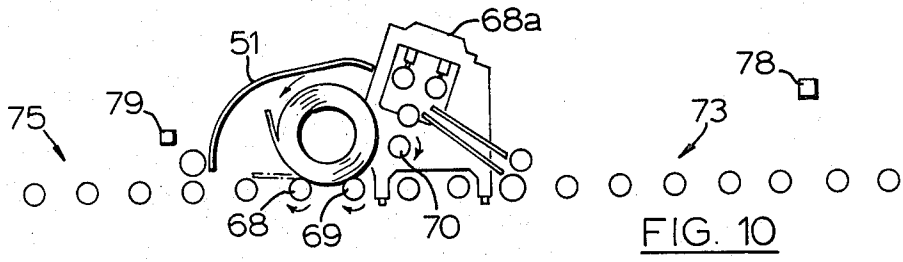

FIG. 10

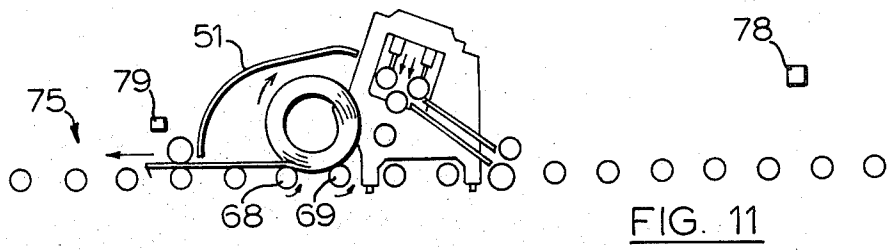

FIG. 11

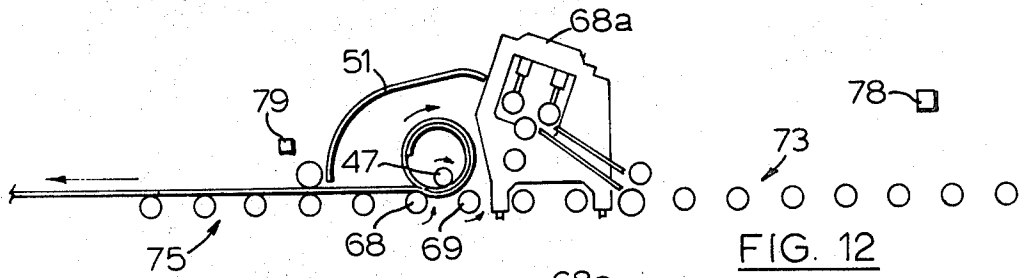

FIG. 12

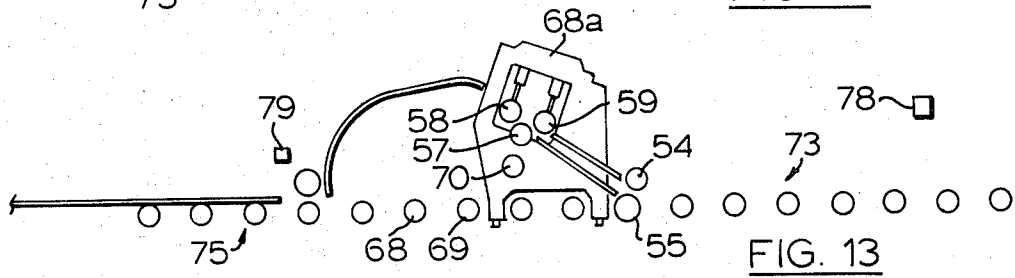

FIG. 13

METHOD FOR ROLLING HOT METAL WORKPIECES

This invention relates to methods for rolling hot metal workpieces, particularly steel, although the invention may be applied to the hot rolling of other metals, such as aluminum, for example.

In the detailed description of this invention that follows, reference will be made to the rolling and coiling of hot metal strip, specifically hot steel strip. In other words, the workpiece will be described as strip material. It is to be understood that in practicing this invention workpieces in other than strip form, for example, in rod form, may be utilized, although the invention finds particular utility where the workpiece is strip material.

The conventional method of rolling hot metal strip involves heating an ingot or slab to approximately 2,300°F (for steel) and reducing it in thickness by rolling it through a series of rolling mill stands. Normally the rolling sequence takes place in two stages referred to as the roughing mill and the finishing mill.

In the roughing mill stage the slab or ingot normally is rolled through one or more rolling mill stands in a series of passes until it is reduced in thickness to a transfer bar approximately 1 inches thick. The roughing mill stage also may include one or more vertical edging mills.

Following the roughing operation, the transfer bar normally is transferred on table rolls to a continuous finishing mill train where it is further reduced to the desired gauge.

There are a number of problems inherent in this normal method of rolling hot metal strip. Some of these problems arise from the long length of time that it takes the transfer bar to feed at a relatively slow speed into the finishing mill train. In this connection the transfer bar is fed into the finishing mill train at a speed that is slower than the speed at which the transfer bar emerges from the roughing mill. Thus, the latter speed may be 600 ft./min. and the former speed 150 ft./min. The speed of the strip emerging from the finishing mill train is much greater, of course, and may be 2,800 ft./min., for example. Another problem is that to provide sufficient future capacity it is necessary to build a mill having greater capacity than that which will be utilized initially.

Because of the high heat transfer rate of the relatively thin transfer bar, the fact that heat is imparted to the transfer bar in the finishing mill and the tail end of the transfer bar cools off as the head end thereof passes through the finishing mill train, a considerable temperature drop results between the head and tail ends of the transfer bar during the finishing mill operation. In addition, a considerable amount of secondary scale is formed on the very large exposed surface area of the transfer bar while it is waiting on the delay table ahead of the finishing mill stage. It will be understood that the aforesaid temperature differential creates a problem in that temperature is an important factor in the rolling operation, and changes in temperature must be compensated for if constant strip thickness is to be achieved. Moreover, in order to obtain constant metallurgical properties, strip temperature out of the last finishing mill stand must be kept substantially constant.

In order to overcome the temperature differential problem, modern mills are powered to roll the transfer

bar at its minimum tail end temperature, are designed for high speed operation to minimize the time that the transfer bar sits on the delay table and are equipped to provide zoom rolling in order to maintain an acceptable constant strip temperature out of the last finishing mill stand. Zoom rolling involves accelerating the finishing mill after the head end of strip has reached the coilers to compensate for the temperature differential by increasing the amount of heat put into the transfer bar during the finishing mill operation. Zoom rolling also decreases the time that the transfer bar sits on the transfer table. Where zoom rolling is used, zoom cooling also is required.

In order to remove secondary scale formed on the transfer bar while it is waiting on the delay table, a high pressure water descaling unit is employed, this unit being located just ahead of the finishing mill train. Of course, such treatment drastically reduces the temperature of the transfer bar, and additional mill rolling horsepower is required to compensate for this reduction in temperature.

It is known to provide a heat reflector shield over the delay table to reduce the heat radiation loss from the top side of the transfer bar. However, this system only partially conserves the heat of the transfer bar, does not eliminate head to tail rundown or equalize transfer bar temperature and does not prevent formation of secondary scale.

It also is known to roll a tapered transfer bar with its head end thinner than its tail end. The theory of this system is, of course, that the thicker tail end of the transfer bar will lose heat more slowly than the front end thereof and, consequently, reach the first finishing stand at a similar temperature to that of the head end when it was at the entry to the first finishing stand. This technique introduces additional operating variables, e.g., taper rolling in the roughing stands and variable drafting through the finishing stands. It also doesn't prevent formation of secondary scale.

The installation at the delay table of an induction heating furnace to control the temperature of the transfer bar has been suggested. However, this technique could interfere seriously with the removal of cobbles.

The use of a Steckel mill to avoid the aforesaid head to tail temperature differential and its associated problems also is known. A Steckel mill is designed primarily for the purpose of rolling light gauge strip on a single stand reversing hot mill. Normally there is provided a reversing roughing stand that reduces a slab to about 1 inches before presenting it to a single stand, reversing, four high roll stand with a hot coiling furnace located on either side thereof. The transfer bar is passed back and forth through the latter stand until the desired thickness is obtained, the strip being successively reheated in the coiling furnaces on the final passes. This method suffers from the following drawbacks:

- a. poor strip surface quality resulting from the formation of scale during the rolling and reheating cycles, this scale being rolled into the strip,
- b. fast deterioration of mill work rolls caused by rolled in scale and all work being done on one set of mill rolls, and
- c. variation in gauge due to the ends of the strip being colder than the middle of the strip because of the relatively cool temperature of the mandrels and the length of time that the ends of the strip are out of

the hot coiling furnaces during the reversing cycle. In accordance with this invention, methods are provided for rolling hot metal workpieces that offer the important advantage of, for a new mill, reducing the length of the mill, buildings, foundations etc. that would otherwise be required and providing flexible capacity to take care of future requirements or, for an existing mill, increasing the capacity of the mill to roll larger size coils than it was designed to roll. Other significant advantages that may be obtained are as follows:

- a. conservation of the heat of the hot metal workpiece,
- b. substantial equalization of the temperature of the hot metal workpiece,
- c. reduction in the formation of secondary scale on the hot metal workpiece, and
- d. reduction in the cost of mill drives, electric motors, power supplies, controls and other electrical equipment.

In accordance with a method embodying this invention, the rolling of hot metal workpieces in a rolling mill of the type that includes a roughing mill comprising a reversing roughing mill stand, a finishing mill comprising at least one finishing mill stand and coiler means located between the roughing and finishing mills for coiling a hot metal workpiece delivered thereto from the roughing mill before the hot metal workpiece is rolled in the finishing mill is accomplished utilizing the following steps:

- a. delivering the workpiece to the roughing mill;
- b. rolling the workpiece in the roughing mill by passing it back and forth through the reversing roughing mill stand in a series of passes — on the third last pass, passing the workpiece from a first side of the reversing roughing mill stand further from the coiler to the second side thereof closest to the coiler and rolling the workpiece to a length less than the spacing between the reversing roughing mill stand and the coiler — on the last pass of the workpiece through the reversing roughing mill stand again passing the workpiece from the first side to the second side of the reversing roughing mill stand, but rolling the workpiece to a length greater than the spacing between the reversing roughing mill stand and the coiler;
- c. coiling the workpiece from the roughing mill in the coiler;
- d. thereafter uncoiling the workpiece from the coiler;
- e. subsequently delivering the workpiece to the finishing mill; and
- f. rolling the workpiece in the finishing mill.

This invention will be more apparent from the following detailed description, taken in conjunction with the appended drawings, in which:

FIG. 1 is a schematic top elevation of a conventional, fully continuous hot strip mill;

FIG. 2 is a schematic top elevation of a conventional semi-continuous hot strip mill;

FIGS. 3 and 4 are schematic top and side elevations respectively of a semi-continuous hot strip mill constituting a preferred embodiment of this invention;

FIG. 5 is a diagram showing the relative lengths and thicknesses of a slab and transfer bar processed in the apparatus of FIGS. 3 and 4;

FIG. 6 is a side elevation, partly in section, of a coiler that may be used in practicing this invention;

FIG. 7 is a top elevation of the coiler shown in FIG. 6; and

FIGS. 8-13 are schematic side elevations of the coiler shown in FIG. 6 at various stages during its operation.

Referring to the conventional, fully continuous hot strip mill of FIG. 1, it includes, in the following order, a furnace 10, a vertical scale breaker 11, a horizontal scale breaker 12, a roughing mill consisting of five roughing mill stands 13, 14, 15, 16 and 17 each with its own vertical edger, a rotary crop shear 18, a finishing mill consisting of six finishing mill stands 19, 20, 21, 22, 23 and 24 and three coilers 25, 26 and 27. Indicated in FIG. 1 are typical distances in feet between various components of the rolling mill assuming that it is arranged to roll 1,000 pounds per inch of width (P.I.W.) steel strip.

The conventional, semi-continuous hot strip mill of FIG. 2 also is arranged to roll 1,000 P.I.W. strip and differs from the hot strip mill of FIG. 1 in that its roughing mill consists of a single reversing roughing mill stand 28 rather than direct rolling roughing mill stands 13-17. Similar components in the two Figures (and in FIGS. 3 and 4) are identified by the same reference numerals.

It will be apparent that utilization of the mill of FIG. 2 results in a considerable saving in real estate, foundations, mill buildings, roller tables etc. over the mill of FIG. 1, since there is a difference in length of 665 feet between them.

FIGS. 3 and 4 illustrate a preferred embodiment of this invention and show a semi-continuous hot strip mill also arranged to roll 1,000 P.I.W. strip. It differs from the mill of FIG. 2 in that it includes a coiler 29 located between reversing roughing mill stand 28 and the first finishing mill stand 19. More specifically, coiler 29 is located between reversing roughing mill stand 28 and rotary crop shear 18. Not shown but part of the hot strip mill is the runout table on which the strip passes from the finishing mill to the coilers 25, 26 and 27, the water sprays above the runout table, other roller tables between various components and a descaling spray unit that may be located between crop shear 18 and finishing mill stand 19, all of which are conventional. It also should be understood that the number and type of stands that constitute the finishing mill, the type, location and even provision of a crop shear, and the number and type of coilers 25-27 are not material to this invention.

A number of different types of coilers may be used for coiler 29. Preferably, however, coiler 29 is of a type that accepts the hot metal strip from reversing roughing mill stand 28 head end first, coils the hot metal strip and then delivers it tail end first to the finishing mill. Coiler 29 also preferably is a mandrelless coiler, since a coiler of this type offers a number of advantages which will become more apparent hereinafter. A mandrelless coiler that may be used in methods embodying this invention is illustrated in FIGS. 6 and 7 and will be described in greater detail hereinafter. In fact this mandrelless coiler is a mandrelless downcoiler, but it might also be an upcoiler.

The operation of the apparatus shown in FIGS. 3 and 4 and a preferred method embodying this invention

now will be described with reference to FIGS. 3 and 4 as well as to FIG. 5.

A slug or ingot 30 (FIG. 5) from furnace 10 is delivered to reversing roughing mill stand 28 on a suitable roller table (not shown) and is rolled in reversing roughing mill stand 28 to the desired thickness. This is achieved by passing the hot metal workpiece or transfer bar back and forth through the reversing roughing mill stand in a series of passes from one side thereof to the other side thereof and vice-versa. In the embodiment of the invention illustrated, the transfer bar is passed through the reversing roughing mill stand five times: Referring to FIG. 5, the slab 30 delivered from furnace 10 to reversing roughing mill stand 28 may have a length of 32 feet and a thickness of 10 inches. The length and thickness of the slab changes as it is passed through reversing roughing mill stand 28, and the changes in dimension are illustrated in FIG. 5, the various transfer bars after each pass being designated 30a, 30b, 30c, 30d and 30e. It will be seen that on the third last pass of the transfer bar through reversing roughing mill stand 28, the transfer bar is passed from the side of reversing roughing mill stand 28 further from coiler 29 to the side thereof closer to coiler 29 and is lengthened from 54 ft. to 80 ft., its thickness being correspondingly diminished. It will be seen from FIG. 3 that the distance between reversing roughing mill stand 28 and coiler 29 is slightly greater than 80 ft. It is important that on this third last pass the transfer bar be rolled to a length that is less than the spacing between reversing roughing mill stand 28 and coiler 29, since entry of the transfer bar into coiler 29 is not desired on this particular pass. On the second last pass through reversing roughing mill stand 28, the transfer bar is further lengthened from 80 ft. to 160 ft. and its thickness correspondingly reduced. On the last pass through reversing roughing mill stand 28, the transfer bar again is passed from the side of reversing roughing mill stand 28 further from coiler 29 to the side thereof closer to coiler 29 but, unlike the third last pass, is rolled to a length that is considerably greater than the spacing between reversing rolling mill stand 28 and coiler 29. In the example shown, the transfer bar is rolled to a length of 320 ft., whereas the spacing between reversing roughing mill stand 28 and coiler 29 is 105 ft.

In the conventional, semi-continuous hot strip mill shown in FIG. 2, the distance between reversing roughing mill stand 28 and crop shear 18 must be sufficient to accommodate the transfer bar designated 30e in FIG. 5, and it is for this reason that there is a spacing between reversing roughing mill stand 28 and crop shear 18 in FIG. 2 of in excess of 320 ft. A spacing in excess of 320 ft. also must exist between rolling mill stand 17 and crop shear 18 in the conventional, fully-continuous hot strip mill of FIG. 1. However, the interposition of coiler 29 between reversing roughing mill stand 28 and crop shear 18 or between the former and finishing mill stand 19 makes it entirely unnecessary to provide sufficient space between reversing roughing mill stand 28 and crop shear 18 or between the former and finishing mill stand 19 to accommodate the full length of transfer bar 30e. Consequently, there is a marked reduction, as compared with the hot strip mills of FIGS. 1 and 2, in the spacing between furnace 10 and crop shear 18 or in the spacing between furnace 10 and finishing mill stand 19. This represents not only a

saving in real estate, but also a saving in mill buildings, foundations and roller tables. In order to maximize these savings, transfer bar 30e should be as long as possible consistent with transfer bar 30c being of a length less than the spacing between reversing roughing mill stand 28 and coiler 29. Preferably transfer bar 30e is considerably longer than the distance between reversing roughing mill stand 28 and crop shear 18 and, even more preferably, is considerably longer than the spacing between reversing roughing mill stand 28 and finishing mill stand 19.

Transfer bar 30e is delivered on a suitable roller table (not shown) head end first to coiler 29, and the complete transfer bar is coiled therein. This step is as opposed to the step utilized in the operation of the mills of FIGS. 1 and 2 wherein the transfer bar would be delivered from the roughing mill to a delay table and remain thereon until delivered to the finishing mill, with all the attendant disadvantages that flow from this prior art procedure.

After transfer bar 30e has been completely coiled in coiler 29, it is uncoiled and delivered on a roller table (not shown), preferably tail end first, to the finishing mill. The detailed operation of a mandrelless down-coiler that may be used for coiler 29 will be described hereinafter. Before the transfer bar is delivered to the finishing mill, it passes through crop shear 18 that crops the end of the transfer bar in a conventional manner. The transfer bar then is rolled in the finishing mill in a conventional manner and delivered on a runout table (not shown) to and coiled by one of coilers 25, 26 and 27. As noted beforehand, a descaling unit may be provided between crop shear 18 and finishing mill stand 19 and water sprays for cooling the transfer bar are provided over the runout table.

Provision may be made, if desired, to permit coiler 29 to be readily removed, thereby converting the hot strip mill of FIGS. 3 and 4 to a direct rolling mill, albeit of limited capacity.

The use of coiler 29 and the rolling technique hereinbefore described enables the length of the transfer table between the roughing and finishing stands to be reduced appreciably. Thus, with a mill designed to roll 1,000 P.I.W., it may be possible to reduce the length of the transfer table by about 250 feet or 260 feet, resulting in a considerable capital cost saving.

Another significant advantage of the method constituting this invention can be seen by comparing the lengths of the runout tables in FIGS. 1-4, this length being the distance between the last finishing mill stand 24 and the first coiler 25. For a conventional, fully continuous hot strip mill (FIG. 1) and a conventional, semi-continuous hot strip mill (FIG. 2), the runout tables are 530 feet in length. By way of comparison, the runout table in FIGS. 3 and 4 is only 385 feet, a difference of 145 feet. This reduction in the length of the runout table results from the fact that zoom rolling is not required when coiler 29 is employed.

In conventional, hot strip mills the transfer bar is accelerated considerably as it passes through the finishing mill stands (so called zoom rolling) to compensate for the head-to-tail temperature rundown of the transfer bar. An extremely important feature in the development of proper metallurgical properties in the strip emerging from the finishing mill is the cooling which takes place between the last finishing mill stand 24 and the coiler and, consequently, the temperature at which

the strip is coiled. In conventional, hot strip mills the transfer bar is accelerated during passage through the finishing mill, so the runout table must be sufficiently long to allow adequate cooling of the strip exiting from the finishing mill at very high speed (up to 4,000 feet per minute). However, in a method embodying this invention as described hereinbefore, the transfer bar can be rolled in the finishing mill at more moderate, constant speeds of, say, about 2,500 feet per minute and achieve similar rolling rates. Consequently, the length of the runout table can be considerably shorter and yet still provide the necessary degree of cooling for the entire length of rolled strip.

It should be understood that this invention may be practised with an existing, conventional semi-continuous hot strip mill of the type shown in FIG. 2. Since such a hot strip mill is an existing mill, no saving in real estate, mill buildings, foundation, roller tables etc. will be realized, but, on the other hand, the capacity of the mill can be suitably increased by virtue of its ability to accommodate a transfer bar on the final pass through reversing roughing mill stand 28 that is considerably longer than the transfer bar that can be accommodated without the provision of coiler 29.

A mill designed and powered for rolling the bulk of the product mix, e.g. 62 inches wide, 0.09 inches thick \times 750 P.I.W., in a conventional manner could, by the practise of the method hereinbefore described, roll a wider range of product, possibly 74 inches wide, 0.06 inches thick \times 1,000 P.I.W., the coiler in the latter case providing the temperature equalizing and heat retention required in order to remain within the power capability of the mill and metallurgical property limits of the product.

Since transfer bar 30e stored in coil form in coiler 29 goes through a temperature equalizing cycle, and it can be arranged so that there is negligible heat loss to the atmosphere, the temperature of transfer bar 30e entering the first finishing mill stand 19 can be substantially constant head to tail, and the transfer bar then can be fed into the finishing mill train at a slower speed, so that more power can be used for rolling materials like stainless steel or high strength low alloy steels.

Since the head to tail temperature of transfer bar 30e entering the first finishing mill stand 19 can be substantially constant, zoom rolling and its attendant complications conventionally required to compensate for head to tail temperature rundown can be avoided, as aforementioned. Ancillary to this, there is no necessity to accelerate gradually from, say, 2,000 ft./min. to 4,000 ft./min., as is necessary when zoom rolling is practised. Consequently, after the strip has reached the coilers 25, 26 or 27, the finishing mill stands can be accelerated to top speed at a very fast rate and produce at a higher rolling rate. Moreover, with zoom rolling eliminated, the strip can travel at a constant speed between the last finishing mill stand 24 and the coilers, simplifying the runout cooling spray system (no zoom cooling), and yet identical metallurgical properties can be obtained throughout the coil.

Since the finishing mill stands will roll a constant temperature transfer bar at a constant speed, thus removing these two variables, more stable mill operation should result, the work of the automatic gauge control (A.G.C.) system and loopers should be reduced and closer product tolerances achieved.

Since the temperature of transfer bar 30e entering the first finishing mill stand 19 can be predetermined and will remain substantially constant regardless of thickness or coil size, it should be possible to roll high tensile alloy steels by reducing mill speed and hence increasing mill power and taking minor productivity penalties. The reduction in rolling speed also will eliminate the need for high powered coilers and possibly could permit the use of in-line flying shears in place of coilers and also reduce the fumes normally produced on the last three finishing mill stands of a conventional high speed mill.

If a staged capacity hot strip mill is desired, it is possible to start with a four finishing mill stand installation by reducing the transfer bar thickness in the roughing mill to something less than 1 inches. This will enable the final coiler 25, 26 or 27 to be located closer initially to the finishing mill, reducing the length of the runout table, building foundations, etc.

In a conventional, hot strip mill any cobbles at the finishing mill or coilers usually mean the loss of the following transfer bar being rolled simultaneously at the roughing mill, since it would be too cold for further processing after the cobble has been cleared. With the mill of FIGS. 3 and 4, the roughing mill could complete its operation and hot transfer bar 30e could be stored in coiler 29 until the cobble was cleared. In a conventional, hot strip mill transfer bar 30e may come into the first finishing mill stand at the relatively high temperature of about 1950°F - 2,000°F to compensate for the head to tail temperature drop during finishing mill rolling, and this high temperature results in substantial scale formation. With a mill of the type shown in FIGS. 3 and 4, the development of secondary scale through the finishing mill stands can be controlled by predetermining the transfer bar temperature at its time of entry into the finishing mill and keeping it below the temperature at which high temperature secondary scale forms.

While in furnace 10, slabs 30 are on skids which create cold spots in the slabs. Operation of the A.G.C. system is required to reduce the thickness of these cold spots. In a mill of the type shown in FIGS. 3 and 4, it may be possible to substantially temperature equalize the cold spots.

In conventional, hot strip mills there is a minimum temperature for the slabs delivered from the furnace to ensure proper transfer bar temperature at the finishing mill. With the temperature equalizing effect that can result from the practise of a method embodying this invention, this minimum temperature can be reduced and the slabs moved through the furnace more quickly.

The practice of the method hereinbefore described will reduce the temperature loss in the transfer bar significantly, and this will result in a substantial increase of P.I.W. on an existing mill.

By the practice of the aforesaid method, it is believed possible that a mill layout designed for conventional rolling of 750 P.I.W. could roll up to, say, 1,600 P.I.W.. This would enable a reheating furnace to be charged with slabs all of the same length and thickness to give 100 percent furnace hearth utilization. The hot transfer bar then would be split into desired sizes at a crop shear ahead of the first finishing mill stand.

Many different types of coilers having mandrels have been designed and used for coiling hot transfer bars. The primary disadvantages of mandrel type coilers are

that the mandrel tends to scratch the hot transfer bar, and scale is picked up by the hot transfer bar from the mandrel. In addition, the temperature differential between the mandrel (generally at 1,600°F. or less) and the hot transfer bar (at about 1950°F.) causes the end of the bar adjacent the mandrel to be colder than the remainder of the bar and results in a product with varying metallurgical properties. While this latter problem could be overcome by increasing the temperature of the mandrel to the same temperature as that of the transfer bar, this would result in a material decrease in the life of the mandrel and also would result in the phenomenon known as pressure welding. As long as these disadvantages can be tolerated, however, coiler 29 may be of a type employing a mandrel. It has been discovered, however, that a mandrelless coiler can be used for the coiling of a hot transfer bar and avoids the aforementioned disadvantages of a coiler having a mandrel. Mandrelless coilers have been used in the past for coiling cold strip, but their use for coiling a hot transfer bar is believed to be unique. While either a mandrelless upcoiler or a mandrelless downcoiler can be used, the latter is preferred because the former does not lend itself to a subsequent uncoiling operation in a continuous manner without the aid of peelers and pinch rolls. This is an important consideration when one is dealing with a hot transfer bar being processed in a hot strip mill, since subjecting the hot transfer bar to scratches or conditions under which cold spots could occur must be avoided.

Shown in FIG. 6 to 13 inclusive is a mandrelless downcoiler that coils a hot transfer bar into the form of a complete coil and then, in one continuous operation, uncoils the transfer bar in the same direction. The mandrelless downcoiler is designed to avoid scratching of the surface of the hot transfer bar by minimizing the use of mechanical equipment that could result in this undesirable effect. In addition, it is designed to be operated in such a manner as to prevent cold spots from being formed in the hot transfer bar as a result of the hot transfer bar becoming stationary while in contact with a cold metal surface.

Referring to FIGS. 6 and 7, a mandrelless downcoiler 40 includes an entry pinch roll set 41, a set 42 of bending rolls, a set 43 of coil cradle rolls, three drive mechanisms 44, 45 and 46 respectively of any suitable type for the foregoing sets of rolls, an inner wrap retainer 47, a suitable drive mechanism 48 for reciprocating the retainer into and out of position, exit sideguides 49, a standby exit pinch roll 50, a removable cover 51, an emergency peeler 52 and any suitable drive mechanism 53 for peeler 52.

Entry pinch roll set 41 consists of upper and lower driven rolls 54 and 55 respectively mounted with their axes of rotation parallel to each other.

Extending between pinch roll set 41 and bending roll set 42 are deflection plates 56 for guiding the hot transfer bar to the bending roll set. The latter is conventional in nature and consists of one lower and two upper driven rolls 57, 58 and 59 respectively mounted with their axes of rotation parallel to each other and to the axes of rotation of rolls 54 and 55.

Bearing blocks 60 and 61 are provided at each end of rolls 58 and 59 respectively and may be reciprocated up and down along tracks 62 and 63 respectively by means of hydraulically operated pistons (not shown) contained in cylinders 64 and 65 respectively and con-

nected to bearing blocks 60 and 61 via connecting rods 66 and 67 respectively. Cylinders 64 and 65 are mounted on a part 68a of the framework or housing of coiler 40. Of course screw jacks or other devices may be used for moving rolls 58 and 59.

When rolls 57, 58, and 59 are in the position shown in FIG. 6, the hot transfer bar is forced to follow a curved path in passing between the rolls, and the transfer bar receives a permanent bend or curvature. However, rolls 58 and 59 can be retracted when it is desired not to bend the transfer bar.

Cradle roll set 43 consists of three driven cradle rolls 68, 69 and 70 mounted with their axes of rotation parallel to each other and to the axes of rotation of rolls 54, 55, 57, 58 and 59. In a less preferred embodiment cradle roll 70 could be replaced by a skid plate.

Inner wrap retainer 47 normally remains in a retracted position and is not to be confused with a mandrel. A mandrel is a device upon which a material may be coiled. Inner wrap retainer 47, on the other hand, is in its retracted position during the whole of the coiling operation. It is inserted into the hollow core of the coil only towards the end of the uncoiling operation and serves to retain the inner wraps of the coil in position during the last stages of uncoiling.

Exit sideguides 49 assist in the proper formation of the coil and prevent the coil from forming into a telescope configuration.

Peeler 52 normally remains in its retracted position and is not used in the normal operation of coiler 40. However, in emergencies it can be moved into operative position by its drive mechanism 53 and operates to separate the wraps of the coil.

The housing of coiler 40 includes an optional removable cover 51, which has been found not to be required, and other walls 72.

Located ahead of coiler 40 is an entry table 73 including driven table rolls 74 on which the hot transfer bar is transported to coiler 40. An exit table 75 including driven table rolls 76 is located behind the coiler.

Standby exit pinch roll 50 is used only in emergencies and normally is located above the position thereof shown in FIG. 6 and cooperates with one of rolls 76 to form a pinch roll unit.

The location of cradle rolls 68-70 and their speed of rotation relative to the speed of rotation of bending rolls 57-59 is important in ensuring the formation of a proper coil. In this respect, the coil initially is formed on rolls 69 and 70, i.e., during the initial formation of the coil, the curved transfer bar from the set of bending rolls contacts rolls 69 and 70, but not roll 68. After the coil being formed has become quite large, contact is made with rolls 68 and 69, and contact with roll 70 is broken. The location of cradle rolls 68-70 relative to bending rolls 57-59 and the speed of the latter relative to the former must be selected such that the curved transfer bar emerging from the bending roll unit is prevented from following the path that it otherwise would and striking itself somewhere near the entry point to the three roll bending unit and instead is formed into a tight, circular coil. Many different locations and speeds of the cradle rolls are possible, but, in all cases, the cradle rolls should be driven faster than bending rolls 57-59. However, care should be taken not to drive cradle rolls 68-70 so fast as to form so tight a coil as

to cause scratching and galling of the rolls on the transfer bar and of the transfer bar on itself. In general, the cradle rolls should not substantially alter the velocity of the head end of the transfer bar on its first wrap.

The operation of mandrelless downcoiler 40 now will be described with reference to FIGS. 8 to 13 from which it will be noted that suitable hot metal detectors 78 and 79 are disposed over entry and exit tables 73 and 75 respectively.

Prior to initiation of the coiling operation, the components of the coiler are in the positions shown in FIG. 8, i.e., inner wrap retainer 47 retracted and bending rolls 57-59 in operative position. The bending rolls all are being driven at the same speed, as are all of the cradle rolls, this being achieved via drive mechanisms 45 and 46 respectively. The cradle rolls are being driven slightly faster than the bending rolls and the peripheral speed of the latter is the same as that of the transfer bar. Pinch rolls 54 and 55 are driven at the same peripheral speed as that of the bending rolls. Roll 54 is pivotally mounted so that after the transfer bar has reached the bending rolls, it can be raised slightly. It then functions as a guide roll rather than as a part of a pinch roll unit.

Hot metal detector 78 detects the head end of a hot transfer bar. If hot metal detector 79 indicates that coiler 40 is clear, the transfer bar is permitted to enter the coiler. However, if hot metal detector 79 indicates that coiler 40 is not ready to receive the transfer bar (because the previous transfer bar has not yet cleared coiler 40), the drive mechanism (not shown) for table rolls 74 is disconnected therefrom, and the transfer bar is held until the coiler is clear. The aforementioned control operations may be performed electronically using equipment of known type.

The hot transfer bar passes through pinch roll set 41 and is guided by deflection plates 56 into bending roll set 42 where a curvature is imparted thereto. The curved end of the transfer bar heads downwardly toward cradle roll set 43, contacts cradle rolls 69 and 70 and is formed into a tight coil. After the coil has become larger, it falls to the position shown in FIG. 9 where it is supported on cradle rolls 68 and 69.

As shown in FIG. 9, after hot metal detector 78 detects the tail end of the transfer bar, bending rolls 58 and 59 are retracted. This avoids putting a bend or set into the tail end of the transfer bar and facilitates extraction of the tail end prior to uncoiling. Of course, other techniques than using a hot metal detector for sensing the tail end of the transfer bar and retracting bending rolls 58 and 59 may be employed. For example, the quantity of steel passing through the pinch rolls may be measured and the bending rolls retracted shortly before all of the transfer bar passes through the bending roll set.

Turning now to FIG. 10, when the tail end of the transfer bar leaves pinch rolls 54 and 55, a signal is derived and transmitted to drive mechanism 46 by any suitable detection device, and cradle rolls 68-70 are decelerated and brought to rest at the instant that the tail end of the transfer bar leaves bending roll set 42 and passes over the top of the coil. The tail end of the coil then falls freely due to its inertia onto exit table 75, and the direction of rotation of cradle rolls 68-70 automatically is reversed. The transfer bar then is uncoiled being driven tail end first out of coiler 40.

It should be noted that in normal operation the tail end of the transfer bar is not permitted to pass under the coil. However, if a cobble should occur at some point beyond the coiler, cradle rolls 68-70 would be driven to rotate the coil slowly to inhibit the formation of cold spots.

When hot metal detector 79 detects the presence of the hot transfer bar, a signal is produced that is supplied to a control system for the drive mechanism of bending rolls 58 and 59 and these are returned to their operative position as shown in FIG. 11. In addition, this signal may be used to activate the crop shear.

Any suitable device may be employed to determine when the uncoiling operation is near its end and, as shown in FIG. 12, activate inner wrap retainer 47. This retainer is inserted through the hollow core of the coil and serves to retain the last few wraps of the coil during the uncoiling operation.

Referring now to FIG. 13, when hot metal detector 79 ceases to detect hot metal indicating that the transfer bar has cleared the coiler, a signal is derived and used to reset the coiler (inner wrap retainer 47 returned to its retracted position), release an interlock on hot metal detector 78 to permit the next transfer bar to enter coiler 40 and activate crop shear for a tail end (previously the head end of the transfer bar) cut.

As aforementioned, a mandrelless upcoiler, although less preferred than a mandrelless downcoiler, could be used in place thereof. It will be understood that whereas in a mandrelless downcoiler the end of the transfer bar that first enters the downcoiler bends downwardly to form a coil, in a mandrelless upcoiler this end bends upwardly to form a coil.

While various embodiments of the different aspects of this invention have been disclosed in detail herein, those skilled in the art will appreciate that changes and modifications may be made therein without departing from the spirit and scope of this invention as defined in the appended claims.

What I claim as my invention:

1. A method for processing hot metal workpieces in a rolling mill of the type that includes a first mill comprising a reversing mill stand, a second mill comprising at least one mill stand and coiler means located between said first and second mills for coiling a hot metal workpiece delivered thereto from said first mill before said hot metal workpiece is rolled in said second mill, said method comprising the following steps:

a. delivering a hot metal workpiece to said first mill;

b. rolling said hot metal workpiece in said first mill by passing said hot metal workpiece back and forth through said reversing mill stand in a series of passes from one side thereof to the other side thereof and vice-versa, on the third last pass of said hot metal workpiece through said reversing mill stand passing said hot metal workpiece from the side of said reversing mill stand further from said coiler means to the side thereof closer to said coiler means and rolling said hot metal workpiece to a length less than the spacing between said reversing mill stand and said coiler means without coiling said hot metal workpiece in said coiler means, on the last pass of said hot metal workpiece through said reversing mill stand again passing said hot metal workpiece from the side of said reversing mill stand further from said coiler means to the side

thereof closer to said coiler means and rolling said hot metal workpiece to a length greater than the spacing between said reversing mill stand and said coiler means;

- c. coiling said hot metal workpiece from said first mill in said coiler means after said last pass;
 - d. thereafter uncoiling said hot metal workpiece from said coiler means;
 - e. subsequently delivering the said hot metal workpiece to said second mill; and
 - f. rolling said hot metal workpiece in said second mill.
2. A method according to claim 1 wherein said rolling mill includes a crop shear located between said coiler means and said second mill and wherein on said last pass through said reversing mill stand said hot metal workpiece is rolled to a length greater than the spacing between said reversing mill stand and said crop shear.
 3. A method according to claim 1 wherein on said last pass through said reversing mill stand said hot metal workpiece is rolled to a length greater than the spacing between said reversing mill stand and the first mill stand of said second mill.
 4. A method according to claim 1 wherein said hot metal workpiece has a head end and a tail end, said hot metal workpiece being delivered to and coiled in said coiler means head end first but being delivered from said coiler means tail end first.
 5. A method according to claim 1 wherein said first mill is a roughing mill and said second mill is a finishing mill.

6. A method according to claim 1 wherein said rolling mill is a hot strip mill and said hot metal workpiece delivered to said second mill is a hot metal strip.

7. A method according to claim 1 wherein said hot metal workpiece has a head end and a tail end, said hot metal workpiece being delivered to and coiled in said coiler means head end first but being delivered from said coiler means tail end first, wherein said first mill is a roughing mill and said second mill is a finishing mill and wherein said rolling mill is a hot strip mill and said hot metal workpiece delivered to said second mill is a hot metal strip.

8. A method according to claim 1 wherein said coiler is a mandrelless coiler.

9. A method according to claim 8 wherein said mandrelless coiler is a mandrelless downcoiler.

10. A method according to claim 9 wherein said hot metal workpiece has a head end and a tail end, said hot metal workpiece being delivered to and coiled in said coiler means head end first but being delivered from said coiler means tail end first, wherein said first mill is a roughing mill and said second mill is a finishing mill and wherein said rolling mill is a hot strip mill and said hot metal workpiece delivered to said second mill is a hot metal strip.

11. A method according to claim 1 wherein said hot metal workpiece is uncoiled substantially immediately after coiling, whereby said hot metal workpiece is substantially continuously in motion from the commencement of coiling thereof to the termination of uncoiling thereof.

* * * * *

35

40

45

50

55

60

65