



(22) Date de dépôt/Filing Date: 2004/01/30
 (41) Mise à la disp. pub./Open to Public Insp.: 2004/07/30
 (45) Date de délivrance/Issue Date: 2008/07/15
 (30) Priorité/Priority: 2003/01/30 (US60/443,768)

(51) Cl.Int./Int.Cl. *E21B 33/16* (2006.01),
E21B 33/134 (2006.01)

(72) Inventeurs/Inventors:
 GIROUX, RICHARD L., US;
 BRUNNERT, DAVID J., US;
 GALLOWAY, GREGORY GUY, US;
 JORDAN, CHRIS, US

(73) Propriétaire/Owner:
 WEATHERFORD/LAMB, INC., US

(74) Agent: DEETH WILLIAMS WALL LLP

(54) Titre : BOUCHON DE CIMENTATION UNIDIRECTIONNEL
 (54) Title: SINGLE-DIRECTION CEMENTING PLUG

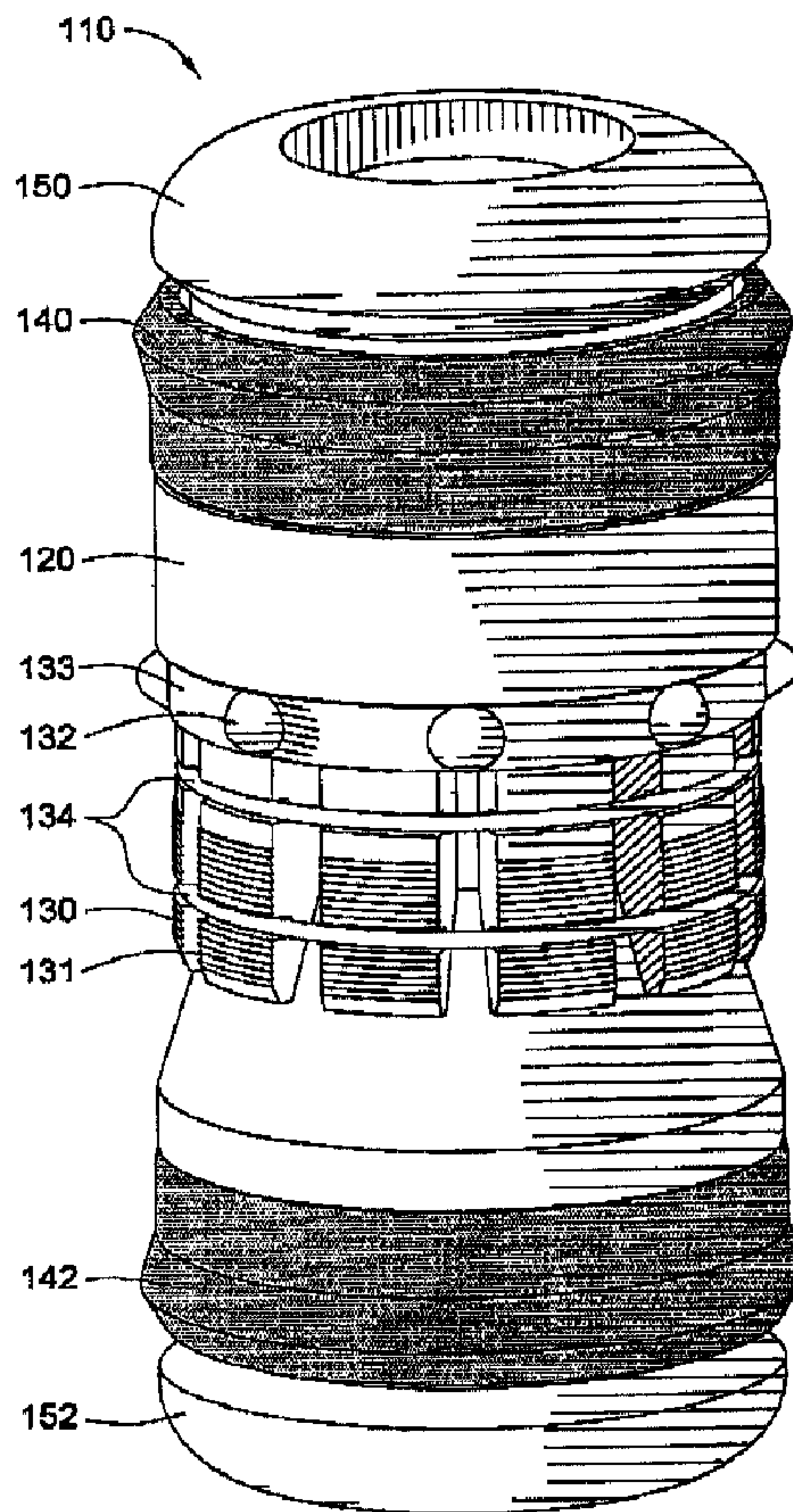

(57) Abrégé/Abstract:

The present invention generally relates to apparatus and methods for completing a well. Particularly, the present invention relates to a single-direction plug for use with cementing applications and with drilling with casing applications. One embodiment comprises a

(57) **Abrégé(suite)/Abstract(continued):**

cement plug for installation in a wellbore casing. The plug includes a body and gripping members for preventing movement of the body in a first axial direction relative to the casing. The plug further comprises a sealing member for sealing a fluid path between the body and the casing. The plug is movable in a second axial direction with fluid pressure but is not movable in the first direction due to fluid pressure.

ABSTRACT OF THE DISCLOSURE

The present invention generally relates to apparatus and methods for completing a well. Particularly, the present invention relates to a single-direction plug for use with cementing applications and with drilling with casing applications.

5 One embodiment comprises a cement plug for installation in a wellbore casing. The plug includes a body and gripping members for preventing movement of the body in a first axial direction relative to the casing. The plug further comprises a sealing member for sealing a fluid path between the body and the casing. The plug is movable in a second axial direction with fluid pressure but is not movable in the first
10 direction due to fluid pressure.

SINGLE-DIRECTION CEMENTING PLUG

BACKGROUND OF THE INVENTION

Field of the Invention

The present invention generally relates to apparatus and methods for completing a well. Particularly, the present invention relates to positioning a plug in a wellbore. More particularly, the present invention relates to a single-direction plug for use in well completions and drilling with casing applications.

Description of the Related Art

In the oil and gas producing industry, the process of cementing casing into the wellbore of an oil or gas well generally comprises several steps. For example, a string of casing is run in a wellbore to the required depth. Then, cement slurry is pumped into the casing to fill an annulus between the casing and the wellbore wall to a desired height. A displacement medium, such as a drilling or circulation fluid, is pumped behind the cement in order to urge the cement to exit the inside of the casing and enter the annulus. The cement slurry is typically separated from the circulation fluid by at least one cementing plug. Due to the difference in specific gravity between the circulating fluid and the cement slurry, the heavier cement slurry initially drops inside the casing without being pumped by hydrostatic pressure. After the height of cement slurry column outside the casing equals the height of the cement slurry column inside the casing, hydrostatic pressure must be exerted on the displacement fluid to force the rest of cement slurry out of the casing and into the annulus.

After the desired amount of cement slurry has been pumped into the annulus, it is desirable to prevent the backflow of cement slurry into the casing until the cement slurry sets and hardens. This backflow is created by the difference in specific gravity of the heavier cement and the generally lighter displacement fluid. One method for preventing the backflow of cement slurry into the casing involves holding constant the hydrostatic pressure on the displacement fluid in the casing until

the cement slurry sets and hardens. This method, however, expands the casing and creates non-adherence of the casing to the hardened cement after the hydrostatic pressure in the casing is released and the casing string contracts. Another method of preventing the backflow of cement slurry involves placing a check valve in the lower end of the casing string to prevent the backflow of the cement slurry into the casing. The check valve may be run on a conventional casing string or pumped down the casing and latched into a float collar with a recess near the bottom of the casing string. Then, the cement slurry is pumped through the check valve. One problem with the use of a check valve in preventing the backflow of cement slurry is that flowing a cement slurry or other fluid through the check valve may damage the check valve and may prevent the check valve from functioning properly. In addition, installing a check valve, even in the open position, on a lower portion of a casing string can cause a pressure surge within the wellbore, thereby damaging surrounding hydrocarbon-bearing formations.

Recently, drilling with casing has become popular as a time saving way to complete a well. Drilling with casing involves using a casing string as a drill string to form a borehole and then using the same string to line the wellbore. Typically, a cutting member is placed at the lower end of the string and is later either retrieved or destroyed by subsequent drilling of another section of wellbore. One challenge of drilling with casing is providing a cementing apparatus in the string to facilitate the circulation of cement after the wellbore is formed. As described above, some type of one-way valve is typically used. However, because drilling fluid must be circulated through the string as the wellbore is formed, any valve in the string can hamper the circulation of fluid that is necessary for drilling

Therefore, a need exists for an improved cementing apparatus for use in completing wells. There is a further need for an improved method of positioning a plug in a wellbore. There is also a need for a downhole tool capable of positioning at a desired depth in the wellbore.

SUMMARY OF THE INVENTION

The present invention generally relates to apparatus and methods for completing a well. Particularly, the present invention relates to a single-direction cementing plug for use with conventional well completions and with drilling with casing applications. One embodiment comprises a cement plug for installation in wellbore casing. The plug includes a body and gripping members for preventing movement of the body in a first axial direction relative to the casing. The plug further comprises a sealing member for sealing a fluid path between the body and the casing. The plug is movable in a second axial direction with fluid pressure but is not movable in the first direction due to fluid pressure.

In another aspect, the present invention provides a method of completing a wellbore. The method includes positioning a tubular in the wellbore and disposing a one-way traveling plug in the tubular. Thereafter, the one-way traveling plug may engage the tubular using a gripping member. The method also includes locating cement in an annular area between the tubular and the wellbore. In one embodiment, the tubular comprises a casing.

In another aspect, the present invention provides a cementing plug for cementing a tubular in a wellbore. The plug includes a body and one or more gripping members, wherein the gripping members, when actuated, prevent movement of the body in a first axial direction relative to the tubular, and, when not actuated, allow movement of the body in a second axial direction relative to the tubular.

In another aspect still, the present invention provides a plug for installation in a casing. The plug includes a body and one or more selectively actuatable gripping members for positioning the plug in the wellbore, wherein the one or more gripping members grip the casing to prevent movement of the plug in a first axial direction relative to the casing but allow movement of the plug in a second axial direction relative to the casing.

In another aspect still, the present invention provides a method of installing a

cement plug in a casing to cement the casing in a wellbore. The method includes running the casing into the wellbore. Thereafter, a cement plug having a body and a gripping member for preventing axial movement of the body is disposed in the casing. At the desired location, the gripping members are activated to prevent the
5 plug from moving axially.

In another aspect still, the present invention provides a method of positioning a tool in a fluid conduit. The method includes disposing the tool in the fluid conduit and urging the tool, having one or more gripping members, in a first direction in the fluid conduit. Thereafter, the tool is caused to engage a wall of the fluid conduit at a
10 desired location using the one or more gripping members of the tool, thereby preventing movement of the tool in a second direction within the fluid conduit. Preferably, the fluid conduit comprises a hydrocarbon conduit such as a wellbore or a pipeline. In one embodiment, the tool comprises a downhole tool. In another aspect, the tool may be used to separate two fluid bodies in the fluid conduit.
15 Exemplary fluid bodies include cement, drilling fluid, or hydrocarbon.

Another embodiment comprises a method of installing a cement plug in a well. The method includes running a string of wellbore casing into a wellbore. Then, a quantity of cement is injected into the casing in an amount adequate to fill a predetermined annular volume between the casing and the wellbore therearound.
20 Then, the cement plug is installed at an upper end of the casing. The cement plug includes a body and gripping members for preventing movement of the body towards a surface of the well. The cement plug further includes a sealing member for sealing a fluid path between the body and the casing. Then, the plug is urged downwards to a desired depth in the wellbore with a second fluid. The plug separates the cement
25 therebelow from the second fluid injected above the plug. Then, the gripping members are caused to set, thereby preventing the movement of the plug towards the surface of the well.

Yet another embodiment comprises a method of installing a cement plug in a well. The method includes drilling a wellbore with a string of casing having a cutting
30 member disposed on a lower portion of the string. Then, a quantity of cement is

injected into the casing in an amount adequate to fill a predetermined annular volume between the casing and the wellbore therearound. Then, the cement plug is installed at an upper end of the casing. The cement plug includes a body and gripping members for preventing movement of the body towards a surface of the well. The cement plug further includes a sealing member for sealing a fluid path between the body and the casing. Thereafter, the plug is urged downwards to a desired depth in the wellbore with a second fluid. The plug separates the cement therebelow from the second fluid injected above the plug. Then, the gripping members are caused to set, thereby preventing the movement of the plug towards the surface of the well.

BRIEF DESCRIPTION OF THE DRAWINGS

So that the manner in which the above recited features of the present invention, as well as other features set forth herein, are attained and can be understood in detail, a more particular description of the invention, briefly summarized above, may be had by reference to the embodiments thereof which are illustrated in the appended drawings. It is to be noted, however, that the appended drawings illustrate only typical embodiments of this invention and are therefore not to be considered limiting of its scope, for the invention may admit to other equally effective embodiments.

Figure 1 is a schematic perspective view of one embodiment of a single-direction plug.

Figure 2 is a schematic cross-sectional view of the single-direction plug of Figure 1 in an unactuated position.

Figure 3 is a schematic cross-sectional view of the single-direction plug of Figure 1 in an actuated position.

Figure 4 is a schematic perspective view of another embodiment of a single-direction plug.

Figure 5 is a schematic cross-sectional view of the single-direction plug of Figure 4 in an unactuated position.

Figure 6 is a schematic cross-sectional view of the single-direction plug of Figure 4 in an actuated position.

5 Figure 7 is a schematic cross-sectional view of another embodiment of a single direction plug according to aspects of the present invention in an unactuated position.

Figure 8 is a schematic cross-sectional view of the single direction plug of Figure 7 in an actuated position.

10 Figure 9 is a schematic cross-sectional view of another embodiment of a single direction plug according to aspects of the present invention in an unactuated position.

Figure 10 is a schematic cross-sectional view of the single direction plug of Figure 9 in an actuated position.

15 Figure 11 is a partial schematic cross-sectional view of another embodiment of a single-direction plug according to aspects of the present invention.

Figure 12 is a partial schematic cross-sectional view of another embodiment of a single-direction plug according to aspects of the present invention.

20 Figure 13 is a partial schematic cross-sectional view of another embodiment of a single-direction plug according to aspects of the present invention.

Figure 14 is a schematic cross-sectional view of another embodiment of a single-direction plug according to aspects of the present invention.

Figure 15 is a schematic view of single-directions plugs used in a drilling with casing application.

DETAILED DESCRIPTION OF THE PREFERRED EMBODIMENT

The present invention generally relates to apparatus and methods for completing a well. Particularly, the present invention relates to a single-direction cementing plug.

5 Figure 1 is a schematic perspective view of one embodiment of a single-direction plug 110. The single-direction plug 110 may include a cylindrical body 120, one or more gripping members 130, a garter spring 134, a drag element 132, sealing members 140, 142, and end caps 150, 152. Figure 2 is a schematic cross-sectional view of the single-direction plug 110 of Figure 1 in an unactuated position disposed
10 within a casing 104 lining a portion of a vertical wellbore 102. The annulus 106 between the casing 104 and the wellbore 102 is typically filled with a fluid, such as a cement slurry, to strengthen the walls of the wellbore and facilitate isolation of certain areas of the wellbore. The plug 110 may separate a first fluid 109, such as a cement slurry, from a second fluid 108, such as a displacement fluid, within the casing 104.
15 The plug 110 is described in greater detail below using terms designating orientation. These terms designating orientation are only used for clarity reasons in reference to the vertical wellbore 102 and should not be deemed to limit the scope of the present invention. In other embodiments, the plug 110 may be disposed in a non-vertical wellbore, such as a horizontal wellbore.

20 The cylindrical body 120 of the plug 110 includes a bore 127 therethrough and a seal 128 to prevent the flow of fluid through the bore 127 and the body 120. A top end cap 150 may be coupled to the top end of the body 120 and a bottom end cap 152 may be coupled to the bottom end of the body 120. The end caps 150, 152 may comprise a rounded surface to help direct the plug 110 through the casing 104.

25 A top sealing member 140 may be coupled to the top end of the body 120, and a bottom sealing member 142 may be coupled to the bottom end of the body 120. The sealing members 140, 142 comprise lips 141, 143 which make movable contact with the inner walls of the casing 104. The lip 141 of the top sealing member 140 is directed upward to help isolate the second fluid 108 above the plug 110 while
30 the lip 143 of the bottom sealing member 142 is directed downward to help isolate

the first fluid 109 below the plug 110. The lips 141, 143 of the sealing members 140, 142 preferably comprise an elastic material. As shown in the figure, the body 120 comprises two pieces. In other embodiments, the body 120 may comprise one integral piece or three or more separate pieces.

5 The body 120 of the plug 110 further comprises a sloped portion 122 having a narrow region 124 above a wide region 126. The gripping members 130 are at least partially disposed around the sloped portion 122 of the body 120 and are moveable axially between the narrow region 124 and the wide region 126 of the sloped portion 122 of the body 120. The gripping members 130 may comprise
10 multiple components as shown in Figure 1. Referring again to Figure 2, one or more garter springs 134 are disposed around the gripping members 130 to bias the gripping members 130 against the body 120.

 The gripping members 130 are disposed proximate to the drag element 132. In the figure, the drag element 132 comprises drag buttons disposed on a
15 slideable ring 133. Other types of drag elements 132 may also be used. As shown, the gripping members 130 are not attached to the drag element 132. In other embodiments, the gripping members 130 may be attached to the drag element 132. As the plug 110 is directed down the wellbore 102, the drag element 132 drags against the inner walls of the casing 104 and urges the slideable ring 133 upward
20 relative to the body 120. The garter spring 134 biases the gripping members 130 against the body 120, and biases the gripping members 130 upward relative to the body 120 toward the slideable ring 133. Since the slideable ring 133 and the gripping members 130 are urged upward, the gripping members 130 are at the narrow region 124 of the sloped portion 122 of the body 120 and are prevented from
25 making contact with the inner walls of the casing 104. In other words, the gripping members 130 are in a retracted position, and, thus, do not hinder downward movement of the plug 110 through the casing 104.

 Figure 3 is a schematic cross-sectional view of the single-direction plug 110 of Figure 2 in an actuated position. In one aspect, the plug 110 is actuated by
30 causing the pressure below the plug 110 to be greater than the pressure above the

plug 110, thereby forcing the plug 110 to move up the casing 104. As the plug 110 is directed up the casing 104, the drag element 132 drags against the inner walls of the casing 104 and urges the slideable ring 133 downward relative to the body 120. The slideable ring 133 contacts the gripping members 130 and moves the gripping members 130 downward relative to the body 120 against the bias of the garter spring 134. As a consequence, the gripping members 130 are urged to the wide region 126 of the sloped portion 122 of the body 120. Due to the larger outer diameter of the wide region 126, the gripping members 130 are forced outward against the bias of the garter springs 134, thereby contacting the inner walls of the casing 104. In this respect, the gripping members 130 may become wedged between the inner wall of the casing 104 and the body 120, thereby preventing upward movement of the plug 110. In another aspect, the gripping members 130 may further comprise gripping elements 131, such as teeth, bumps, or other irregular, non-smooth, or jagged surfaces, to facilitate engagement of the gripping members 130 with the casing 104, and to help prevent movement of the plug 110. In another embodiment, the gripping members may comprise a spring-loaded hydraulic anchor, as disclosed in U.S. Patent Number 3,131,769, to *de Rochemont*.

Figure 4 is a schematic perspective view of another embodiment of a single-direction plug 210. The single-direction plug 210 may include a cylindrical body 220 (Figure 5), gripping members 230, a drag element 232, a sealing member 242, and an end cap 252. Figure 5 is a schematic cross-sectional view of the single-direction plug 210 of Figure 4 in an unactuated position disposed within a casing 204 lining a portion of the wellbore 202. The annulus 206 between the casing 204 and the wellbore 202 may be filled with a fluid, such as a cement slurry, or may be unfilled. The plug 210 may separate a first fluid 209, such as a cement slurry, from a second fluid 208, such as a displacement fluid, within the casing 204. The plug 210 is described in greater detail below using terms designating orientation. These terms designating orientation are only used for clarity reasons in reference to the vertical wellbore 202 and should not be deemed to limit the scope of the present invention. In other embodiments, the plug 210 may be disposed in a non-vertical wellbore, such

as a horizontal wellbore.

The cylindrical body 220 includes a bore seal 228 to prevent the flow of fluid through the body 220. A bottom end cap 252 may be coupled to the bottom end of the body 220. The end cap 252 may comprise a rounded surface to help direct the plug through the casing 204. A bottom sealing member 242 may be coupled to the bottom end of the body 220. The sealing member 242 comprises a lip 243 which makes slideable contact with the inner walls of the casing 204. The lip 243 of the bottom sealing member 242 is directed downward to help isolate the first fluid 209 below the plug 210. The lip 243 preferably comprises an elastic material. The body 220 may comprise an integral piece or multiple pieces.

The body 220 of the plug 210 further comprises a sloped portion 222 having a narrow region 224 above a wide region 226. The gripping members 230 are disposed around the sloped portion 222 of the body 220 and are moveable axially between the narrow region 224 and the wide region 226 of the sloped portion 222 of the body 220. The gripping members 230 may comprise multiple components as shown in Figure 4. Referring again to Figure 5, the gripping members 230 are disposed in a first set of t-shaped dovetail grooves in the slideable sleeve 236 and are disposed in a second set of t-shaped dovetail grooves in the body 220.

In the figure, the drag element 232 comprises fins 233 and lip 234 coupled to the slideable sleeve 236. The lip 234 of drag element 232 acts as a sealing device and helps to isolate the second fluid 208 above the plug 210. Other drag elements 232 may also be used. As the plug 210 is directed down the wellbore 202, the drag element 232 drags against the inner walls of the casing 204 and urges the slideable sleeve 236 upward relative to the body 220. Since the gripping members 230 are disposed in the grooves of the slideable sleeve 236, the gripping members 230 are also urged upward relative to the body 220 to the narrow region 224 of the sloped portion 222 of the body 220. Since the gripping members 230 are at the narrow region 224 of the sloped portion 222 of the body 220, the gripping members 230 are prevented from making contact with the inner walls of the casing 204. In other words, the gripping members 230 are in a retracted position, and, thus, do not

hinder downward movement of the plug 210 through the casing 204.

Figure 6 is a schematic cross-sectional view of the single-direction plug 210 of Figure 4 in an actuated position. As the plug 210 is directed up the casing 204, the drag element 232 drags against the inner walls of the casing 204 and urges the slideable sleeve 236 downward. Since the gripping members 230 are disposed in the grooves of the slideable sleeve 236, the gripping members 230 are also urged downward relative to the body 220. As a consequence, the gripping members 230 are urged to the wide region 226 of the sloped portion 222 of the body 220. Due to the larger outer diameter of the wide region 226 of the sloped portion 222 of the body 220, the gripping members 230 are also urged outward from the grooves of the slideable sleeve 236 and the body 220 to make contact with the inner walls of the casing 204, and may become wedged thereagainst. In other words, the gripping members 230 are in an expanded position, and thus, help prevent upward movement of the plug 210 through the casing 204. The gripping members 230 may further comprise gripping elements 231, such as teeth, bumps, or other non-smooth surfaces, to help prevent movement of the plug 210.

Tension pins 260 preventing movement of the slideable sleeve 236 relative to the body 220 may be used to prevent movement of the gripping members 230 during handling at the well surface or may prevent premature setting of the gripping members 230 during run in. For example, a tension pin 260 may be disposed in the top of the body 220 and in the slideable sleeve 236 as shown in Figure 5. The tension pins 260 can be broken by exposing the plug 210 to a sufficient upward force against the body 220.

In another aspect, the single-direction plug may be launched from a conventional plug container or as a sub-surface release type plug. Examples of sub-surface release type plugs are disclosed in U.S. Patent No. 5,843,157. In one aspect, less time is employed in using a single-direction plug in comparison to a latch-in check valve which is typically pumped down the casing prior to use, such as prior to beginning a cementing process.

Single-direction plugs according to aspects of the present invention may be made of any suitable material, such as polymers, composites, elastomers, plastomers, fiber reinforced materials, metals, alloys, or combinations thereof. The plugs or portions thereof may also be made of wood or wood product such as plywood, or plastics such as thermo set or compression set. Preferably, the plugs are made of a drillable or millable material, comprising a single substance or a composite material, which may be drilled by any industry known drill bit so that the plug may be drilled out and further operations be performed down the wellbore. Additionally, the gripping members 130 and the gripping elements 131 may comprise a single material, such as, but not limited to, cast iron, aluminum, or a ceramic material, or they may comprise a composite material, such as, but not limited to, an engineering grade plastic. Additionally, the embodiment wherein gripping members 130 and/or the gripping elements 131 comprise aluminum may further comprise aluminum with a hard, anodized or other surface coating.

A single-direction plug according to aspects of the present invention may be used in a variety of applications. In one embodiment, a single-direction plug may be used to separate cement slurry and displacement fluid used to pump the cement slurry down a casing and up the annulus. If the plug is exposed to a greater pressure below the plug (*i.e.* the pressure of the cement slurry below the plug is greater than the pressure of the displacement fluid above the plug), the gripping members 130 or 230 of the plugs 110 or 210, respectively, will be actuated to prevent movement of the plug up the casing. In this respect, the plugs are also known as one-way traveling plugs or unidirectional plugs. The gripping members 130 or 230 of the plugs 110 or 210, respectively, may be actuated at any desired location in the casing by exposing the plug to a greater pressure below the plug. Further, the plug may be actuated and de-actuated multiple times within the wellbore by controlling the pressure of the displacement fluid above the plug. Additionally, the location of the plug in the casing may be ascertained and controlled by means well known within the relevant art, such as the use of a radio frequency identification

device (RFID), as generally described in U.S. patent 3,054,100.

Figure 7 is a schematic cross-sectional view of another embodiment of a single direction plug in an unactuated position according to aspects of the present invention. The plug is provided with a seal 128 comprising a shearable member 728, such as a rupture disc or shearable membrane. As shown, the shearable member 728 is disposed at the top portion of the plug, however, such positioning is not a limitation of the invention and the shearable member 728 may be disposed at any location along the length of bore 127. The shearable member 728 may be constructed to selectively allow the fluid to pass through the body 120. Preferably, the shearable member 728 is constructed to shear or break at a predetermined pressure. Additionally, the single-direction plug 110 may include a valve 700 to control fluid flow through the bore 127 of the body 120.

Figure 8 is a schematic cross-sectional view of the single direction plug of Figure 7 in an actuated position. As illustrated therein, once the plug 110 has reached a desired location and the plug is set, fluid pressure from above may be applied to rupture the shearable member 728, thereby allowing fluid to pass through the plug 110. In another embodiment, the plug 110 may include bi-directional gripping members such as those shown in Fig. 14. In this manner, the plug 110 may be set in the casing such that it will not move in either direction.

In another aspect, when the plug 110 remains in one location, opening the valve 700 allows the fluid to pass through the plug 110. The valve 700 may be a single direction valve such as a flapper valve. In this respect, the flapper valve may act as a check valve and keep the fluid pumped through the plug from flowing back through the plug. Furthermore, the flapper valve 700 may be adapted to allow movement of the plug 700 once the flapper valve 700 is closed. In this respect, the flapper valve 700 may function as the seal 128, or the shearable member 728, thereby allowing the plug 110 to once again move in a single direction as dictated by the fluid pressure in the casing 104. The plug 110 may continue to travel in one direction until a desired depth is reached and the gripping members are set to prevent axial movement of the plug.

The single-direction plug may also be used in other applications besides cementing operations. Additionally, it can be actuated by means other than those previously described. For example, using a combination of a timer and a gauge to measure hydrostatic head, the device can be made to actuate at a specific depth in the wellbore. By requiring that time and pressure conditions be met, chances of the device prematurely activating are reduced. Preferably, when the time and pressure conditions are met, a pressure chamber within the device can provide force to mechanically set the slips and lock the device axially in the wellbore. In another alternative, a frangible member, like a rupture disk can be utilized. The rupture disk, designed to rupture at a particular depth, could permit pressurized fluid pressurized by hydrostatic head to enter an air or vacuum chamber and provide setting force for the slips. Finally, the device can be made whereby the gripping members are bi-directional slips that prevent movement in either axial direction. In this embodiment, the device could be used as a bridge plug in a plug and abandon operation where cement is permanently left in the interior of a wellbore to prevent migration of fluids towards the surface of an abandoned well. The device may also be used as a pump down cement retainer, float valve, or other suitable downhole apparatus as is known to a person of ordinary skill in the art.

Figure 9 is a schematic cross-sectional view of another embodiment of a single-direction plug 910 in an unactuated position. As shown, a flow device 937 is disposed below the drag element 932. The flow device 937 includes an opening 935 whereby compressed fluid contained within the area 909 between the cylindrical body 920 and the casing 904 may be selectively released into the casing 904 above the plug 910. Preferably, the flow device 937 only allows unidirectional flow to prevent undesired flow in the reverse direction; that is, flowing back into the area 909 between the cylindrical body 920 and the casing 904. This flow device 937 may comprise a check valve, a displaceable o-ring seal, or any other suitable unidirectional flow device. Preferably, the flow device 937 is actuated by pressure and opens when the pressure in the area 909 between the cylindrical body 920 and the casing 904 exceeds the pressure above the plug 910. In one embodiment, the flow device 937 comprises an o-ring as illustrated in Figures 9 and 10. In the

unactuated position, the pressure above the plug 910 forces the o-ring 938 into the o-ring seat 939, thereby closing off the flow device 937.

Figure 10 is a schematic cross-sectional view of the single-direction plug 910 of Figure 9 in an actuated position. As the plug 910 is directed up the casing 904, the gripping members 930 are urged outward into engagement with the casing 904. Additionally, the area 909 between the cylindrical body 920 and the casing 904 decreases in size, thereby increasing the pressure in the area 909. The increase in pressure causes the flow device 937 to actuate, specifically, the pressure forces the o-ring 938 to be displaced from the o-ring seat 939. In turn, the flow device 937 is opened to allow fluid in the area 909 to release into the casing 904 above the plug 910.

In another embodiment, a sealing element 944 may be disposed at the upper end of sealing member 942, abutting a notched section of wide region 926 of body 920, as illustrated in Figure 9. The sealing element 944 preferably comprises a flexible material, such as an elastic material. When the pressure of the fluid below the plug 910 increases, the sealing member 942 is caused to move upward. In turn, sealing element 944 is compressed between the sealing member 942 and the abutment, thereby forcing the sealing element 944 to bend outward into contact with the casing 904, as shown in Figure 10.

In another aspect, the shearable member 928 may be adapted to shear or break at two different pressures. For example, shearable member 928, may comprise a top surface 929, having a surface area A_t , which is in contact with the fluid above the plug 910, and a bottom surface 931, having a surface area A_b , which is in contact with the fluid below the plug 910. As shown, the surface area A_t of the top surface 929 is smaller than the surface area A_b of the bottom surface 931, as illustrated in Figures 9 and 10. Due to the difference in size between A_t and A_b , shearable member 928 is shearable by two different pressures. Specifically, the shearable member 928 is adapted to shear or break at a lower pressure exerted against top surface 929, while a greater pressure exerted against the bottom surface 931 is required to shear the shearable member 928 from below the plug 910.

In another embodiment, the end caps 952 may further comprise castellations 953 disposed in various sections of the end cap surface, as illustrated in Figure 11. The castellations 953 serve to improve contact with the bottom of the wellbore and/or cement set below the plug 910 and prevent rotation of the plug 910 which might be caused, for example, by contact with the drill bit when the plug 910 is being drilled out. In a further embodiment, the castellations 954 are disposed at an angle not parallel to the long axis of the plug 910, as illustrated in Figure 12. It is contemplated that the castellations may be any suitable shape as is known to a person of ordinary skill in the art.

Figure 13 is a schematic cross-sectional view of another embodiment of a single-direction plug 910. In this embodiment, gripping members 930 may comprise a hollowed-out section 938 disposed in a non-loading portion of the gripping members 930. In this respect, a smaller amount of material is required to be drilled out and removed to facilitate the drilling out of the plug 910.

Figure 14 is a schematic cross-sectional view of another embodiment of a single-direction plug. In this embodiment, a ratchet mechanism 960 is employed wherein snap ring 963 disposed on the narrow region 924 of the body 920 is situated to engage notches 965 disposed on the inner surface of the slideable sleeve 936 when the plug 910 is in an actuated position. In this embodiment, the ratchet mechanism 960 prevents the gripping members 930 from retracting after engaging the casing. Once the ratchet mechanism 960 is set, the plug 910 may be employed as a bridge plug, landing surface for plugs, regular float valve, or any other suitable application known to a person of ordinary skill in the art.

In another aspect, the single-direction plug may be inserted into the casing after the casing has been run in the wellbore. In this respect, the inner bore of the casing is not obstructed, and therefore, pressure surge problems are avoided. Furthermore, as the plug may be positioned at any location in the casing, a float collar or shoe, as was heretofore necessary using existing technology to secure the plug in a desired position, is not required. Once a casing is properly positioned and ready for cementing, a plug 110 or 210 may be released into the wellbore. The plug

110 or 210 may be caused to stop at any desired location therein to regulate the flow of cement.

In another embodiment, the single-direction plug may be used to facilitate cementing in drilling with casing applications. For example, referring to Figure 15, the casing string 804, with a drill bit 806 attached at one end, may be used to drill a wellbore 802 by pumping drilling fluid therethrough. After the hole has been drilled to a desired depth, the casing string 804 remains in the wellbore 802 and is cemented in the wellbore 802. During the cementing operation, a first plug 811 may be used to separate the drilling fluid and the cement 809 as the cement 809 is pumped into the casing 804. At the desired depth, the first plug 811 may be actuated to position itself in the wellbore 802. Thereafter, pressure above the first plug 811 may be increased to break the shearable membrane in the first plug 811 to allow cement 809 to pass through.

Additionally, a second plug 812 may be disposed in the casing 804 to separate the cement 809 and the fluid for urging the cement 809 downward. As shown, the shearable member of the second plug 812 remains in tact to separate the fluids. It can also be seen that some of the cement 809 has been displaced into the annular area 819 between the wellbore 802 and the casing 804. In addition to separating the fluids, the second plug 812 prevents the cement 809 in the annular area 819 from returning into the casing 804. After a sufficient amount of cement has been displaced into the annular area 819, the second plug 812 may be actuated to position itself in the wellbore 802. Specifically, a pressure differential is created such that the pressure above the second plug 812 is less than the pressure below the second plug 812. In turn, the gripping members of the second plug 812 are actuated to engage the casing 804, thereby maintaining its position in the wellbore 802 and preventing cement 809 from flowing back into the casing 804. It must be noted, either one or both of the plugs 811, 812 may be a single directional plug. The use of single direction plugs advantageously allows drilling with casing to be performed without the need of float equipment. Additionally, because such a single direction plug is disposed in the casing after the drilling operation, the plug is not exposed to

the drilling fluid, and thus, is not degraded or damaged by drilling fluid.

In still another embodiment, a single-direction plug may be used to advantage with other plugs. For example, a cement slurry may be pumped down the casing with a latch-in bottom plug inserted into the casing prior to the cement slurry and with a single-direction top plug inserted after the cement slurry. The latch-in bottom plug may latch into a collar positioned near the bottom of the casing string. The bottom plug may include a fractable member to allow the cement slurry to pass therethrough. When the single-direction top plug is pumped down to the bottom plug, the bottom plug acts as a stop which prevents further downward movement of the single-direction top plug. It must be noted that the single-direction plug may also be employed as the top plug, bottom plug, or both.

Aspects of the present invention may also be applied to a tool traveling in a fluid conduit. In one embodiment, the tool may be equipped with a gripping member. The tool is disposed in the fluid conduit and caused to travel in a first direction. Thereafter, the gripping members may be actuated to engage a wall of the fluid conduit at a desired location, thereby preventing movement of the tool in a second direction within the fluid conduit. Preferably, the fluid conduit comprises a hydrocarbon conduit such as a wellbore, a pipeline, or a casing. In one embodiment, the tool comprises a downhole tool, which may be released to travel in a first axial direction in the casing. Thereafter, the downhole tool may be caused to grip the casing, thereby preventing the downhole tool to travel in a second axial direction. In another aspect, the tool may be used to separate two fluid bodies in the fluid conduit. Exemplary fluid bodies include cement, drilling fluid, hydrocarbon, and combinations thereof.

While the foregoing is directed to embodiments of the present invention, other and further embodiments of the invention may be devised without departing from the basic scope thereof, and the scope thereof is determined by the claims that follow.

We claim:

1. A method of completing a wellbore, comprising:
positioning a tubular having a drilling member in the wellbore;
disposing a one-way traveling plug in the tubular;
5 engaging the tubular with a gripping member on the one-way traveling plug;
and
locating cement in an annular area between the tubular and the wellbore.
- 10 2. The method of claim 1, further comprising forming the wellbore.
3. The method of claim 1, further comprising using the plug to separate the
cement and another fluid in the wellbore.
- 15 4. The method of claim 1, further comprising preventing cement in the annular
area from flowing into the tubular.
5. The method of claim 1, wherein the tubular comprises a casing.
- 20 6. The method of claim 1, wherein actuating the plug comprises providing a
pressure differential in the wellbore.
7. The method of claim 1, further comprising drilling through the plug.
- 25 8. The method of claim 7, wherein drilling through the plug is accomplished
using a second tubular having a drilling member disposed thereon.
9. A cementing plug for cementing a tubular in a wellbore, comprising:
a body;
30 one or more gripping members, wherein the gripping members, when
actuated, prevent movement of the body in a first axial direction relative to the

tubular, and, when not actuated, allow movement of the body in a second axial direction relative to the tubular; and

a biasing member disposed around the gripping members.

5 10. The cementing plug of claim 9, wherein the gripping members are actuatable by fluid pressure.

11. The plug of claim 9, wherein the plug further comprises a sealing member for sealing a fluid path between the body and the tubular.

10

12. The plug of claim 9, wherein the body defines a bore extending therethrough.

13. The plug of claim 12, wherein the plug further comprises a seal for sealing the bore.

15

14. The plug of claim 13, wherein the seal is selectively shearable.

15. The plug of claim 14, wherein the selectively shearable sealing member comprises a first surface having a first surface area and a second surface having a second surface area, wherein the first surface area is smaller than a second surface area such that the sealing member is shearable by two different pressures.

20

16. The plug of claim 13, wherein the plug further comprises a second sealing member for sealing a fluid path between the body and the tubular.

25

17. The plug of claim 9, wherein the body comprises a sloped portion for biasing the gripping members outward into contact with the tubular.

30

18. The plug of claim 17, further comprising a drag element for urging the gripping members along the sloped portion.

19. The plug of claim 9, further comprising a drag element for urging the gripping

members axially relative to the body.

20. The plug of claim 9, wherein the gripping members are radially expandable into contact with the casing.

5

21. The plug of claim 9, further comprising a valve disposed in the body.

22. The plug of claim 21, wherein the valve is a single direction valve.

10

23. The plug of claim 9, wherein the plug is selectively positionable within the casing.

15

24. The plug of claim 9, wherein the gripping members and the gripping elements may comprise a material selected from the group consisting of cast iron, aluminum, aluminum with a hard, anodized coating, a ceramic material, a composite material, and combinations thereof.

20

25. The plug of claim 9, wherein the gripping members comprises a hollowed out portion.

26. The plug of claim 9, wherein one or more castellations are disposed at a lower portion of the body.

25

27. The method of claim 1, wherein the gripping member, when actuated, prevent movement of a body of the plug in a first axial direction relative to the tubular, and, when not actuated, allow movement of the body of the plug in a second axial direction relative to the tubular.

30

28. The method of claim 1, wherein the gripping member is actuatable by fluid pressure.

29. The method of claim 1, wherein the plug further comprises a sealing member for sealing a fluid path between a body of the plug and the tubular.

30. The method of claim 1, wherein a body of the plug defines a bore extending
5 therethrough.

31. The method of claim 30, wherein the plug further comprises a seal for sealing the bore.

10 32. The method of claim 31, wherein the seal is selectively shearable.

33. The method of claim 32, wherein the selectively shearable sealing member comprises a first surface having a first surface area and a second surface having a second surface area, wherein the first surface area is smaller than a second surface
15 area such that the sealing member is shearable by two different pressures.

34. The method of claim 30, wherein the plug further comprises a second sealing member for sealing a fluid path between the body and the tubular.

20 35. The method of claim 1, wherein a body of the plug comprises a sloped portion for biasing the gripping members outward into contact with the tubular.

36. The method of claim 35, further comprising a drag element for urging the gripping members along the sloped portion.

25

37. The method of claim 1, further comprising a drag element for urging the gripping members axially relative to a body of the plug.

38. The method of claim 1, further comprising a biasing member disposed around
30 the gripping members.

39. The method of claim 1, wherein the gripping members are radially expandable into contact with the casing.

5 40. The method of claim 1, further comprising a valve disposed in a body of the plug.

41. The method of claim 40, wherein the valve is a single direction valve.

10 42. The method of claim 1, wherein the plug is selectively positionable within the casing.

15 43. The method of claim 1, wherein the gripping members may comprise a material selected from the group consisting of cast iron, aluminum, aluminum with a hard, anodized coating, a ceramic material, a composite material, and combinations thereof.

44. The method of claim 1, wherein the gripping members comprises a hollowed out portion.

20 45. The method of claim 1, wherein one or more castellations are disposed at a lower portion of a body of the plug.

25 46. A method of completing a wellbore, comprising:
positioning a tubular in the wellbore;
disposing a one-way traveling plug in the tubular;
engaging the tubular with a gripping member on the one-way traveling plug;
drilling through the one-way traveling plug; and
locating cement in an annular area between the tubular and the wellbore.

30 47. A method of installing a cement plug in a casing to cement the casing in a wellbore, comprising:
running the casing into the wellbore;
disposing the cement plug in the casing, the cement plug having

a body having a bore therethrough;
a gripping member for preventing axial movement of the body; and
a shearable seal member for blocking the bore;

measuring a hydrostatic head; and

5 activating the gripping members in response to the measured hydrostatic head to engage the casing, thereby installing the cement plug in the casing.

10 48. The method of claim 47, further comprising supplying cement in front of the plug and a fluid behind the plug, wherein the plug separates the fluid from the cement.

49. The method of claim 47, wherein activating the gripping members comprises expanding the gripping members into contact with the casing.

15 50. The method of claim 47, wherein activating the gripping members comprises urging the gripping members outward along a sloped portion of the body.

51. A plug for installation in a casing, the plug comprising:

a body having a bore therein;

20 one or more gripping members selectively actuatable for positioning the plug in the wellbore;

a shearable seal member disposed in the bore for blocking a fluid flow therethrough; and

a valve for controlling fluid flow through the bore.

25

52. The plug of claim 51, wherein the one or more gripping members grip the casing to prevent movement of the plug in a first axial direction relative to the casing but allow movement of the plug in a second axial direction relative to the casing.

30 53. The plug of claim 51, wherein the valve comprises a flapper valve.

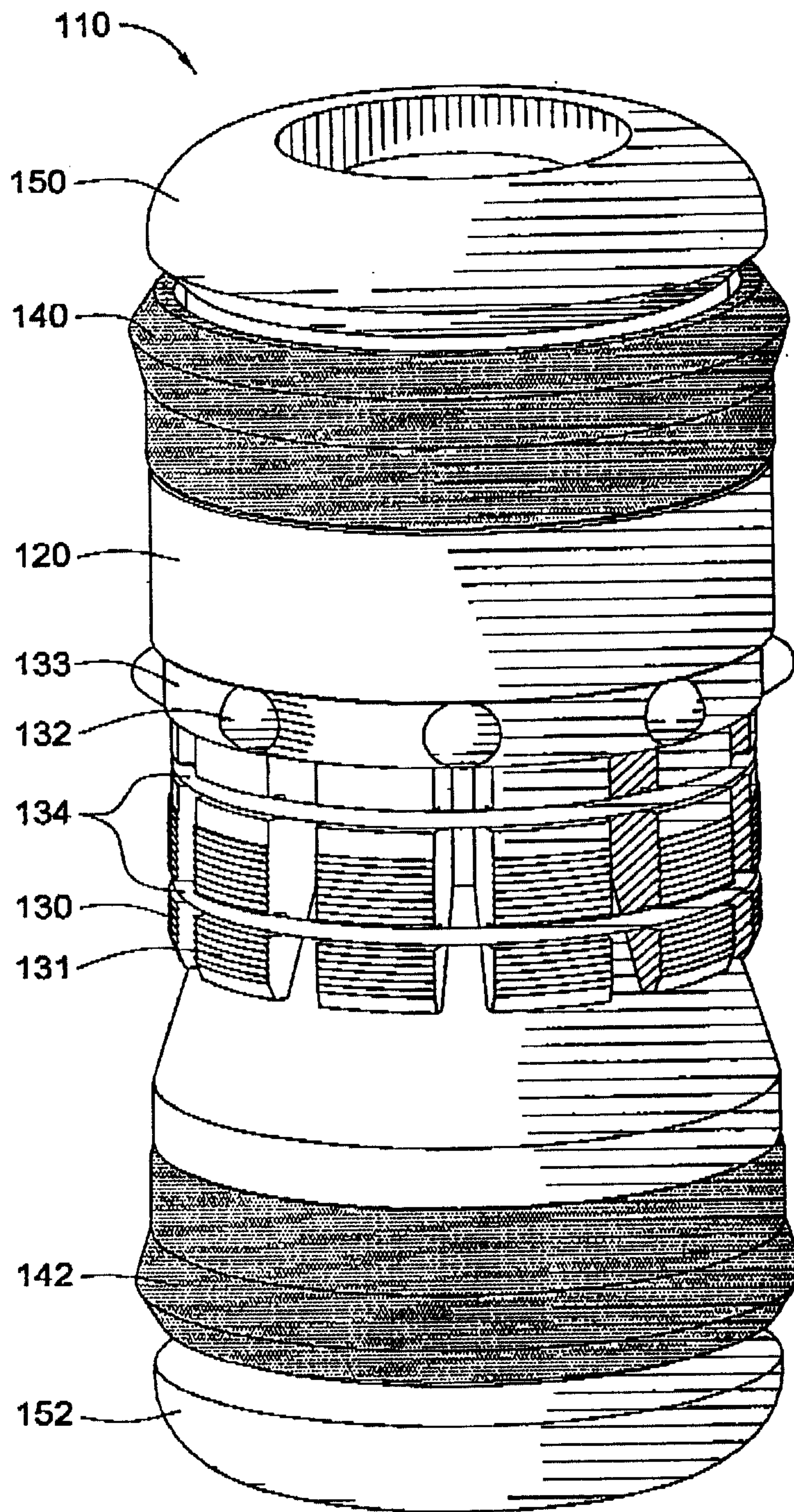
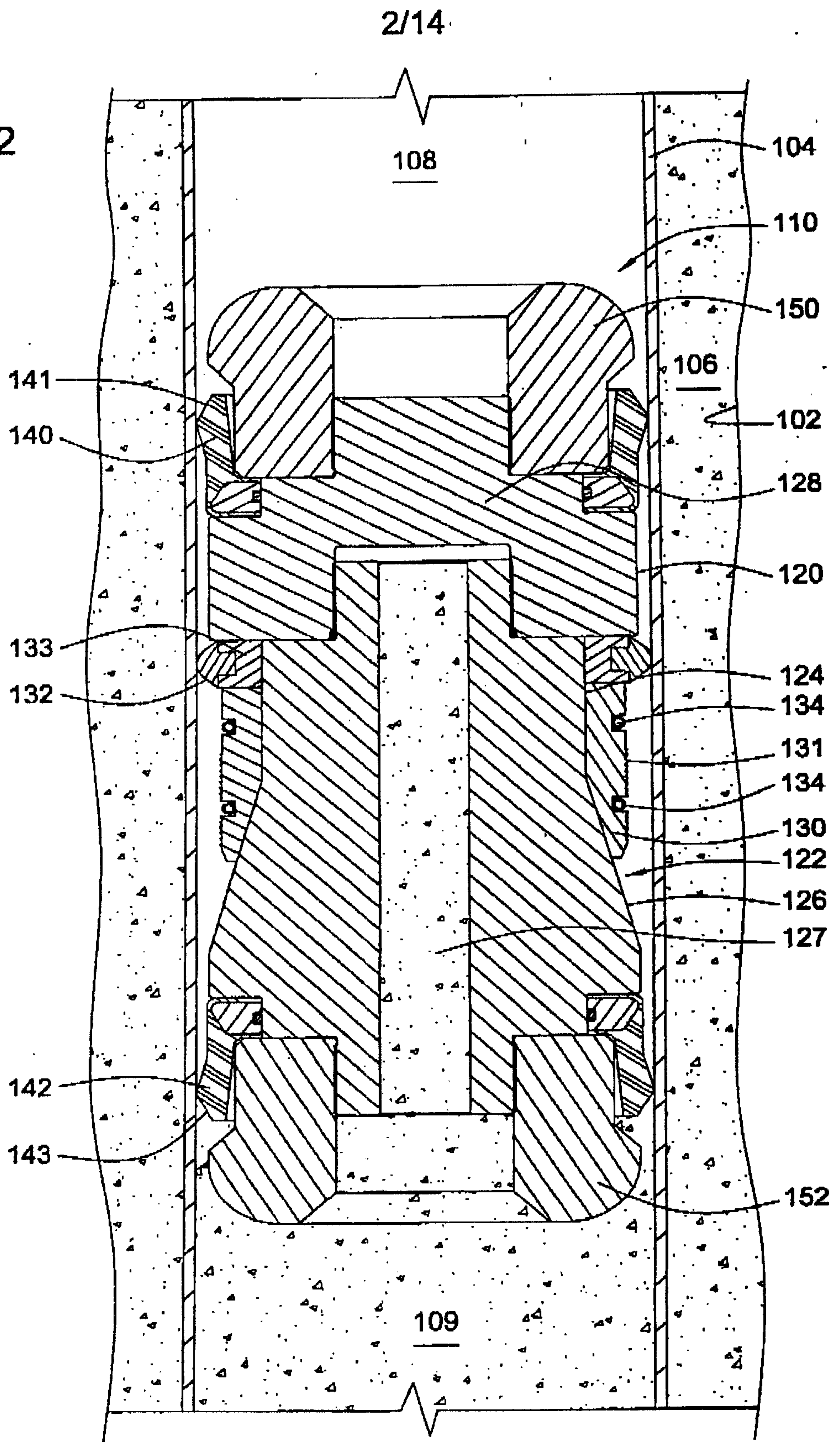

FIG. 1

FIG. 2



4/14

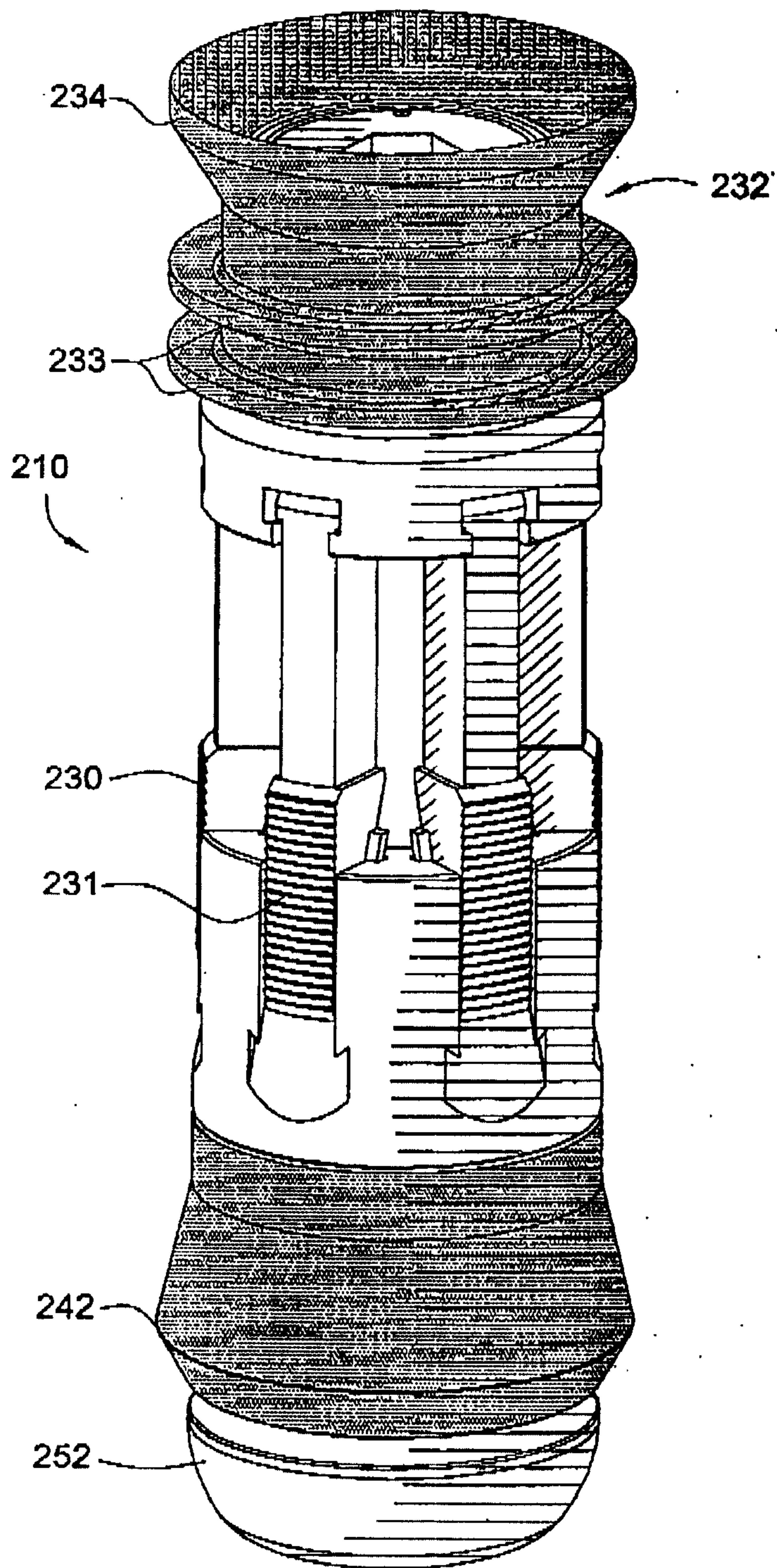

FIG. 4

5/14

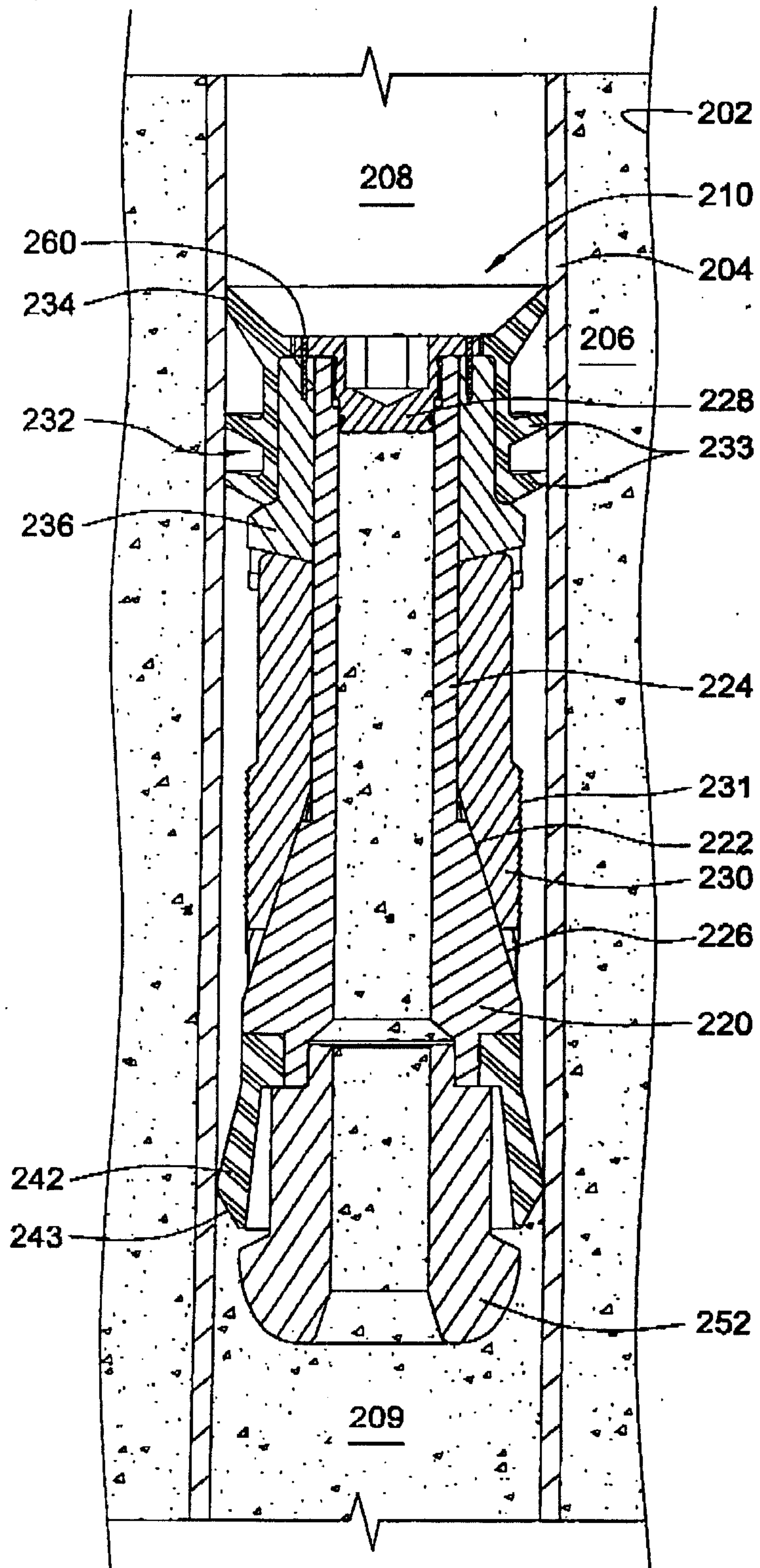

FIG. 5

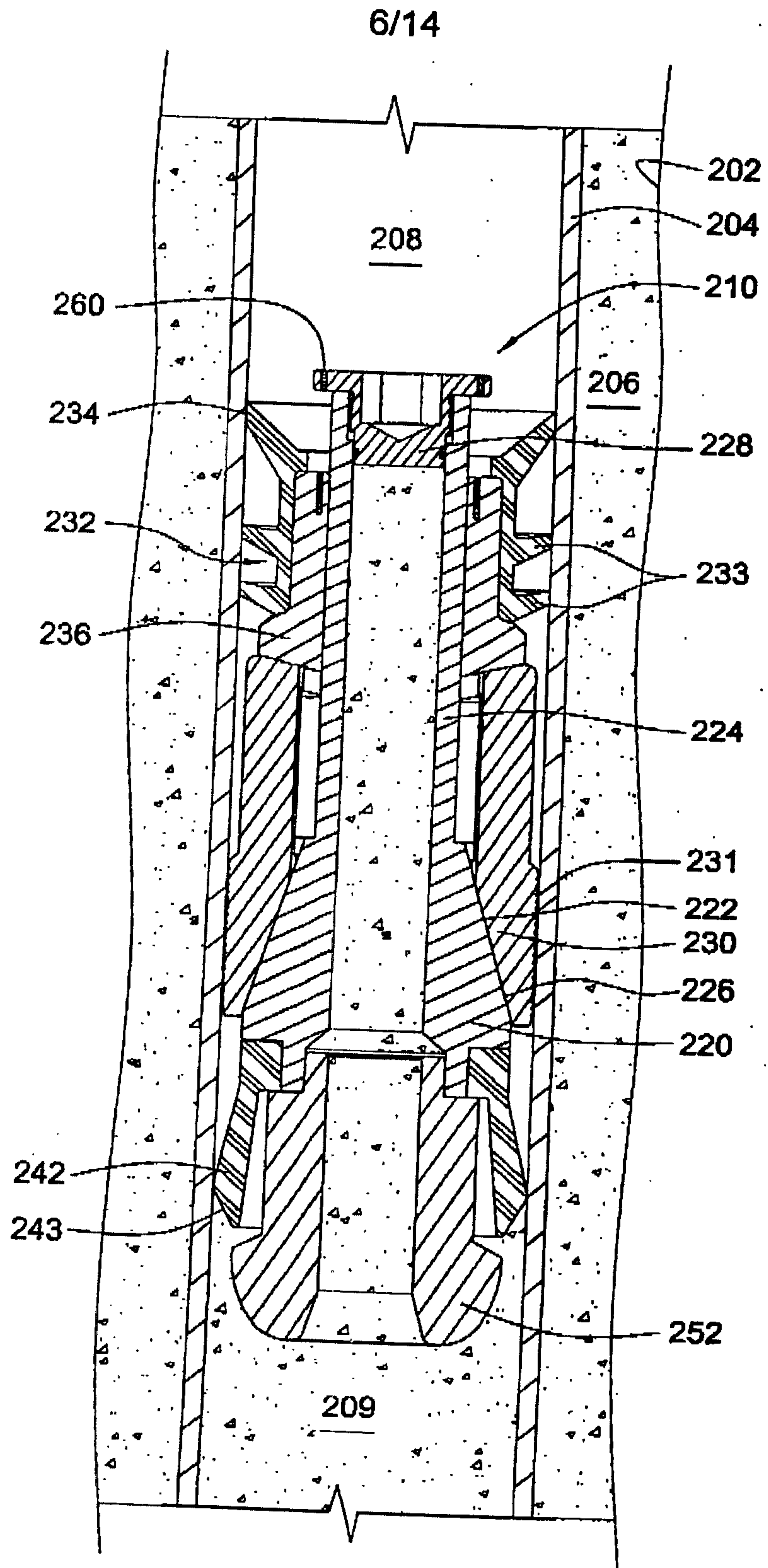

FIG. 6

FIG. 7

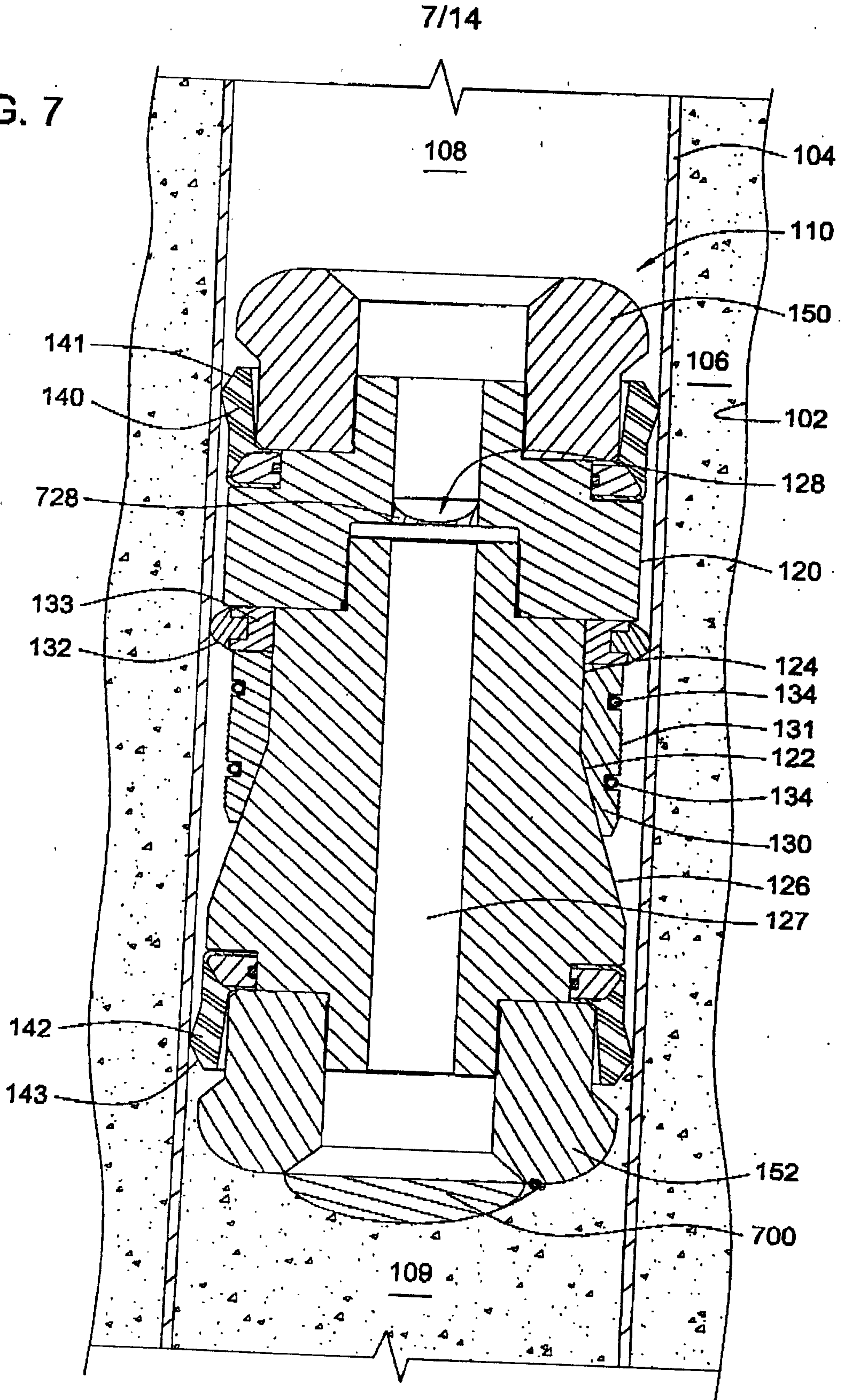
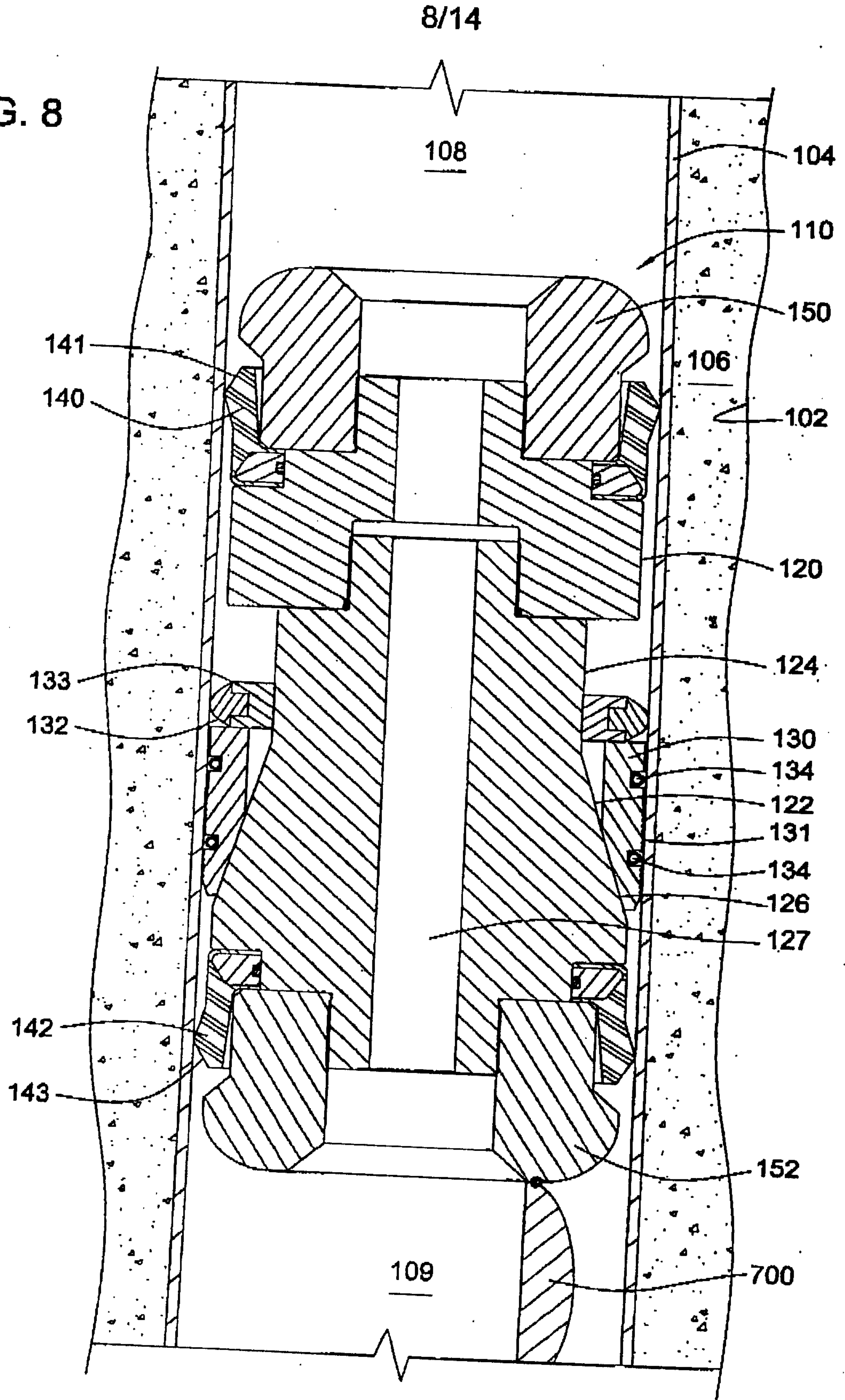
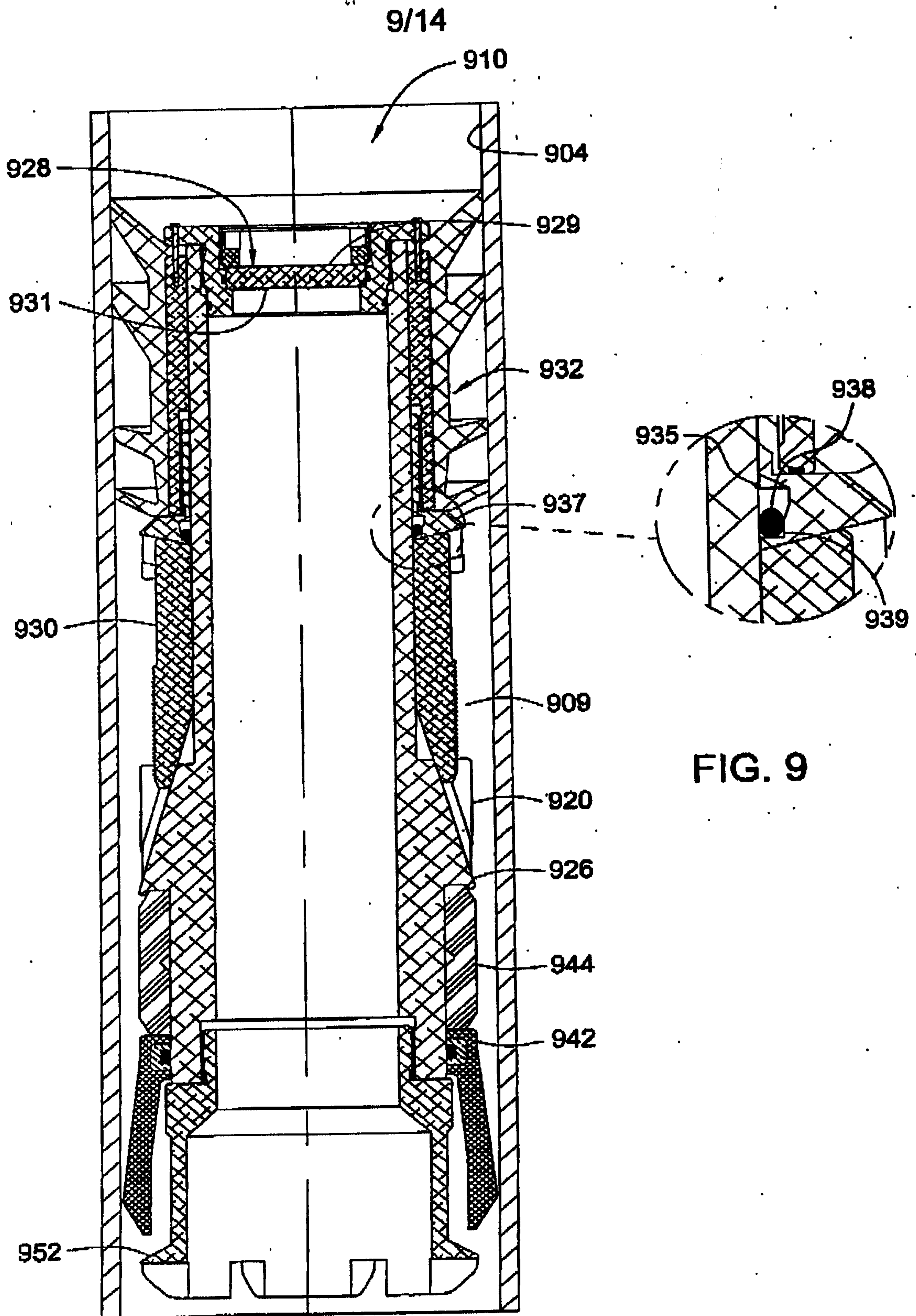
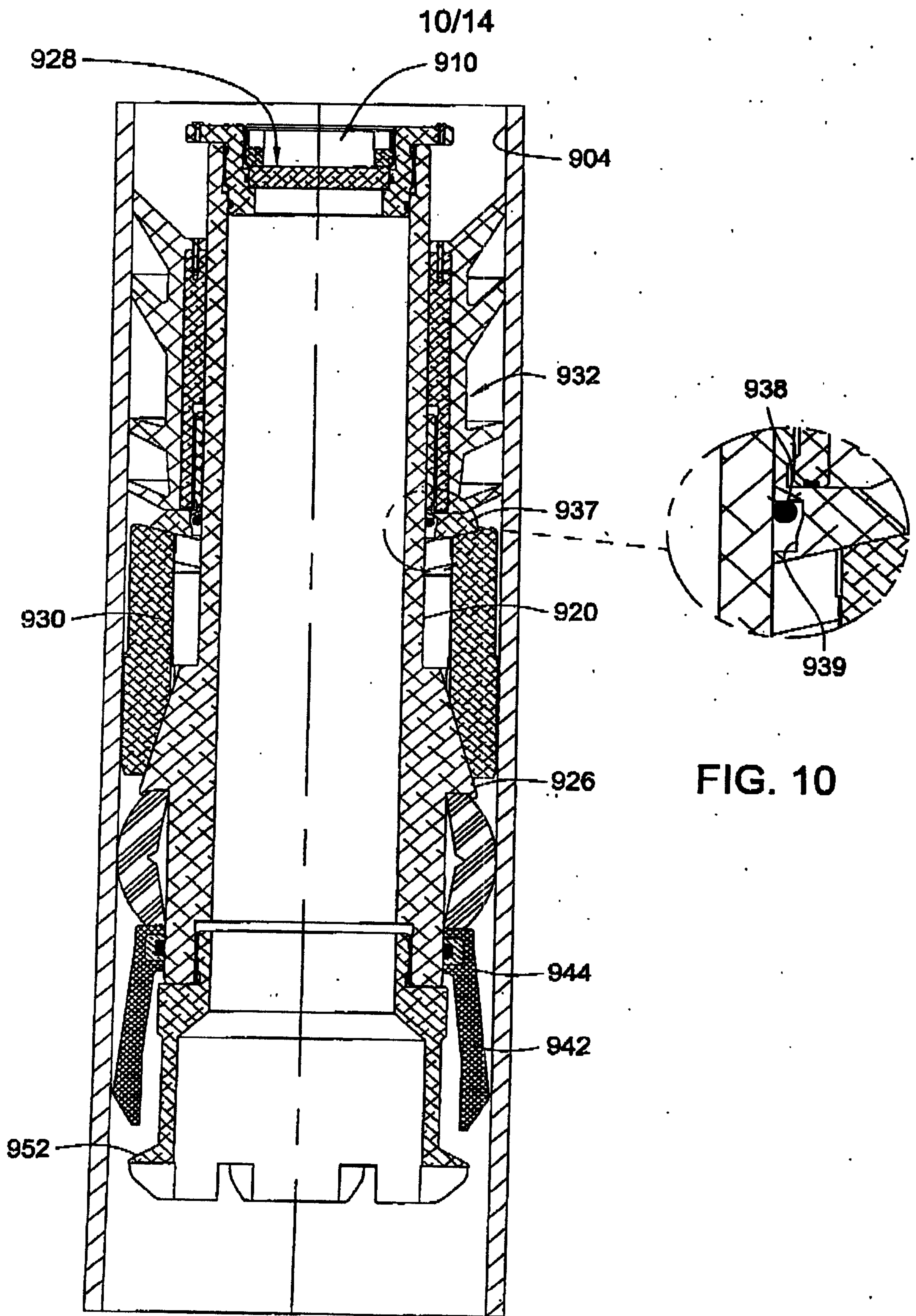

FIG. 8







11/14

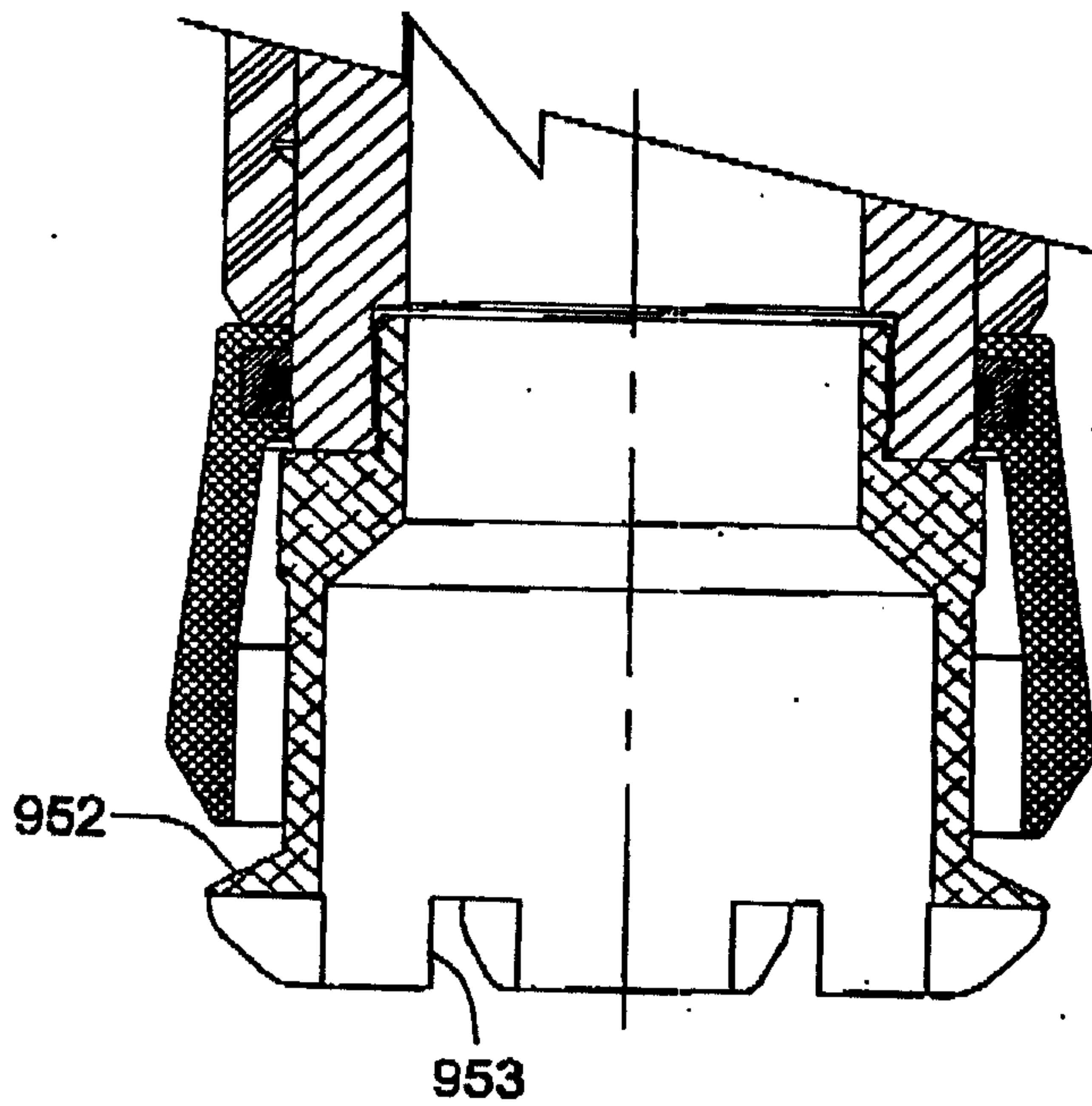

FIG. 11

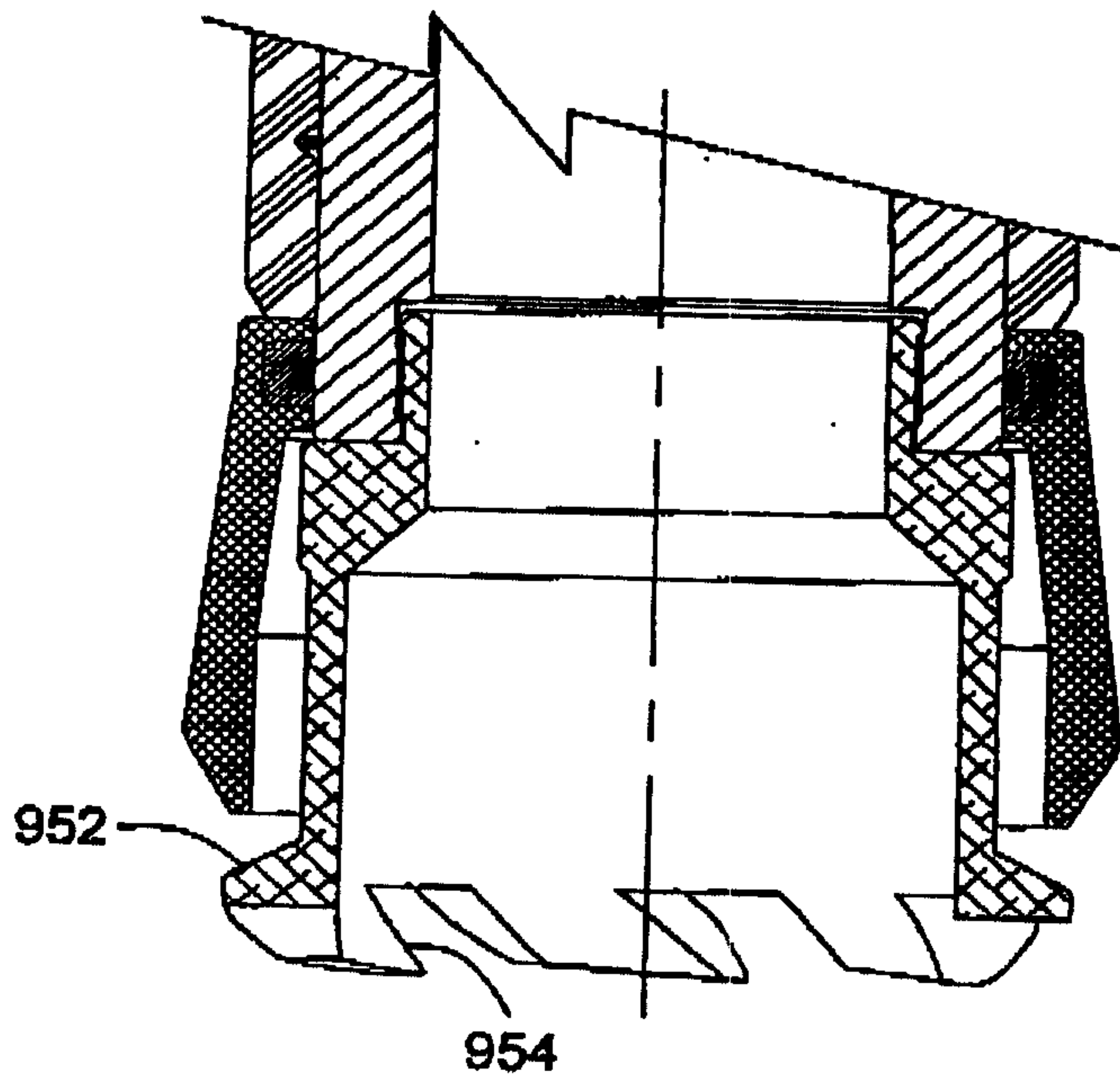

FIG. 12

12/14

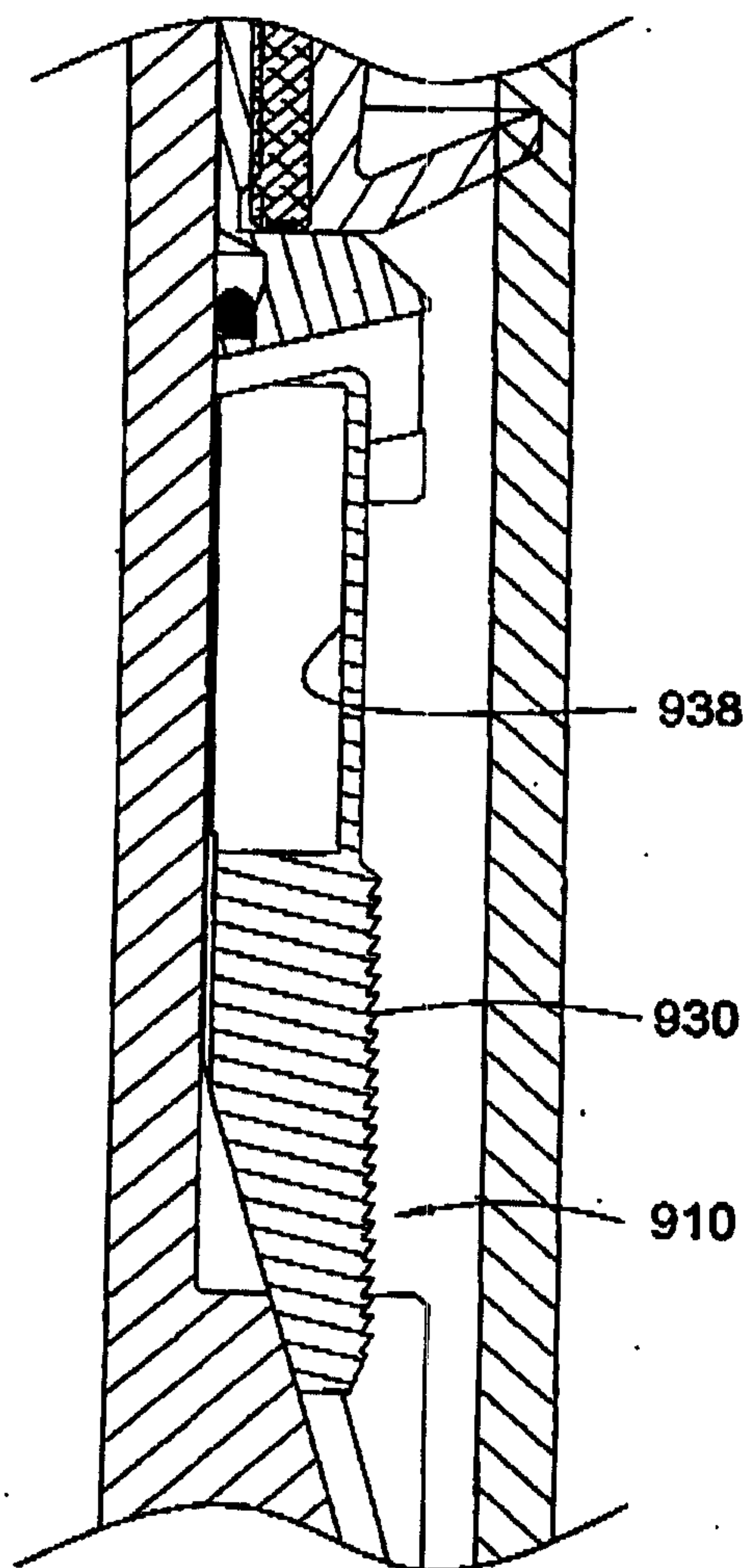
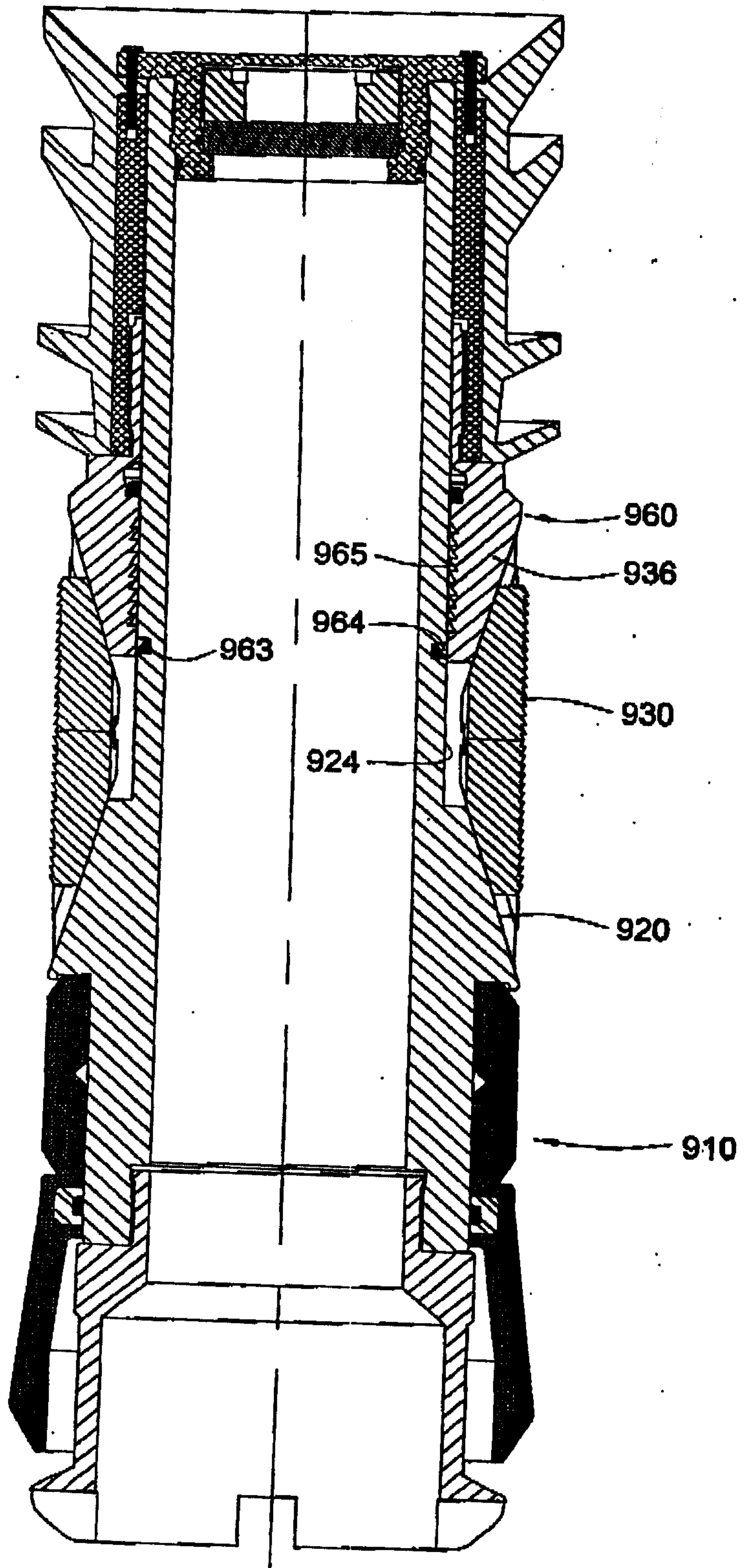

FIG. 13

13/14

FIG. 14



14/14

FIG. 15

