

(No Model.)

M. M. & J. C. CONGER.

MOTOR.

No. 250,787.

Patented Dec. 13, 1881.

Fig. 1.

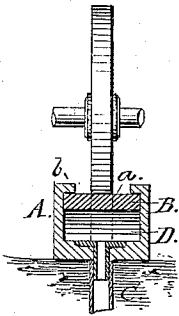

Fig. 2.

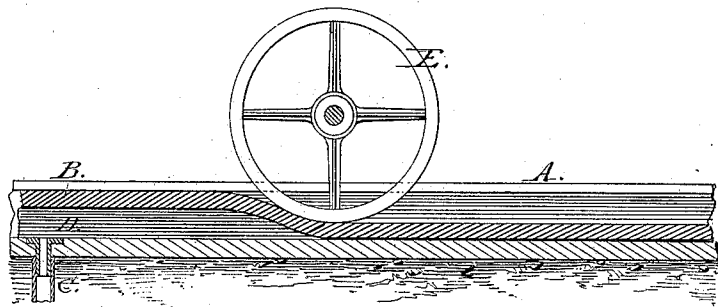

Fig. 3.

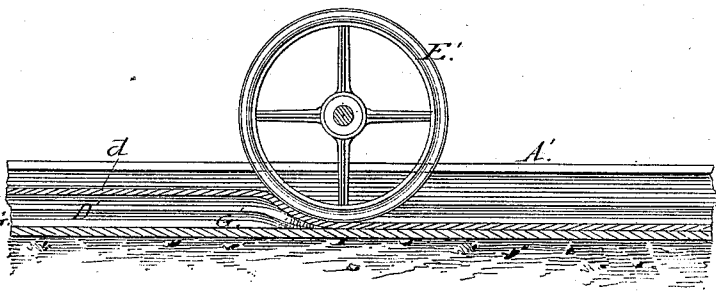
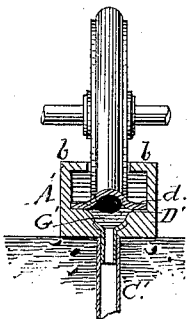
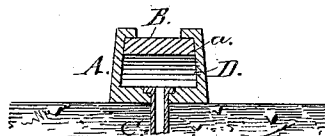

Fig. 5.



Witnesses:
E. H. Hickman,
J. N. Hall

Inventors:
Milton M. Conger and
Job C. Conger
per Edw W Down & Co. atty.

UNITED STATES PATENT OFFICE.

MILTON M. CONGER AND JOB C. CONGER, OF WELLSVILLE, MISSOURI.

MOTOR.

SPECIFICATION forming part of Letters Patent No. 250,787, dated December 13, 1881.

Application filed April 23, 1881. (No model.)

To all whom it may concern:

Be it known that we, MILTON M. CONGER and JOB C. CONGER, of Wellsville, in the county of Montgomery and State of Missouri, have invented certain new and useful Improvements in Motors for Impelling Vehicles and Machinery; and we do hereby declare that the following is a full, clear, and exact description of the invention, which will enable others skilled in the art to which it appertains to make and use the same, reference being had to the accompanying drawings, and to letters of reference marked thereon, which form a part of this specification.

Our present invention is an improvement upon a patent granted to Milton M. Conger, of Wellsville, Missouri; and it consists of a tube of metal or other suitable material, open on one side to form a track for a wheel, in which is fitted to a steam-tight joint a strip of elastic packing, which packing, together with the bottom of said tubular track or rail, serves the purpose of a receiving-tube for steam, compressed air, or other elastic fluid, the latter of which, when forced into one end of said receiving-tube, lifts said packing and forms immediately in rear of a wheel adapted to bear against the collapsed portion of said packing and receiving-tube an inclined abutment, to carry a weight superincumbent upon an axle of said wheel, or drive, from the momentum or force of said wheel, machinery of various kinds.

In our drawings, Figure 1 is a transverse section of the open tubular track or rail provided with a strip of packing. Fig. 2 is a longitudinal section of same. Fig. 3 is a transverse section, showing another form of receiving-tube, flexible in part. Fig. 4 is a longitudinal section of the same. Fig. 5 shows a variation in the form of the tube.

Similar reference-letters indicate like parts in all of the figures.

Referring to the drawings, A is the open track, rectangular in general form, composed of metal, preferably provided with a longitudinal opening, *a*, on one side, of a width sufficient to receive a vehicle-wheel or a driving-wheel.

B is a strip of elastic packing, which is fitted snugly between the upright walls, relatively so, of the tube A, sufficiently so to form a steam-tight joint as it (the said packing) is moved in said tube.

Beneath the tube A is a pipe or pipes, C, which conduct the fluid to said tube from the place where it is generated and into the space D, formed beneath said packing B. The elastic packing B runs the entire length of the tubular track, and its upper surface forms a bearing to the wheel E. The wheel E, with the weight it carries, when the tube or space D is collapsed, presses said packing B down until it rests upon the bottom of the open tubular track A. A jet of steam, compressed air, or other elastic fluid is let or forced into the pipes C, and thence into the space beneath the packing B, to lift said packing and form the tubular space D. The packing in this case answers the double purpose of the flexible ribbon and flexible tube shown and described in the patent previously referred to. A limit to the movement of the packing B is formed by the flanges *b b* of the tubular rail A, and an abutment, G, is formed against the periphery of the wheel E by the packing B under the pressure of the fluid against the said packing from underneath.

In Figs. 3 and 4 of our drawings is shown a variation in form only of the tubular track, which is constructed upon the principle of a tube, to receive compressed air, steam, or other fluid, formed with its sides rigid, except one, which is formed of flexible material. A longitudinal groove, G', in this second form is provided, and said groove is capped with gummed or oiled cloth *d*, firmly secured to the metallic base of the tube A', as shown in Fig. 3. The pipe C' discharges the fluid into the groove G' from beneath and lifts the prepared cloth or flexible fabric *d* to form the tube D'. The driving-wheel E', applicable in this variation, should have an annular projection on its periphery to correspond with the depression or groove G'. It would be an advantage to have the annular projection of the wheel E' formed of rubber or suitable flexible material, as with such the wear in the tread of the wheel would be greatly modified.

In the practical arrangement of our device it is contemplated to provide suitable means for exhausting or collapsing the space beneath the flexible bearing for the wheel.

While we prefer to have the open tubular track rectangular in form, in practice we might conclude to adopt the form of tube shown in

Fig. 5, with the upright or side walls inclined inward to facilitate the perfect packing of the joints on either side of the packing material.

5 The open tubular rail A, instead of being angular, as shown, may be of cylindrical or semi-cylindrical form.

Having thus described our invention, what we claim as new, and desire to secure by Letters Patent, is—

10 The tubular track provided with longitudinal flanges *b* and pipe C, in combination with

the flexible strip B, as and for the purpose specified.

In testimony that we claim the foregoing as our own we affix our signatures in presence 15 of two witnesses.

MILTON M. CONGER.
JOB C. CONGER.

Witnesses:

S. M. BARKER,
M. WASHINGTON.