

(19) (KR)
(12) (B1)

(51) 。 Int. Cl.7
G02F 1/1333

(45)
(11)
(24)

2004 06 12
10-0436181
2004 06 04

(21) 10-2002-0020724
(22) 2002 04 16

(65)
(43)

10-2003-0082144
2003 10 22

(73) 20

(72) 101-902

(74)
:

(54)

, , 3 가 ,

6

1
2

3a 3g 4a 4g 5a 5g 2 - \, - \, - \,

6

7a 7h 8a 8h 9a 9h 6 - \, - \, - \,

< >
100 : 110 :
112 : 114 :

129 : 2 132 :
 134 : 135 : 1
 136 : 138 :
 140 : 142 :
 146 : 148 :
 150 :

1
 (8) (11) (6) (7) (8) ,
 (56) (T) (9) (5) (P) (5)
 (22) (15) (22) (T)가 (matrix type)
 (P) (12) 가 (12) (34) (P)
 (56) - - (indium-tin-oxide : ITO)
 (T) (56)
 (12) (T) 1
 (34) (T) 2
 가 가 (15) (Spontaneous Polarization) 가
 가 (Bipolar) 가
 가
 2
 2
 (34) (12) (34) (P) (12)
 (36) (12) (10) (T)가 (34)
 (36) (58) (60)
 (34) (T) 가 (12) 가 (14) ,
 (14) 가 (40) (40) (42) (42) (32)
 (P) (42) (56)
 (56) (12) (12)
 (12) (56)
 (17) 1 2 1
 2 (28) () (C)
)
 (34) (32) (40,42) ()
 (34) (36) 1 (35) (28)

2 (29) . 4 , 4

3a 3g 4a 4g 5a 5g 2 - \ , - \ , - \

4 , 4a 4a 4g , 3a 4a 5a , 5a (22) 5g 1 .)

4) , (10) , (12) , (12) (1)

(Al), (Al) , (Mo), (W), (Cr) (Mo) (Cr)

(12) (10) (22) 1 (16) ,

(18) , (16) (20) 2 (24) .

1 (SiN_x) (Cr), (SiO₂) (Mo), (W), (Ta)

(24) (T) , (P) (S)

(D) (G) (P) (S)

3b 4b 5b (photo-resist: 'PR') PR (26) , PR (26)

(positive type) (A) (B) (C)

PR (26) (22) (A) (B) (C)

(50) (C) (14) (C)

PR (26) (50) (A) (exposure) , (devel

op) (34) (36) 1 (35) , (26)

3c 4d 5d (T) (S)

(D) PR (26) PR (26) 2 (3c 24)

3d 4d 5d (3c 20) (18)

(28) , (T) (D) / (28) , /

(12) (34) , (36) (38) (28)

(34) (36) 1 (35) , (26)

2 (29) (T) 1 (32) ,

(32) (30) (T) (CH)

3e 4e 5e PR (ashing processing)

PR (26) (F) 가 (14) (E) PR

PR (26) (28,38,36)

PR (26) (Mo) 가 , (Cr)

3f 4f 5f (T) / (32)

(CH) (40) (42) , (32)

(36)가 2 (32) (40,42) (34)

(40,42) (34) (22) (BC

B) (acryl) (resin) (46) (SiN_x) (SiO₂) 2 ,

(48) , (46) 3 , (42) (10) (36)
 (28) (50) , (54) (IT0) - -
 (52) , (46) 4 (56) ,
 3g 4g 5g (P) (28) (36)
 (IZO) (42) (10) (58) (60)

4

3

(n+a-Si:H) 2 가 PR 1 ; PR (a-Si:H) 1 ;
 ; ; 1 , 2 / ,
 / ; / ; 3
 ; ; 3 가 3
 ; 3

(SiN_x)

300 500 ~1000

(Cr), (Mo), (W), (Ta)

-- -- 3
 6 (112) (100) (112) (13) (P) ,
 (112) (136) (150) (110) (T)가 (134) (148)

(134) (T) (112) 가 (114) , (142)
 , (114) (140) (142) (132)
 , (P) (142) (146) ,
 (146) (112) (112) (138) ,
 , (146) (142) , (138)
 , (112) 1 , (146) 2
 (132) 2 () (C) .
 , 7a 7h 8a 8h 9a 9h 6 - , - , -
 7a 7h 8a 8h 9a 9h 6 - , - , -
 (7a 7h , 8a 8h , 9a 9h)
 7a 8a 9a , (100) (Al), (W), (Mo), (Cr)
 , (114) 1 (112) (110)
 , (114) RC (delay)
 (hillock)
 , 가 (112) (114) (116)가 (100) (Acryl)
 (SiO₂), (SiN_x) (116) (a-Si:H)(118) (BCB)
 H)(120) 2 2 (124) (Cr), (Mo), (W), (Ta) (n+a-Si:
 , (D) 2 (124) (100) (P) , (T) (S)
 , 7b 8b 9b , 2 (124) (100) ()
 photo-resist: 'PR') PR (126) (150)
 PR (126) (100) (A) (B) () (C) (C)
 , (114) (150) (exposure) , (develop)
 , 7c 8c 9c , (D) PR (126) PR (126)
 , , 7d 8d 9d , PR (126) 2 (7c (7
 124) (7c 120) (D) / (136)
 128) , / (128) (134) , (138)
 , (112) (138) (128)
 (134) (136) 1 (135) , (138)
 , 2 (129) 1 (132) ,
 (132) (T) 1 (130) (116)
 , PR (126) 1 (116)
 , 7e 8e 9e , (T) (CH)
 PR (ashing processing)

(114) (E) PR
 , PR (126) (F) 가 (128,138,136) .
 , PR (126) (Mo) , (Cr)
 PR ,
 , 7f 8f 9f (T) /
 132) , (140) (142) , ()
 2 , (132) (140,142) (134)
 (136) 2 - - (ITO) - -
 (IZO) (142)
 (P) (138) (146) , (110)
 (148) , (136)
 (150) .
 (146,148,150) (100) (SiN_x) (SiO₂)
 2 (152) 300 500 ~
 1000 , (146,148,150) 2 (152)
 (132) , 7g 8g 9g (152) (100) ()
 D) (G) (154) (printing) .
 , (polyimide) (152) , 7h 8h 9h ,
 , (148) (150) (S,T,P) 2 (154)
 (G) (D)
 , 3
 , 3
 , 가 .

(57)

1.

1 , ;
 ;
 PR (n+a-Si:H) 2 가 PR 1 (a-Si:H) ;
 ;
 ;
 1 ; 2 , / , / ;
 / / ;
 ;

3

가

3

3

3

2.

1

3.

1

4.

1

5.

1

가

6.

1

(SiN_x)

7.

6

300 500 ~1000

8.

1

9.

8

10.

1

(Cr), (Mo), (W), (Ta)

11.

1

/

1

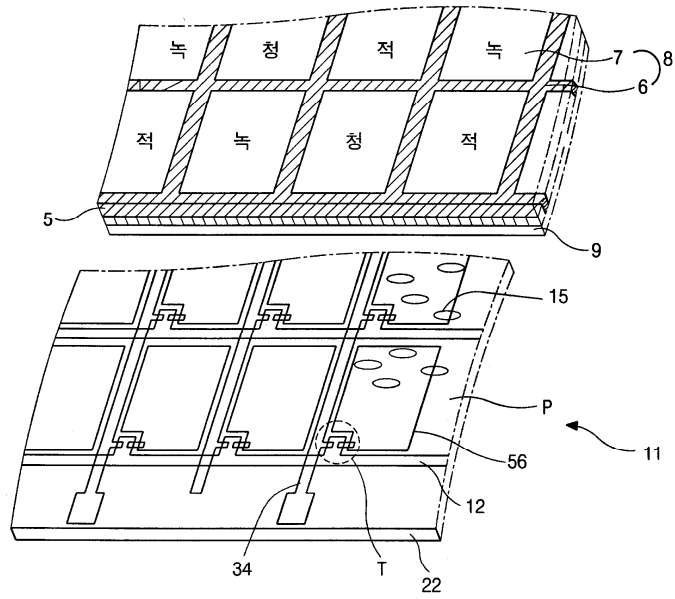

2

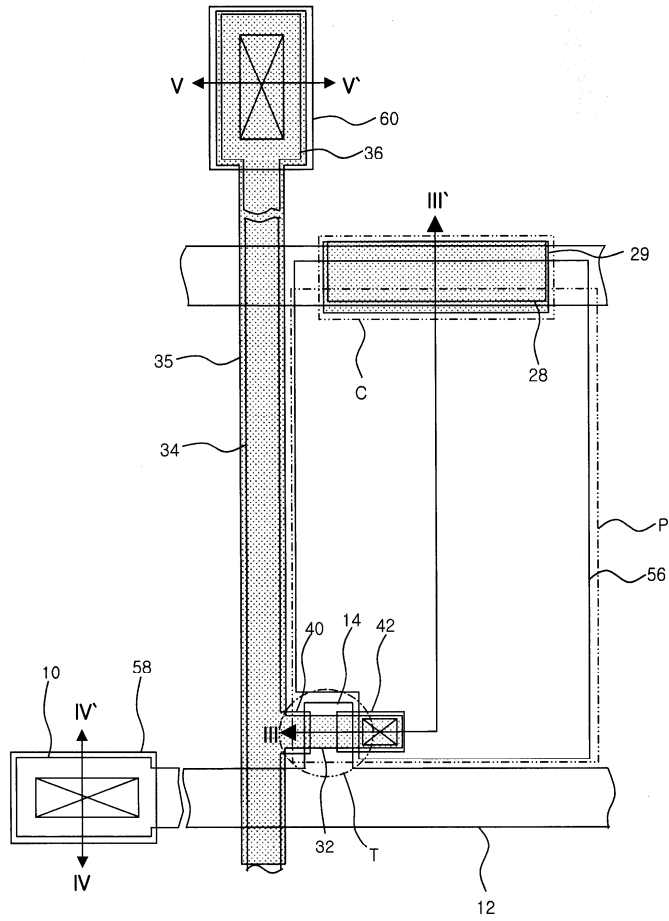

3a

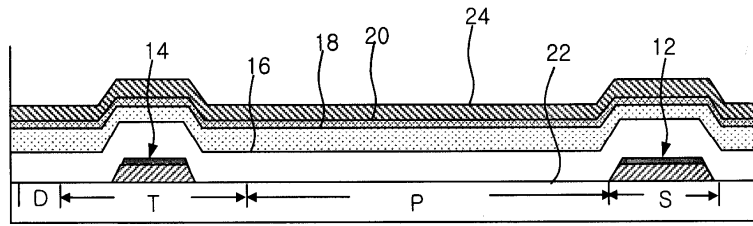

3b

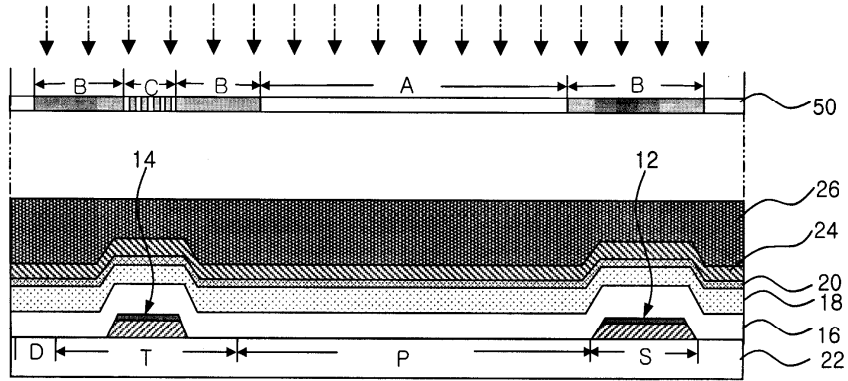

3c

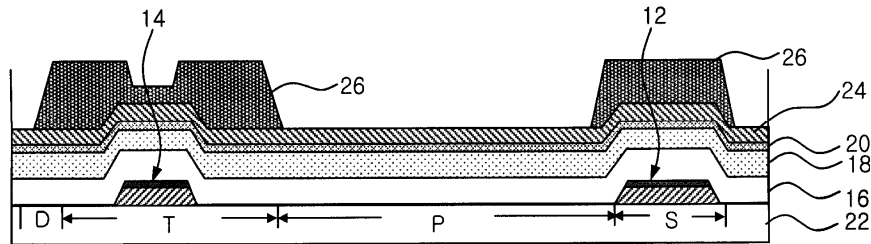

3d

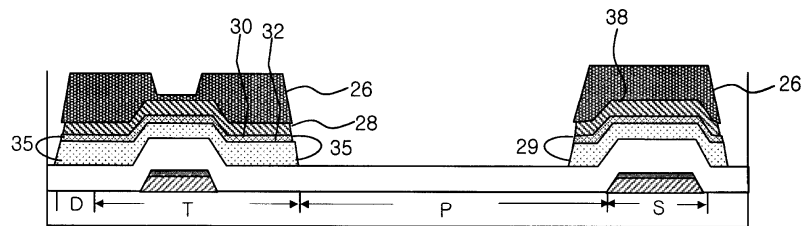

3e

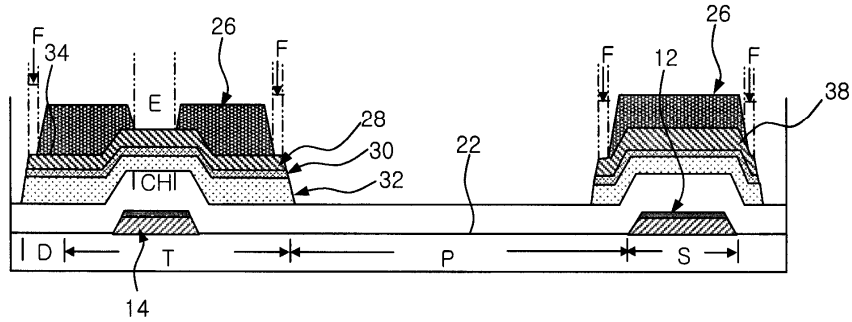

3f

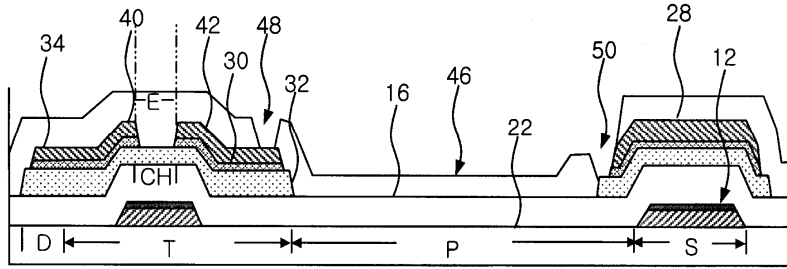

3g

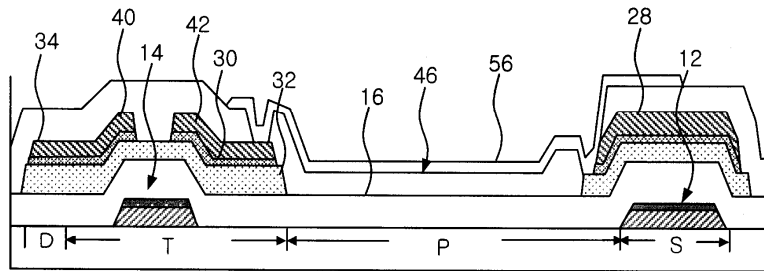

4a

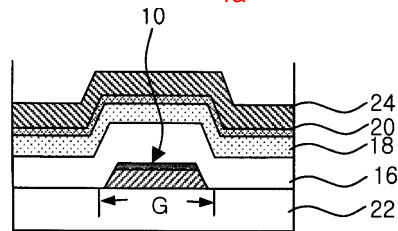

4b

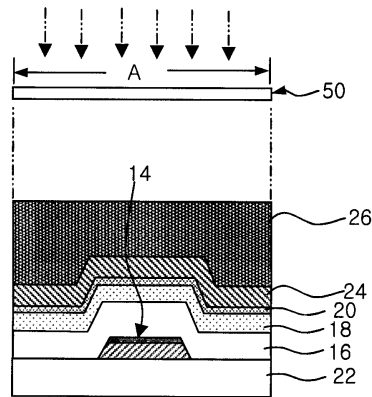

4c

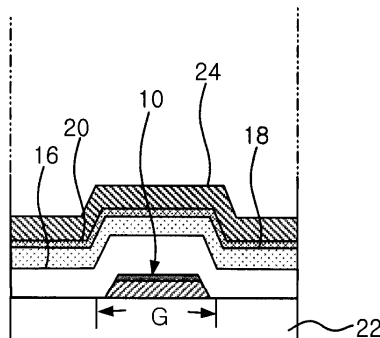

4d

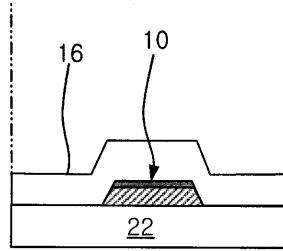

4e

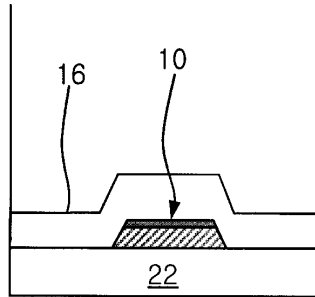

4f

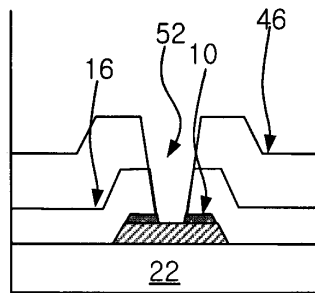

4g

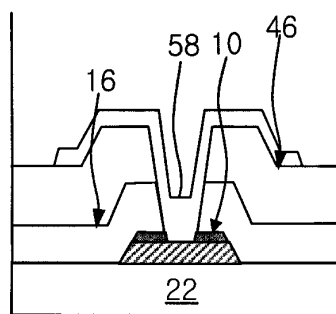

5a

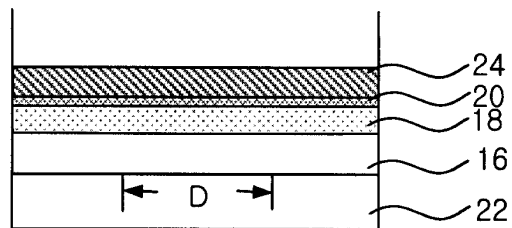

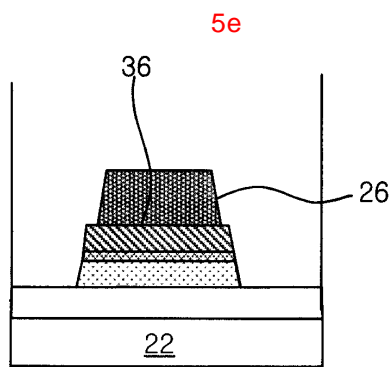
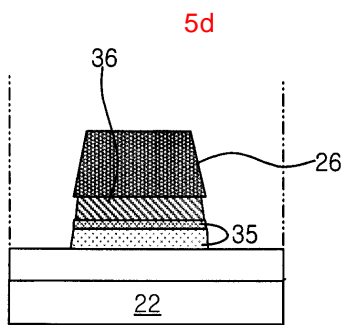
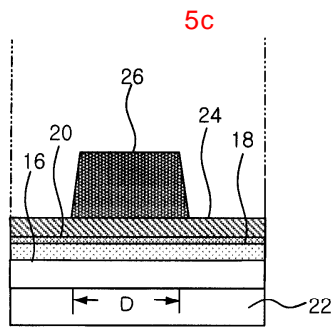
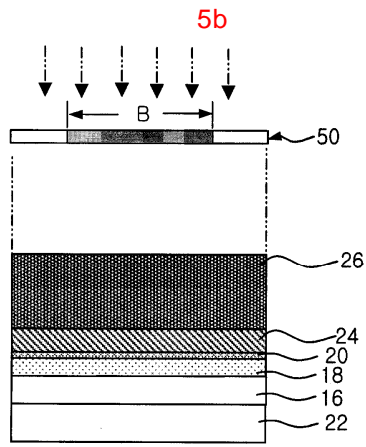

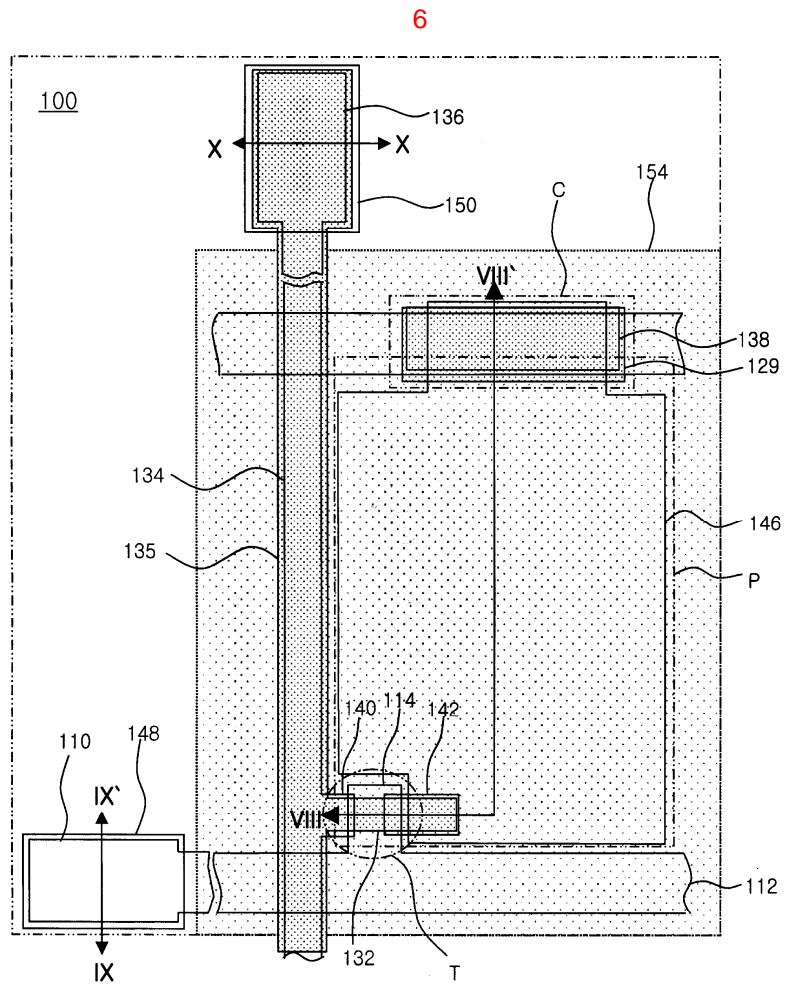
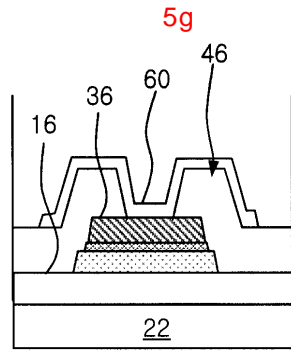
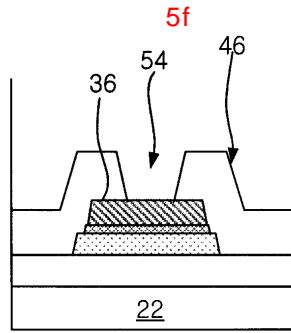

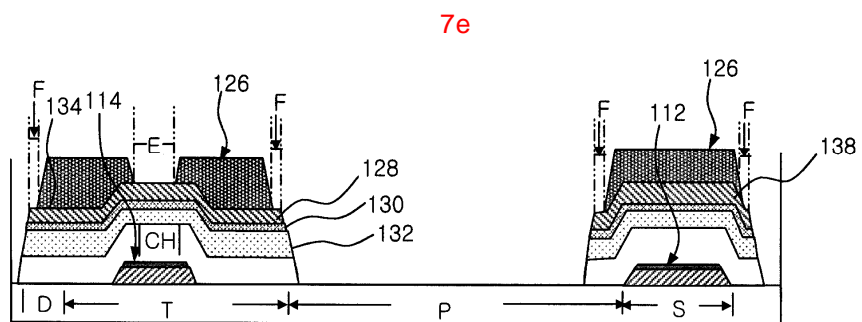
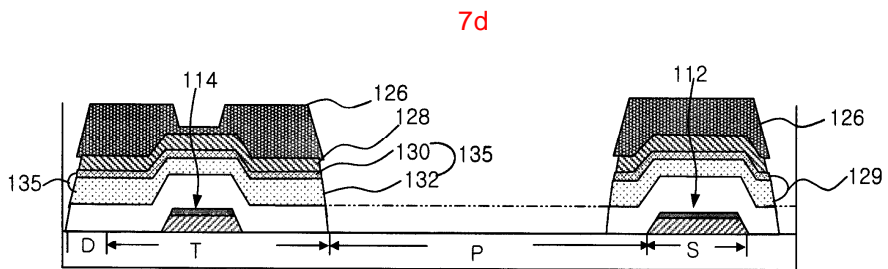
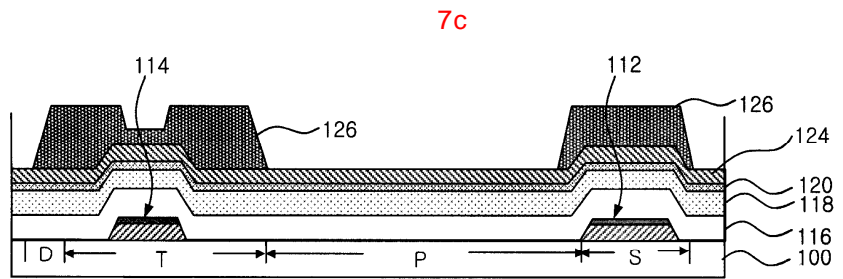
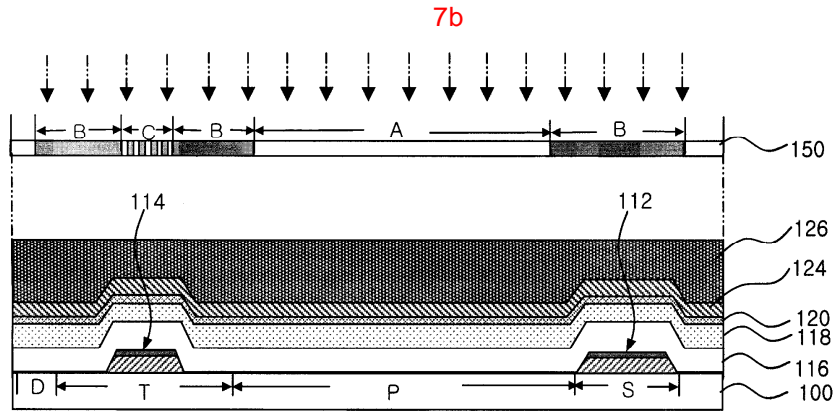
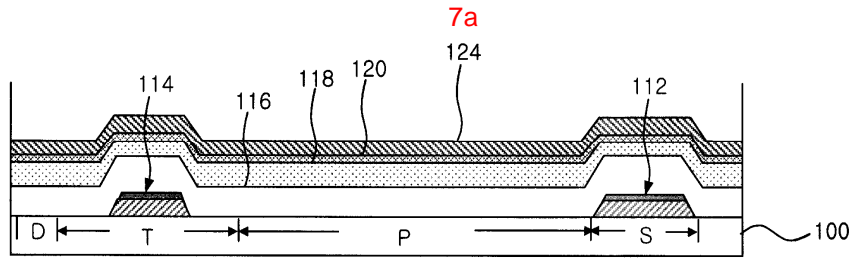

7f

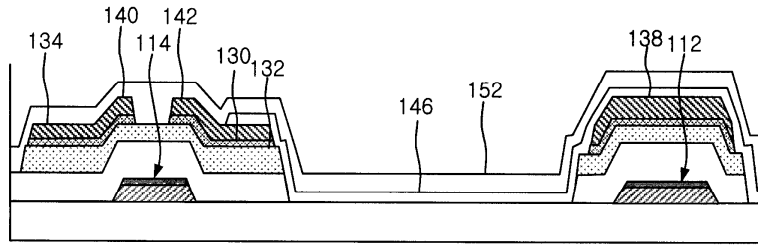

7g

건식식각

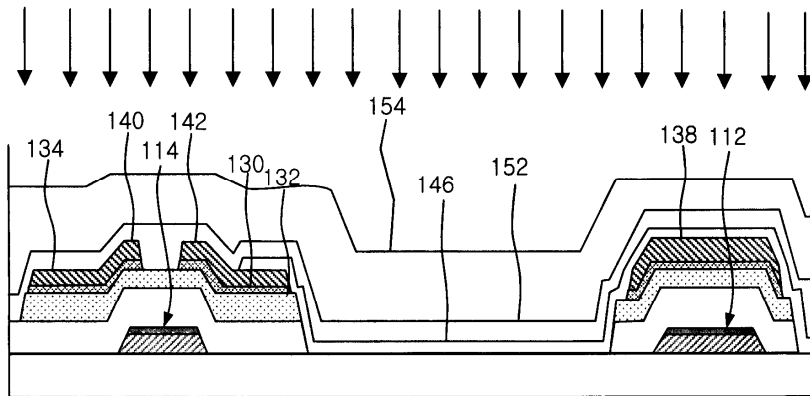

7h

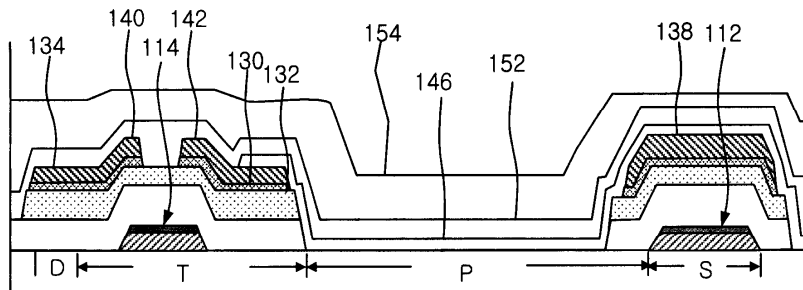

8a

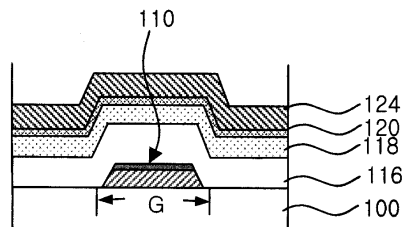

8b

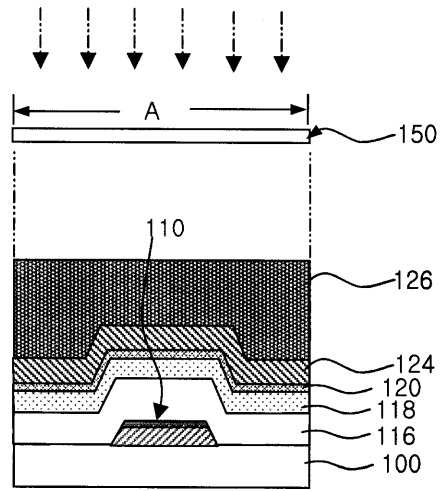

8c

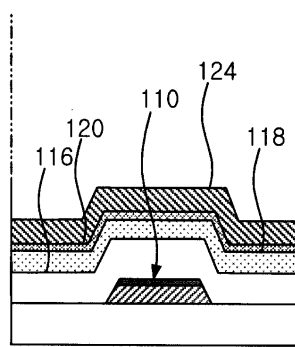

8d

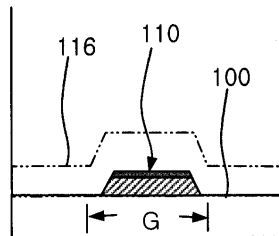

8e

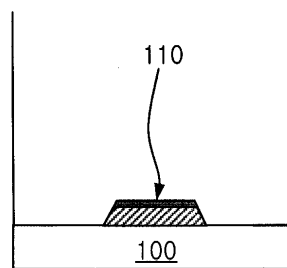

8f

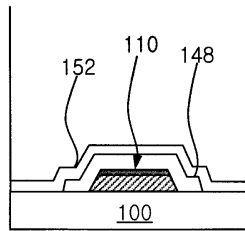

8g

건식식각

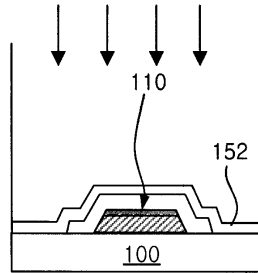

8h

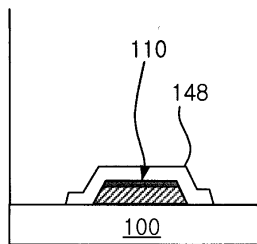

9a

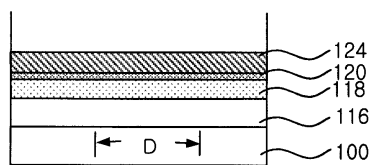

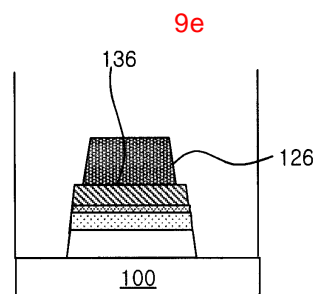
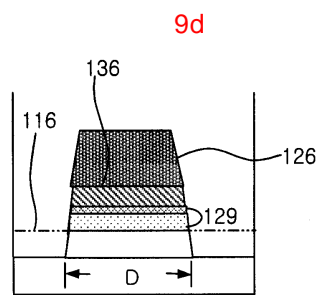
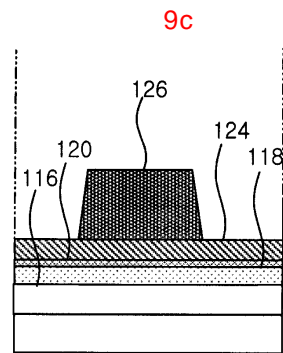
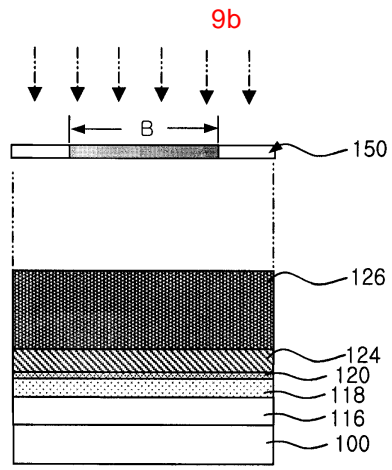

9f

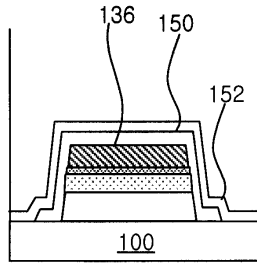

9g

건식식각

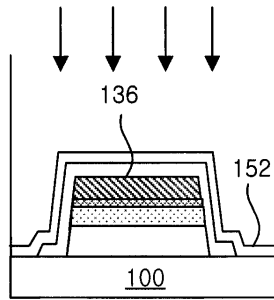

9h

