

(19) World Intellectual Property
Organization
International Bureau



(43) International Publication Date
3 June 2004 (03.06.2004)

PCT

(10) International Publication Number
WO 2004/045393 A2

- (51) International Patent Classification⁷: **A61B** [US/US]; 2029 Crist Drive, Los Altos, CA 94024 (US).
SHIU, Brian, K. [US/US]; 607 Arcadia Terrace #304, Sunnysvale, CA 94085 (US). **HOLMGREN, Neil** [US/US]; 6211 N. Winthrop Ave. #605, Chicago, IL 60660 (US).
- (21) International Application Number: PCT/US2003/037500
- (22) International Filing Date: 20 November 2003 (20.11.2003) (74) Agent: **LEVINE, David, A.**; P.O. Box 61180, Palo Alto, CA 94306-1180 (US).
- (25) Filing Language: English (81) Designated States (*national*): AE, AG, AL, AM, AT, AU, AZ, BA, BB, BG, BR, BW, BY, BZ, CA, CH, CN, CO, CR, CU, CZ, DE, DK, DM, DZ, EC, EE, EG, ES, FI, GB, GD, GE, GH, GM, HR, HU, ID, IL, IN, IS, JP, KE, KG, KP, KR, KZ, LC, LK, LR, LS, LT, LU, LV, MA, MD, MG, MK, MN, MW, MX, MZ, NI, NO, NZ, OM, PG, PH, PL, PT, RO, RU, SC, SD, SE, SG, SK, SL, SY, TJ, TM, TN, TR, TT, TZ, UA, UG, US, UZ, VC, VN, YU, ZA, ZM, ZW.
- (26) Publication Language: English
- (30) Priority Data: 10/301,061 20 November 2002 (20.11.2002) US (71) Applicant (*for all designated States except US*): **FOGARTY, Thomas, J.** [US/US]; 3270 Alpine Road, Portola Valley, CA 94028 (US).
- (72) Inventors; and (84) Designated States (*regional*): ARIPO patent (BW, GH, GM, KE, LS, MW, MZ, SD, SL, SZ, TZ, UG, ZM, ZW), Eurasian patent (AM, AZ, BY, KG, KZ, MD, RU, TJ, TM),
- (75) Inventors/Applicants (*for US only*): **KIM, Steven, W.**

[Continued on next page]

(54) Title: DEVICES AND METHODS FOR TREATMENT OF VASCULAR ANEURYSMS

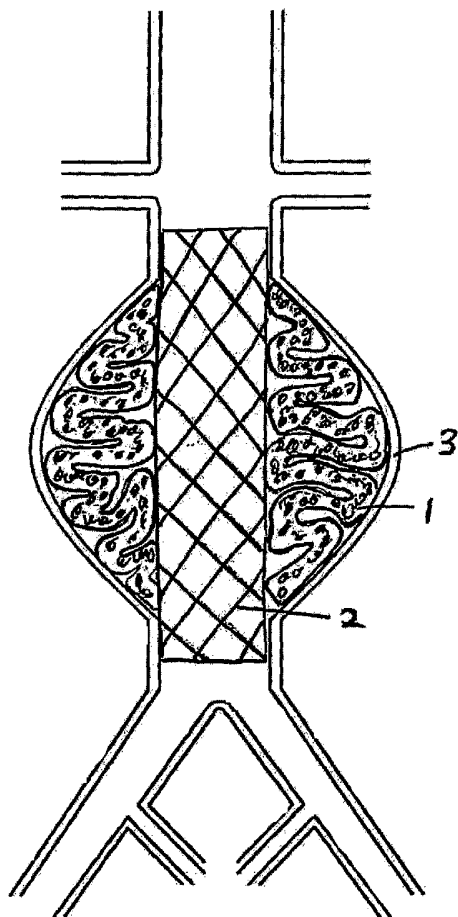

(57) Abstract: Devices and methods for the treatment of diseases in the vasculature, and more specifically, devices and methods for treatment of aneurysms (3) found in blood vessels are disclosed. In a first embodiment of the present invention, a two part prostheses, where one part is an expandable sponge structure (1) and the other part is an expandable tubular mesh structure (2), is provided. In the first embodiment, the expandable sponge structure (1) is intended to fill the aneurysm cavity (3) to prevent further dilatation of the vessel wall by creating a buffer or barrier between the pressurized pulsating blood flow and the thinning vessel wall. In the first embodiment, the expandable tubular mesh structure (2) is placed across the aneurysm (3), contacting the inner wall of healthy vessel proximal and distal to the aneurysm (3).

WO 2004/045393 A2



European patent (AT, BE, BG, CH, CY, CZ, DE, DK, EE, ES, FI, FR, GB, GR, HU, IE, IT, LU, MC, NL, PT, RO, SE, SI, SK, TR), OAPI patent (BF, BJ, CF, CG, CI, CM, GA, GN, GQ, GW, ML, MR, NE, SN, TD, TG).

For two-letter codes and other abbreviations, refer to the "Guidance Notes on Codes and Abbreviations" appearing at the beginning of each regular issue of the PCT Gazette.

Published:

— *without international search report and to be republished upon receipt of that report*

TJF 9004 - PCT

1
2
3
4
5
6
7
8
9
10
11
12
13
14
15
16
17
18
19
20
21
22
23
24
25
26
27
28
29
30
31
32

TITLE OF THE INVENTION

**DEVICES AND METHODS FOR TREATMENT
OF VASCULAR ANEURYSMS**

TECHNICAL FIELD AND BACKGROUND ART

[0001] The present invention relates to devices and methods for the treatment of diseases in the vasculature, and more specifically, devices and methods for treatment of aneurysms found in blood vessels. Aneurysms can occur in various areas of the cardiovascular system, but are commonly found in the abdominal aorta, thoracic aorta, and cerebral vessels. Aneurysms are unusual ballooning of the vessel due to loss of strength and/or elasticity of the vessel wall. With the constant pulsating pressure exerted on the vessel wall, the diseased or weakened wall can expand out and potentially rupture, which frequently leads to fatality. Prior methods of treating aneurysms have consisted of invasive surgical techniques. The technique involves a major cut down to access the vessel, and the diseased portion of the vessel is replaced by a synthetic tubular graft. Accordingly, this invasive surgical procedure has high mortality and morbidity rates.

[0002] Due to the inherent risks and complexities of the surgical procedures, various attempts have been made to develop minimally invasive methods to treat these aneurysms. For treatment of abdominal and thoracic aortic aneurysms, most of the attempts are catheter-based delivery of an endoluminal synthetic graft with some metallic structural member integrated into the graft, commonly called stent-grafts. One of the primary deficiencies of these systems is durability of these implants. Because catheter-based delivery creates limitations on size and structure of the implant that you can deliver to the target site, very thin synthetic grafts are attached to metallic structures, where constant interaction between the two with every heartbeat can cause wear on the graft. Also, the metallic structures often see significant cyclical loads from the pulsating blood, which can lead to fatigue failure of the metallic structure. The combination of a thin fragile graft with a metallic structure without infinite life capabilities can lead to implant failure and can ultimately lead to a fatality.

TJF 9004 - PCT

1 [0003] While the above methods have shown some promise with regard to treating
2 aortic aneurysms with minimally invasive techniques, there remains a need for a
3 treatment system which doesn't rely on the less than optimal combination of a thin
4 graft and metallic structural member to provide long-term positive results. The
5 present invention describes various embodiments and methods to address the
6 shortcomings of current minimally invasive devices and to meet clinical needs.

7

8

DISCLOSURE OF INVENTION

9 [0004] In a first aspect, the present invention provides a two part prostheses where
10 one part is an expandable sponge structure and the other part is an expandable tubular
11 mesh structure. The expandable sponge structure is intended to fill the aneurysm
12 cavity to prevent further dilatation of the vessel wall by creating a buffer or barrier
13 between the pressurized pulsating blood flow and the thinning vessel wall. The
14 expandable tubular mesh structure, which is placed across the aneurysm contacting
15 the inner wall of healthy vessel proximal and distal to the aneurysm, serves two
16 purposes. One, it defines the newly formed vessel lumen, even though it does not by
17 itself provide a fluid barrier between the blood flow and the aneurysm. Two, it keeps
18 the expandable sponge structure from protruding out of the aneurysm and into the
19 newly formed vessel lumen. The expandable tubular mesh structure is delivered first
20 across the aneurysm. Then, the expandable sponge structure is delivered via a
21 catheter-based delivery system through a "cell" of the tubular mesh structure and into
22 the aneurysm sac. When the sponge structure is deployed into the aneurysm sac and
23 comes in contact with fluid, it will expand to a size larger than the largest opening or
24 cell of the tubular mesh structure as to prevent the sponge structure from getting out
25 of the aneurysm sac. The filled aneurysm sac will most likely clot off and prevent
26 further dilation of the aneurysm and subsequent rupture. The blood flow should
27 maintain a natural lumen where the luminal diameter is approximately defined by the
28 diameter of the tubular mesh structure. The advantage of this system is that the
29 sponge filler material acts like a graft but has unparalleled durability. The metallic
30 structure can be optimized for durability as well because the size constraint is
31 somewhat relieved due to the absence of an integrated graft material, which takes up a
32 significant amount of space in a catheter.

TJF 9004 - PCT

1 [0005] In addition, the expandable sponge structure can be used to repair existing
2 endoluminal stent-grafts which have developed leaks. There are thousands of
3 endoluminal stent-grafts implanted into humans to treat abdominal aortic aneurysms.
4 That number is growing daily. The endoluminal stent-grafts are intended to exclude
5 the aneurysm from blood flow and blood pressure by placing a minimally porous graft
6 supported fully or partially by metallic structural members, typically called stents.
7 The acute success rate of these devices is very high, but there are a significant number
8 of these which develop leaks, or blood flow/pressure re-entering the aneurysm sac,
9 some time after the procedure. If the source of the leak can be accessed by the
10 delivery system, the expandable sponge structure can be deployed through that access
11 point.

12 [0006] In another aspect, the present invention provides an inflatable tubular balloon
13 graft. It is a tubular graft, straight or bifurcated, where its wall is not a solid structure
14 but a hollow chamber. The chamber can be filled with a variety of materials which
15 can dictate the mechanical properties of the prostheses. The unfilled tubular balloon
16 graft can be folded and loaded into a catheter-based delivery system, and once in
17 position the tubular balloon graft can be "inflated" with the filler material. The
18 material would be filled in a fluid form and may stay a fluid form or can be solidified
19 by various means such as UV light, heat, and time. The advantage of this system is
20 that a metallic structure is not needed to provide structure to the graft. It is instead
21 replaced by the injectable fluid within the chamber of the tubular balloon graft.
22 Customization of the mechanical properties of the graft is easily accomplished by
23 using balloon fillers of varying properties.

24 [0007] The tubular balloon graft can be completely non-porous, completely porous
25 with same degree of porosity throughout the graft, completely porous with varying
26 porosity within the graft, or partially non-porous and partially porous. Significant
27 porosity on the very outer layer would allow for delivery of an aneurysm sac filling
28 substance or a drug. Porosity on the ends of the graft will help promote cellular in-
29 growth. Porosity on the ends can also be used to deliver an adhesive so that the graft
30 can be securely attached to the vessel wall.

31 [0008] Another embodiment of the tubular balloon graft includes a tubular balloon
32 graft with a bulging outer layer. This will allow the outer surface of the tubular
33 balloon graft to fill some or all of the aneurysm. This will provide a primary or

TJF 9004 - PCT

1 secondary barrier for the aneurysm wall from the pulsating blood flow and will
2 provide a means to prevent migration of the graft due to the enlarged area within the
3 graft. An alternate method of construction would be to attach a bulging outer skin to
4 a standard tubular thin-walled graft and provide a port for injection of the filler
5 substance. Alternatively, instead of a bulging outer skin, a very compliant outer skin
6 can be used so that the volume of material is minimized. The compliant outer skin
7 would be able to expand at very low inflation pressures that would be non-destructive
8 to the aneurysm wall.

9

10

BRIEF DESCRIPTION OF THE DRAWINGS

11

[0009] Figure 1A illustrates the two-part prosthesis.

12

[0010] Figure 1B illustrates a bifurcated version of the expandable tubular mesh
13 structure and the expandable sponge structure.

14

[0011] Figure 1C illustrates an expandable tubular mesh structure placed across an
15 aneurysm and the expandable sponge structure filling up the aneurysm.

16

[0012] Figures 2A-2C illustrate the various cross-sections of the expandable sponge
17 structure.

18

[0013] Figure 3A illustrates a long continuous sponge structure.

19

[0014] Figure 3B illustrates multiple short sponge structures.

20

[0015] Figure 4 illustrates the catheter-based delivery system.

21

[0016] Figure 5 illustrates a curved delivery catheter.

22

[0017] Figure 6 illustrates a method of ensuring that the delivery catheter's tip stays
23 inside the aneurysm sac.

24

[0018] Figure 7A illustrates an expandable basket-like structure.

25

[0019] Figure 7B illustrates an expandable braid-like structure.

26

[0020] Figures 8 and 9 illustrate expandable tubular mesh structures.

27

[0021] Figure 10 illustrates a delivery catheter tracked over a guidewire and placed in
28 a stent-graft which developed a leak.

29

[0022] Figure 11 illustrates the sponge delivered through the delivery catheter.

30

[0023] Figures 12-15 illustrate tubular balloon grafts.

31

[0024] Figures 16 and 17 illustrate tubular balloon grafts being expanded.

32

[0025] Figure 18 illustrates a tubular balloon graft.

TJF 9004 - PCT

1 [0026] Figures 19, 20A and 20 B illustrate a vascular graft with an integrated tubular
2 balloon.

3 [0027] Figures 21A-21E illustrate a method of delivering a graft with an external
4 balloon.

5

6

DETAILED DESCRIPTION

7

AND INDUSTRIAL APPLICABILITY

8 [0028] Figures 1A shows the two-part prosthesis comprising of an expandable sponge
9 structure 1 and an expandable tubular mesh structure 2 placed in an abdominal aortic
10 aneurysm 3 located in the infra-renal aorta not involving the iliac arteries. Figure 1B
11 shows a bifurcated version of the expandable tubular mesh structure 2 and the
12 expandable sponge structure 1 in an abdominal aortic aneurysm located in the infra-
13 renal aorta and involving both iliac arteries. Figure 1C shows an expandable tubular
14 mesh structure 2 placed across an aneurysm commonly found in cerebral arteries and
15 the expandable sponge structure 1 filling up the aneurysm. The expandable sponge
16 structure 1 is placed through the expandable tubular mesh structure 2 into the
17 aneurysm, filling up the aneurysmal sac which provides a barrier between the thin
18 fragile wall of the aneurysm and the pressurized pulsating blood. The tubular mesh
19 structure 2 keeps the expanded sponge 1 within the confines of the aneurysm and
20 away from the flow path.

21 [0029] The expandable sponge structure 1 is preferably made of common medical
22 grade polymers or natural substances like collagen which can be manufactured into a
23 sponge structure. The sponge structure can be processed in such a way so that it can
24 be compressed to a dry condition size substantially smaller than the wet condition
25 size, exhibiting huge expansion ratio. The expanded sponge structure can take
26 various forms. Figures 2A-2C show the various expanded cross-sections that the
27 expandable sponge structure 1 can be. Figure 2A shows a circular cross section,
28 Figure 2B shows a square cross section, and Figure 2C show a triangular cross
29 section. Any cross section can be used. The most important requirement is that it
30 cannot escape from the aneurysm sac through a cell of the expandable tubular mesh
31 structure 2. The length of the expandable sponge structure 1 can vary as well. Figure
32 3A shows a long continuous structure 1. And Figure 3B shows multiple short
33 structures 1.

TJF 9004 - PCT

1 [0030] One method of delivering the sponge filler 1 into the aneurysm sac is shown
2 by the catheter-based delivery system in Figure 4. The catheter 4 can hold the
3 compressed sponge 1 within its lumen, and when pushed out with the plunger 5 into
4 the blood filled aneurysm sac, the sponge will expand out to a substantially larger
5 size. The expanded size of the sponge filler is preferably larger than the largest
6 opening of the tubular mesh structure as to prevent the sponge from escaping the
7 aneurysm sac. Figure 5 shows an example of a curved delivery catheter 4, where the
8 tip is placed through a cell of the tubular mesh structure 2 and the expandable sponge
9 structure 1 is being deployed into the aneurysm sac. It is important that the tip of the
10 delivery catheter is through a cell of the tubular mesh structure into the aneurysm
11 because the expandable sponge will expand very quickly after being exposed to the
12 blood and being unconstrained by a catheter. Figure 6 shows a method of ensuring
13 that the delivery catheter's 4 tip stays inside the aneurysm sac by having a balloon 6
14 on the tip of it, and when inflated after the tip is within the aneurysm sac it will
15 prevent the catheter tip from backing out of the aneurysm sac. Figure 7A shows an
16 expandable basket-like structure 7 and Figure 7B shows an expandable braid-like
17 structure 8 which are alternatives to having a balloon 6 on the tip of the catheter 4.

18 [0031] The expandable tubular mesh structure 2 can be made of a metal or of a
19 polymer. The versions made of a metal can be self-expanding from a smaller
20 compressed state or balloon expandable from a smaller compressed or as-cut state.
21 The self-expanding version may be made of metals which exhibit large amounts of
22 elasticity (i.e. nickel-titanium, spring steel, MP-35N and elgiloy) such that when they
23 are compressed down from their expanded state to the compressed state to load into a
24 delivery catheter, they will substantially return to their expanded condition when
25 released from the catheter. Alternatively, shape memory metals like nickel-titanium
26 can be used to provide large expansion ratios. The balloon expandable version may
27 be made of metals which exhibit large permanent deformations without significantly
28 compromising the mechanical performance. The following are some common
29 medical grade metals which are well suited for this purpose: stainless steel, titanium,
30 tantalum, and martensitic nickel titanium. In either the self-expanding or the balloon
31 expandable case, the intent is to deliver the expandable tubular mesh 2 to the target
32 site in a smaller or compressed condition via a catheter-based delivery system so that

TJF 9004 - PCT

1 the target site can be accessed through a remote vascular access point which is
2 conducive to a percutaneous or minimally invasive approach.

3 **[0032]** The expandable tubular mesh structure 2 shown in Figures 1A, 1B, 1C, 5, and
4 6 represent a generic mesh structure. Figure 8 shows an expandable tubular mesh
5 structure where long continuous struts 9 are connected to anchoring end members 10.
6 This allows the structure to be very low in profile in the compressed state, and the
7 durability of this type of structure can be optimized because no radial element exists
8 in the longitudinal struts 9. Figure 9 show an alternate expandable tubular mesh
9 structure preferably made from a polymer such as PTFE, Polyester, Polyurethane, and
10 the like. The structure has relatively large holes 11 to give access to the expandable
11 sponge delivery catheter. The ends incorporate an anchoring member 12, either self-
12 expanding or balloon expandable.

13 **[0033]** Figure 10 shows a delivery catheter 4 which has been tracked over a guidewire
14 14, which has been placed into the aneurysm sac through an opening 15 of an existing
15 endoluminal stent-graft 13 which developed a leak. The balloon 6 on the delivery
16 catheter 4 was inflated after the delivery catheter 4 was positioned within the
17 aneurysm sac. Figure 11 shows the guidewire 14 removed, and the expandable
18 sponge structure 1 being delivered through the delivery catheter 4.

19 **[0034]** Figure 12 shows a section view of a tubular balloon graft 19 positioned across
20 an infra-renal aortic aneurysm blocking off the flow to the aneurysm sac. The tubular
21 balloon graft's 19 wall is made of an inner wall 16, an outer wall 17 and a chamber 18
22 between them. The chamber 18 can be filled with various materials to dictate the
23 mechanical properties of the prosthesis. Figure 13 shows a bifurcated tubular balloon
24 graft 20 positioned across an infra-renal aortic aneurysm with bi-lateral iliac
25 involvement.

26 **[0035]** The tubular balloon implant can be made of the various biocompatible
27 materials used to make balloon catheters. Those materials include P.E.T. (Polyester),
28 nylon, urethane, and silicone. It can also be made of other implant grade materials
29 such as ePTFE. One method of making such a device is to start with two thin walled
30 tubes of differing diameters. The difference between the diameters of the tubes will
31 dictate the volume of the balloon chamber. The ends of the tubes can be sealed
32 together with adhesive or by heat to form the balloon chamber. A communication
33 port will be necessary to be able to fill the port with the injected material.

TJF 9004 - PCT

1 **[0036]** The injected material can be an epoxy, a UV-curable epoxy, silicone, urethane
2 or other type of biocompatible materials such as albumin, collagen, and gelatin glue
3 which is injected into the balloon, and then cured in situ. Or, the injected material
4 doesn't necessarily have to be cured. The as-delivered state may provide the
5 appropriate mechanical properties for the application. Therefore, substances like
6 sterile saline, biocompatible oils, or biocompatible adhesives can be left in the tubular
7 balloon in the as-delivered state.

8 **[0037]** The tubular balloon graft can be non-porous to very porous. Figure 14 shows
9 a version where the tubular balloon graft has a porous outer wall 24. The chamber 21
10 of the tubular balloon graft can be used to deliver an aneurysm sac filling substance
11 such as UV curable adhesive 22. The holes 23 which dictate the porosity of the
12 tubular balloon graft can be created with laser drilling, etching, and other methods.
13 The porosity can be varied in select areas of the graft. Figure 15 shows a tubular
14 balloon graft with only the ends of the graft have porosity to either promote cellular
15 in-growth or to inject an adhesive which allows secure attachment of the graft ends to
16 the vessel wall.

17 **[0038]** Figure 16 shows a tubular balloon graft 19 which is being expanded from a
18 folded condition (not shown) by a balloon catheter 25. Once expanded, the chamber
19 18 of the tubular balloon graft 19 can be filled with the desired substance through the
20 chamber access port 26. Figure 17 shows a tubular balloon graft 19 being expanded
21 by an inflation process or filling the chamber 18 of the tubular balloon graft 19
22 through the chamber access port 26.

23 **[0039]** Figure 18 shows a version of the tubular balloon graft with an outer wall 17
24 which is substantially bulged out so that it fills some or all of the aneurysm sac.
25 Figure 19 shows a vascular graft 27 which has an integrated balloon 28 attached to the
26 outside surface of the graft. The balloon can be pre-bulged and folded down for
27 delivery, or it can be a very compliant material like silicone, urethane, or latex so that
28 it has no folds whether compressed or expanded. Figure 20A shows the same type of
29 implant, a graft 27 with an external balloon 28, used in a cerebral vessel aneurysm 29.
30 Figure 20B show the same implant as 20A, except that the implant balloon does not
31 fully fill the aneurysm, which can be acceptable because the graft 27 excludes the
32 aneurysm from the blood flow, and the primary purpose of the balloon 28 is to
33 prevent migration of the graft 27.

TJF 9004 - PCT

1 [0040] The graft 27 can be made of commonly used implant polymers such as PTFE,
2 Polyester, Polyurethane, etc. The balloon 28 surrounding the graft can be made of the
3 same commonly used vascular implant materials as well. The graft and balloon
4 materials can be different, but it is commonly known that using the same material for
5 both would facilitate processing/manufacturing. The theory is that the balloon 28
6 would preferentially only deploy into the aneurysm sac where the resistance to
7 expansion is minimal as compared to the vessel wall. The graft 27 would provide the
8 primary barrier between the pressurized blood and the thin wall of the aneurysm.
9 Secondly, the balloon itself provides a buffer from the pressurized blood. The
10 balloon's 28 primary function, however, is to hold the graft 27 in place. Since the
11 expanded section of the implant is "locked" into the aneurysm, the graft 27 should not
12 migrate. Also, the balloon 28, in the filled state, will provide hoop strength to the
13 graft 27.

14 [0041] Figures 21A-21E demonstrate one method of delivering a graft with an
15 external balloon to the target site. Figure 21A shows the implant loaded onto a
16 balloon delivery catheter 30 with an outer sheath 32 and positioned over a guide wire
17 31 at the aneurysm target site. Figure 21B shows that once in position, the outer
18 sheath 32 is withdrawn. Figure 21C shows the balloon delivery catheter 33 being
19 inflated, pushing the implant 34 against the healthy vessel walls on both sides of the
20 aneurysm. Figure 21D shows that the balloon delivery catheter 30 may also have an
21 implant balloon inflation port 35 which can now be used to fill up the implant balloon
22 28 with a biocompatible substance. The substance can be sterile saline, contrast
23 agent, hydrogel, and UV cure adhesive to name a few. Most likely, low inflation
24 pressures would be used to fill the implant balloon 28. Figure 21E shows that once
25 the implant balloon 28 is filled, the implant balloon inflation port 35 can be detached
26 and the delivery catheter 30 removed.

27

TJF 9004 - PCT

1
2
3
4
5
6
7
8
9
10
11
12
13
14
15
16
17
18
19
20
21
22
23
24
25
26
27
28
29
30
31
32
33

CLAIMS

We claim:

1. An assembly for filling an aneurysm sac comprising:
 - an expandable mesh comprising cells, and
 - an expandable space-occupying device having a cross-section, wherein the device is placed in the aneurysm sac and the mesh prevents the device from escaping from the aneurysm sac.
2. The assembly of Claim 1, wherein the device has an expanded size larger than the largest cell.
3. The assembly of Claim 1, wherein the mesh comprises an anchoring member.
4. The assembly of Claim 1, wherein the device comprises polymer.
5. The assembly of Claim 1, wherein the device comprises collagen.
6. The assembly of Claim 1, wherein the cross-section of the device is circular.
7. The assembly of Claim 1, wherein the cross-section of the device is square.
8. The assembly of Claim 1, wherein the cross-section of the device is triangular.
9. The assembly of Claim 1, wherein the mesh comprises long continuous struts.
10. The assembly of Claim 1, wherein the device comprises a sponge.
11. The assembly of Claim 10, wherein the device has an expanded size larger than the largest cell.
12. The assembly of Claim 10, wherein the mesh comprises an anchoring member.
13. The assembly of Claim 10, wherein the device comprises polymer.
14. The assembly of Claim 10, wherein the device comprises collagen.
15. The assembly of Claim 10, wherein the cross-section of the device is circular.
16. The assembly of Claim 10, wherein the cross-section of the device is square.
17. The assembly of Claim 10, wherein the cross-section of the device is triangular.
18. The assembly of Claim 10, wherein the mesh comprises long continuous struts.
19. A device for filling an aneurysm cavity comprising:
 - A graft comprising an inner wall and an outer wall, wherein the inner wall and the outer wall form a chamber, and wherein the chamber is filled with a filler material, and wherein the graft is detached from a delivery catheter.
20. The device of Claim 19, wherein the filler material comprises an epoxy.
21. The device of Claim 19, wherein the filler material comprises silicone.
22. The device of Claim 19, wherein the filler material comprises urethane.

TJF 9004 - PCT

- 1 23. The device of Claim 19, wherein the filler material comprises albumin.
- 2 24. The device of Claim 19, wherein the filler material comprises collagen.
- 3 25. The device of Claim 19, wherein the filler material comprises gelatin glue.
- 4 26. The device of Claim 19, wherein the filler material comprises saline.
- 5 27. The device of Claim 19, wherein the filler material comprises a contrast agent.
- 6 28. The device of Claim 19, wherein the filler material comprises a biocompatible
7 oil.
- 8 29. The device of Claim 19, wherein the filler material comprises a biocompatible
9 adhesive.
- 10 30. The device of Claim 19, wherein the filler material is cured by UV light.
- 11 31. The device of Claim 19, wherein the outer wall is porous.
- 12 32. The device of Claim 19, wherein the graft is non-porous.
- 13 33. A method for filling an aneurysm sac comprising,
14 placing an expandable structure across an aneurysm,
15 filling the aneurysm sac with a space-occupying device.
- 16 34. The method of Claim 33, wherein filling comprises placing a delivery catheter
17 into the aneurysm sac.
- 18 35. The method of Claim 34, wherein filling further comprises inflating a balloon on
19 the delivery catheter after the delivery catheter is placed into the aneurysm cavity.
- 20 36. The method of Claim 35, wherein filling further comprises delivering the device
21 through the delivery catheter.
- 22 37. The method of Claim 36, wherein delivering the device comprises pushing the
23 device out of the catheter with a plunger.
- 24 38. The method of Claim 33, wherein the space-occupying device comprises a
25 sponge.
- 26 39. The method of Claim 38, wherein filling comprises placing a delivery catheter
27 into the aneurysm sac.
- 28 40. The method of Claim 39, wherein filling further comprises inflating a balloon on
29 the delivery catheter after the delivery catheter is placed into the aneurysm cavity.
- 30 41. The method of Claim 40, wherein filling further comprises delivering the device
31 through the delivery catheter.
- 32 42. The method of Claim 41, wherein delivering the device comprises pushing the
33 device out of the catheter with a plunger.

TJF 9004 - PCT

- 1 43. A method for filling an aneurysm cavity with a graft comprising an implant
2 balloon, the method comprising,
3 positioning the graft at the aneurysm, wherein the graft is loaded on a delivery
4 catheter,
5 inflating the implant balloon, and
6 detaching and removing the catheter from the graft.
- 7 44. The method of Claim 43, wherein inflating the balloon comprises inflating with
8 an epoxy.
- 9 45. The method of Claim 43, wherein inflating the balloon comprises inflating with
10 silicone.
- 11 46. The method of Claim 43, wherein inflating the balloon comprises inflating with
12 urethane.
- 13 47. The method of Claim 43, wherein inflating the balloon comprises inflating with
14 albumin.
- 15 48. The method of Claim 43, wherein inflating the balloon comprises inflating with
16 collagen.
- 17 49. The method of Claim 43, wherein inflating the balloon comprises inflating with
18 gelatin glue.
- 19 50. The method of Claim 43, wherein inflating the balloon comprises inflating with
20 saline.
- 21 51. The method of Claim 43, wherein inflating the balloon comprises inflating with a
22 contrast agent.
- 23 52. The method of Claim 43, wherein inflating the balloon comprises inflating with a
24 biocompatible oil.
- 25 53. The method of Claim 43, wherein inflating the balloon comprises inflating with a
26 biocompatible adhesive.
- 27 54. The method of Claim 43, wherein inflating the balloon comprises inflating with a
28 UV cure adhesive.
29

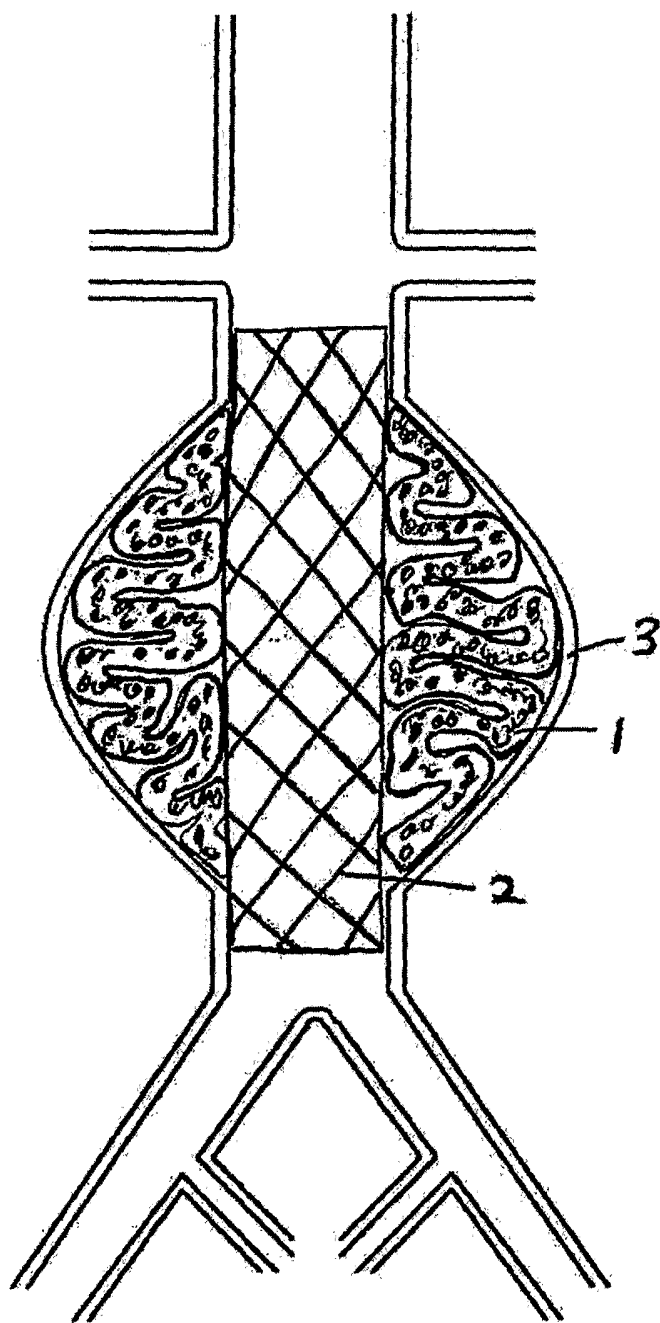

FIGURE 1A

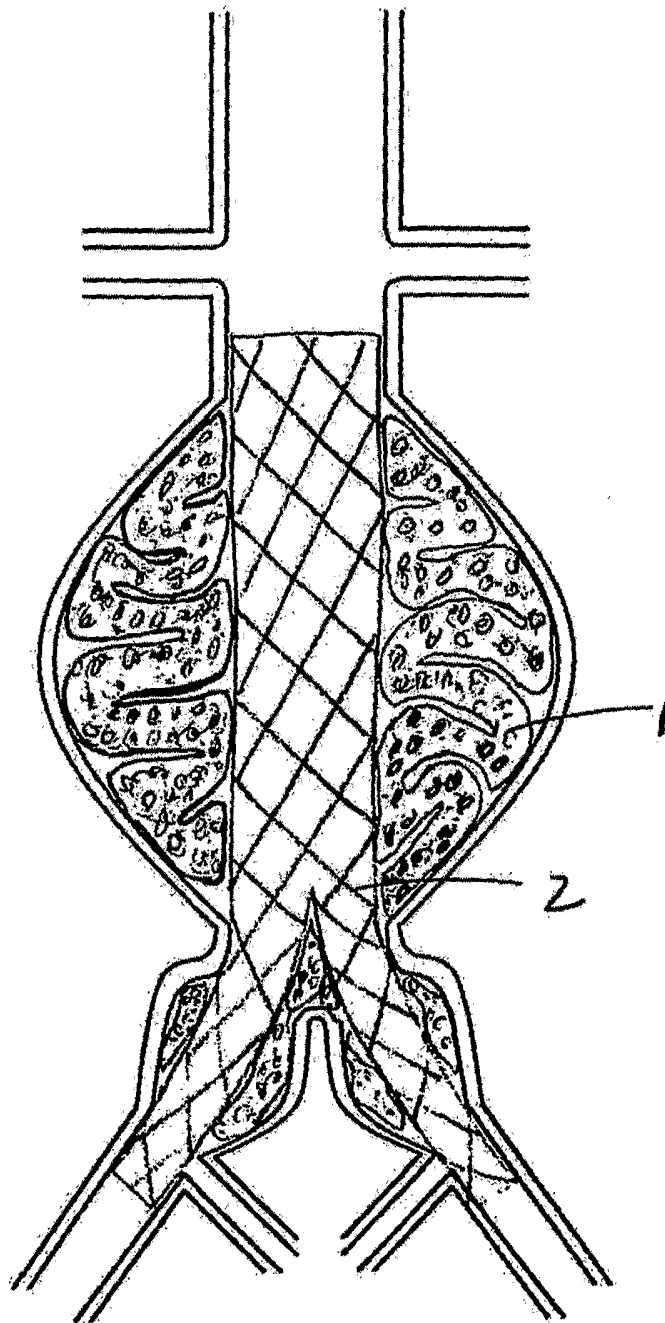

FIGURE 1B

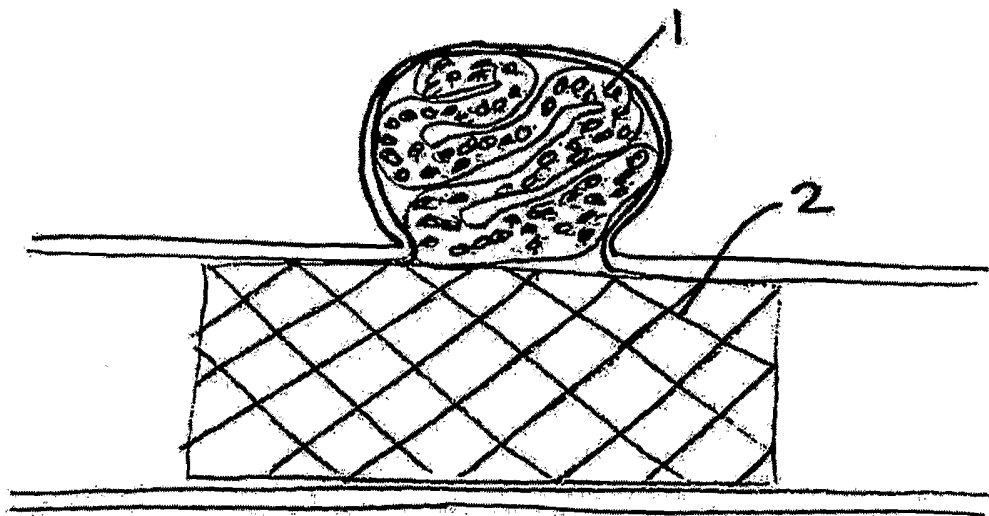

FIGURE 1C



FIGURE 2A

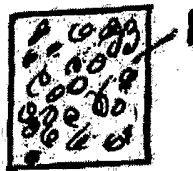

FIGURE 2B



FIGURE 2C



FIGURE 3A

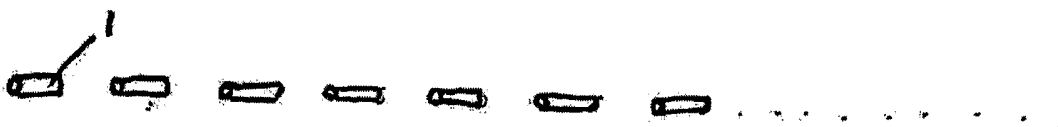

FIGURE 3B

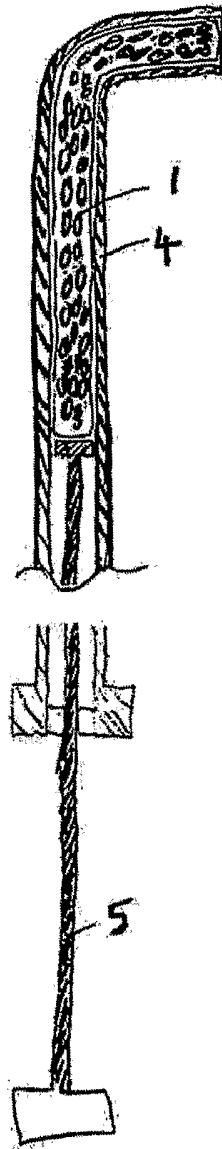

FIGURE 4

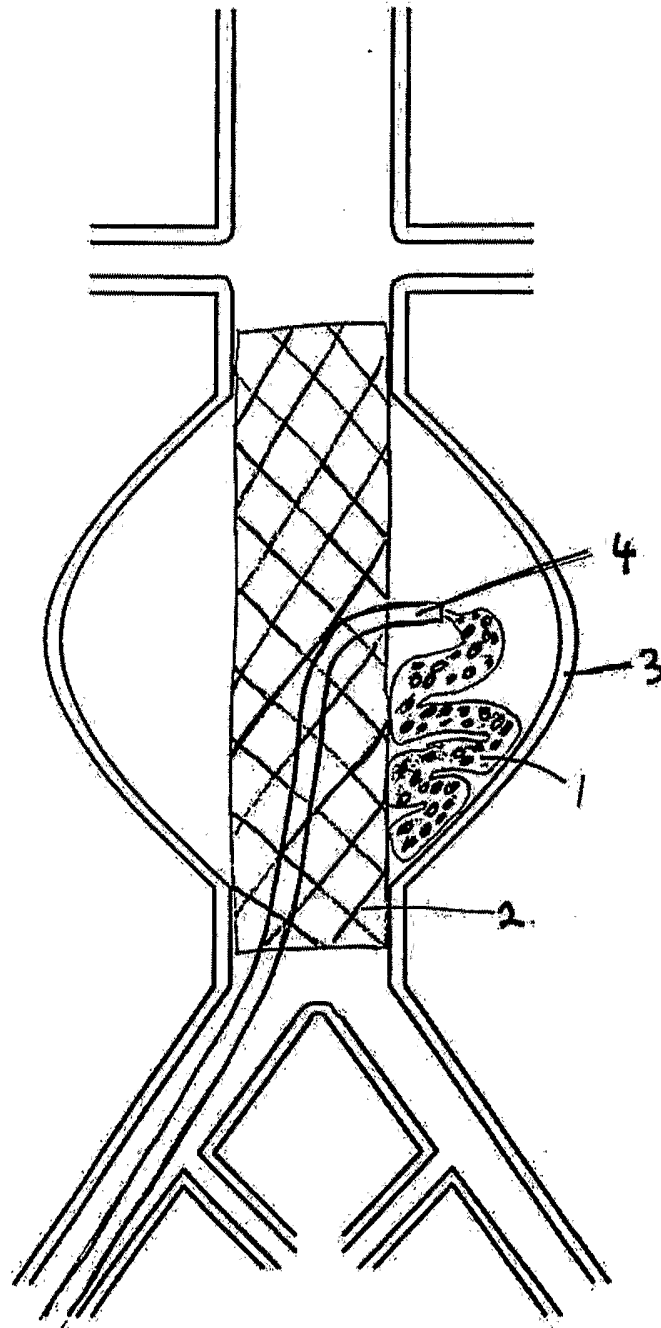

Figure 5

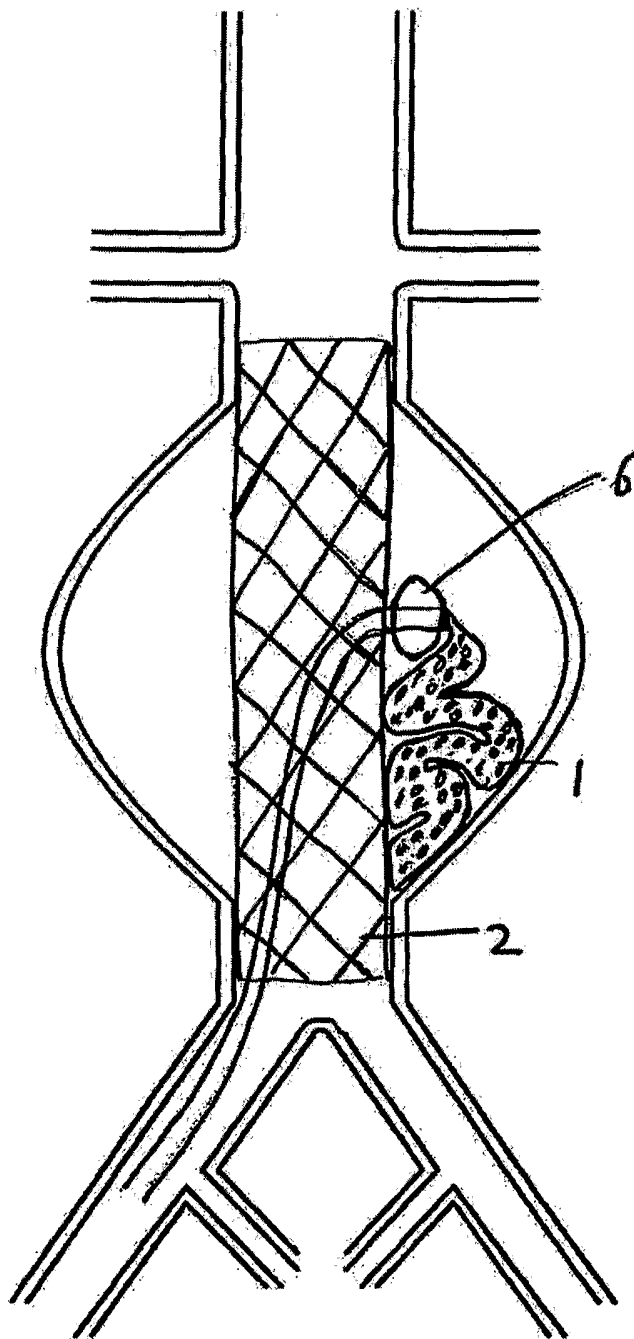

FIGURE 6

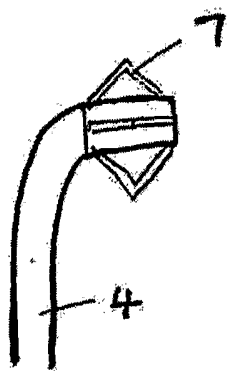

FIGURE 7A

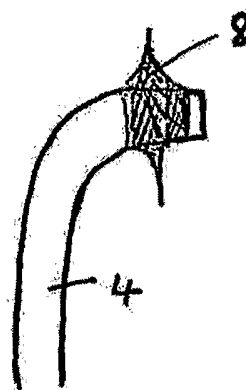

FIGURE 7B

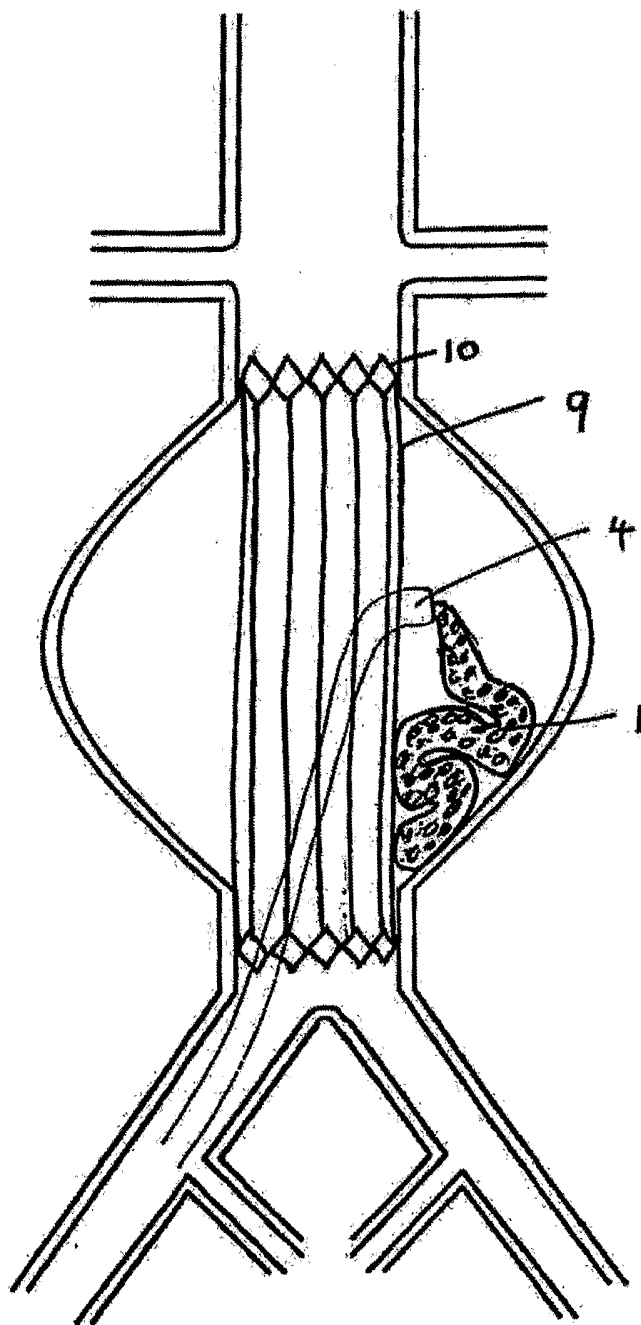

FIGURE 8

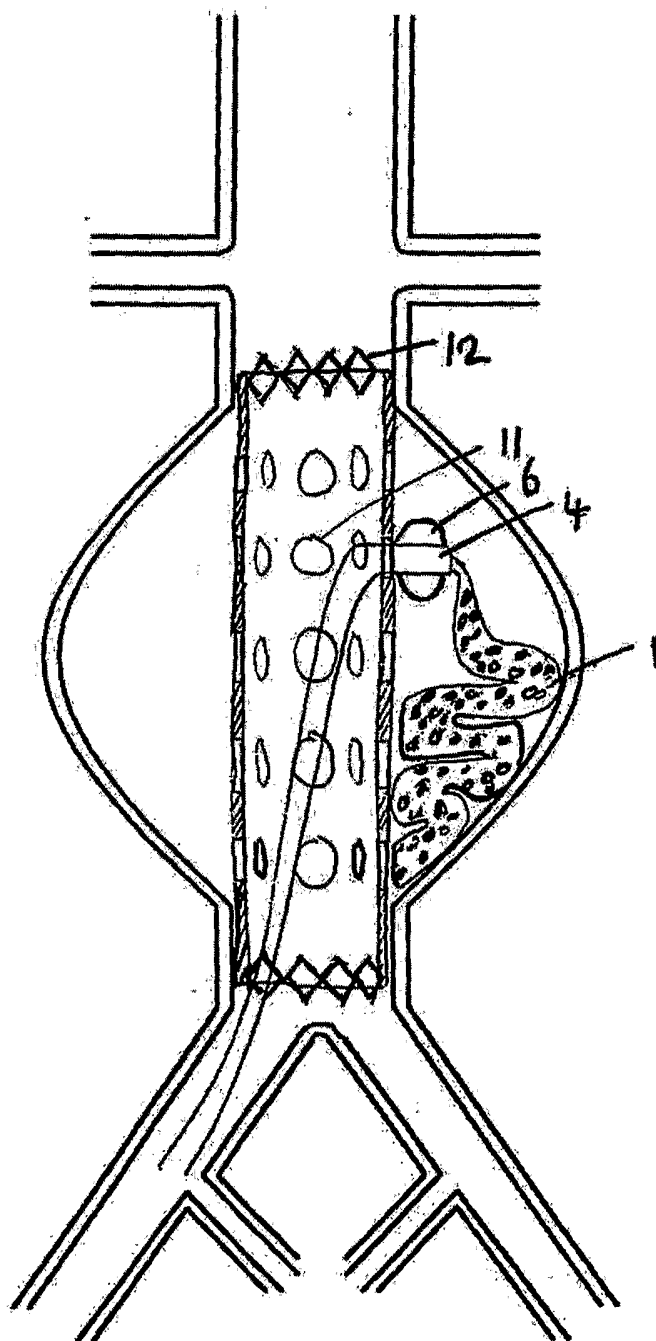

FIGURE 9

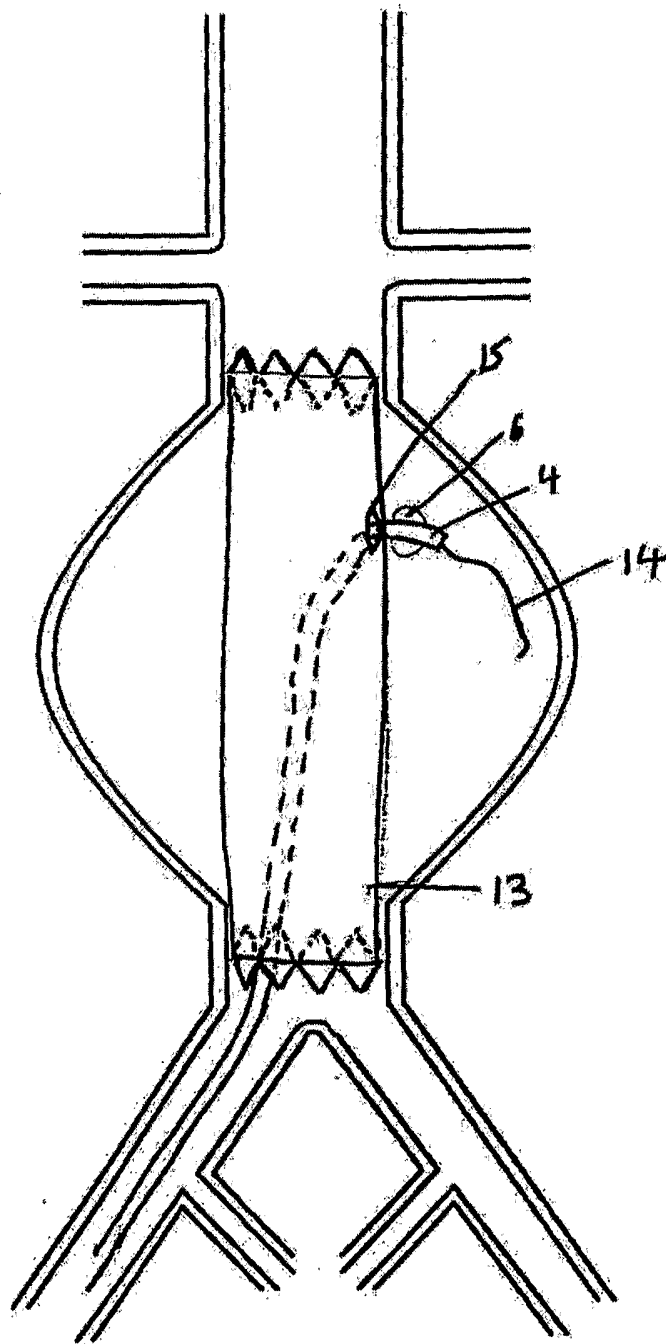

FIGURE 10

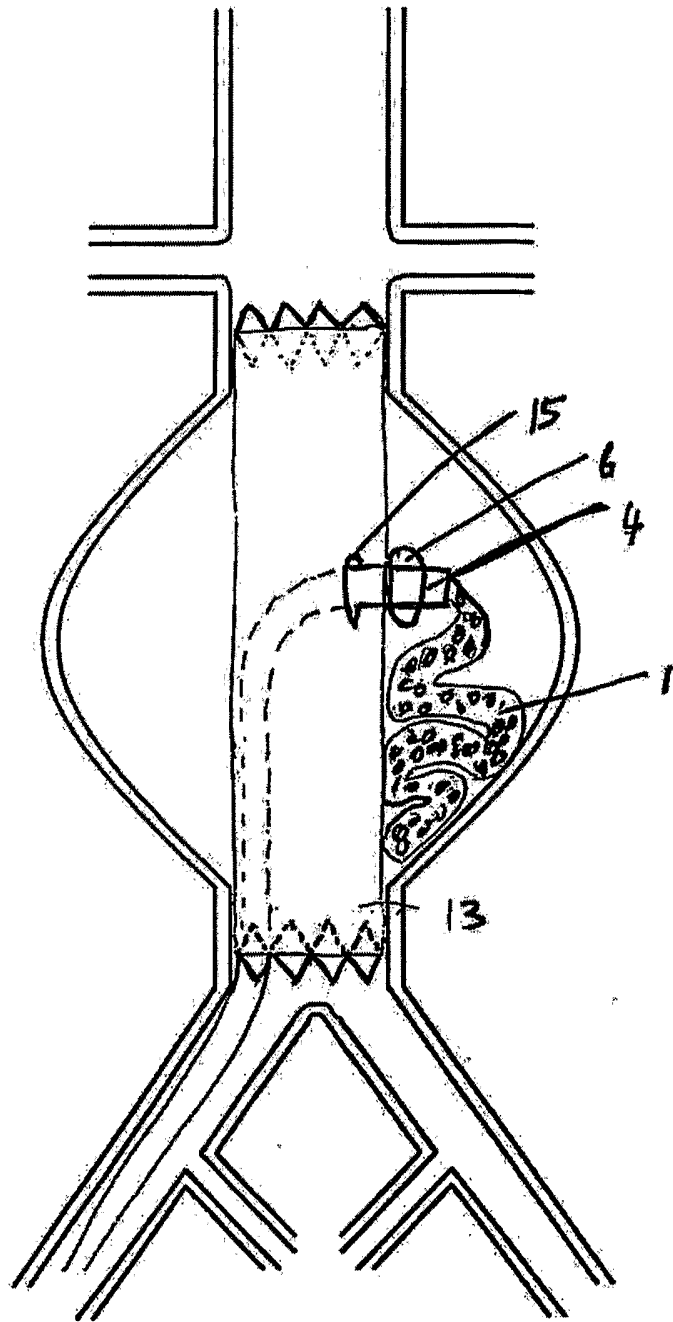

FIGURE 11

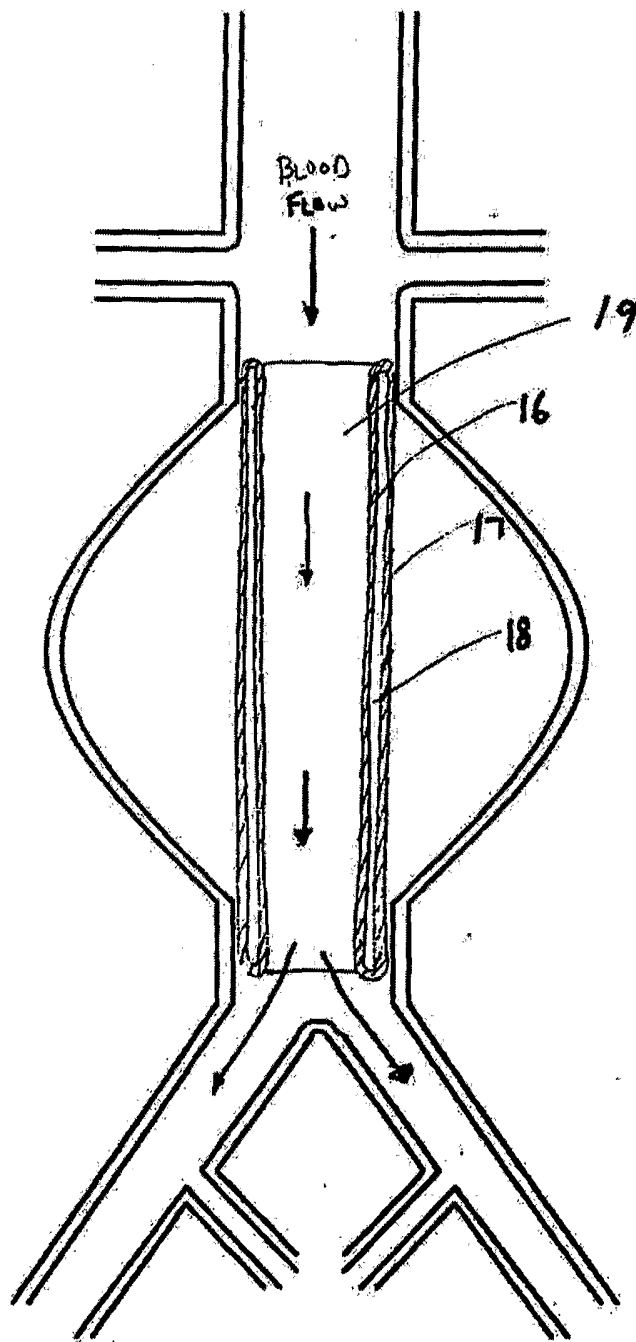

FIGURE 12

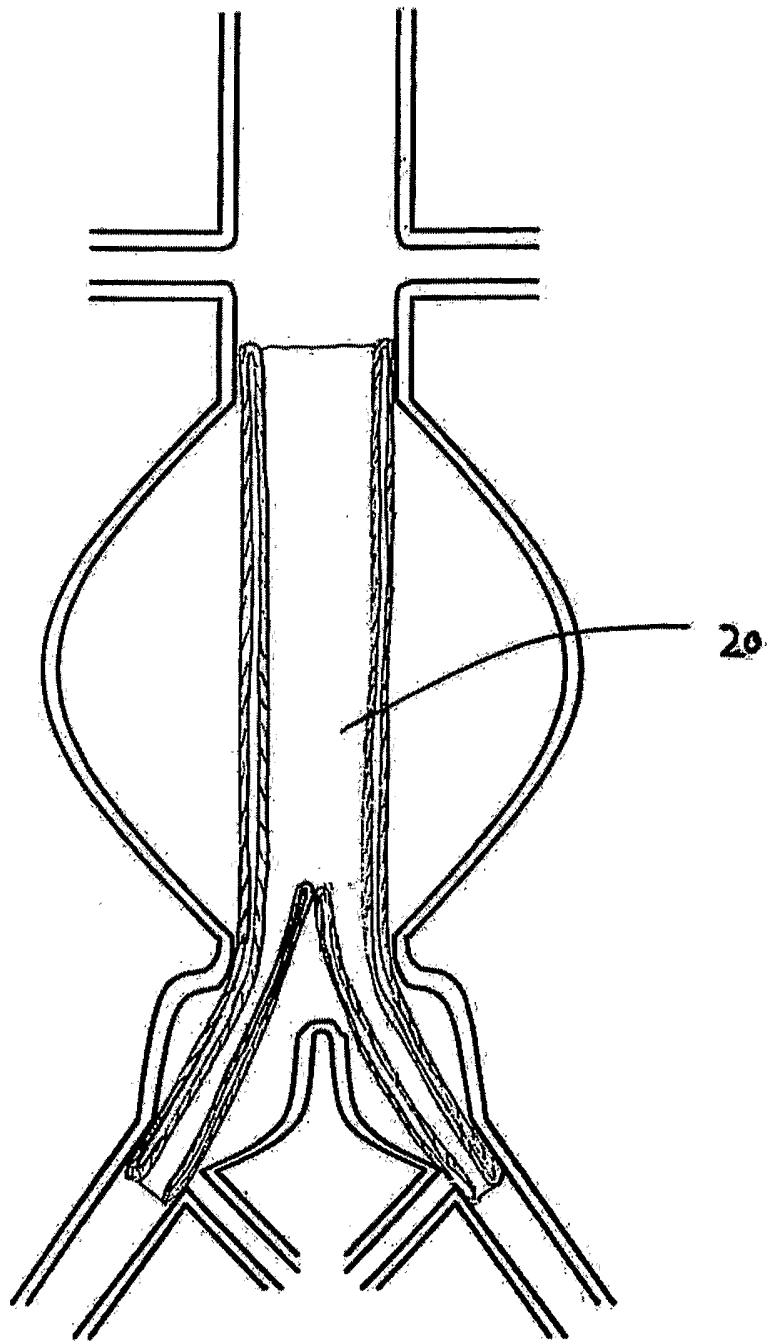

FIGURE 13

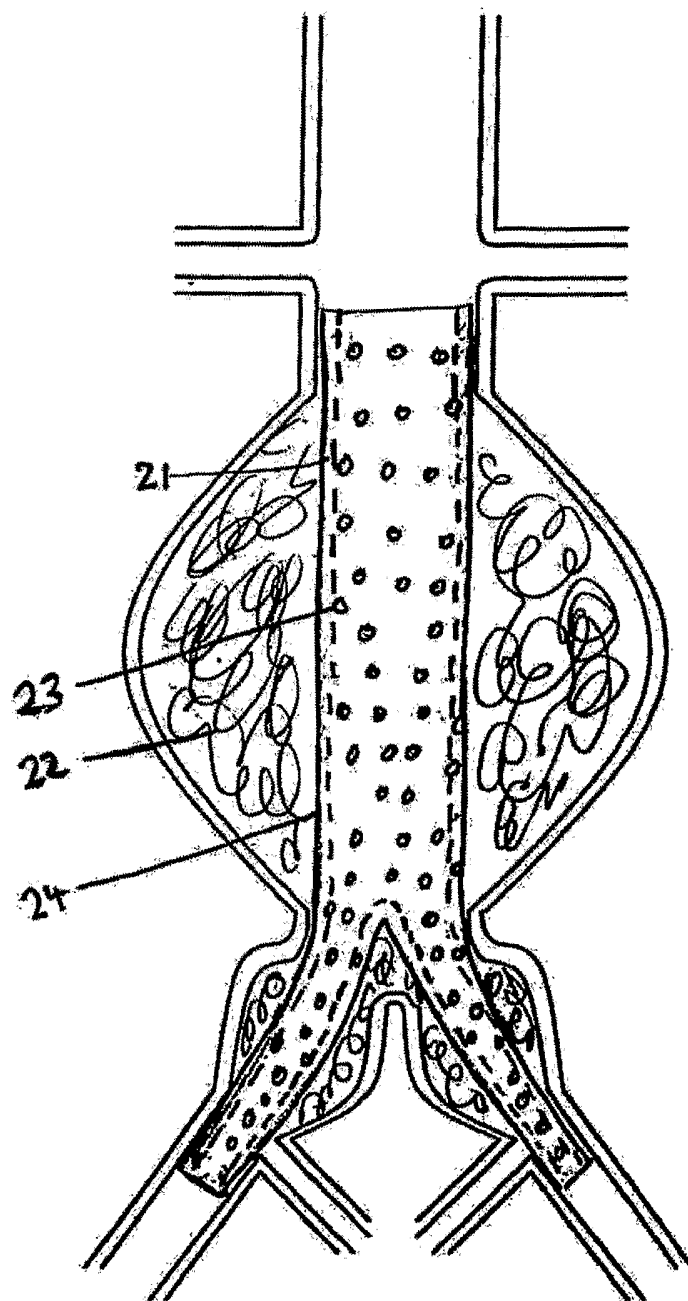

FIGURE 14

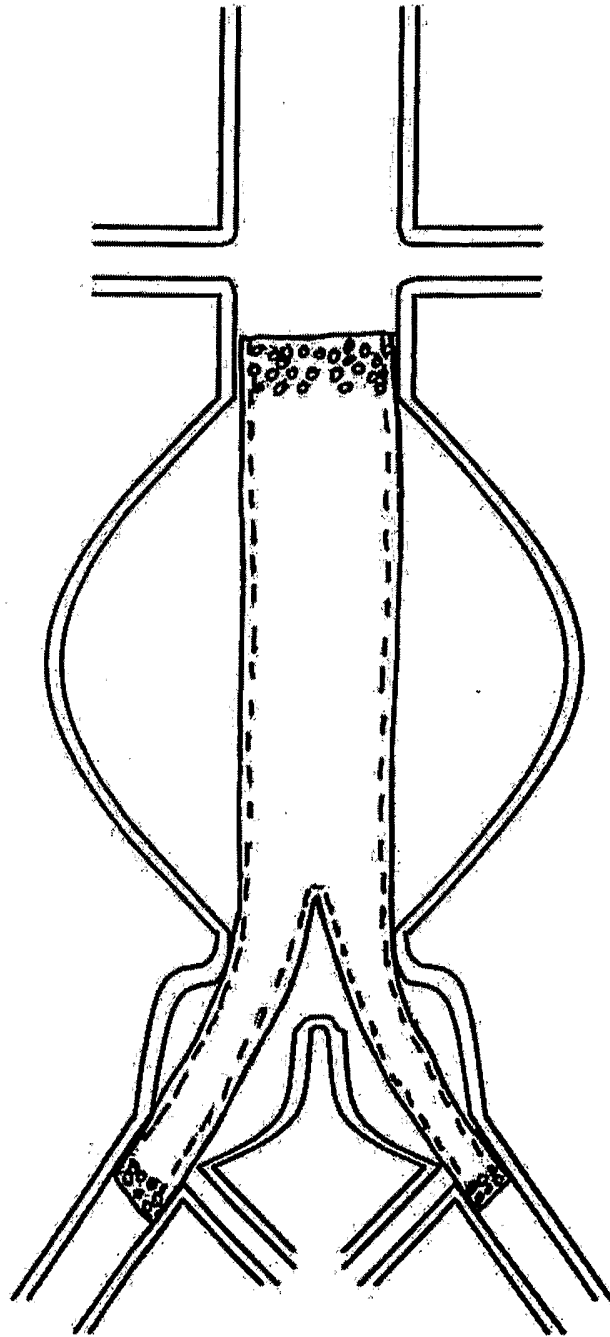

FIGURE 15

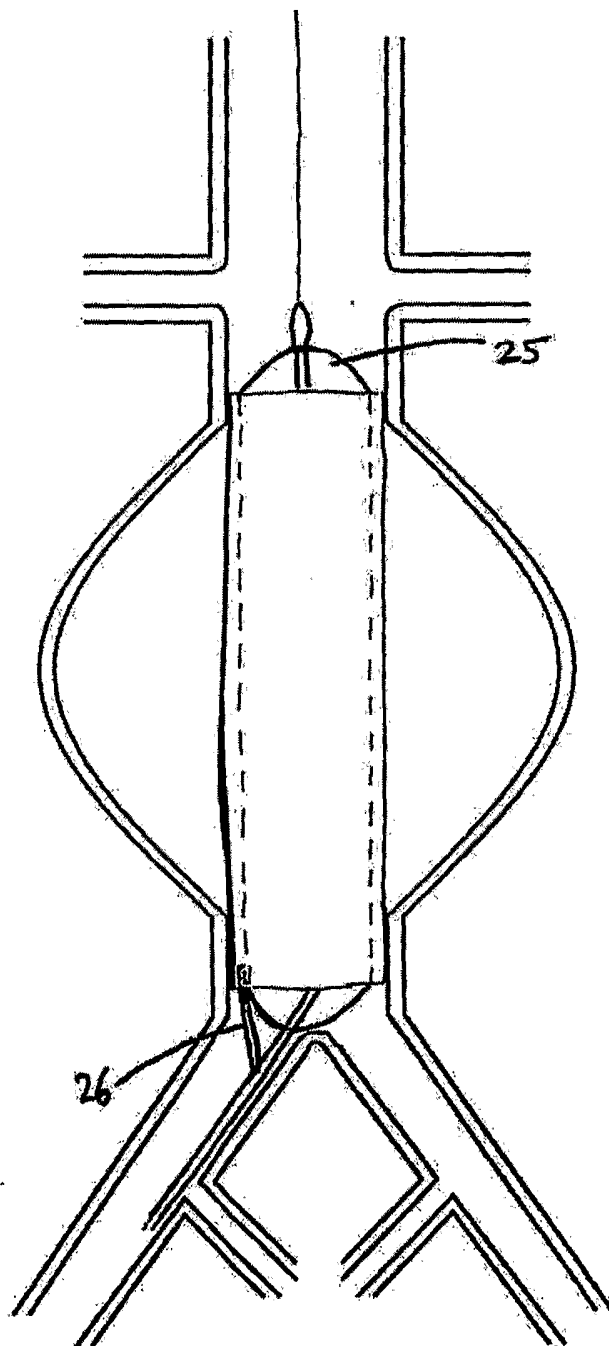

FIGURE 16

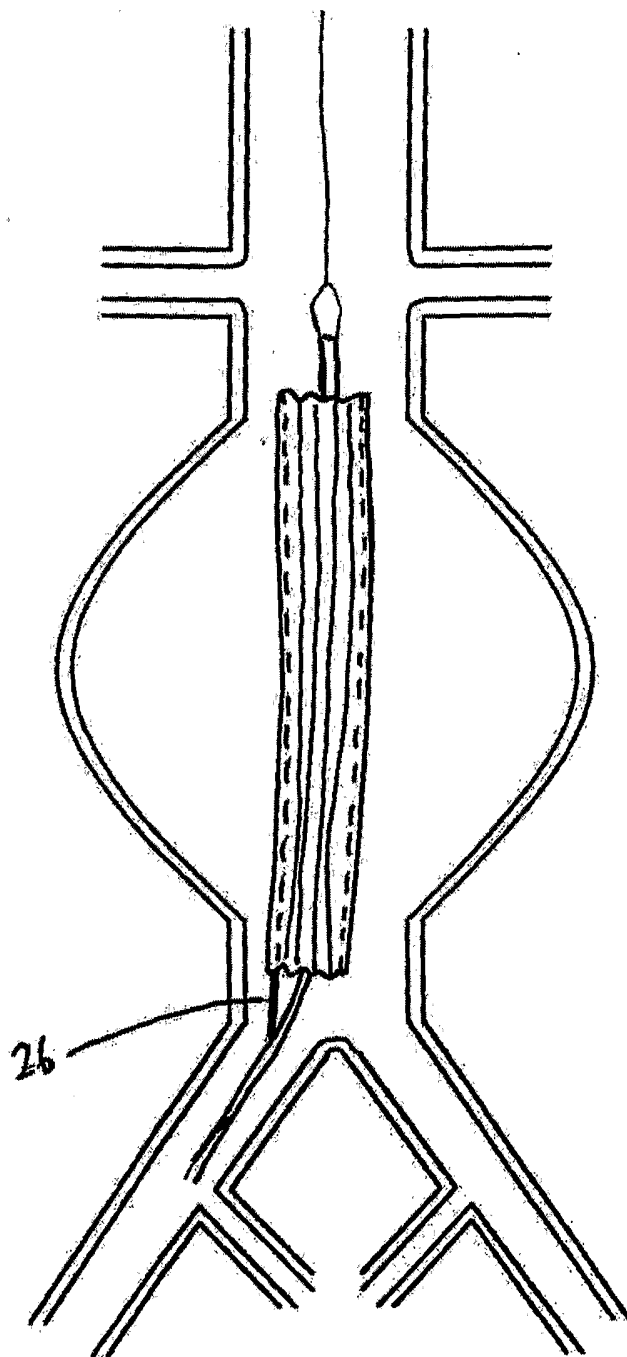

FIGURE 17

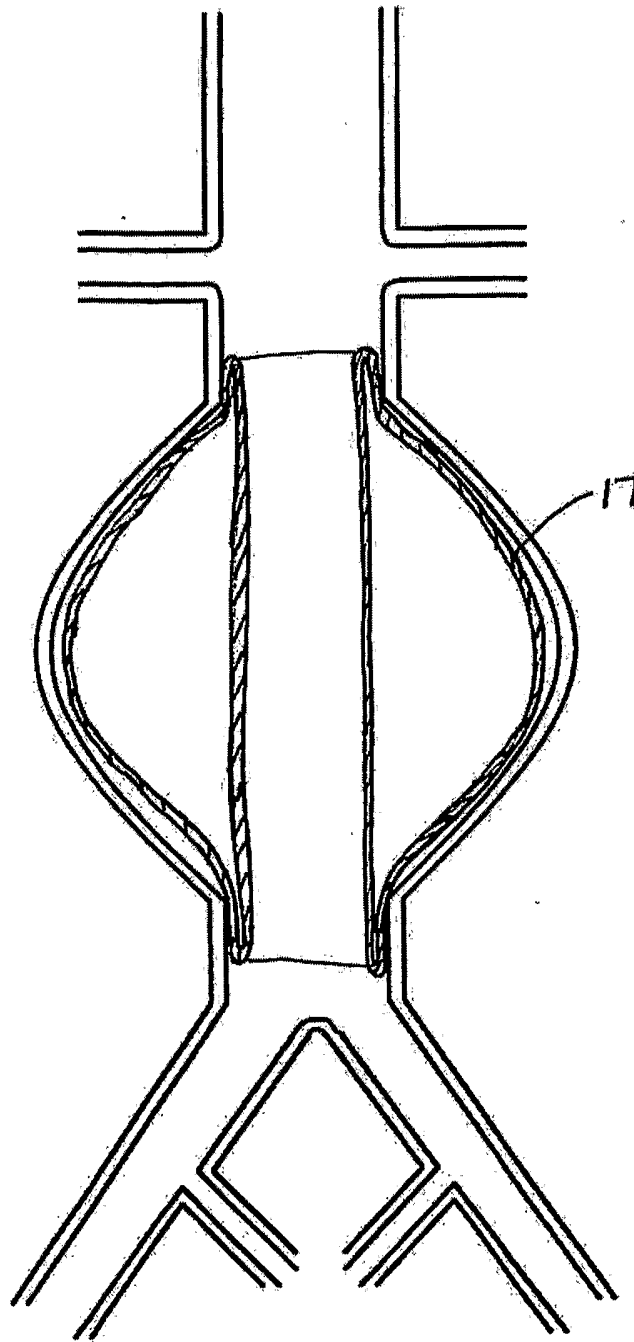

FIGURE 18

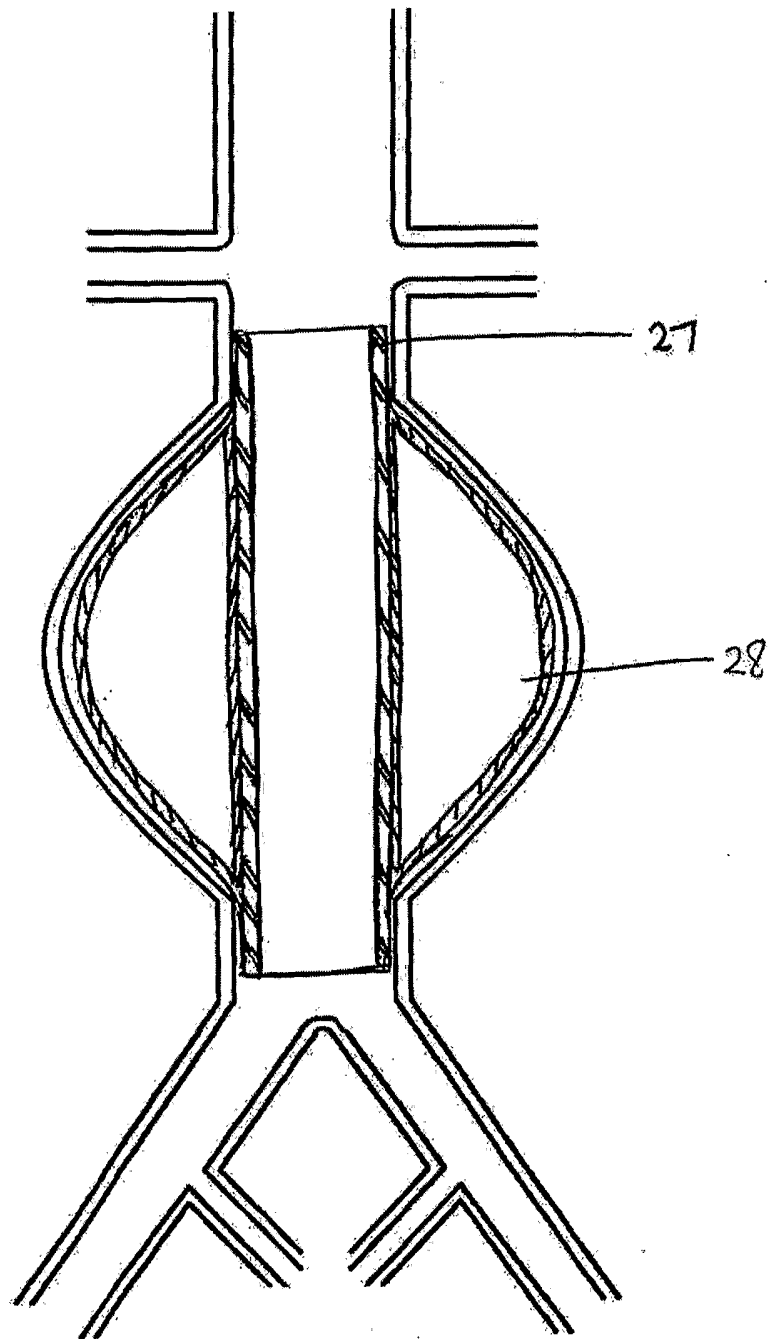

FIGURE 19

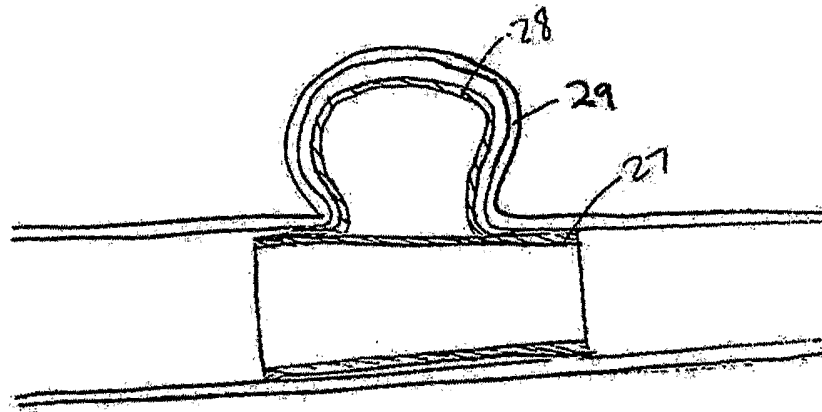

FIGURE 20 A

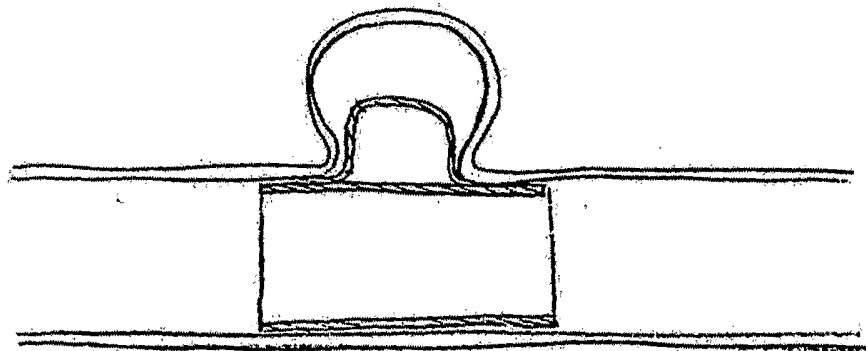

FIGURE 20 B

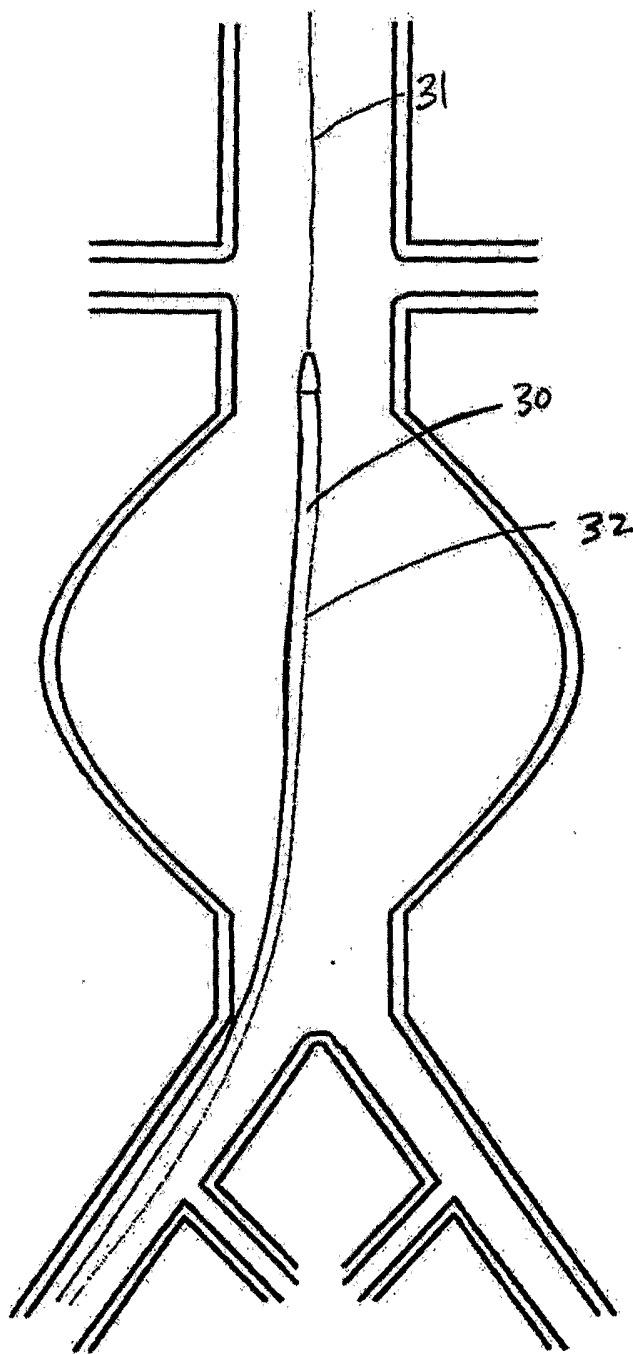

FIGURE 21 A

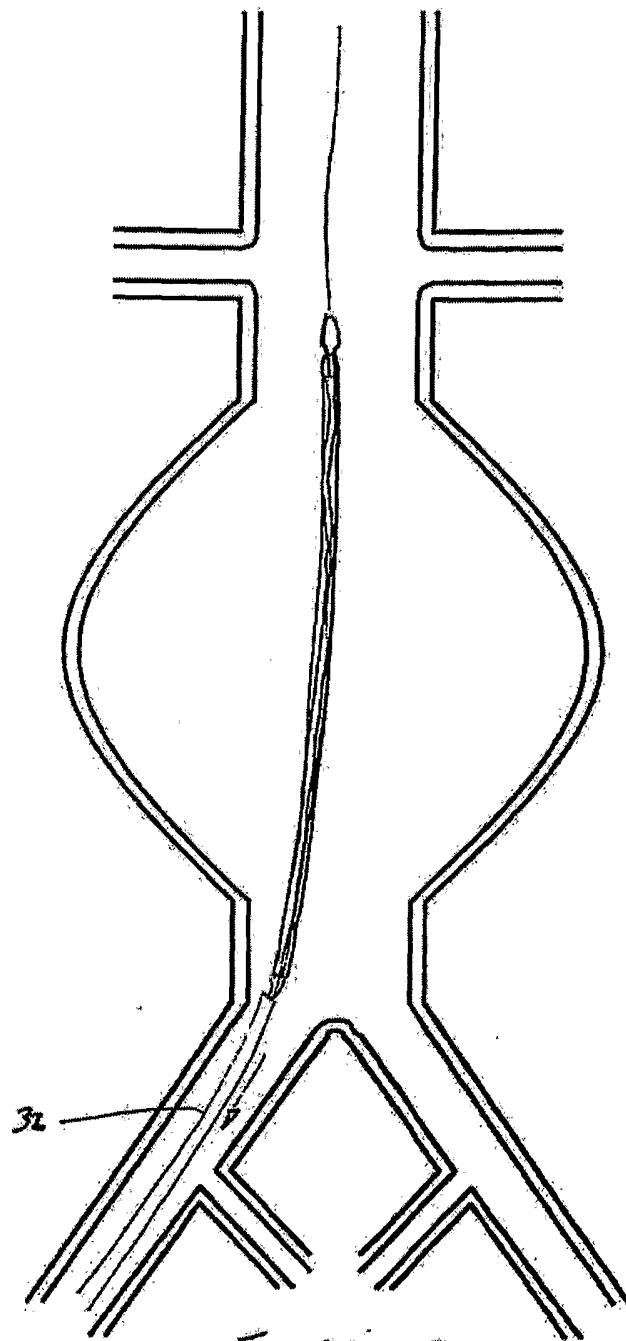

FIGURE 21B

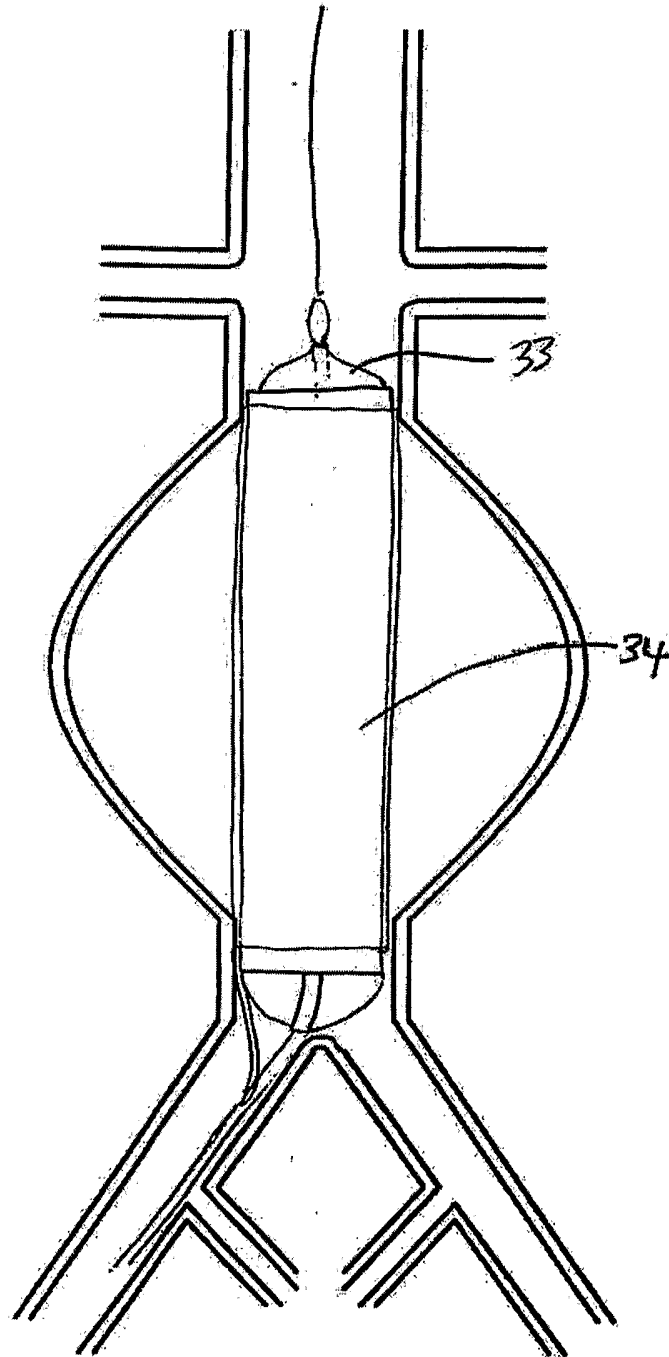

FIGURE 21c

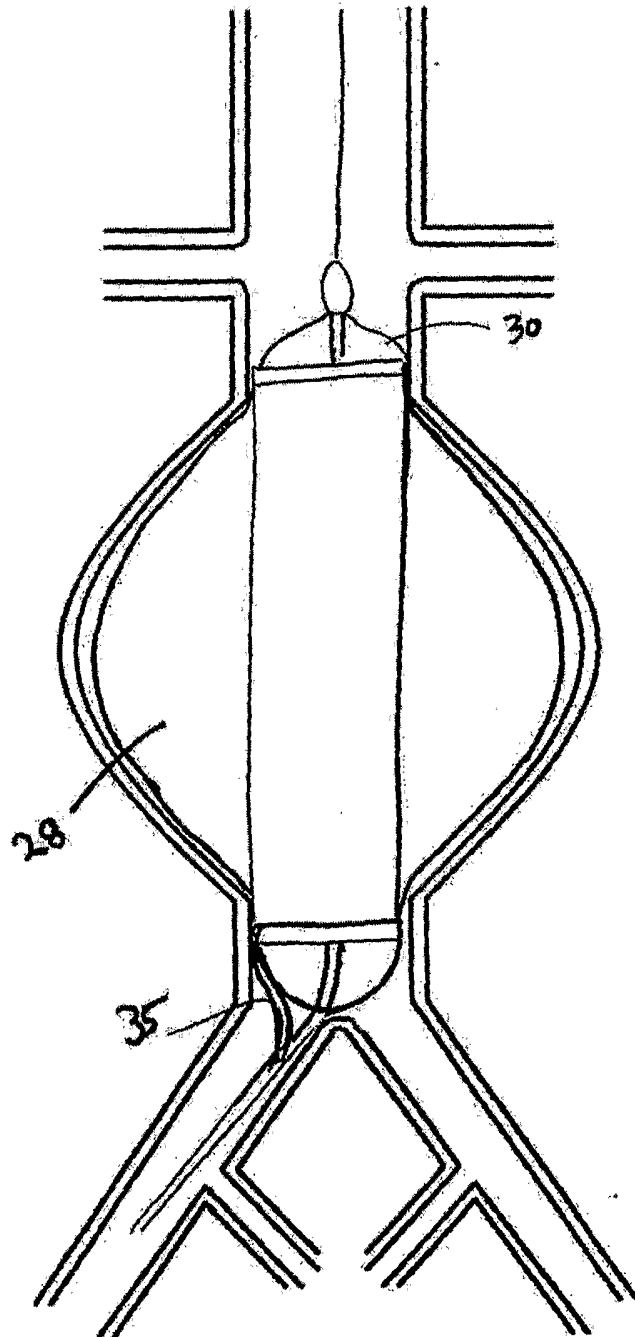

FIGURE 21D

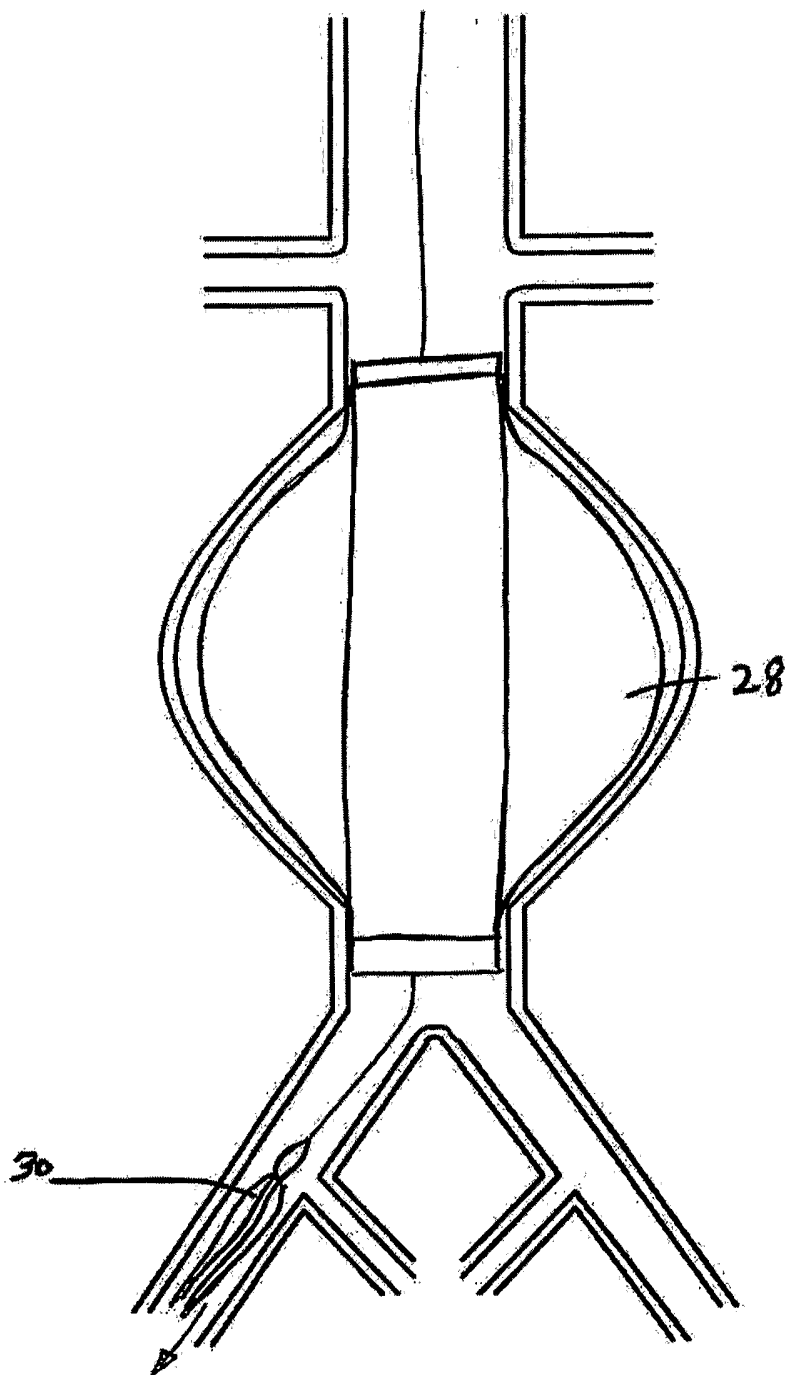

FIGURE 21E