

(19) World Intellectual Property
Organization
International Bureau



(43) International Publication Date
2 June 2005 (02.06.2005)

PCT

(10) International Publication Number
WO 2005/048863 A1

- (51) International Patent Classification⁷: **A61B 18/18**
- (21) International Application Number:
PCT/US2004/037680
- (22) International Filing Date:
10 November 2004 (10.11.2004)
- (25) Filing Language: English
- (26) Publication Language: English
- (30) Priority Data:
10/713,490 14 November 2003 (14.11.2003) US
10/713,341 14 November 2003 (14.11.2003) US
- (71) Applicant (for all designated States except US): **STAR-ION INSTRUMENTS CORPORATION** [US/US]; 20665 Fourth Street, Saratoga, CA 95070 (US).
- (72) Inventors; and
- (75) Inventors/Applicants (for US only): **MCGAFFIGAN, Thomas, H.** [US/US]; 20665 Fourth Street, Saratoga, CA 95070 (US). **ECHEVERRY, Jan, M.** [US/US]; 20665 Fourth Street, Saratoga, CA 95070 (US). **BOUDIN, Donielle** [US/US]; 20665 Fourth Street, Saratoga, CA 95070 (US). **CARLOTTO, Peter** [US/US]; 20665 Fourth Street, Saratoga, CA 95070 (US). **LE, Huy** [US/US]; 20665 Fourth Street, Saratoga, CA 95070 (US).
- (74) Agent: **CROCKETT, David, K.**; Crockett & Crockett, 24012 Calle De La Plata, Suite 400, Laguna Hills, CA 92653 (US).
- (81) Designated States (unless otherwise indicated, for every kind of national protection available): AE, AG, AL, AM, AT, AU, AZ, BA, BB, BG, BR, BW, BY, BZ, CA, CH, CN, CO, CR, CU, CZ, DE, DK, DM, DZ, EC, EE, EG, ES, FI, GB, GD, GE, GH, GM, HR, HU, ID, IL, IN, IS, JP, KE, KG, KP, KR, KZ, LC, LK, LR, LS, LT, LU, LV, MA, MD, MG, MK, MN, MW, MX, MZ, NA, NI, NO, NZ, OM, PG, PH, PL, PT, RO, RU, SC, SD, SE, SG, SK, SL, SY, TJ, TM, TN, TR, TT, TZ, UA, UG, US, UZ, VC, VN, YU, ZA, ZM, ZW.
- (84) Designated States (unless otherwise indicated, for every kind of regional protection available): ARIPO (BW, GH, GM, KE, LS, MW, MZ, NA, SD, SL, SZ, TZ, UG, ZM, ZW), Eurasian (AM, AZ, BY, KG, KZ, MD, RU, TJ, TM), European (AT, BE, BG, CH, CY, CZ, DE, DK, EE, ES, FI, FR, GB, GR, HU, IE, IS, IT, LU, MC, NL, PL, PT, RO, SE, SI, SK, TR), OAPI (BF, BJ, CF, CG, CI, CM, GA, GN, GQ, GW, ML, MR, NE, SN, TD, TG).

Published:
— with international search report

For two-letter codes and other abbreviations, refer to the "Guidance Notes on Codes and Abbreviations" appearing at the beginning of each regular issue of the PCT Gazette.

(54) Title: THERMAL CAUTERY DEVICES WITH IMPROVED HEATING PROFILES AND METHOD OF TESTING THERMAL CAUTERY DEVICES

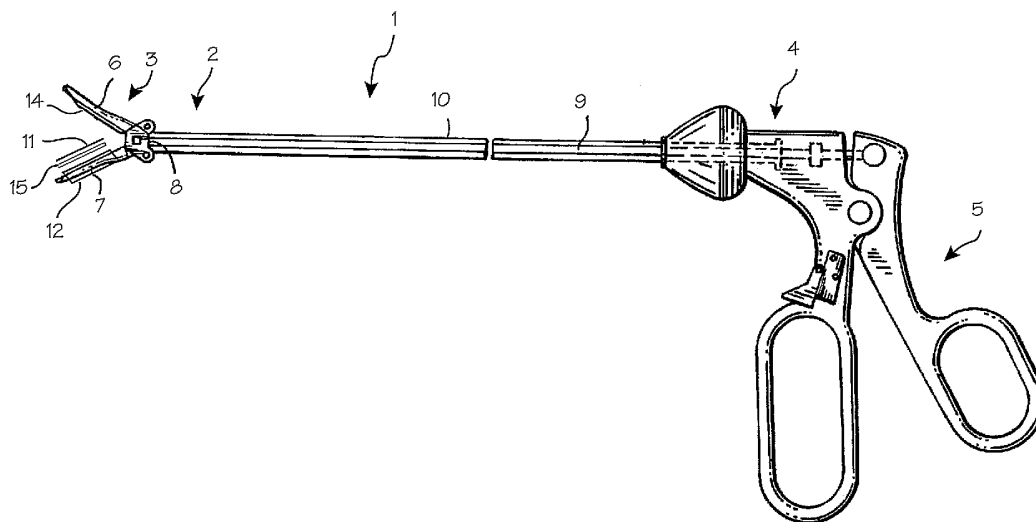

(57) Abstract: Thermal cautery and thermal ligating devices (1) improved by the addition of a thermally conductive plate proximate the resistive heating element (11) used in those devices.

WO 2005/048863 A1

THERMAL CAUTERY DEVICES WITH IMPROVED HEATING PROFILES
AND METHOD OF TESTING THERMAL CAUTERY DEVICES

Field of the Inventions

5 The inventions described below relate to instruments and
methods for sealing, joining, and cutting tissue.

Background of the Inventions

10 The devices described below provide for improved heat
transfer and sealing performance for our Starion® line of
thermal cautery forceps and thermal ligating shears, and in
instruments such as those disclosed in Treat, et al.,
Electrothermal Instrument For Sealing And Joining Or Cutting
Tissue, U.S. Patent 6,626,901 (Sep. 30, 2003) (the disclosure
of which is hereby incorporated in its entirety).

15 Summary

 The thermal cautery and thermal ligating devices
disclosed in U.S. Patent 6,626,901 are improved by the
addition of a thermally conductive plate proximate to the
resistive heating element used in those devices.

20 Brief Description of The Drawings

 Figures 1 and 2 illustrate laparoscopic thermal ligating
shears designed to provide thermal ligation and division in
numerous endoscopic procedures.

25 Figure 3 illustrates a forceps embodiment of a thermal
cautery device.

Figure 4 illustrates the prior art construction of the distal tip of a thermal cautery device.

Figures 5 and 6 are cross sections of thermal cautery or thermal ligating devices with a thermally conductive plate interposed between the resistive heating element and the grasping face of the distal tip of the grasping arm of the device.

Figure 7 illustrates the effect of the thermal cautery or thermal ligating devices on a segment of body tissue.

Figures 8 and 9 illustrate embodiments of the heating element and thermally conductive plate.

Figure 10 illustrates a method of testing the thermal cautery or thermal ligating devices.

Detailed Description of the Inventions

Figures 1 and 2 illustrate laparoscopic thermal ligating shears of the type marketed by Starion Instruments, Inc. with the improved heating assembly described below. These shears are designed to provide thermal ligation and division in numerous endoscopic procedures. The shears 1 comprises distal end 2 with remotely operable grasping assembly 3 and a proximal end 4 with a pistol grip actuator 5. The distal end is adapted for insertion into the body of a patient through a laparoscopic access port. The grasping assembly comprises small grasping arms 6 and 7, operably connected to the pistol grip actuator through the pivot section (hinge 8) and actuator rod 9 running through the rigid tube 10, such that operation of the actuator causes the grasping arms to open and close, thereby moving the respective grasping faces into apposition to each other. A resistive heating element (a heater wire or tube) 11 is fixed to the grasping face of the first grasping arm, running over the grasping face from the distal end to the

proximal end of the grasping face. The first grasping arm is also covered with a resilient, non-stick, thermally insulative sleeve 12 to provide a resilient pad 13 on the grasping face under the heater wire, between the heater wire and the grasping face. A resilient, thermally insulative sleeve 14 covers the second grasping arm to provide a resilient pad on the grasping face of the second arm. A small thermally conductive but electrically insulative plate or sheet 15 is disposed over the first grasping face, extending laterally across the grasping face and longitudinally under the heating element.

Figure 2 provides a close up view of the grasping assembly 3, showing the heater wire 11 thermally insulative sleeve 12 on the first grasping arm. Suitable materials for the sleeves and/or resilient pads include polytetrafluoroethylene (PTFE), KAPTON, mica, or silicone. Each sleeve serves to even out pressure applied to tissue and insulates the surfaces of grasping arms electrically and thermally. The thermally conductive but electrically insulative plate is visible between the heating element 11 and the resilient pad 12. As shown in the figure, the plate may be curved and contoured to match the curvature of the grasping face, which in this case is arcuate in the distal-to-proximal aspect, and rounded laterally across the grasping face. This plate serves as a heat spreader to broaden the zone of heat application as illustrated below. The plate may be constructed of a high thermal conductivity metal such as aluminum, copper (and metals of lesser thermal conductivity such as titanium) and the like, a high thermal conductivity ceramics such as boron nitride or aluminum nitride or the like, or a plastic material incorporating a high thermal conductivity metal or ceramic. If the heat spreader is constructed of a material that is an electrical conductor, the heat spreader must be electrically isolated from the resistive

heating element. Thus, if comprised of metal, the plate and resistive heating element must be electrically insulated with a high temperature electrical insulator. This may be accomplished with an electrically insulative layer formed of an oxidized surface on the metal plate, such as can be done with metals such as titanium or aluminum. These materials may be covered by a thick layer of oxide of the metal, or by anodizing the metal plate, or with an electrically non-conductive coating on the metal plate or under the resistive wire.

Figure 3 illustrates thermal cautery forceps of the type marketed by Starion Instruments, Inc. with the addition of the improved heating assembly. The forceps 21 comprises grasping arms in the form of elongate forceps arms 22 and 23 with proximal ends 24 and 25 resiliently mounted to a pivot section (handle section 26). The outer surfaces of forceps arms 22 and 23 are fitted with finger grips 27 and 28 to assist the operator in holding and activating the forceps. The opposing surfaces of the distal tips 29 and 30 of the forceps establish grasping faces which are aligned on each grasping arm so as to meet the grasping face of the other grasping arm upon closure of the grasping arms. Closure of the grasping arms is accomplished manually. The forceps arms may be formed of a suitable resilient material such as stainless steel, plastic, composites, etc. that have the desired combination of stiffness and resilience.

The distal tips include the various elements of the heating assembly. A resistive heating element (a heater wire) 34 is disposed on the grasping face of distal tip 30, secured to the distal end of the grasping arm 23 and extending proximally over the grasping face of the grasping arm toward the proximal end of the grasping arm. The distal tip 30 is also covered with a resilient, non-stick, thermally insulative

sleeve 35 to provide a resilient pad 36 on the grasping face under the heater wire, between the heater wire and the grasping face. The grasping face of the opposing distal tip 29 may also be covered by a resilient, non-stick, thermally insulative surface 37, provided as a portion of sleeve 38 disposed over the distal tip 29, in order to provide an anvil surface upon which the heating element acts during operation. The thermally conductive but electrically insulative plate 39 is disposed between the heating element 34 and the resilient pad 36.

Additional elements of the forceps are also shown in Figure 3. The a finger-operated switch 40 preferably comprises a multi-directional post-in-tube design with a control button 41 and a contact switch disposed in opposition to one of the grasping arms which is operably connected with the power supply (not shown) and the heating element such power cannot be supplied to the heating element unless the contact switch is engaged when a user squeezes the grasping arms.

Figure 4 is a cross section illustrating a prior art construction of the distal tip of a thermal cautery device, while Figure 5 is a cross section of a thermal cautery device with a thermally conductive plate interposed between the resistive heating element and the grasping face of the distal tip of the grasping arm of the device. The components of the heating assembly components shown in Figure 3 appear in both figures, with the exception of the plate 39. As discussed in reference to Figure 3, the grasping face of the distal tip 30 is covered with the resilient pad 36 (which, as illustrated, is a portion of resilient sleeve 35 (the resilient sleeve may also establish a fluid-filled (air or liquid) gap over the outer surface of the distal tip, which helps prevent thermal damage to body tissue in the vicinity of the tissue to be

cauterized and ligated)), and the resistive heating element 34 is disposed over the grasping face, over the resilient pad, so that it is located between the grasping faces. The distal tip 29 is covered by the resilient sleeve 38 to establish the resilient pad 37 on the grasping face of this distal tip.

In addition to the structure shown in Figure 4, Figure 5 shows the placement of the plate 39, interposed between the heating element and the grasping face of the forceps arm 23. The plate is arcuate, such that it bulges away from the grasping face of forceps arm 23 along its long distal-to-proximal centerline and bows away from the opposing grasping face toward the lateral sides of the device. A typical length of body tissue 42 is shown, held between the grasping faces. In Figure 4, the extent of heat affected zone in the body tissue is indicated by arrow 43. The high heat generated by the heating wire, combined with light pressure exerted on the body tissue, results in division at line 44. In comparison, as shown in Figure 5, the extent of heat affected zone in the body tissue, when the plate 39 is used, is indicated by arrow 45. The wide lateral extent of heat affected zone results in a more secure seal of the tissue.

In Figure 6, which shows the grasping face of the distal tip 30 of the active grasping arm 23, covered by the resilient pad 36, the resistive heating element 34 disposed over the grasping face and the distal tip 29 of the opposing grasping arm with its resilient sleeve 38, along with the plate 39 interposed between the heating element and the grasping face of the active grasping arm 23. In this figure, the distal tip 30 of the active grasping arm 23 is cylindrical, with a substantially circular radial cross section. The resilient sleeve 35 surrounds and closely conforms to the cylindrical grasping arm, and the thermally conductive plate 39 is semi-cylindrical, and is disposed over the sleeve, between the

sleeve and the resistive heating element. This embodiment provides for improved contact between the heat spreader and thicker tissues. The resultant divided tissue is shown in Figure 7, which shows the small area of division on either side of line 44, and the wide lateral extent of thermally sealed tissue boundaries 46 and 47.

Figures 8 and 9 illustrate the heating element and thermally conductive plate in additional detail. Figure 8 illustrates the laterally arcuate shape of the plate 39, with a round wire heating element 34 overlying the plate. Figure 9 illustrates an oval cross-section wire heating element 51 physically and thermally intimate with or joined to the plate with channel beam 52. The channel beam and plate of Figure 9 may be integrally formed, or formed of discrete components.

The plate greatly increases the amount of heat energy that can be delivered to the tissue prior to cutting the tissue. This increases the seal size (the amount of tissue that is sealed) and the integrity of the seal. With direct contact between the heating element and the thermally conductive plate, sufficient heat energy is conducted to the thermally conductive plate to heat the entire plan area of the tissue in contact with the thermally conductive plate to sealing temperatures. Sealing temperatures, which are generally between 60°C and 100°C, are achieved quickly because of the intimate contact between the heating element and the thermally conductive plate and the high thermal conductivity of the thermally conductive plate. Thermally isolating the thermally conductive plate from the forceps arms (a function provided by the sleeve) adds to the ability of the thermally conductive plate to quickly come up to temperature. The thermal resistance between the heating element and the thermally conductive plate results in temperatures that are always lower in the thermally conductive plate than in the

heating element. This promotes tissue sealing in the thermally conductive plate area and tissue cutting in the heating element area. An added benefit of the thermally conductive plate is that it promotes even heating element temperatures due to increasing the effective longitudinal thermal conductivity of the heating element. Because the heating element and the thermally conductive plate are in intimate contact with very little thermal resistance between them the heating element longitudinal thermal conductivity is effectively improved because of the good longitudinal conductivity of the thermally conductive plate. This is very important when the heating element has uneven heat loads, as is usually the case. The high thermal conductivity of the thermally conductive plate allows it to transfer heat from one portion of the heating element to another colder portion of the heating element/thermally conductive plate assembly. This action pulls up the temperatures in the low spots and brings down the temperatures in the high spots. Bringing down the high temperatures is a benefit as very high temperatures, such as those in excess of 500°C, are undesirable. If temperatures below 300° C are maintained, non-stick components such as PTFE or ePTFE (Teflon®) coatings will survive for the life of the device. Temperatures in excess of 300°C will quickly destroy these components, and temperatures in excess of 600°C may melt an aluminum heat spreader.

Current Starion® device heating element plan areas are 0.022" wide by 0.75" long or 0.010" wide by 0.750" long. Using the thermally conductive plate with these existing heating elements, at power level of about 10 watts, results in heated plan areas which can be increased by 5 times or more over the prior device. Heat spreader dimensions of 0.065 to .100" wide have proven effective in testing.

Dimensions of the various components and the appropriate power levels for the thermal cautery devices incorporating the heating element and heat spreader have been developed through testing on natural live tissue which closely approximates the sealing behavior of vascularized human body tissue.

5 Specifically, live earthworms have been used in testing to develop the heat spreader design, thus making it quite convenient and inexpensive to test prototypes as necessary to optimize the geometry and material characteristics of the various components. As illustrated in Figure 9, live red worms **53** of 2 to 5 mm diameter (approximating the thickness of tissues of interest such as veins and arteries) were sealed and divided, at positions between the clitellum **54** and the mouth **55**. Prior to testing with the new devices, a number of earthworms in various conditions were tested with Starion® cautery forceps with well known effect on human and animal body tissue (having been tested with more expensive and burdensome animal testing and having been used commercially for some time) to determine their suitability. The earth worms proved to accurately model the response of live human tissue. To test the effectiveness of the thermal cautery devices, and to devise optimum component sizes and materials, live earth worms were sealed and divided with thermal cautery devices of various design. Earth worms of about 2 to 5 mm in diameter were used to model human vessels of 2 to 5 mm in diameter. The effectiveness of the thermal cautery devices was judged by the lateral extent of the sealed tissue, the width of the division (vaporized tissue at the line of division, and seal strength. The strength of the seal was judged by dividing a worm at two locations to form a worm segment with seals at both ends, and then pressurizing the worm segment to ascertain that certain predetermined internal pressure would overcome the seal. Successful sealing and division of the earth worm models translated directly into

successful sealing and division of animal and human tissue. The use of the earth worm as a model for tissue in the testing of cautery devices thus provides an inexpensive and convenient method of bench testing cautery devices. The method may be used with cautery devices comprising the resistive heating element and heat spreader disclosed above, RF cautery devices, and various other means for thermally affecting body tissue.

In use, the thermal cautery device is manipulated to grasp body tissue, such as a blood vessel, a small section of fat, or other tissue as necessitated by the desired surgery. With the grasping arms on either side of the target tissue, surgeons gently close the grasping arms or forceps, as the case may be, to bring the grasping faces into apposition, with the target tissue held between the faces. While applying pressure to the tissue with the grasping faces, the surgeon energizes the device to provide a DC current to the heating wire. The heating wire itself heats up to temperatures above about 200°C, thus vaporizing the tissue immediately between the heating wire and the opposing grasping face (and a small lateral extent of tissue). Heat is applied for a period of time, in the range of 5 seconds to 20 seconds, thus allowing heat from the heating element to conductively heat the heat spreader plate. Heat from the heat spreader plate, which typically reaches temperatures of 60°C to 100°C, is thereby applied to the tissue trapped between the heat spreader plate and the opposing grasping face, resulting in a thermal seal of the tissue with a width closely corresponding to the plan area of the plate (less the small vaporized section).

The improvements to the thermal cautery device have been described in relation to laparoscopic ligation devices and forceps devices, but they may be applied to open surgical forceps and clamps, catheter-based devices, and various other embodiments of thermal cautery and thermal ligation devices.

Thus, while the preferred embodiments of the devices and methods have been described in reference to the environment in which they were developed, they are merely illustrative of the principles of the inventions. Other embodiments and
5 configurations may be devised without departing from the spirit of the inventions and the scope of the appended claims.

We claim:

1. A surgical device comprising:

5 first and second grasping arms extending from a pivot section, said first and second grasping arms being resiliently mounted to the pivot section to allow closure of the grasping arms, said first and second grasping arms each having a distal end with a grasping face, said grasping face on each grasping arm aligned to meet the grasping face of the other grasping arm upon closure of the grasping arms;

10

a resistive heating element disposed upon the grasping face of the first grasping arm so that it lies between the grasping face of the first grasping arm and the grasping face of the second grasping arm upon closure of the grasping arms, said resistive heating element being operably connected to a source of electrical power; and

15

a thermally conductive plate disposed between the resistive heating element and the grasping face of the first grasping arm.

20

2. The device of claim 1 wherein the plate is 0.065 to .100 inches wide.

3. The device of claim 1 further comprising an electrically insulative layer disposed between the resistive heating element and the plate.

25

4. The device of claim 3 wherein the electrically insulative layer comprises a coating on the thermally conductive plate.

5. The device of claim 3 wherein the thermally conductive plate comprises a metal and the electrically insulative layer comprises an oxide of the metal.

6. The device of claim 3 wherein the thermally conductive plate and electrically insulative layer comprise an anodized metal plate.

7. The device of claim 1 wherein the thermally conductive plate comprises a thermally conductivity ceramic.

8. The device of claim 1 wherein the thermally conductive plate comprises a plastic incorporating a high thermal conductivity metal or ceramic.

9. The device of claim 1 wherein the thermally conductive plate is arcuate relative to the transverse cross section of the grasping arms.

10. The device of claim 1, wherein the grasping face of the first grasping arm is substantially convex and the plate is substantially semi-cylindrical.

11. The device of claim 1, wherein the first grasping arm is substantially cylindrical and the plate is substantially semi-cylindrical.

12. The device of claim 1 further comprising:

a resilient surface on the grasping face of the first grasping arm, between the thermally conductive plate and the grasping face of the arm.

13. The device of claim 1 further comprising:

a thermally insulative surface on the grasping face of the first grasping arm, between the thermally conductive plate and the grasping face of the arm.

14. The device of claim 1 further comprising:

a sleeve covering the distal end of the first grasping arm, thereby forming a thermally insulative surface on the grasping face of the second grasping arm.

5 15. The device of claim 1 further comprising:

a resilient sleeve covering the distal end of the second grasping arm, thereby forming a resilient surface on the grasping face of the second grasping arm.

16. The device of claim 1 further comprising:

10 a resilient surface on the grasping face of each of the first and second grasping arms.

17. The device of claim 1 further comprising:

15 a sleeve covering the distal end of the first grasping arm, thereby forming a surface on the grasping face of the first grasping arm, between the wire and the grasping face of the arm, and

a resilient sleeve covering the distal end of the second grasping arm, thereby forming a resilient surface on the grasping face of the second grasping arm.

20 18. The device of claim 1 wherein the grasping arms and pivot section comprise a pair of tweezers.

19. The device of claim 1 wherein the grasping arms and pivot section comprise a forceps.

25 20. The device of claim 1 wherein the grasping arms and pivot section are mounted on a rod adapted for insertion into the body through a laparoscopic access port, and said device further comprises a handle section operably connected to the

pivot section and grasping arms for remotely operating the grasping faces within the body.

21. A medical device comprising:

5 a pair of tweezers characterized by a first arm and a second arm, each of said arm having a proximal end and distal end, said first arm having a first gripping face disposed on the distal end thereof, said second arm having second gripping face disposed on the distal end thereof, said gripping faces being defining surfaces generally perpendicular to a plane defined by the grasping arms, said surfaces being movable into apposition with each other upon closing of the tweezers;

15 a first layer of resilient material disposed on the gripping face of the first arm;

a second layer of resilient material disposed on the gripping face of the second arm;

20 a resistive heating element disposed between of the first and second layers of resilient material so as to be trapped between the gripping faces of the first and second arm upon closing of the tweezers; and

a thermally conductive plate disposed between the resistive heating element and a gripping face of the first arm.

25 22. The device of claim 9 wherein the plate is 0.065 to .100 inches wide.

23. The device of claim 22 further comprising an electrically insulative layer disposed between the resistive heating element and the plate.

24. The device of claim 23 wherein the electrically insulative layer comprises a coating on the thermally conductive plate.

25. The device of claim 23 wherein the thermally conductive plate comprises a metal and the electrically insulative layer comprises an oxide of the metal.

26. The device of claim 23 wherein the thermally conductive plate and electrically insulative layer comprise an anodized metal plate.

27. The device of claim 21 wherein the thermally conductive plate comprises a thermally conductivity ceramic.

28. The device of claim 21 wherein the thermally conductive plate comprises a plastic incorporating a high thermal conductivity metal or ceramic.

29. The device of claim 21 wherein the thermally conductive plate is arcuate relative to the transverse cross section of the grasping arms.

30. The device of claim 21, wherein the grasping face of the first grasping arm is substantially convex and the plate is substantially semi-cylindrical.

31. The device of claim 21, wherein the first grasping arm is substantially cylindrical and the plate is substantially semi-cylindrical.

32. The device of claim 21 further comprising:

a sleeve covering the distal end of the first grasping arm, thereby forming a thermally insulative surface on the grasping face of the second grasping arm.

33. The device of claim 21 further comprising:

a resilient sleeve covering the distal end of the second grasping arm, thereby forming a resilient surface on the grasping face of the second grasping arm.

5 34. The device of claim 21 further comprising:

a resilient surface on the grasping face of each of the first and second grasping arms.

35. The device of claim 21 further comprising:

10 a sleeve covering the distal end of the first grasping arm, thereby forming a surface on the grasping face of the first grasping arm, between the wire and the grasping face of the arm, and

15 a resilient sleeve covering the distal end of the second grasping arm, thereby forming a resilient surface on the grasping face of the second grasping arm.

36. A medical device comprising:

20 a pair of forceps characterized by a first arm and a second arm, each of said arms having a proximal end and distal end, each of said arms being rotatably fixed to the other at a midpoint thereof, said first arm having a first gripping face disposed on the distal end thereof, said second arm having second gripping face disposed on the distal end thereof, said gripping faces being defining surfaces generally perpendicular to a
25 plane defined by the grasping arms, said surfaces being movable into apposition with each other upon closing of the forceps;

a first layer of resilient material disposed on the gripping face of the first arm;

a second layer of resilient material disposed on the gripping face of the second arm;

5 a resistive heating element disposed between of the first and second layers of resilient material so as to be trapped between the gripping faces of the first and second arm upon closing of the forceps and

10 a thermally conductive plate disposed between the resistive heating element and the gripping face of the first arm.

37. The device of claim 36 wherein the plate is 0.065 to .100 inches wide.

15 38. The device of claim 36 further comprising an electrically insulative layer disposed between the resistive heating element and the plate.

39. The device of claim 38 wherein the electrically insulative layer comprises a coating on the thermally conductive plate.

20 40. The device of claim 38 wherein the thermally conductive plate comprises a metal and the electrically insulative layer comprises an oxide of the metal.

25 41. The device of claim 38 wherein the thermally conductive plate and electrically insulative layer comprise an anodized metal plate.

42. The device of claim 36 wherein the thermally conductive plate comprises a thermally conductivity ceramic.

43. The device of claim 36 wherein the thermally conductive plate comprises a plastic incorporating a high thermal conductivity metal or ceramic.

44. The device of claim 36 wherein the thermally conductive plate is arcuate relative to the transverse cross section of the grasping arms.

45. The device of claim 36, wherein the grasping face of the first grasping arm is substantially convex and the plate is substantially semi-cylindrical.

46. The device of claim 36, wherein the first grasping arm is substantially cylindrical and the plate is substantially semi-cylindrical.

47. The device of claim 36 further comprising:

a sleeve covering the distal end of the first grasping arm, thereby forming a thermally insulative surface on the grasping face of the second grasping arm.

48. The device of claim 36 further comprising:

a resilient sleeve covering the distal end of the second grasping arm, thereby forming a resilient surface on the grasping face of the second grasping arm.

49. The device of claim 36 further comprising:

a resilient surface on the grasping face of each of the first and second grasping arms.

50. The device of claim 36 further comprising:

a sleeve covering the distal end of the first grasping arm, thereby forming a surface on the grasping face of the first grasping arm, between the wire and the grasping face of the arm, and

a resilient sleeve covering the distal end of the second grasping arm, thereby forming a resilient surface on the grasping face of the second grasping arm.

51. A medical device comprising:

5 a laparoscopic grasper characterized by a first arm and a second arm, each of said arm having a proximal end and distal end, each of said arm being rotatably relative to the other about a point near the distal end thereof, said arms being adapted to be inserted into the body
10 and to be rotatably opened and closed upon each other within the body, said first arm having a first gripping face disposed on the distal end thereof, said second arm having second gripping face disposed on the distal end thereof, said gripping faces being defining
15 surfaces generally perpendicular to a plane defined by the grasping arms, said surfaces being movable into apposition with each other upon closing of the graspers;

20 a first layer of resilient material disposed on the gripping face of the first arm;

a second layer of resilient material disposed on the gripping face of the second arm;

25 a wire disposed between of the first and second layers of resilient material so as to be trapped between the gripping faces of the first and second arm upon closing of the graspers and

a thermally conductive plate disposed between the resistive heating element and the gripping face of the first arm.

52. The device of claim 51 wherein the plate is 0.065 to .100 inches wide.

53. The device of claim 51 further comprising an electrically insulative layer disposed between the resistive heating
5 element and the plate.

54. The device of claim 53 wherein the electrically insulative layer comprises a coating on the thermally conductive plate.

55. The device of claim 53 wherein the thermally conductive
10 plate comprises a metal and the electrically insulative layer comprises an oxide of the metal.

56. The device of claim 53 wherein the thermally conductive plate and electrically insulative layer comprise an anodized metal plate.

15 57. The device of claim 51 wherein the thermally conductive plate comprises a thermally conductivity ceramic.

58. The device of claim 51 wherein the thermally conductive plate comprises a plastic incorporating a high thermal conductivity metal or ceramic.

20 59. The device of claim 51 wherein the thermally conductive plate is arcuate relative to the transverse cross section of the grasping arms.

60. The device of claim 51, wherein the grasping face of the first grasping arm is substantially convex and the plate is
25 substantially semi-cylindrical.

61. The device of claim 51, wherein the first grasping arm is substantially cylindrical and the plate is substantially semi-cylindrical.

62. The device of claim 51 further comprising:

a sleeve covering the distal end of the first grasping arm, thereby forming a thermally insulative surface on the grasping face of the second grasping arm.

5 63. The device of claim 51 further comprising:

a resilient sleeve covering the distal end of the second grasping arm, thereby forming a resilient surface on the grasping face of the second grasping arm.

64. The device of claim 51 further comprising:

10 a resilient surface on the grasping face of each of the first and second grasping arms.

65. The device of claim 51 further comprising:

15 a sleeve covering the distal end of the first grasping arm, thereby forming a surface on the grasping face of the first grasping arm, between the wire and the grasping face of the arm, and

a resilient sleeve covering the distal end of the second grasping arm, thereby forming a resilient surface on the grasping face of the second grasping arm.

20 66. A surgical instrument comprising two oppositely-positioned grasping arms each having a grasping face, wherein at least one grasping arm has an resistive heating element thereon, the electrically resistant heating element being operable to divide and seal body tissue, and a thermally
25 conductive plate disposed between the resistive heating element and the grasping face of the grasping arm.

67. The device of claim 66 wherein the plate is 0.065 to .100 inches wide.

68. The device of claim 66 further comprising an electrically insulative layer disposed between the resistive heating element and the plate.

69. The device of claim 68 wherein the electrically insulative layer comprises a coating on the thermally conductive plate.

70. The device of claim 68 wherein the thermally conductive plate comprises a metal and the electrically insulative layer comprises an oxide of the metal.

71. The device of claim 68 wherein the thermally conductive plate and electrically insulative layer comprise an anodized metal plate.

72. The device of claim 66 wherein the thermally conductive plate comprises a thermally conductivity ceramic.

73. The device of claim 66 wherein the thermally conductive plate comprises a plastic incorporating a high thermal conductivity metal or ceramic.

74. The device of claim 66 wherein the thermally conductive plate is arcuate relative to the transverse cross section of the grasping arms.

75. The device of claim 66, wherein the grasping face of the first grasping arm is substantially convex and the plate is substantially semi-cylindrical.

76. The device of claim 66, wherein the first grasping arm is substantially cylindrical and the plate is substantially semi-cylindrical.

77. The device of claim 66 further comprising a resilient surface on the grasping face of the first grasping arm,

between the thermally conductive plate and the grasping face of the arm.

78. The device of claim 66 further comprising a thermally insulative surface on the grasping face of the first grasping arm, between the thermally conductive plate and the grasping face of the arm.

79. The device of claim 66 further comprising a sleeve covering the distal end of the first grasping arm, thereby forming a thermally insulative surface on the grasping face of the second grasping arm.

80. The device of claim 66 further comprising a resilient sleeve covering the distal end of the second grasping arm, thereby forming a resilient surface on the grasping face of the second grasping arm.

81. The device of claim 66 further comprising a resilient surface on the grasping face of each of the first and second grasping arms.

82. The device of claim 66 further comprising a sleeve covering the distal end of the first grasping arm, thereby forming a surface on the grasping face of the first grasping arm, between the wire and the grasping face of the arm, and

a resilient sleeve covering the distal end of the second grasping arm, thereby forming a resilient surface on the grasping face of the second grasping arm.

83. The device of claim 66 wherein the grasping arms and pivot section comprise a pair of tweezers.

84. The device of claim 66 wherein the grasping arms and pivot section comprise a forceps.

85. The device of claim 66 wherein the grasping arms and pivot section are mounted on a rod adapted for insertion into the body through a laparoscopic access port, and said device further comprises a handle section operably connected to the pivot section and grasping arms for remotely operating the grasping faces within the body.
86. The surgical instrument of claim 66, wherein the electrically resistant heating element is adapted to heat tissue without passing current through the tissue.
87. The surgical instrument of claim 66, wherein the electrically resistant heating element is adapted to heat tissue without relying on ohmic heating of the tissue.
88. The surgical instrument of claim 66, wherein the heating element has an ohmic resistance lower than the ohmic resistance of body tissue.
89. The surgical instrument of claim 66, wherein the heating element comprises an electrically resistant wire.
90. The surgical instrument of claim 66, wherein an operative area of the heating element is electrically insulated from at least one of the grasping arms.
91. The surgical instrument of claim 66, wherein an operative area of the heating element is electrically insulated from the working surface of at least one of the grasping arms.
92. The surgical instrument of claim 66, further comprising an insulator between an operative area of the heating element and at least one of the grasping arms.
93. The surgical instrument of claim 66, wherein the heating element is thermally insulated from the grasping arms.

94. The surgical instrument of claim 66, wherein the heating element is adapted both to seal and to cut tissue.

95. The surgical instrument of claim 66, wherein the instrument is adapted to cut tissue adjacent to the heating element and to seal tissue on either side of the heating element.

96. The surgical instrument of claim 66, wherein the grasping arms are electrically insulated from one another.

97. The surgical instrument of claim 66, further comprising a heating element actuator that is responsive to a pre-determined pressure to activate the heating element.

98. The surgical instrument of claim 66, wherein the heating element and the opposing working surfaces apply pressure on tissue positioned between the grasping arms as the device is closed.

99. The surgical instrument of claim 66, wherein at least one of the working surfaces comprises a non-stick material.

100. The surgical instrument of claim 66, wherein at least one of the working surfaces is textured.

101. The surgical instrument of claim 92, wherein the insulator evens out the pressure on the tissue disposed between the grasping arms.

102. The surgical instrument of claim 92, wherein the insulator comprises a sleeve at the distal end of one or both grasping arms.

103. The surgical instrument of claim 92, wherein the insulator comprises a non-stick polymeric material.

104. The surgical instrument of claim 92, wherein the insulator prevents heat dissipation and focuses heat on the tissue disposed therebetween.

105. The surgical instrument of claim 66, wherein the heating element uses one of the grasping arms as an electrical conductor.

106. The surgical instrument of claim 66, wherein the heating element loops around the distal end of the grasping arm.

10 107. A method of testing surgical devices comprising:

providing a surgical device, said surgical device comprising means for thermally affecting body tissue of a human;

providing an earth worm as a model of human body tissue;

15 applying the surgical device to the earth worm and applying power to the device to thermally affect the earth worm;

determining the suitability of the device for use on human body tissue based on the observed effect on the earth worm.

20 108. The method of claim 107 further comprising the steps of:

providing the surgical device with first and second grasping arms adapted for closure about a section of human body tissue, said first and second grasping arms each having a grasping face, said grasping face on each grasping arm aligned to meet the grasping face of the other grasping arm upon closure of the grasping arms; wherein the means for thermally affecting body tissue

comprises a means for applying energy to the human body tissue disposed between the grasping faces;

grasping the earth worm between the first and second grasping faces;

5 applying energy to the earth worm through the means for applying energy to thermally affect the earth worm.

109. The method of claim 108, wherein the step of providing a means for applying energy comprises providing a resistive heating element disposed proximate the grasping face of the
10 first grasping arm so that it lies between the grasping face of the first grasping arm and the grasping face of the second grasping arm upon closure of the grasping arms, said resistive heating element being operably connected to a source of electrical power.

15 110. The method of claim 109, where in the step of providing means for applying energy further comprises providing a thermally conductive plate between the resistive heating element and one of the grasping arms.

20 111. The method of claim 106, 107, 108 or 109 further comprising the step of grasping the earth worm between the clitellum and mouth of the earth worm.

112. The method of claim 106, 107, 108 or 109 further comprising the step of modifying a component of the device based on the observed effect of the device on the earth worm.

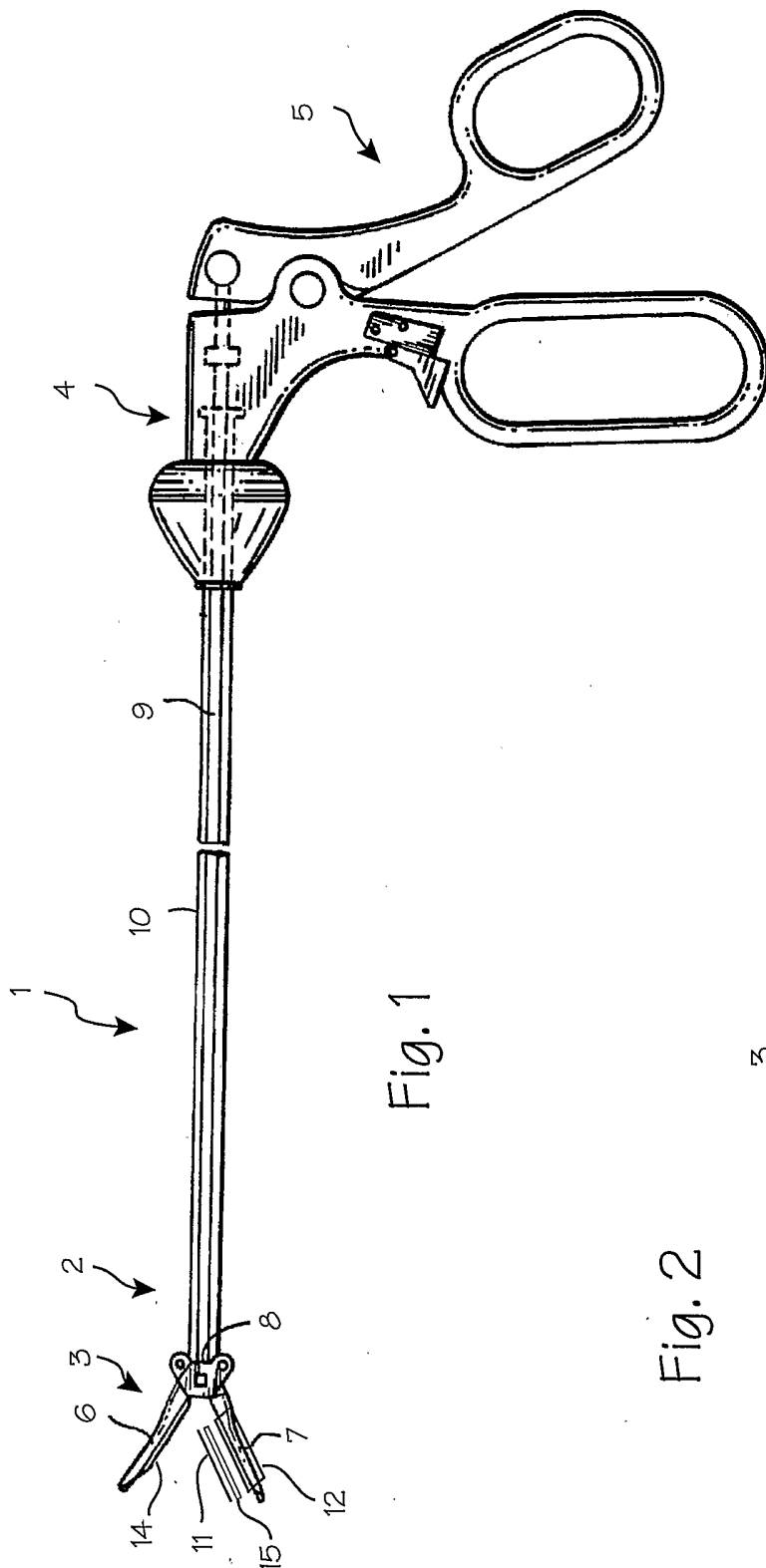

Fig. 1

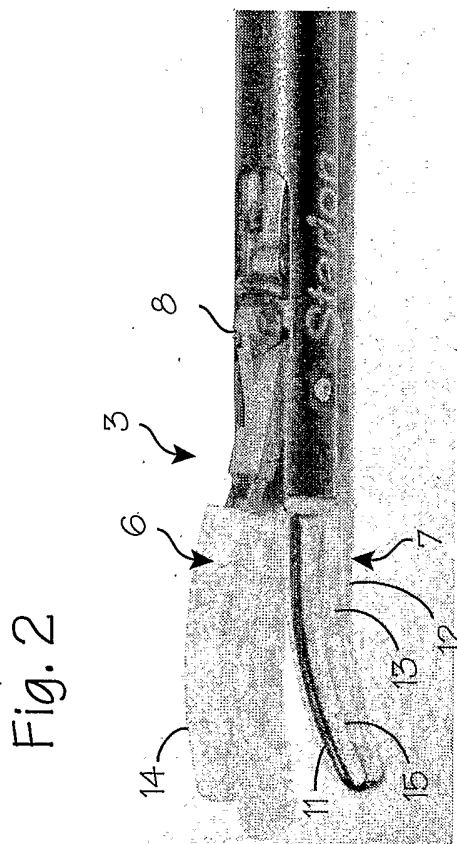

Fig. 2

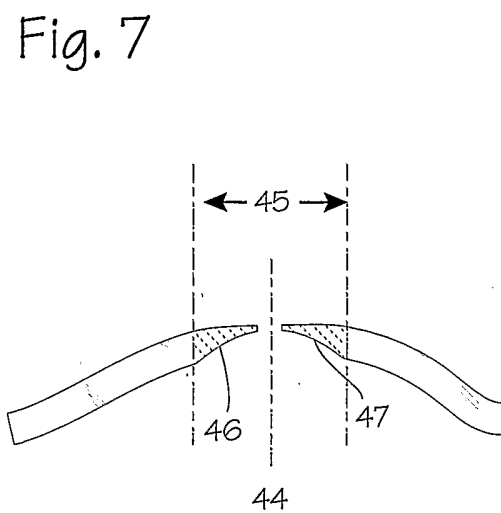
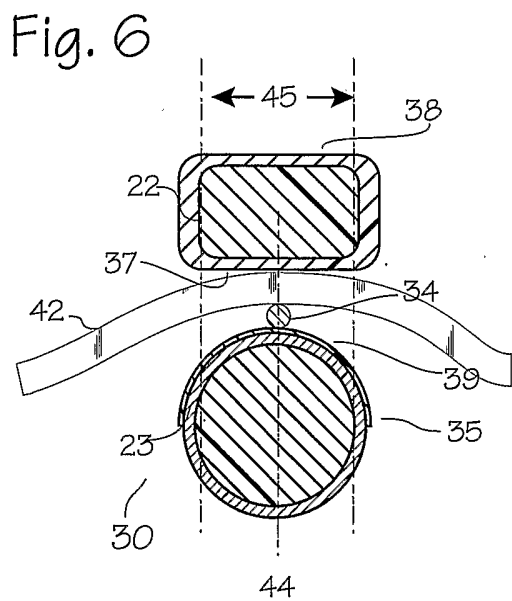
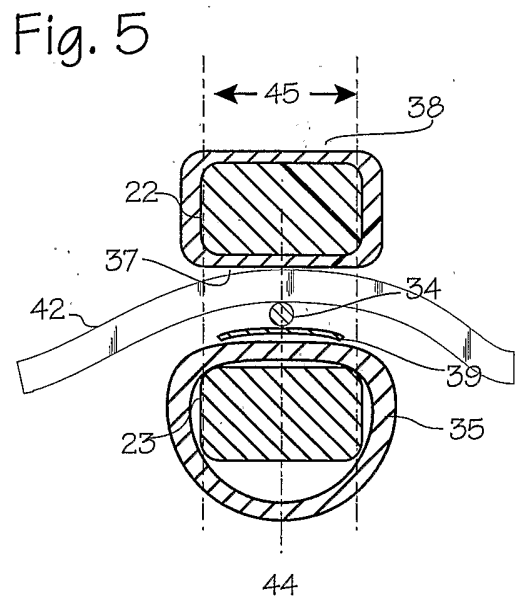
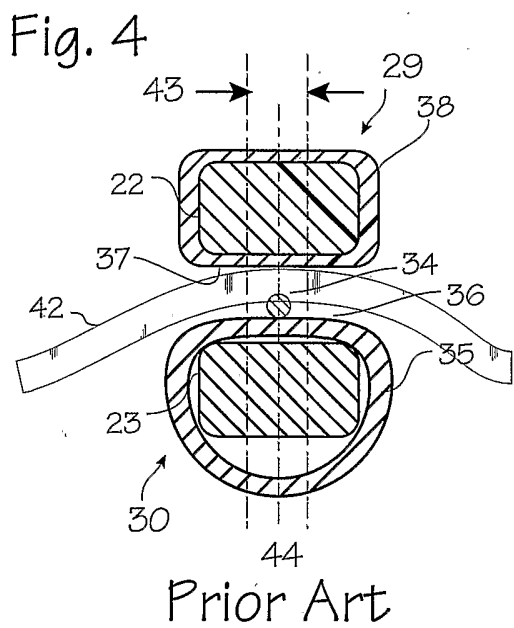
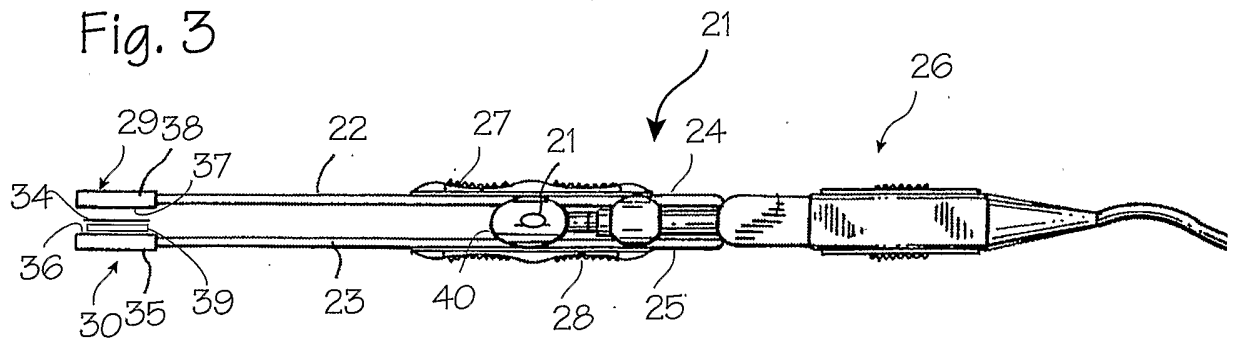

Fig. 8

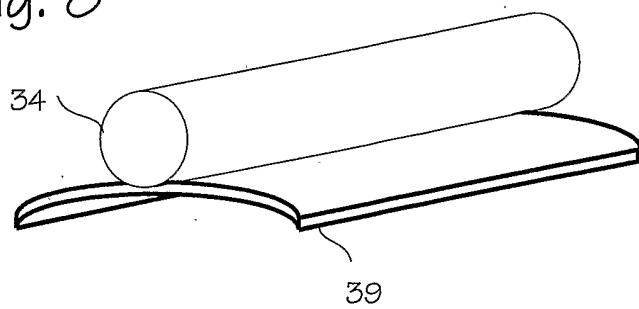

Fig. 9

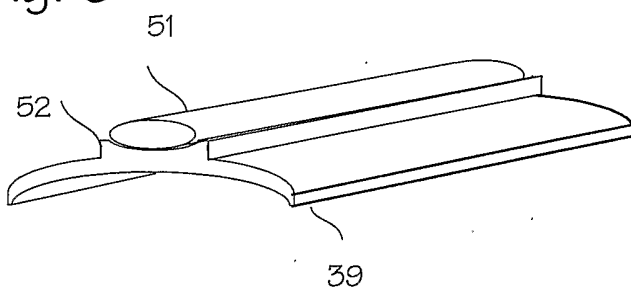
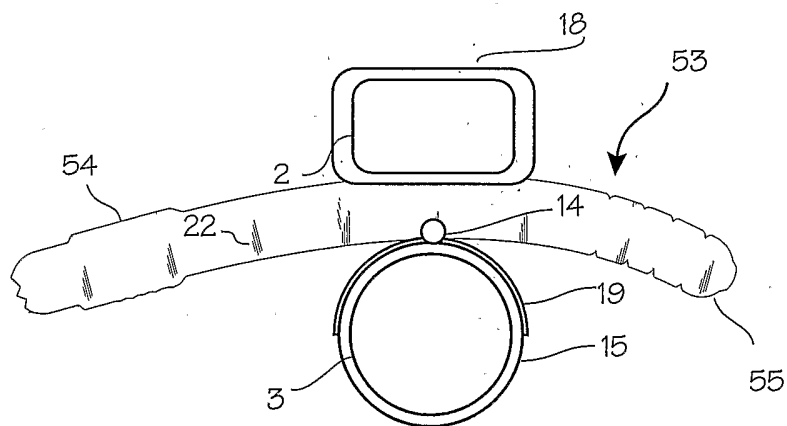

Fig. 10



INTERNATIONAL SEARCH REPORT

International application No.

PCT/US04/37680

A. CLASSIFICATION OF SUBJECT MATTER IPC(7) : A61 B 18/18 US CL : 606/29 According to International Patent Classification (IPC) or to both national classification and IPC		
B. FIELDS SEARCHED Minimum documentation searched (classification system followed by classification symbols) U.S. : 606/27-52 Documentation searched other than minimum documentation to the extent that such documents are included in the fields searched Electronic data base consulted during the international search (name of data base and, where practicable, search terms used)		
C. DOCUMENTS CONSIDERED TO BE RELEVANT		
Category *	Citation of document, with indication, where appropriate, of the relevant passages	Relevant to claim No.
Y	US 4,686,980 A(Williams et al.) 18 August 1987 (18.08.1987), entire document.	21-35
Y	US 5,496,317 A (Goble et al.) 05 March 1996 (05.03.1996), entire document.	35-65
Y	US 5,766,166 A(Hooven et al.) 16 June 1998 (16.06.1998), entire document.	1-106
Y	US 5,893,846 A(Bales et al.) 13 April 1999 (13.04.1999), entire document.	1-106
Y	US 6,221,069 B1 (Daikuzono et al.) 24 April 2004 (24.04.2004), entire document.	35-65
Y	US 5,704,377 A(McMullen) 06 January 1998 (06.01.1998), entire document.	1-106
<input type="checkbox"/> Further documents are listed in the continuation of Box C. <input type="checkbox"/> See patent family annex.		
* Special categories of cited documents:		
"A" document defining the general state of the art which is not considered to be of particular relevance	"T" later document published after the international filing date or priority date and not in conflict with the application but cited to understand the principle or theory underlying the invention	
"E" earlier application or patent published on or after the international filing date	"X" document of particular relevance; the claimed invention cannot be considered novel or cannot be considered to involve an inventive step when the document is taken alone	
"L" document which may throw doubts on priority claim(s) or which is cited to establish the publication date of another citation or other special reason (as specified)	"Y" document of particular relevance; the claimed invention cannot be considered to involve an inventive step when the document is combined with one or more other such documents, such combination being obvious to a person skilled in the art	
"O" document referring to an oral disclosure, use, exhibition or other means	"&" document member of the same patent family	
"P" document published prior to the international filing date but later than the priority date claimed		
Date of the actual completion of the international search 02 February 2005 (02.02.2005)	Date of mailing of the international search report 11 MAR 2005	
Name and mailing address of the ISA/US Mail Stop PCT, Attn: ISA/US Commissioner for Patents P.O. Box 1450 Alexandria, Virginia 22313-1450 Facsimile No. (703) 305-3230	Authorized officer <i>Linda C Dvorak</i> Telephone No. 703 308 0858	