

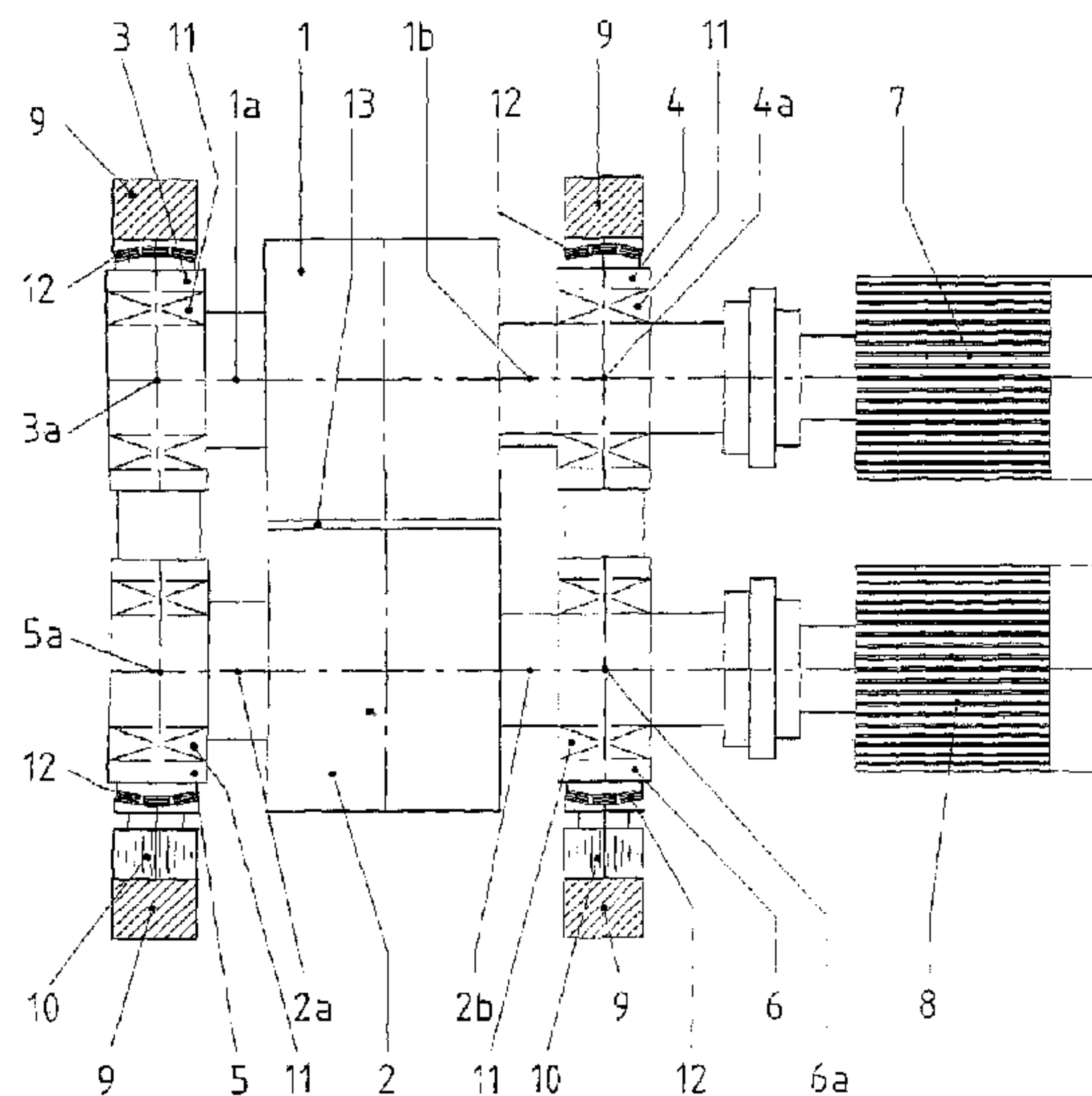

(22) Date de dépôt/Filing Date: 2011/10/06
(41) Mise à la disp. pub./Open to Public Insp.: 2012/04/14
(45) Date de délivrance/Issue Date: 2018/04/10
(30) Priorité/Priority: 2010/10/14 (DE10 2010 038 197.7)

(51) Cl.Int./Int.Cl. *B02C 4/34* (2006.01),
B02C 4/10 (2006.01)
(72) Inventeurs/Inventors:
RUETHER, THOMAS, DE;
PETERS, ALEXANDER, DE;
KOENNING, LUDWIG, DE;
HOERSTER, NILS, DE;
GIESEMANN, REINHARD, DE
(73) Propriétaire/Owner:
THYSSENKRUPP POLYSIUS AG, DE
(74) Agent: RIDOUT & MAYBEE LLP

(54) Titre : BROYEUR A CYLINDRES POUR LA FRAGMENTATION DE MATIERE A BROYER FRIABLE
(54) Title: ROLLER MILL FOR COMMUNUTING BRITTLE GRINDING STOCK



(57) **Abrégé/Abstract:**

According to a first exemplary embodiment the roller mill according to the invention for comminuting brittle grinding stock essentially consists of: at least one grinding roller rotatable about an axis of rotation, which interacts with a counter-surface in such a manner that the grinding stock is comminuted between grinding roller and counter-surface, wherein at least one grinding roller is constructed as a loose roller; bearing blocks for bearing the grinding roller, wherein the bearing blocks are horizontally slidable and are guided in the machine frame rotatably about a vertical bearing axis intersecting the axis of rotation; a pressing device supported on the machine frame in order to apply an adjustable grinding pressure to the grinding roller via the bearing blocks; and wherein at least two resilient compensation elements are associated with each bearing block in order to compensate a skewed position and/or deflection of the grinding roller, wherein the compensation elements are arranged between the machine frame and the bearing blocks. The compensation elements are - in the plan view of the roll crushing mill - arranged tangentially to a circle around the vertical bearing axis or constructed in a circular arc around the vertical bearing axis.

ABSTRACT

According to a first exemplary embodiment the roller mill according to the invention for comminuting brittle grinding stock essentially consists of: at least one grinding roller rotatable about an axis of rotation, which interacts with a counter-surface in such a manner that the grinding stock is comminuted between grinding roller and counter-surface, wherein at least one grinding roller is constructed as a loose roller; bearing blocks for bearing the grinding roller, wherein the bearing blocks are horizontally slidable and are guided in the machine frame rotatably about a vertical bearing axis intersecting the axis of rotation; a pressing device supported on the machine frame in order to apply an adjustable grinding pressure to the grinding roller via the bearing blocks; and wherein at least two resilient compensation elements are associated with each bearing block in order to compensate a skewed position and/or deflection of the grinding roller, wherein the compensation elements are arranged between the machine frame and the bearing blocks. The compensation elements are – in the plan view of the roll crushing mill – arranged tangentially to a circle around the vertical bearing axis or constructed in a circular arc around the vertical bearing axis.

ROLLER MILL FOR COMMINUTING BRITTLE GRINDING STOCK

The invention relates to a roller mill for comminuting brittle grinding stock.

The roll crushing mill with two counter-driven grinding rollers pressed against each other is a roller mill frequently used in the comminution of brittle grinding
5 stock. Here, one grinding roller is constructed with a pressing device (loose roller) and the other grinding roller is constructed without a pressing device (fixed roller) and both grinding rollers are mounted in horizontally slidable bearing blocks, wherein at least the loose roller is mounted in horizontally
10 slidable bearing blocks and the bearing blocks are rotatably guided in the machine frame about a bearing axis vertically intersecting the axis of rotation.

In a roll crushing mill with two counter-driven grinding rollers for comminuting brittle materials the two grinding rollers pressed against each other can be
15 mounted in the bearing housing by non-self-aligning cylindrical roller bearings, tapered roller bearings or sliding bearings. In operation of these roll crushing mills, the axis of rotation of the loose roller may be subject to considerable skewing. In the case of non-self-aligning types of bearing, this misalignment may lead to a distortion of the bearing housings of the loose roller in the
20 machine frame.

In addition to the distortion of the bearing housings resulting from the skewed
25 position of the axis of rotation of the loose roller, additional distortion occurs as a result of deflection of the two axes. This deflection leads to a slight distortion of the bearing housings of the fixed roller as well.

In DE 36 35 885 C2, the transmission of force between a pressing device
30 supported in the machine frame and the rotating bearing blocks is ensured by a flat rubber body of plate-like construction. In this way, any skewed positions of a bearing block are absorbed and compensated by the rubber body. The necessary sealing of the rubber body is subject to wear and tear, however,

which may lead to failure of the system. In addition, high restoring forces develop, which can lead to damage to the non-adjustable bearings.

The invention therefore addresses the problem of specifying compensation
5 elements for the bearing blocks, which have a long service life and ensure the required mobility with low restoring forces.

According to a first exemplary embodiment the roller mill according to the invention for comminuting brittle grinding stock essentially consists of

- 10 a) at least one grinding roller rotatable about an axis of rotation, which interacts with a counter-surface in such a manner that the grinding stock is comminuted between grinding roller and counter-surface, wherein at least one grinding roller is constructed as a loose roller,
- b) bearing blocks for bearing the grinding roller, wherein the bearing
15 blocks are horizontally slidable and are guided in the machine frame rotatably about a vertical bearing axis intersecting the axis of rotation,
- c) a pressing device supported on the machine frame in order to apply an adjustable grinding pressure to the grinding roller via the bearing blocks, and
- 20 d) wherein at least two resilient compensation elements are associated with each bearing block in order to compensate a skewed position and/or deflection of the grinding roller, wherein the compensation elements – in the plan view of the roll crushing mill – are arranged tangentially to a circle around the vertical bearing axis and between
25 the machine frame and the bearing blocks.

According to a second embodiment of the invention, the roller mill for comminuting brittle grinding stock essentially consists of

- 5 a) at least one grinding roller rotatable about an axis of rotation, which interacts with a counter-surface in such a manner that the grinding stock is comminuted between grinding roller and counter-surface, wherein at least one grinding roller is constructed as a loose roller,
- 10 b) bearing blocks for bearing the grinding roller, wherein the bearing blocks are horizontally slidable and are guided in the machine frame rotatably about a vertical bearing axis intersecting the axis of rotation,
- 15 c) a pressing device supported on the machine frame in order to apply an adjustable grinding pressure to the grinding roller via the bearing blocks, and
- 20 d) wherein at least one resilient compensation element is associated with each bearing block in order to compensate a skewed position and/or deflection of the grinding roller, wherein the at least one compensation element – in the plan view of the roll crushing mill – is constructed in a circular arc around the vertical bearing axis and is arranged between the machine frame and the bearing blocks.

25 The tangential arrangement of at least two resilient compensation elements per bearing block or the circular arc construction of the compensation element enables the loads on the compensation element and the adjoining components during a rotary movement of the bearing blocks to be considerably reduced, whereby a greater operational reliability of the compensation elements and of the non-self-aligning bearings is achieved.

30 Further embodiments of the invention form the subject matter of the subsidiary claims.

The roller mill according to the invention covers in particular mills having a fixed or rotating counter-surface, wherein the counter-surface is formed, for example, by a rotating grinding table. A preferred embodiment of the invention, however, concerns a roll crushing mill, in which the counter-surface is formed by a

grinding roller in the form of a fixed roller, wherein the grinding stock is comminuted between the two oppositely driven grinding rollers.

Each bearing block may furthermore have a longitudinal median plane, which
5 contains the vertical bearing axis and is aligned perpendicularly to the grinding roller, i.e. perpendicularly to the axis of rotation of the grinding roller. The circular arc-shaped compensation element is then oriented preferably symmetrically with respect to this longitudinal median plane. In the case of a plurality of compensation elements per bearing block, these are likewise
10 arranged symmetrically with respect to this longitudinal median plane.

Furthermore, it is possible for the at least two compensation elements per bearing block to be of straight construction in plan view. In addition, the resilient compensation element can be arranged between the pressing device
15 and bearing block.

According to a preferred exemplary embodiment of the invention, the resilient compensation elements are formed from laminate materials, which, for example, can consist of elastomer layers reinforced with sheet steel. The
20 compensation elements advantageously have a modulus of elasticity of at least 100 N/mm^2 , preferably of at least 250 N/mm^2 . The shear modulus of the compensation elements should be at most 10 N/mm^2 , preferably at most 3 N/mm^2 .

25 With these properties, the resilient compensation elements are distinguished by a high compressive strength and high yield to impact. This results in especially low restoring torques when the bearing blocks are skewed. In combination with the tangential arrangement or circular arc-shaped construction of the compensation elements this makes a positive contribution to a long service life
30 of the compensation elements and the non-self-aligning bearings.

Further advantages and embodiments of the invention are explained in detail hereafter by means of the description and the drawings, in which:

- 5 Fig. 1 shows a plan view of a roller mill according to the invention,
- Fig. 2 shows a lateral view of the roller mill according to Fig. 1,
- 10 Fig. 3 shows a detail view of a compensation element according to a first exemplary embodiment,
- Fig. 4 shows a detail view of a compensation element according to a second exemplary embodiment,
- 15 Fig. 5 shows a detail view of a compensation element according to a third exemplary embodiment, and
- Fig. 6 shows a detail view of the compensation element according to Fig. 5 in a rotated position of the bearing block.
- 20 The exemplary embodiment according to Figures 1 and 2 shows a roller mill in the form of a roll crushing mill having a grinding roller 1 in the form of a loose roller and a grinding roller 2 in the form of a fixed roller, which are mounted so as to rotate with their grinding axes 1b and 2b, respectively, about axes of rotation 1a and 2a, respectively, in bearing blocks 3, 4 and 5, 6, respectively.
- 25 For that purpose, suitable bearings 11, such as, for example, cylindrical roller bearings, tapered roller bearings or sliding bearings, are mounted in the bearing blocks.
- The bearing blocks 3 to 6 are horizontally slidable and are rotatably guided in a machine frame 8 about vertical bearing axes 3a, 4a, 5a and 6a, respectively, intersecting the axes of rotation 1a and 2a.
- 30

Furthermore, a pressing device 10 supported on the machine frame 9 is provided, in order to apply an adjustable grinding pressure to the grinding rollers via the bearing blocks 5, 6. In addition, at least one resilient compensation element 12 for compensating a skewed position and/or deflection of the grinding rollers is arranged between each of the bearing blocks 3 and 4 and the machine frame 9 and between the pressing device 10 and each of the bearing blocks 5 and 6. As shown in Fig. 1, the compensation elements 12 are arranged – in the plan view of the grinding roll mill – tangentially to a circle about the associated vertical bearing axis 3a to 6a, as illustrated in detail hereafter by means of Figures 3 to 5.

In operation, the grinding rollers 1 and 2 are pressed against each other by the pressing device 10 with a high pressure of, for example, 50 MPa, and are driven in opposite directions by means of drive systems 7 and 8. The grinding stock to be comminuted is drawn into the adjustable nip 12 forming between the two grinding rollers 1 and 2 and is crushed. During operation, skewed positions or deflections of the grinding axes 1b and 2b may occur, and these skewed positions are transferred to the rotatably mounted bearing blocks 3 to 6. In order to ensure that force is transferred reliably between machine frame 9 or pressing device 10 and the bearing blocks, even when the bearing blocks are skewed, the compensation elements 12 are provided.

The compensation elements 12 are explained in detail hereafter using the example of the bearing block 5. The remarks can be applied correspondingly also to the other bearing blocks 3, 4 and 6.

In the first exemplary embodiment illustrated in Fig. 3, two straight compensation elements 12a, 12b are provided at the bearing block 5, which are arranged tangentially with respect to a circle K around the vertical bearing axis 5a. Furthermore, the two compensation elements 12a, 12b are oriented symmetrically with respect to the longitudinal median plane 5b, said longitudinal

median plane 5b containing the vertical bearing axis 5a and being aligned perpendicularly to the axis of rotation 2a.

5 Within the scope of the invention, it is also possible, however, for more than two such compensation elements to be provided. In the exemplary embodiment according to Fig. 5, three such compensation elements 12c to 12e are shown, which in turn are arranged tangentially with respect to the circle K around the vertical bearing axis 5a and symmetrically with respect to the longitudinal median plane 5b.

10

Whereas the compensation elements in the examples according to Figures 3 and 5 are straight, in the exemplary embodiment according to Fig. 4 a compensation element 12f of circular arc-shaped construction is used, which is arranged on the circle K about the vertical bearing axis 5a. Alternatively, of course, two, three or more circular arc-shaped compensation elements can be provided.

The compensation elements 12a to 12f consist, for example, of laminate materials, such as, for example, elastomer layers reinforced with sheet steel.

20

During the trials on which the invention is based, it proved especially advantageous for the resilient compensation elements to have a modulus of elasticity of at least 100 N/mm^2 , preferably of at least 250 N/mm^2 , and a shear modulus of at most 10 N/mm^2 , preferably at most 3 N/mm^2 .

25

Such compensation elements are distinguished by low restoring torques during radial deflection and by a high compressive strength.

Fig. 6 shows the situation during a skewed position of the bearing block 5. Because of the tangential arrangement, the bearing block is able to rotate about its vertical bearing axis 5a without tilting or a heavily one-sided loading of the compensation elements 12c, 12d and 12e occurring.

30

The tangential arrangement or circular arc-shaped construction of the compensation elements causes predominantly a stress based on thrust when the bearing blocks rotate. This thrust stress can be accommodated by elastomers without great reaction forces. It is thus possible to minimise the
5 reaction forces on the non-self-aligning cylindrical roller bearings, tapered roller bearings or sliding bearings. The roller bearings then have lower edge loads and an increased service life and the sliding bearing can be constructed to be more reliable in operation.

WHAT IS CLAIMED IS:

1. A roller mill for comminuting brittle grinding stock, having
 - a) at least one grinding roller rotatable about an axis of rotation, which interacts with a counter-surface in such a manner that the grinding stock is comminuted between grinding roller and counter-surface, wherein at least one grinding roller is constructed as a loose roller,
 - b) bearing blocks for bearing the grinding roller, wherein the bearing blocks are horizontally slidable and are guided in the machine frame rotatably about a vertical bearing axis intersecting the axis of rotation,
 - c) a pressing device supported on the machine frame in order to apply an adjustable grinding pressure to the grinding roller via the bearing blocks, and
 - d) wherein at least two resilient compensation elements are associated with each bearing block in order to compensate a skewed position and/or deflection of the grinding roller, wherein the compensation elements – in the plan view of the roll crushing mill – are arranged tangentially to a circle around the vertical bearing axis and between the machine frame and the bearing blocks.

2. A roller mill for comminuting brittle grinding stock, having
 - a) at least one grinding roller rotatable about an axis of rotation, which interacts with a counter-surface in such a manner that the grinding stock is comminuted between grinding roller and counter-surface, wherein at least one grinding roller is constructed as a loose roller,
 - b) bearing blocks for bearing the grinding roller, wherein the bearing blocks are horizontally slidable and are guided in the machine frame rotatably about a vertical bearing axis intersecting the axis of rotation,
 - c) a pressing device supported on the machine frame in order to apply an adjustable grinding pressure to the grinding roller via the bearing blocks, and

- d) wherein at least one resilient compensation element is associated with each bearing block in order to compensate a skewed position and/or deflection of the grinding roller, wherein the at least one compensation element – in the plan view of the roll crushing mill – is constructed in a circular arc around the vertical bearing axis and is arranged between the machine frame and the bearing blocks.
3. A roller mill according to claim 1 or 2, wherein the counter-surface is formed by a grinding roller in the form of a fixed roller, wherein the grinding stock is comminuted between the two oppositely driven grinding rollers.
 4. A roller mill according to claim 1 or 2, wherein each bearing block has a longitudinal median plane, which contains the vertical bearing axis and is aligned perpendicularly to the axis of rotation and the at least one resilient compensation element is oriented symmetrically with respect to said longitudinal median plane.
 5. A roller mill according to claim 1, wherein the compensation elements are of straight construction in plan view.
 6. A roller mill according to claim 1 or 2, wherein the resilient compensation elements are arranged between the pressing device and bearing block.
 7. A roller mill according to claim 1 or 2, wherein the resilient compensation elements are formed from laminate materials.
 8. A roller mill according to claim 1 or 2, wherein the resilient compensation elements consist of elastomer layers reinforced with sheet steel.
 9. A roller mill according to claim 1 or 2, wherein the resilient compensation elements have a modulus of elasticity of at least 100 N/mm².

10. A roller mill according to claim 1 or 2, wherein the resilient compensation elements have a shear modulus of at most 10 N/mm^2 .

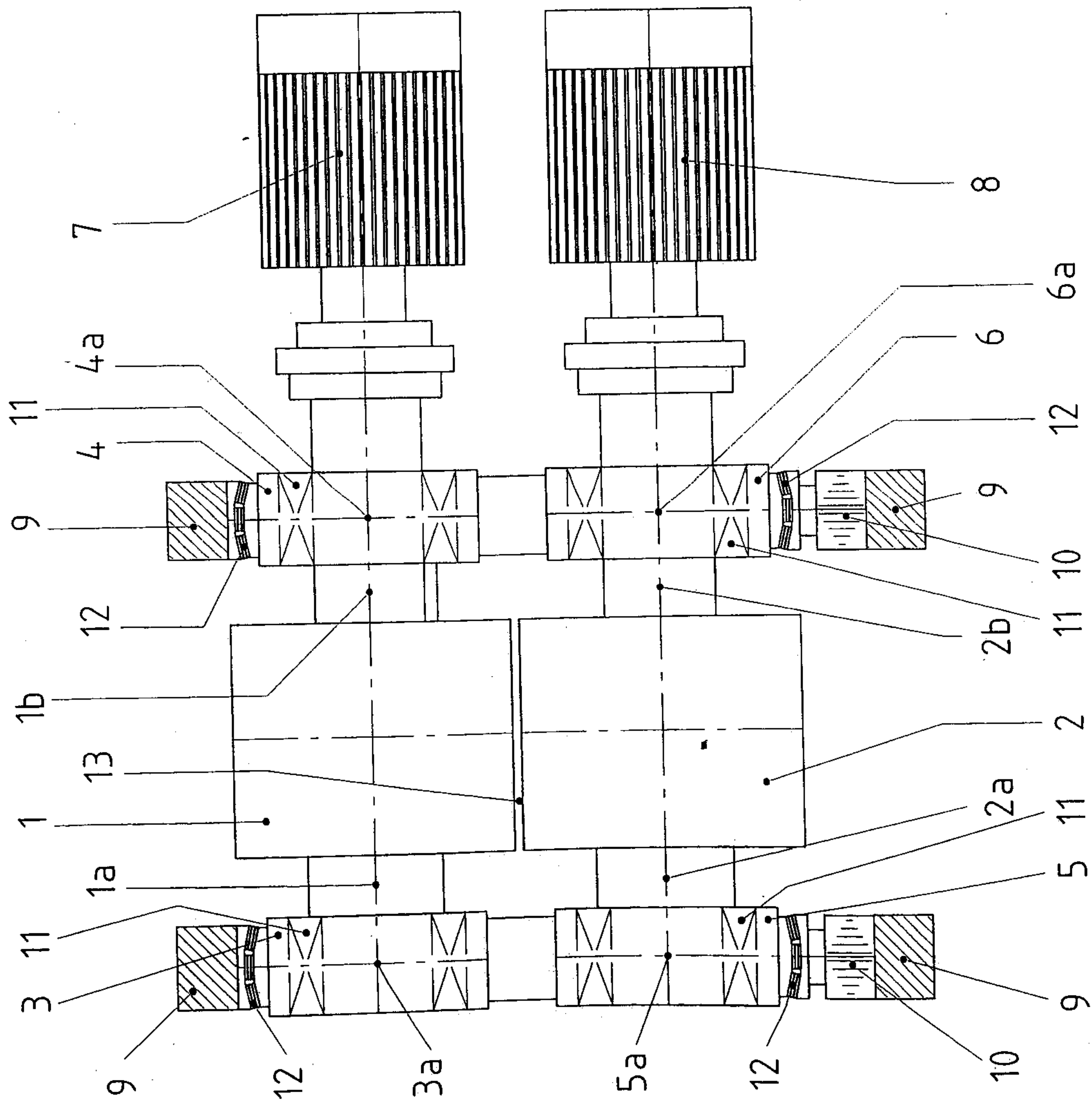

Fig.1

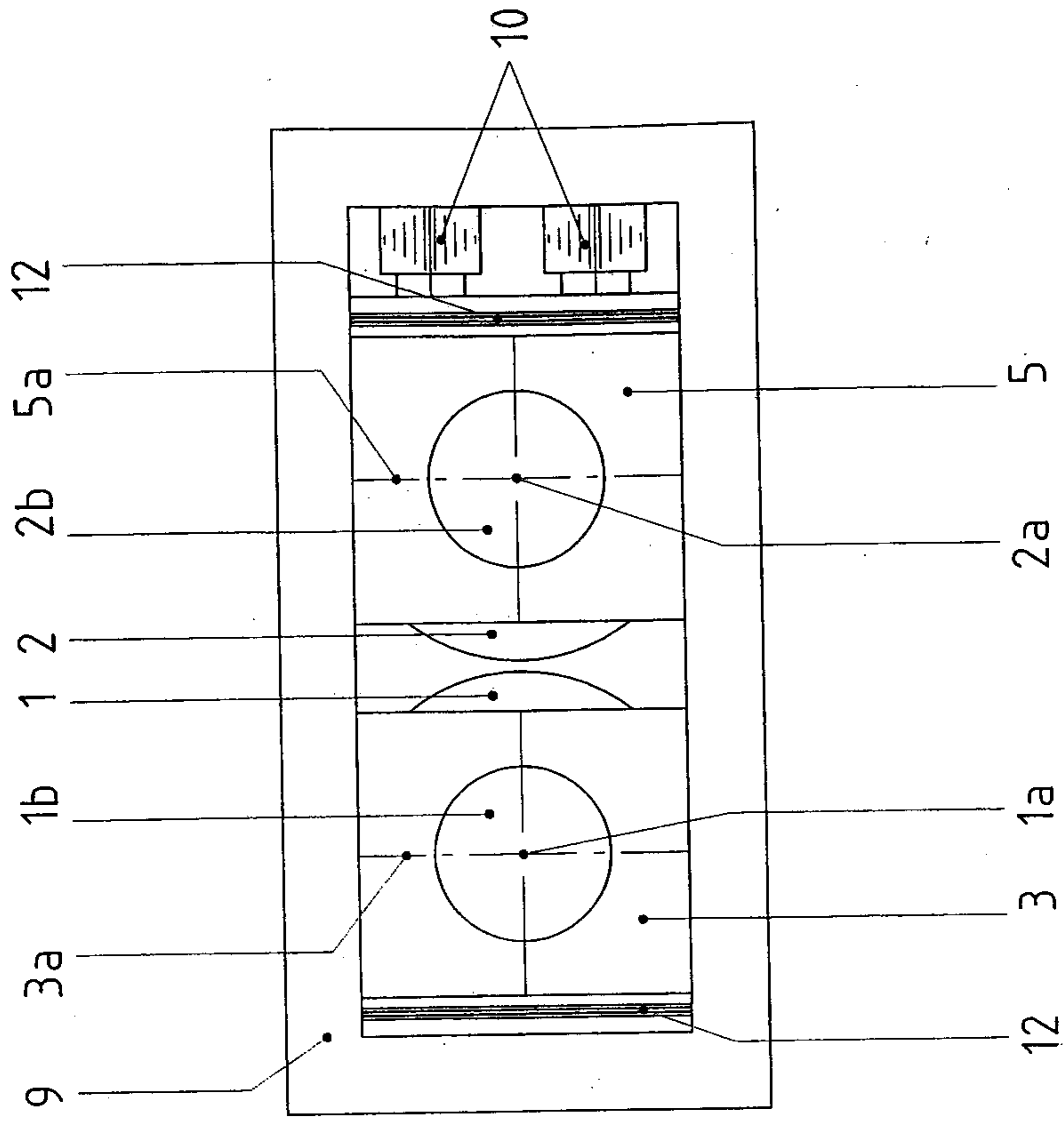

Fig.2

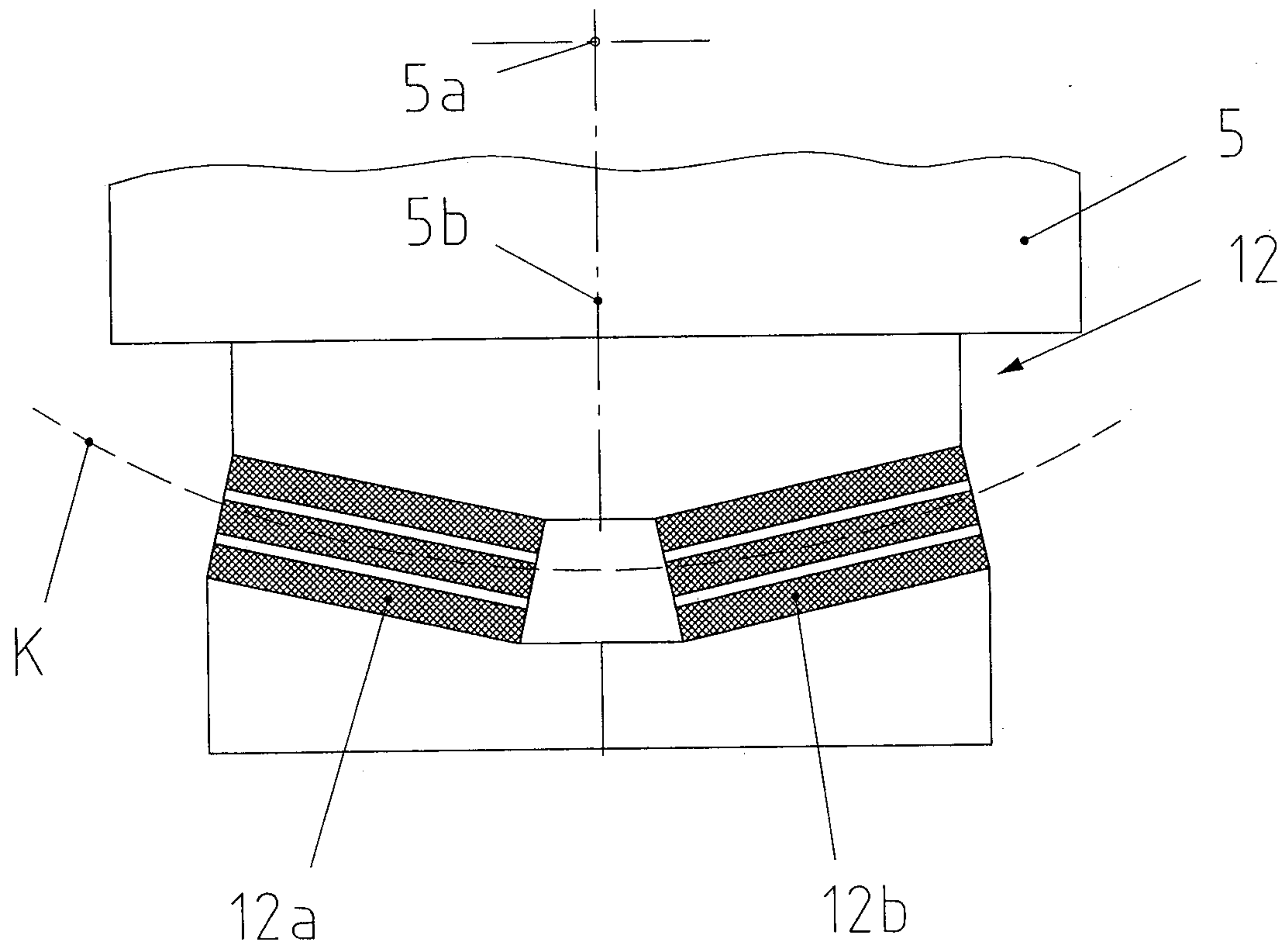

Fig. 3

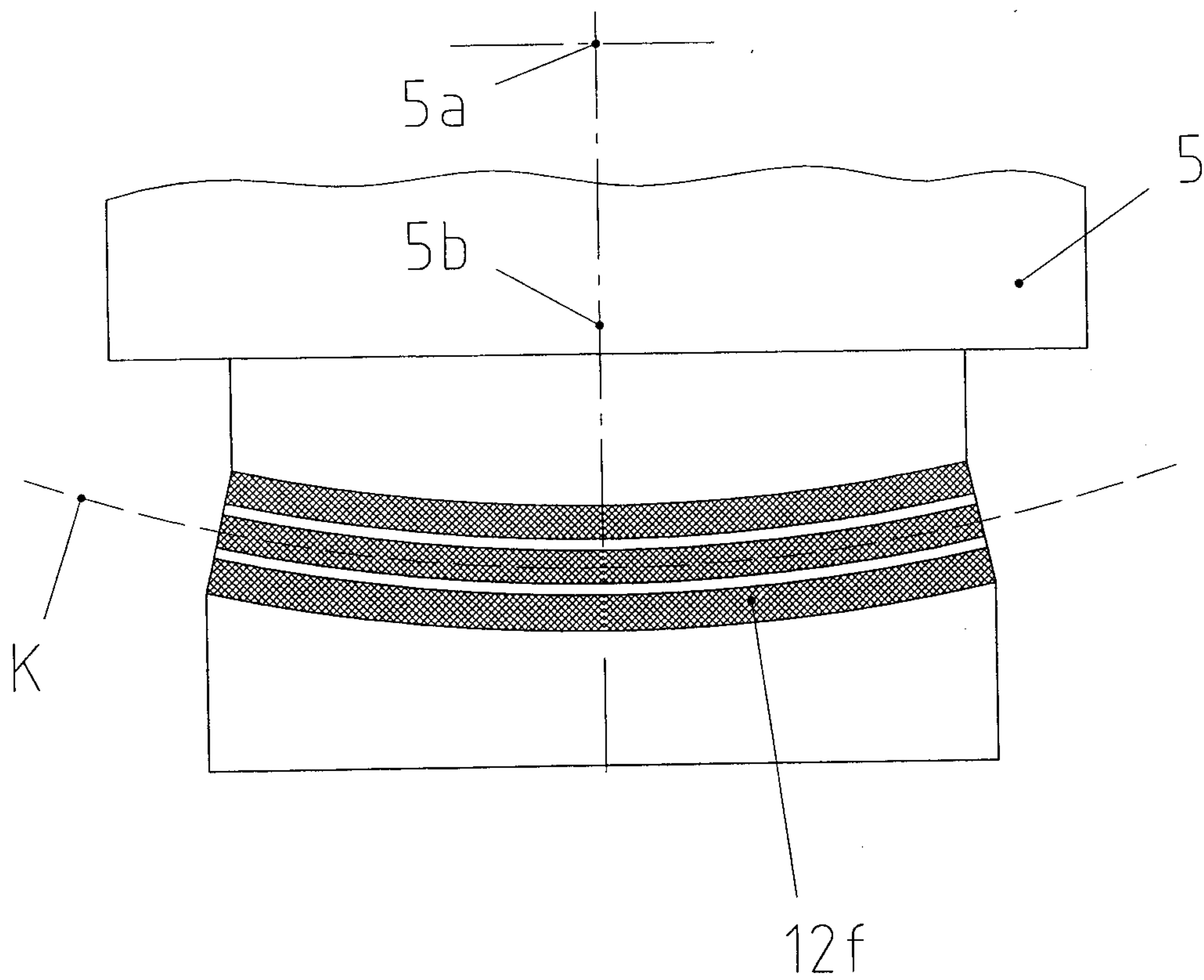

Fig. 4

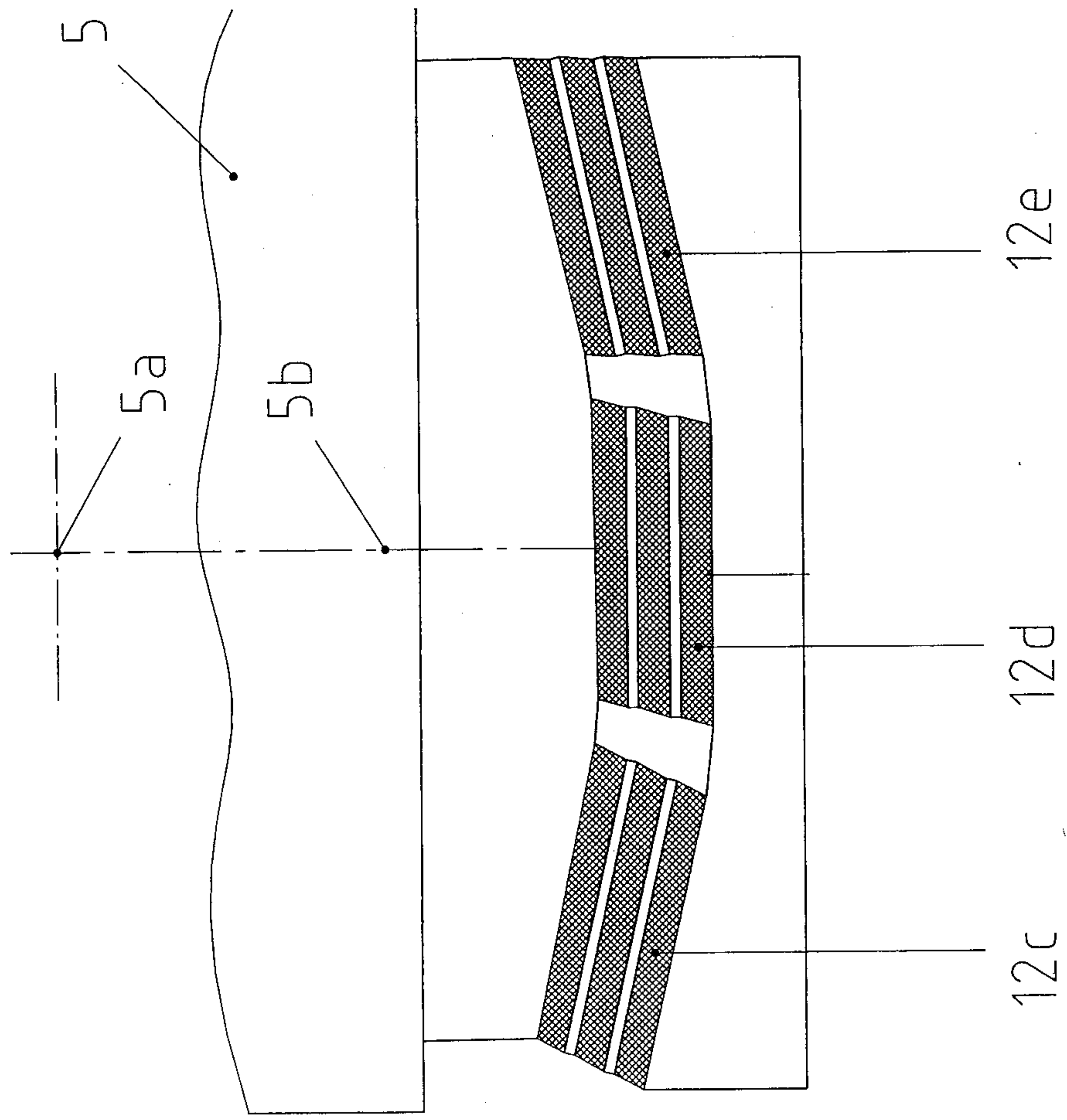

Fig.5

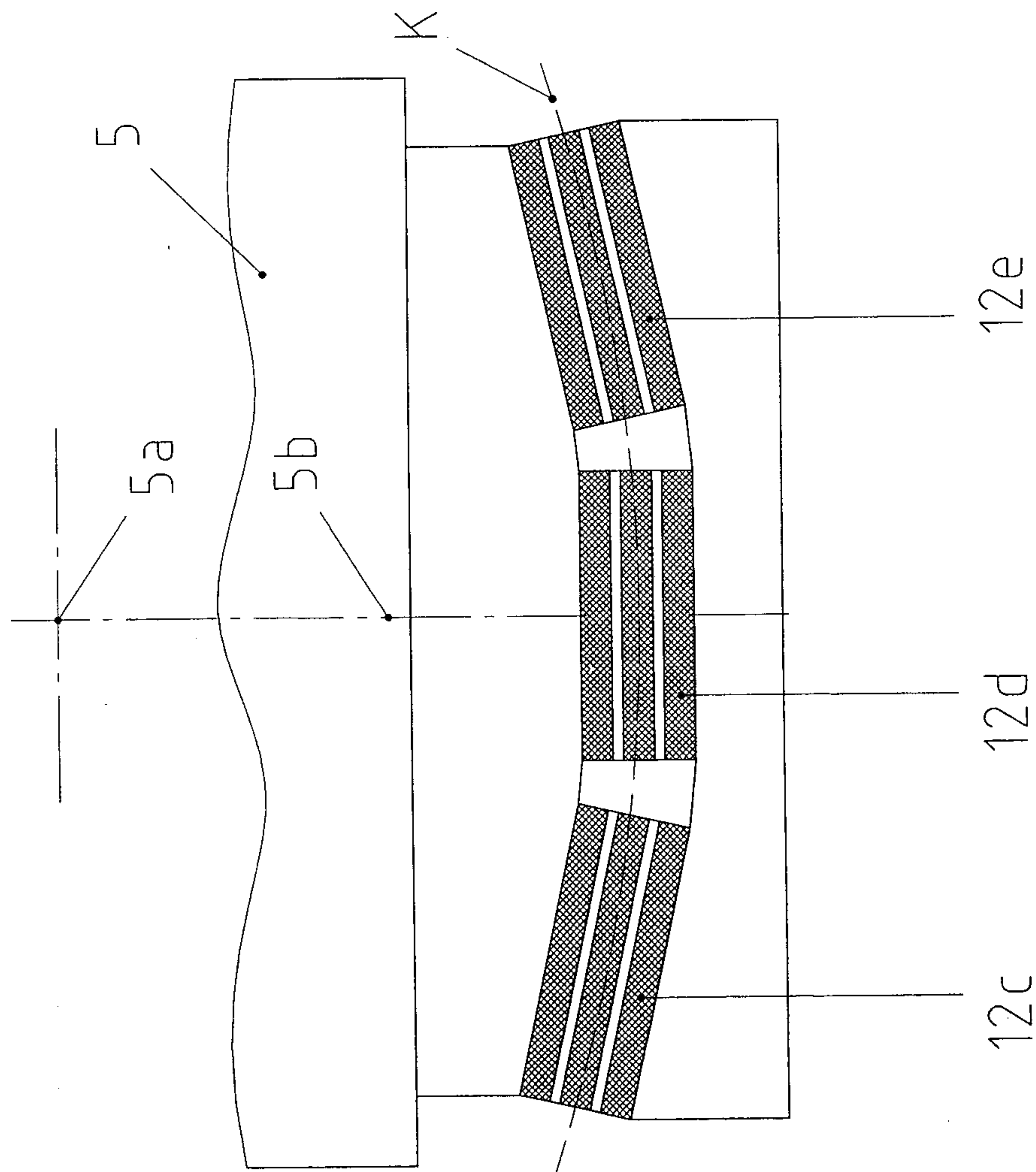

Fig.6

