

(12) UK Patent Application (19) GB (11) 2 308 829 (13) A

(43) Date of A Publication 09.07.1997

(21) Application No 9600007.0	(51) INT CL <sup>6</sup> B44F 1/00 1/10
(22) Date of Filing 02.01.1996	(52) UK CL (Edition O ) B6X XBX X10 X11 X13 B6G GNB G102 G104 G142 U1S S1714 S1727
(71) Applicant(s) S.D. Co., Ltd.  (Incorporated in Japan)  504-1 Onaricho 3-chome, Omiya-shi, Saitama, Japan	(56) Documents Cited GB 2165292 A JP 050057863 A JP 030001998 A
(72) Inventor(s) Kazumune Kenju	(58) Field of Search UK CL (Edition O ) B6G GLB GMB GMD GNB , B6X XBB XBX , E1R RPP RPX RS INT CL <sup>6</sup> A47F 11/06 11/08 , B41M 3/12 , B44C 1/00 1/16 3/00 , B44F 1/00 1/02 1/04 1/06 1/10 3/00 , G09F 7/00 19/12 19/14 ONLINE:WPI,CLAIMS
(74) Agent and/or Address for Service Marks & Clerk 57-60 Lincoln's Inn Fields, LONDON, WC2A 3LS, United Kingdom	

(54) Decorating see-through materials

(57) Decorated see-through material comprises on one surface a first pattern adapted to be viewed from the side of the surface of the see-through material and a second pattern adapted to be viewed from the side of the other surface of the see-through material, the first and second patterns being disposed in overlapping relationship. In a preferred method tapes (4) are detachably applied side by side to one of the surfaces of the see-through material (3), every second one of the tapes (4) are peeled off, a picture adapted to be viewed from the side of the other surface of the see-through material is drawn on the peeled-off portions, the peeled-off portions are then pigmented with for example silver or gray to form a coloured layer (7), another picture (8) adapted to be viewed from the side of the one surface is drawn on the layer (7) and the remaining tapes (4) are finally peeled off.

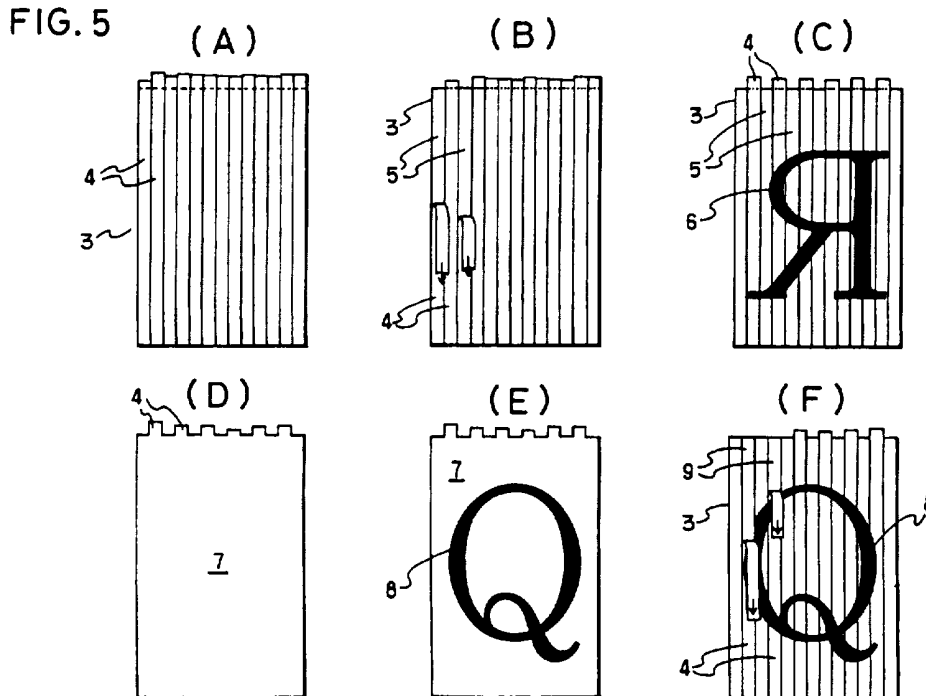

GB 2 308 829 A

FIG. 1A

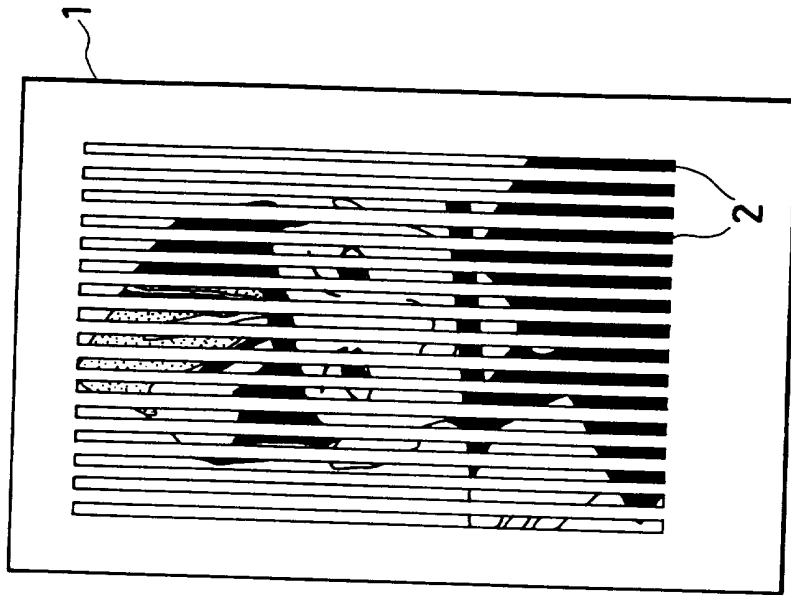

FIG. 1B

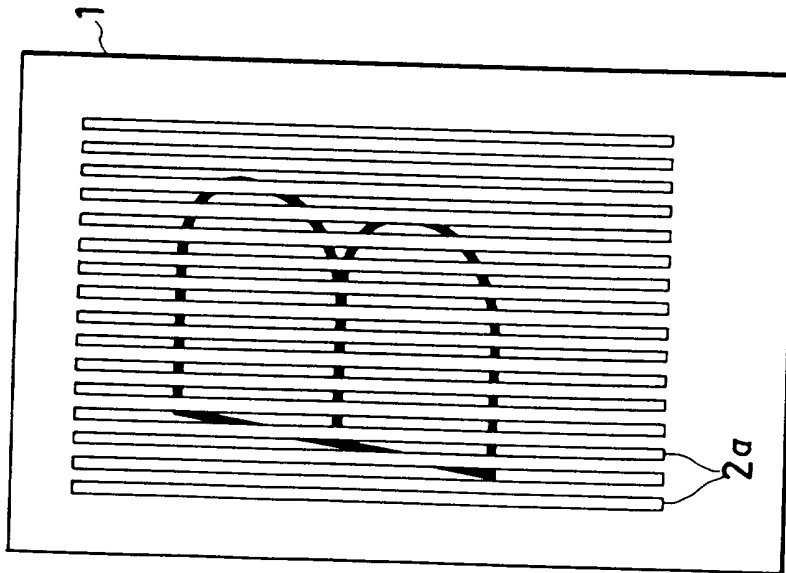

FIG. 2

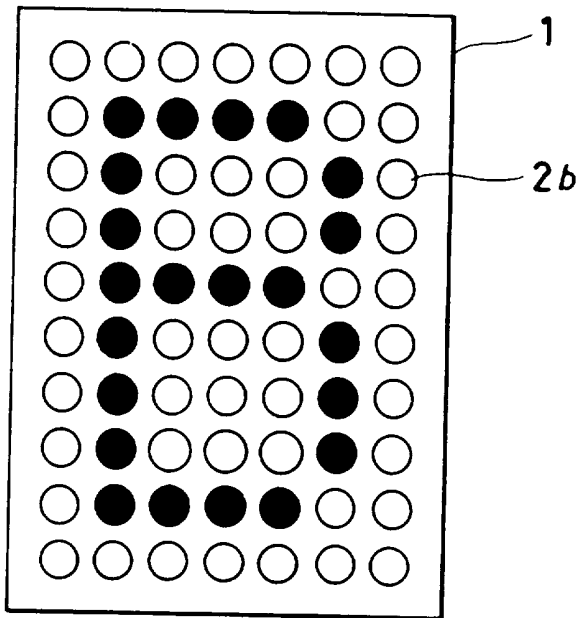

FIG. 3

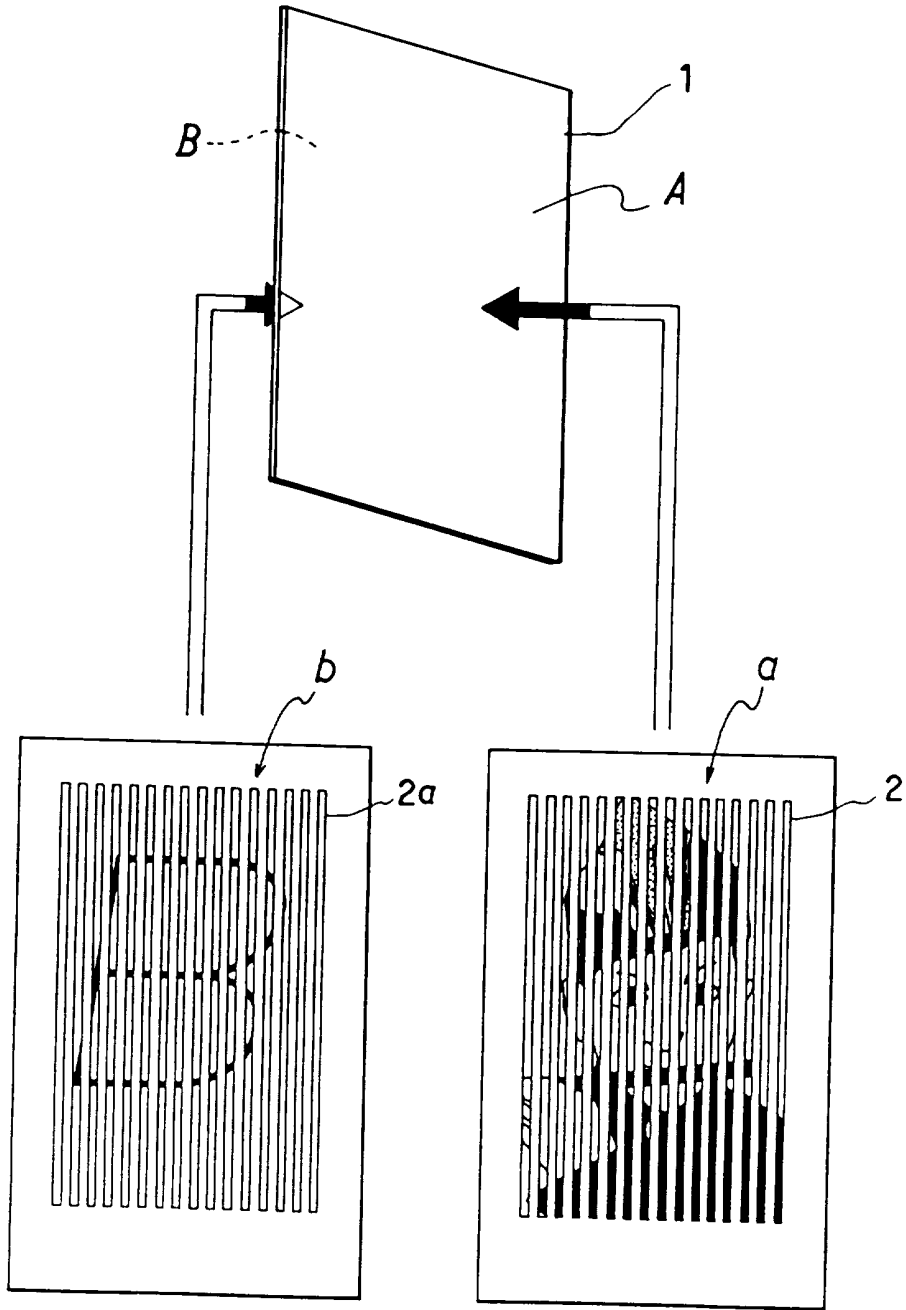

FIG. 4

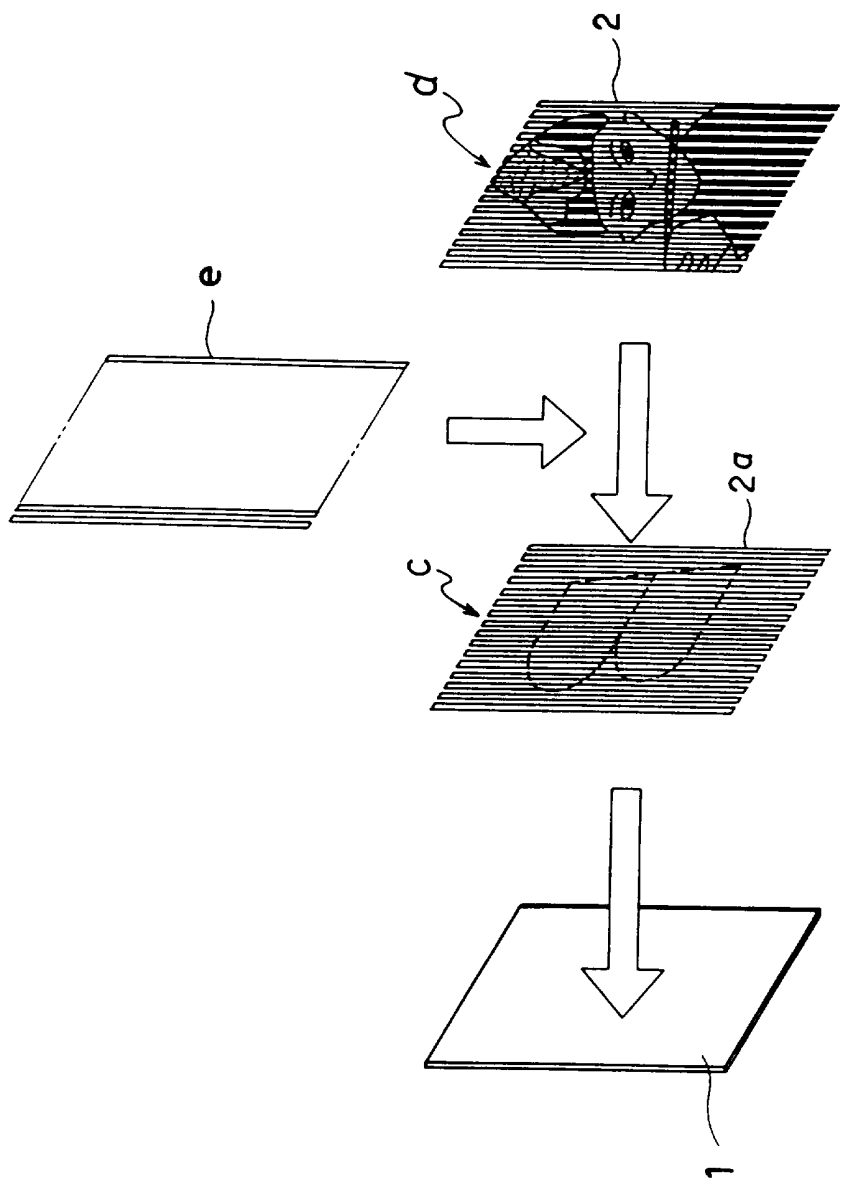

FIG. 5

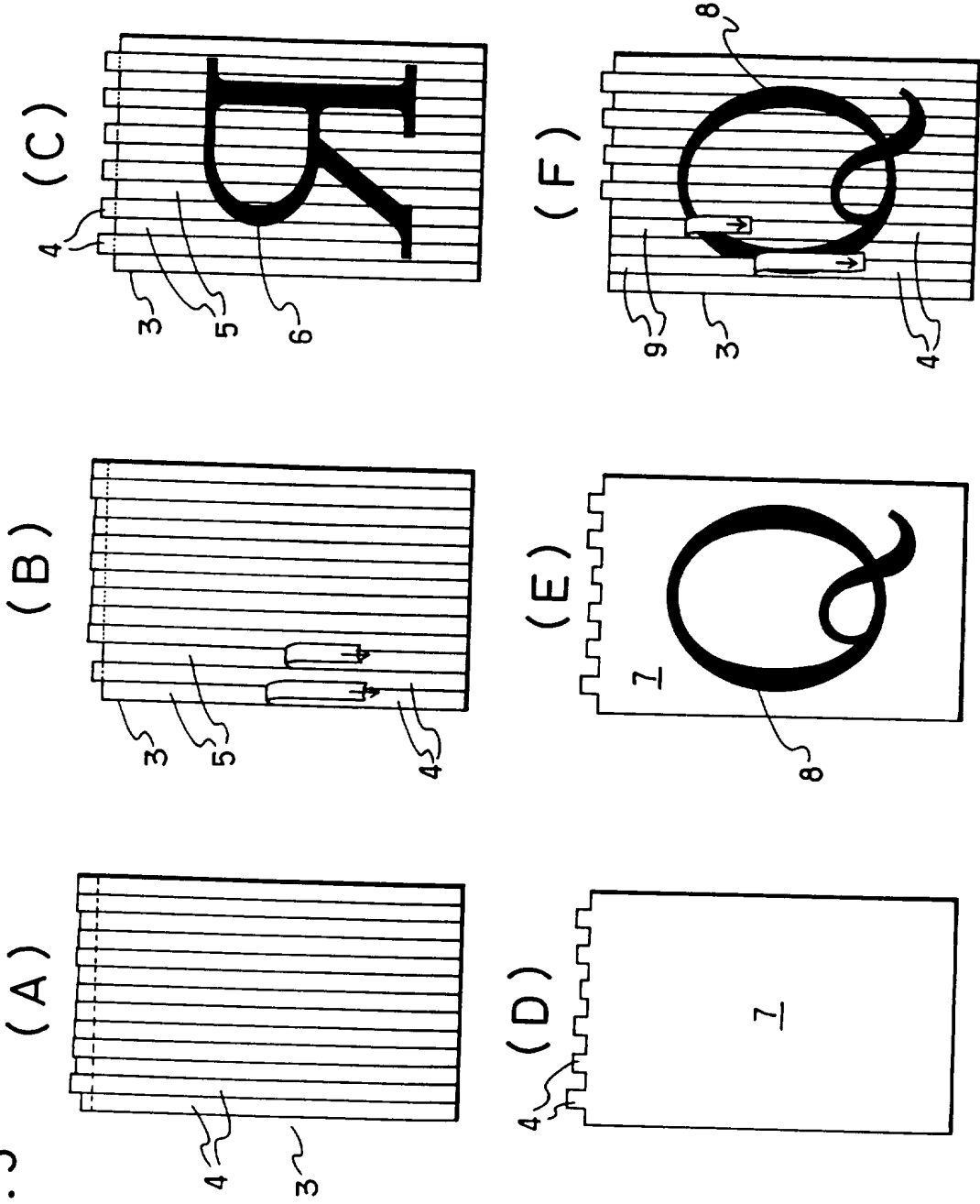
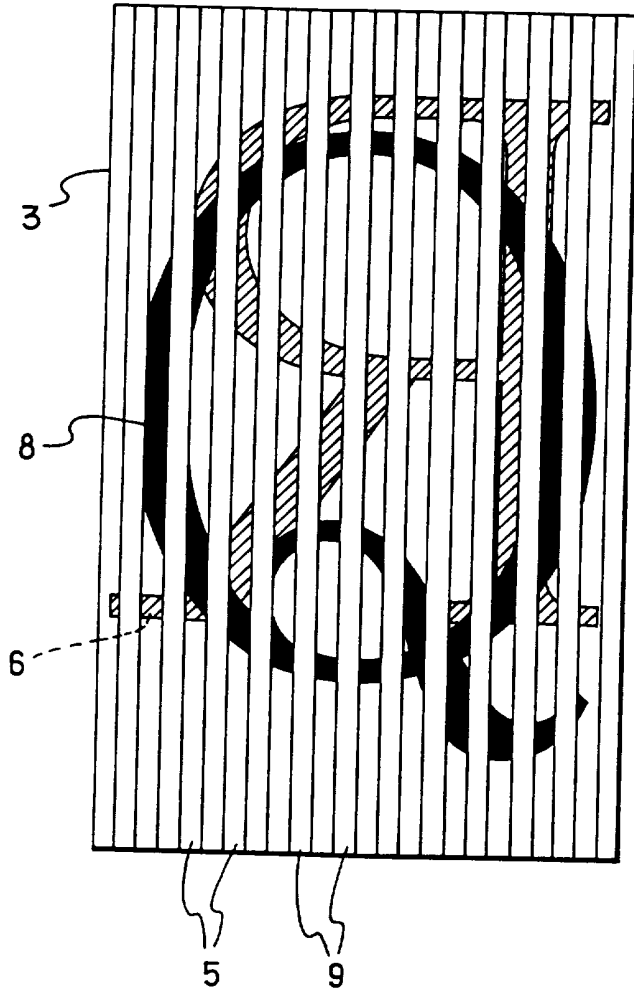

FIG. 6



METHOD FOR DECORATING  
SEE-THROUGH MATERIALS

The present invention relates to a method for decorating a see-through material, and more particularly to a method for decorating a see-through, i. e., semitransparent or transparent material such as glass, plastics, films and the like.

There are many see-through materials such as glass and the like for various decorative purposes, the materials being used in interior and exterior of not only shops such as beauty parlors, dressmaking shops, restaurants and like shops but also general family houses. Of these see-through materials, some ones are decorated with various modes of patterns, pictures, figures, characters and the like.

However, a conventional method for decorating the see-through materials is disadvantageous in that a product of such see-through decorated by using the



conventional decorating method must be viewed in a predetermined direction. In other words, the product is unattractive when viewed in the remaining directions. This restricts the product of the conventional decorating method within narrow limits in application.

Further, when the see-through material is used in the interior of a room and decorated with a certain type of patterns, the room is often impaired in clearness and in roominess, and, therefore fails to make the best use of the properties of the see-through material.

Under such circumstances, the present invention was made. Consequently, it is an object of the present invention to provide a method for decorating a see-through material with a novel mode, the method making the best use of transparency properties of the see-through material without impairing the interior of a room in clearness and in roominess when used therein, and having the thus decorated see-through material be attractive even when viewed from the rear of the see-through material, which enlarges in application the sphere of the see-through material and also increases in usefulness the see-through material.

According to a first aspect of the present invention, the above object of the present invention is accomplished by providing:

A method for decorating a see-through material, characterized in that:

one of opposite surfaces of the see-through material is provided with a line- or a dot-pattern portion representing a picture adapted to be viewed

from the side of the one surface of the see-through material; and

another line- or another dot-pattern portion representing another picture adapted to be viewed from the side of the other surface of the see-through material is disposed in completely overlapping relation in configuration with the line- or the dot-pattern portion of the one surface of the see-through material.

According to a second aspect of the present invention, the above object of the present invention is accomplished by providing:

A method for decorating a see-through material comprising the steps of:

detachably applying a plurality of tapes side by side to one of opposite surfaces of the see-through material such as glass, plastics, films and the like to be decorated, the tapes thus applied side by side extending in an arbitrary direction, i.e., extending vertically, horizontally or obliquely without overlapping with each other and without providing any gap therebetween;

peeling off every second one of the applied tapes to form a plurality of peeled-off portions in the one surface of the see-through material;

drawing a picture on the peeled-off portions of the one surface of the see-through material, the picture being adapted to be viewed from the side of the other of the opposite surfaces of the see-through material;

entirely pigmenting the peeled-off portions of the one surface of the see-through material with silver, gray and the like to form a colored layer thereon;

further drawing another picture on the colored

layer, the another picture being adapted to be viewed from the side of the one surface of the see-through material; and

peeling off the remaining tapes thus applied to the one surface of the see-through material therefrom.

In the see-through material thus decorated according to the method of the present invention, the pictures may be so drawn as to be viewed from the side of any of opposite surfaces of the see-through material. In the thus decorated see-through material, since one of the pictures, which is drawn on one of the opposite surfaces of the see-through material, can not be viewed from the side of the other of the opposite surfaces of the see-through material (or, the other of the pictures can not be viewed from the side of the one of the opposite surfaces of the see-through material), it is possible to separately decorate the opposite surfaces of the see-through material with different types of pictures. Since the pictures are drawn on a plurality of the peeled-off portions (i. e., line- or dot-pattern portions) of the see-through material, it is possible for the see-through material to partially keep its transparency, which makes the thus decorated see-through material attractive in appearance.

#### BRIEF DESCRIPTION OF THE DRAWINGS

Fig. 1A is a front view of see-through material decorated with a picture according to the method of the present invention;

Fig. 1B is a rear view of see-through material decorated with another picture according to the method of the present invention;

Fig. 2 is a front view of see-through material decorated with further another picture

according to the method of the present invention;

Fig. 3 is a view illustrating an embodiment of the method of the present invention;

Fig. 4 is a view illustrating another embodiment of the method of the present invention;

Figs. 5A to 5F are views illustrating a series of steps of further another embodiment of the method of the present invention; and

Fig. 6 is a front view of the see-through material produced according to the embodiment of the method of the present invention shown in Figs. 5A to 5B.

#### DESCRIPTION OF THE PREFERRED EMBODIMENTS

Hereinbelow, the present invention will be described in detail with reference to the accompanying drawings.

As shown in Figs. 1A and 1B, a see-through material 1 is a semitransparent or a transparent material such as glass and like materials, and decorated with pictures according to an embodiment of a method of the present invention for decorating the see-through material. The see-through material 1 thus decorated is provided with a plurality of line-pattern portions 2 and 2a in its front surface A (shown in Fig. 3) and its rear surface B (shown in Fig. 3), respectively. The line-pattern portions 2, 2a, each of which has a predetermined width, are spaced apart from each other at predetermined intervals. When the line-pattern portions 2, 2a are excessively widely spaced apart from each other, it is difficult to recognize the pictures drawn on the line-pattern portions 2, 2a. On the other hand, when the line-pattern portions 2, 2a are too narrowly spaced apart from each other, the see-through material thus decorated becomes poor in transparency. Consequently, it is necessary to

determine the intervals of the line-pattern portions 2, 2a with reference to the width of each of the line-pattern portions 2, 2a. The line-pattern portions 2, 2a may be constructed of horizontally-extending straight portions, obliquely-extending straight or curved portions, or waved portions and the like in addition to the vertically-extending straight portions as shown in the drawings. Further, the line-pattern portions 2, 2a may be replaced with dot-pattern portions 2b as shown in Fig. 2. Such dot-pattern portions 2b may be of any types of configurations. Fig. 1A shows one of opposite surfaces (i. e., front surface A) of the see-through material 1 provided with the line-pattern portions 2 on which a picture (denoted by the reference character "a" shown in Fig. 3) of a boy playing on a flute is drawn. In other words, the picture "a" is constructed of a plurality of see-through portions and the line-pattern portions 2 of the see-through material 1. Since the line-pattern portions 2 are spaced alternately with the see-through portions at appropriate intervals, it is possible to recognize the picture "a" on the line-pattern portions 2 as one of the boy playing on the flute.

Fig. 1B shows the other of opposite surfaces (i. e., rear surface B shown in Fig. 3) of the see-through material 1 provided with the line-pattern portions 2a on which another picture (i. e., character "B" denoted by the reference character "b" shown in Fig. 3) is drawn. The line-pattern portions 2a in the rear surface B of the see-through material 1 are disposed in completely overlapping relation in configuration with the line-pattern portions 2 of the front surface A of the see-through material 1. Consequently, it is possible to view each of the

pictures from the side of each of the opposite surfaces of the see-through material 1. As is clear from the above, the method of the present invention for decorating the see-through material may bring about the interesting effect that: it is impossible to view the character "B" from the side of the front surface A of the see-through material 1, while it is also impossible to view the picture of the boy from the side of the rear surface B of the see-through material 1.

In the present invention, the see-through material 1 may be decorated with any types of pictures, characters, figures, patterns, marks, photographs and the like (hereinafter generally referred to as the picture). It is also possible to decorate the opposite surfaces of the see-through material with the same picture.

Incidentally, the line-pattern portions 2, 2a and the dot-pattern portions 2b may be printed on a single piece of transparent film and the like, provided that they are separated in appearance.

The picture drawn on the see-through material 1 may be produced by using a single-printing method (shown in Fig. 3) on each of the opposite surfaces of the see-through material 1 or a double-printing method (shown in Fig. 4) on one of the opposite surfaces of the see-through material 1.

As shown in Fig. 3, in the former (i.e., the single-printing method on each of the opposite surfaces of the see-through material 1), essentially, a thin see-through material 1 such as films and the like is used. In this method, first, the line-pattern portions 2 representing a desired picture "a" are provided in the front surface A of the see-through material 1, the picture "a" being adapted to be viewed

from the side of the front surface A. The picture "a" may be directly printed or drawn on the front surface A of the see-through material 1, or applied or transferred to the front surface A through an adhesive film. It is also possible to use any other suitable printing processes for providing the picture "a" in the front surface A of the see-through material 1. Then, the line-pattern portions 2a representing another picture "b" are disposed in the rear surface B of the see-through material 1 in completely overlapping relation in configuration with the line-pattern portions 2 of the front surface A of the see-through material 1, the picture "b" being adapted to be viewed from the side of the rear surface B. Incidentally, in order to prevent each of the pictures "a", "b" from being transparent, each of these pictures is preferably backed with a colored layer "e" (shown in Fig. 4). The colored layer "e" is pigmented with silver which reflects light, black which absorbs light, gray and like colors.

Now, the double-printing method (shown in Fig. 4) on one of the opposite surfaces of the see-through material 1 will be described in detail. In the double-printing method, first, the line-pattern portions 2a representing a picture "c", which is adapted to be viewed through the see-through material 1 from the side of the other of the opposite surfaces of the see-through material 1, are provided in the one of the opposite surfaces of the see-through material 1. Then, the line-pattern portions 2, which represent another picture "d" adapted to be directly viewed from the side of the one of the opposite surfaces of the see-through material 1 and completely overlap with the line-pattern portions 2a in configuration, are provided in the one of the opposite surfaces of the

see-through material 1. In this case, as described above, the picture "c" is viewed through the see-through material 1, while the picture "d" overlapping with the picture "c" is directly viewed. In this double-printing method, preferably, each of the pictures "c", "d" is carried on a peelable paper through which each of the pictures "c", "d" is applied on the see-through material 1. Further, it is preferable to interpose the colored layer "e" between the line-pattern portions 2 and 2a, the colored layer "e" completely covering the line-pattern portions 2a and is preferably pigmented with silver, black, gray and the like so as to prevent the pictures "c", "d" from being transparent.

Figs. 5A, 5B, 5C, 5D, 5E and 5F show further another method for decorating the see-through material 1 with pictures, the method comprising the following steps.

(1) A peelable tape application step shown in Fig. 5A:

A plurality of peelable tapes 4 are applied side by side to one of opposite surfaces of the see-through material 3 such as glass, plastics, films and like materials being decorated, without overlapping with each other and without providing any gap therebetween. The one of the opposite surfaces of the see-through material 3 is hereinafter referred to a front surface A. The entire front surface A of the see-through material 3 is not necessarily covered with the tapes 4. The thus applied tapes 4 may extend in any desired direction, i. e., extend horizontally, obliquely, or vertically as is in the case shown in Fig. 5A;

(2) A first tape-peeling step shown in Fig. 5B:

Every second one of the tapes 4 thus



detachably or peelably applied to the front surface A of the see-through material 3 is peeled off to form a plurality of see-through portions 5 which are formed into opaque portions later). These see-through portions 5 are spaced alternately with the tapes 4 on the front surface A of the see-through material 3;

(3) A first picture drawing step shown in Fig. 5C:

A picture 6 such as the character "R", which is adapted to be viewed from the other (i. e., a rear surface B) of the opposite surfaces of the see-through material 3 as shown in Fig. 5C, is drawn on the front surface A of the see-through material 3. As a result, parts of the character "R" can be viewed from the rear surface B of the see-through material 3 through the see-through portions 5;

(4) A colored layer application step shown in Fig. 5D:

The picture 6 drawn on the front surface A of the see-through material 3 is completely covered with a colored layer 7, which is pigmented with silver, black, gray, white and the like, so that the see-through portions 5 are formed into opaque portions 5;

(5) A second picture drawing step shown in Fig. 5E:

Another picture 8, such as the character "Q", which is adapted to be viewed from the one (i. e., front surface A) of the opposite surfaces of the see-through material 3 as shown in Fig. 5E, is drawn on the colored layer 7. The character "Q" may be replaced with the character "R" so that this picture 8 is the same as that picture 6; and

(6) A second tape-peeling step shown in Fig. 5F:

The remaining tapes 4 applied on the front surface A of the see-through material 3 are peeled off from the see-through material 3, so that parts of each of the picture 6, colored layer 7 and the picture 8

applied to the remaining tapes 4 are also removed from the see-through material 3, whereby see-through portions 9 are formed on the front surface A of the see-through material 3 as shown in Fig. 5F and 6. As a result, the remaining parts of the picture 8 such as the character "Q" drawn on the colored layer 7 can be directly viewed from the side of the front surface A of the see-through material 3, while the remaining parts of the picture 6 such as the character "R" can be viewed from the side of the rear surface B of the see-through material 3 there the same 3.

Fig. 6 shows the see-through material 3 thus prepared according to the double-printing method described above. As is clear from Fig. 6, the picture 8 such as the character "Q" can be viewed from the side of the front surface A of the see-through material 3 except its parts corresponding to the see-through portions 9 on the front surface A. On the other hand, the picture 6 such as the character "R" can be viewed from the side of the rear surface B of the see-through material 3 except its parts corresponding to the see-through portions 9 on the rear surface B. Incidentally, in fact, the character "R" represented by the shaped area in Fig. 6 can not be viewed from the side of the front surface A of the see-through material 3. The shaped area are provided in Fig. 6 for convenience of description of the double-printing method. The see-through portions 9 provided in the see-through material 3 thus decorated with the pictures 6, 8 permit a user to view the other side of the see-through material 3 therethrough.

As described above, the present invention enables the see-through material to utilize its properties at maximum in decoration of the interior or the exterior of the building, which enlarges in

application the sphere of the see-through material prepared according to the method of the present invention, and also increases in usefulness the see-through material.

**Claims:**

1. A method for decorating a see-through material, characterized in that:

one of opposite surfaces of said see-through material is provided with a line- or a dot-pattern portion representing a picture adapted to be viewed from the side of said one surface of said see-through material; and

another line- or another dot-pattern portion representing another picture adapted to be viewed from the side of the other surface of said see-through material is disposed in completely overlapping relation in configuration with said line- or said dot-pattern portion of said one surface of said see-through material.

2. The method for decorating the see-through material as set forth in claim 1, wherein:

said another line- or said another dot-pattern portion, which completely overlaps with said line- or said dot-pattern portion of said one surface of said see-through material in configuration, is disposed in the other surface of said see-through material after said line- or said dot-pattern portion of said one surface of said see-through material is disposed in said one surface of said see-through material.

3. The method for decorating the see-through material as set forth in claim 1, wherein:

said another line- or said another dot-pattern portion, which is adapted to be viewed from the side of the other surface of said see-through material, is disposed in said one surface of said see-through material so as to be viewed from the side of the other surface of said see-through material; and, then

said line- or said dot-pattern portion of said one surface of said see-through material, which

completely overlaps with said another line- or said another dot-pattern portion in configuration, is disposed in said one surface of said see-through material so as to be viewed from the side of said one surface of said see-through material.

4. The method for decorating the see-through material as set forth in any one of claims 1, 2 and 3 wherein:

a colored layer is interposed between said line- or said dot-pattern portions of each of said opposite surfaces of said see-through material, said colored layer being pigmented with silver, black, gray and the like.

5. A method for decorating a see-through material comprising the steps of:

detachably applying a plurality of tapes side by side to one of opposite surfaces of said see-through material such as glass, plastics, films and the like to be decorated, said tapes thus applied side by side extending in an arbitrary direction, i. e., extending vertically, horizontally or obliquely without overlapping with each other and without providing any gap therebetween;

peeling off every second one of said applied tapes to form a plurality of peeled-off portions in said one surface of said see-through material;

drawing a picture on said peeled-off portions of said one surface of said see-through material, said picture being adapted to be viewed from the side of the other of said opposite surfaces of said see-through material;

entirely pigmenting said peeled-off portions of said one surface of said see-through material with silver, gray and the like to form a colored layer thereon;

further drawing another picture on said colored layer, said another picture being adapted to be viewed from the side of said one surface of said see-through material; and

peeling off the remaining tapes thus applied to said one surface of said see-through material therefrom.

6. A method for decorating a see-through material, substantially as described with reference to Figure 3, Figure 4, or Figures 5A to 6 of the accompanying drawings.

7. A see-through material decorated by a method according to any preceding claim.

**Application No:** GB 9600007.0  
**Claims searched:** 1 to 7

**Examiner:** R.J.MIRAMS  
**Date of search:** 16 April 1996

**Patents Act 1977**  
**Search Report under Section 17**

**Databases searched:**

<p>UK Patent Office collections, including GB, EP, WO &amp; US patent specifications, in:</p> <p>UK Cl (Ed.O): B6G(GLB, GMB, GMD, GNB); B6X (XBB, XBX); E1R (RPP, RPX, RS)</p> <p>Int Cl (Ed.6): A47F 11/06, 11/08, B41M 3/12; B44C 1/00, 1/16, 3/00; B44F 1/00, 1/02, 1/04, 1/06, 1/10, 3/00; G09F 7/00, 19/12, 19/14.</p> <p>Other: ONLINE: WPI, CLAIMS.</p>
--

**Documents considered to be relevant:**

Category	Identity of document and relevant passage	Relevant to claims
X	GB2165292A (Campbell) e.g. figures 4 and 26(5) and page 14 lines 65 to 75	1,3 and 4
X	JP050057863A (Dainippon) see abstract	at least 1
X	JP030001998A (Toppan) see abstract	at least 1

X	Document indicating lack of novelty or inventive step	A	Document indicating technological background and/or state of the art.
Y	Document indicating lack of inventive step if combined with one or more other documents of same category.	P	Document published on or after the declared priority date but before the filing date of this invention.
&	Member of the same patent family	E	Patent document published on or after, but with priority date earlier than, the filing date of this application.