

(19)  
(12)

(KR)  
(Y1)

(51) 。 Int. Cl.<sup>7</sup>  
A01G 9/22

(45)  
(11)  
(24)

2004 05 13  
20-0350456  
2004 05 04

(21) 20-2004-0002425  
(22) 2004 02 02

(73) 292 101-1706

(72) 292 101-1706

460 102-901

(74)

:

(54)

( )

,

,

(P)

0)가 (1) 가 (2) (C) (1,2)가 (C) (3)가 (10) , (3)가 (20) (32) (34) (2)

가 가 가 가 (10) (10) (20) (20) (P) (1,2)

가 가 (42) (12,22)가 (40) (41)가

1 ,  
 2 1 ,  
 3 1 ,  
 4 2 ,  
 5 ,  
 6 1 ,  
 7 6 ,  
 8 9 ,  
 10 ,  
 11 10 ( ) ,  
 12 11 ,  
 13 ( ) ,  
 14 13 ,  
 15 13 ,  
 16 15 .

\*

1,2 : 3 :  
 10 : 11 :  
 11a : 12 :  
 12a : 13 :  
 13a : 14 :  
 15 : 16 :  
 17 : 20,20' :  
 21 : 21a :  
 22 : 22a :  
 23 : 23a :  
 24 : 25 :  
 26 : 26a :

27 : 27a :

28 : 29 :

32 : 34 :

40 : 41 :

42 : C : ( )

C' : ( ) C" : ( )

P :

, ( )

263497 , 230310 , 230311 , 246171 , 252378 , 252379 , 254023

252378 , 252379 , 254023 , 230310 , 230311

가 , ,

, 246171 ,

가 가 , 가

, 263497 가 ( ) 가

282267 ) 1 ( )

2002-8224 ( 가 가

, 가 가 , 가 2 , 가



(10) (1,2)가 (1,2)가

(1,2) (10) (16)가 (16) (10)

15 (16)

1 5 (3)가 (24)가 (3) (C) (20) (20)

(10) (20) (11,21)가 (12,22)가

(11,21) (12,22) (32) (13,23)

(12,22) (22a) (22a)가 (12a)

(11,21) (11a,21a)가

) (21) (10) (11) (32) (34) (13a) (20)가

(23a)

(P) (44) (1,2) 가 (C)

(40) (P) (46)가 282267 (1,2) (P)

(42)가

(P) (41) (41) (41)가

(40) (P) 가 (40) 가

(42) (46) (44)

(1,2) 8 9

(P) (P) (1,2) (1,2) (C) (3)

C) (3) (C) 1) (C) (2) (32)

(34) (20) (10)

(20) (2) (1) (3) (2) (C)

(1,2) (3) 1 가

1 가 (3) (1,2) (C) (3) (1,2)

(32)

( ) 가 가

10 (C) ( )

11 10 ( ) (C) (10) 가 1

5 (20) 가 (28)가 (3)

(29)

11 (29)

(C) (3)

12 11 (20)가 가

20')가 13 ( :C') (10) ( )

(3) (20') (20')

14 13 (C') (20')가 L

15 16 13 (C'') (20')

(10) (10) (20')가 (17) (25) (26)

(26a) (27a) (3) (27)

(27) (27a) (3) 1 (27) (27)

(3) (3) (3)

(3)

(3)

(27a) ( 25mm) 25mm  
 (27a)  
 ( 30mm) (27a)  
 (3) , 1 (27) (27) 1 (2  
 7a) 가 , (27) 1 (2  
 (27a) (3) .  
 (C") (3) 1 (27) ( )  
 27a) (3) .  
 가 가 가 가 가  
 가 가 가 가 가  
 가 가 가 가 가  
 가 가 가 가 가

(57)

1. (P) (1) (2) (C) (3)가  
 가 (C) (1,2)가 (10) (3)가 (20)가 (32) (34) 가  
 가 (10) (10) (20) (20) 가  
 (12,22)가 .
2. 1 (12,22)  
 (22a) (22a)가 (12a)
3. 1 2 ,  
 (P) (1,2) 가 (40) ,  
 (41)가 , (42)가 .
4. 3 ,  
 (41) .
5. 1 2 ,  
 (20) 가 ,  
 (28)가 .

6.

5

,

(20)

(29)

.

7.

(P)

(1)

(2)

(C)

(3)가

,

(C)  
(20')

(1,2)가  
(10)

(10)

(17)

(20')가 ,  
(25) ,

(26a)가

(26) ,  
1

(26)  
(27)

.

8.

7

,

(27a)

.



1

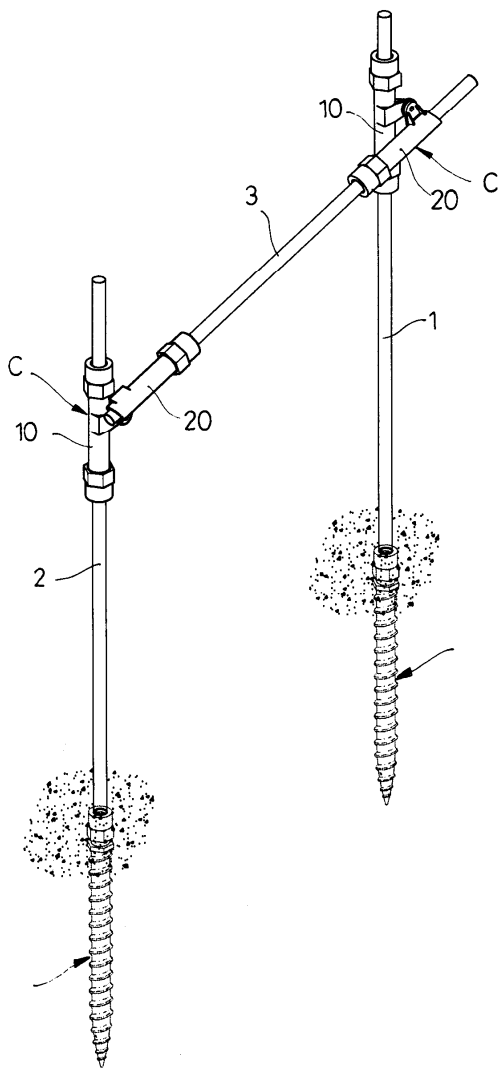

2

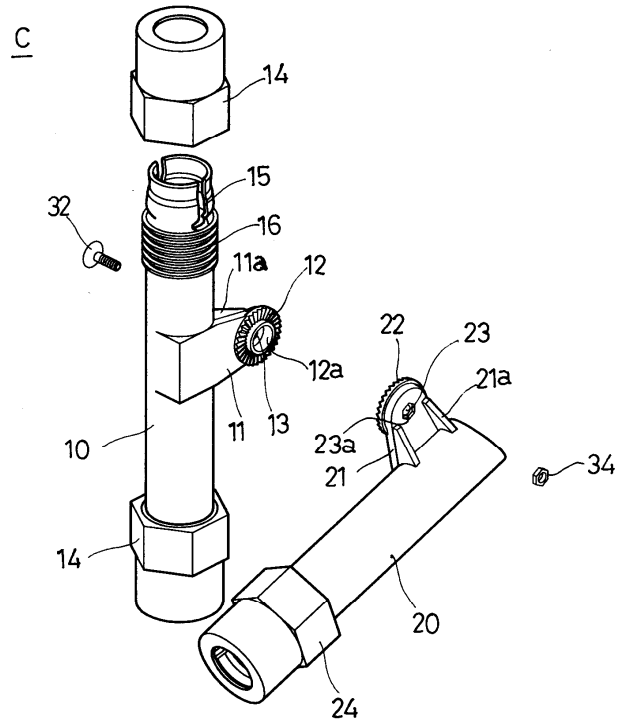

3

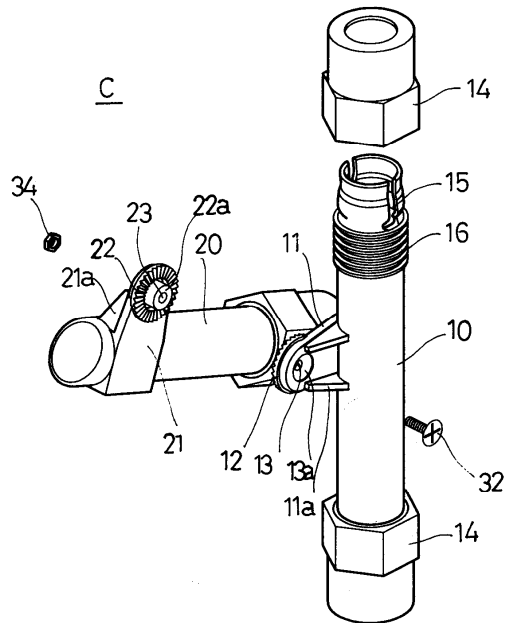

4

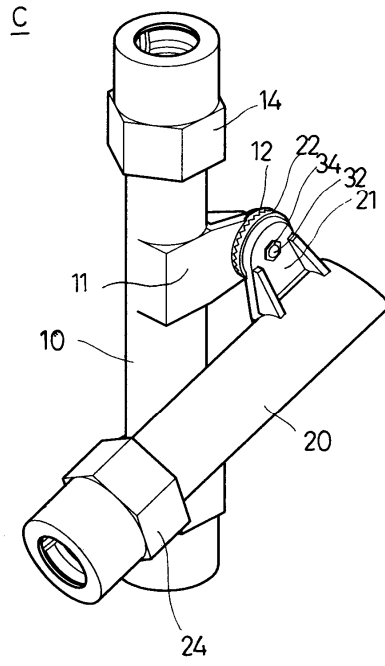

5

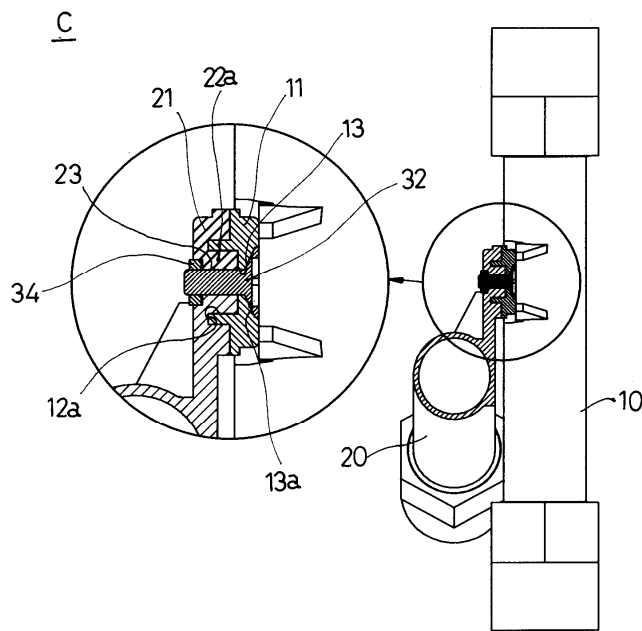

6

P

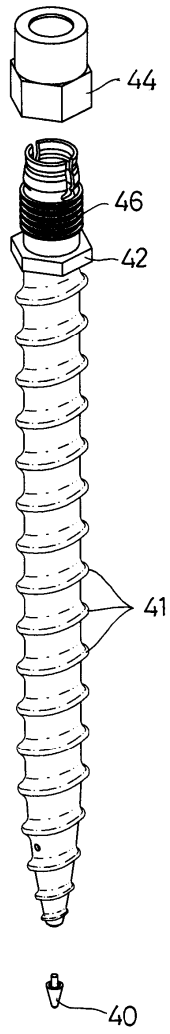

7

P

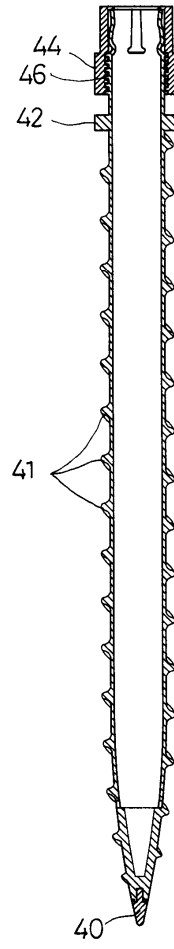

8

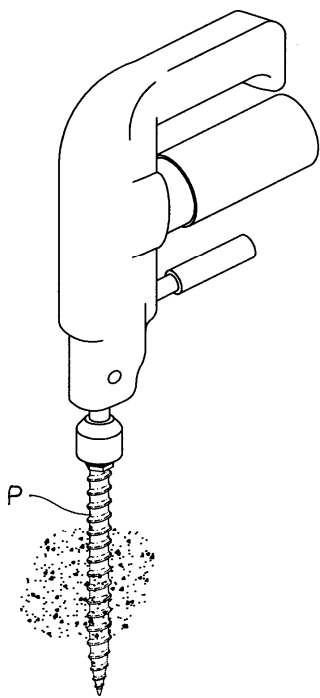

9

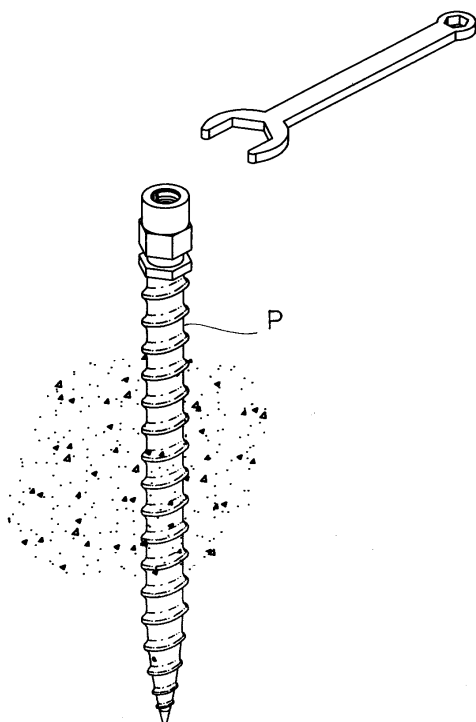

10

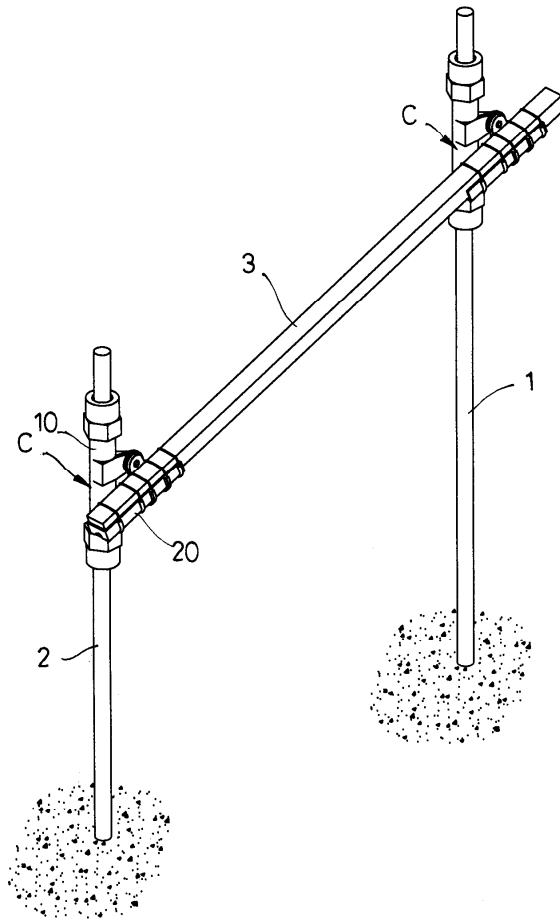

11

C

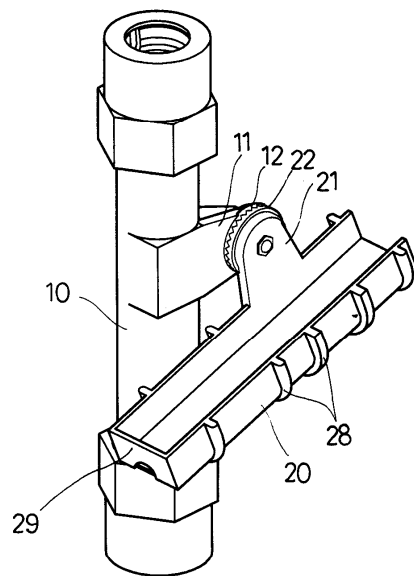

12

C

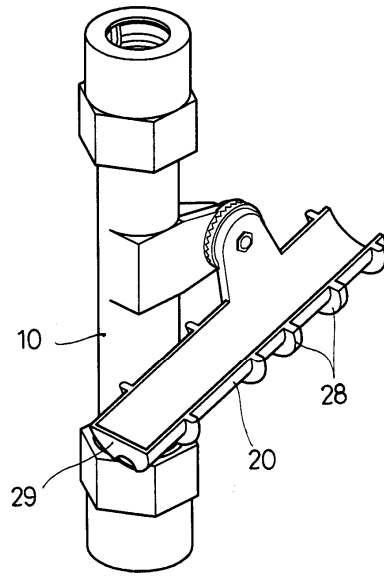

13

C'

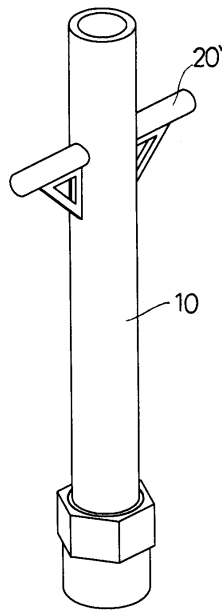



14

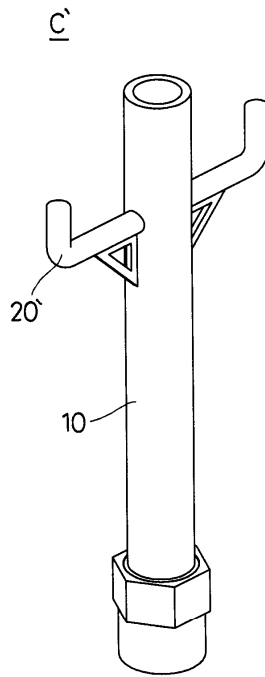

15

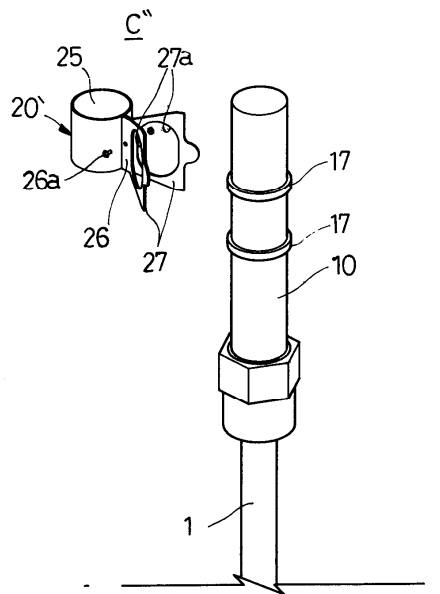

16

