

FOR THE PURPOSES OF INFORMATION ONLY

Codes used to identify States party to the PCT on the front pages of pamphlets publishing international applications under the PCT.

AT	Austria	ES	Spain	MG	Madagascar
AU	Australia	FI	Finland	ML	Mali
BB	Barbados	FR	France	MR	Mauritania
BE	Belgium	GA	Gabon	MW	Malawi
BF	Burkina Fasso	GB	United Kingdom	NL	Netherlands
BG	Bulgaria	HU	Hungary	NO	Norway
BJ	Benin	IT	Italy	RO	Romania
BR	Brazil	JP	Japan	SD	Sudan
CA	Canada	KP	Democratic People's Republic of Korea	SE	Sweden
CF	Central African Republic	KR	Republic of Korea	SN	Senegal
CG	Congo	LI	Liechtenstein	SU	Soviet Union
CH	Switzerland	LK	Sri Lanka	TD	Chad
CM	Cameroon	LU	Luxembourg	TG	Togo
DE	Germany, Federal Republic of	MC	Monaco	US	United States of America
DK	Denmark				

5

DILATATION CATHETER ASSEMBLY WITH CUTTING ELEMENTDescription

10

Technical Field

The present invention is in the field of surgical devices, particularly dilatation catheters. Specifically, it concerns a dilatation catheter whose expandable member carries a cutting element which concurrently incis-

15 member carries a cutting element which concurrently incis-
cises the tissue being subjected to dilatation forces, thereby reducing trauma and damage to such tissue from the dilatation forces.

20 Background

Dilatation catheters are used to dilate body vessels, orifices and conduits such as an artery narrowed by atherosclerotic plaque and/or fibromuscular disease or to dilate a constricted or obstructed ureter or urethra.

25 They basically consist of an elongated catheter having an inflatable balloon or bladder at or near its distal end. A guide wire or other axial support means is often included to improve the torque control or "steerability" of the apparatus.

30 The major advantage of dilatation catheter use over conventional surgery is that it is less invasive. Nonetheless, the tissue that is stressed is often also subjected to significant trauma. As the bladder expands, it exerts pressure on the surrounding tissue, causing the

35 tissue to compress, deform and expand. The tissue, of course, has an inherent limit of deformability. When the

dilatation pressure causes the tissue to deform beyond that limit, the tissue tears apart with considerable damage, trauma, pain, and bleeding. A principal object of the present invention is to provide a dilatation catheter that
5 permits tissue to be stressed, even beyond its limit of deformability, without experiencing uncontrolled tearing and the undesirable conditions associated therewith.

Disclosure of the Invention

10 The invention is a dilatation catheter assembly comprising in combination: an elongated tubular body having a distal end carrying a radially dilatable member adapted to dilate and exert pressure on surrounding body tissue; means for dilating the dilatable member and a cut-
15 ting element carried on the exterior of the dilatable member that moves radially in concert with the exterior of the dilatable member that is adapted to incise said tissue, thereby reducing damage to said tissue from dilatation forces.

20 In use the novel catheter of the invention concurrently exerts pressure on the tissue and makes a clean, sharp incision in the tissue while the tissue is subjected to the dilatation forces exerted by the dilating member. The incision allows the tissue to separate along a pre-
25 determined path and in a relatively clean, trauma-free manner as compared to the uncontrolled tearing that occurs when using prior devices.

Accordingly, another aspect of the invention is a method for dilating a body conduit, vessel or orifice
30 comprising: inserting therein a dilatation catheter assembly comprising an elongated tubular body having a distal end carrying a radially dilatable member adapted to dilate and exert pressure on surrounding body tissue and a cutting element carried on the exterior of the dilatable
35 member; dilating the dilatable member to an extent that causes the tissue to be simultaneously stressed by the

dilatable member and incised by the cutting member; radially contracting the dilatable member to cause the dilatable member and cutting element to disengage the tissue; and withdrawing the dilatation catheter assembly there-
5 from.

Brief Description of the Drawings

In the drawings, which are not to scale:

Figure 1 is a partly cross-sectional, isometric
10 view of one embodiment of the invention catheter.

Figure 2 is a cross-sectional view taken along
line 2-2 of Figure 1.

Figure 3 is a perspective, schematic sectional
view of a portion of another embodiment of the invention
15 catheter positioned within a body conduit.

Figure 4 is a sectional, side view of the embodi-
ment of Figure 3 in its deflated state.

Figure 5 is a sectional side view of the embodi-
ment of Figure 3 in its inflated state.

Figure 6 is a cross-sectional view along line 6-
20 6 of Figure 5.

Figure 7 is a sectional elevational view of
another embodiment of the invention.

In the drawings like parts are referred to by
25 the same reference numerals.

Detailed Description of the Invention

Figure 1 depicts a dilatation catheter assembly,
generally designated 10, that may be used for dilating a
30 body vessel or conduit, such as a ureter or urethra, to
treat a blockage or other obstruction. The main elements
of catheter assembly 10 are: an adapter 11 that defines
the proximal end 12 of the assembly and a site for various
ports to the assembly; a catheter body 13 having a triple
35 lumen 14 (Figure 2); an inflatable balloon or bladder
member 15; a stiffening stylet 16 that extends

longitudinally within one of the three lumens of the catheter body; and a cutting element 17. As seen in Figure 2, one of the three lumens 14 serves as an inflation/deflation passageway 18, a second carries stylet 16 and serves as a drainage/infusion passageway, and a third carries cutting element 17.

The adapter 12 serves as a site for a bladder inflation/deflation port 19 that is attached to a source of inflation medium (not shown) for inflating the bladder or a suction source (not shown) for deflating the bladder. Port 19 has a valve 20 for regulating the inflation medium or suction, as the case may be. Port 19 connects into the proximal end of an inflation/deflation passageway 18 that extends from the port 19 to the bladder. The adapter also serves as a site for the drainage tube inlet/outlet port 22 and a cutting element port 23. The drainage port is connected to the proximal end of the lumen that carries the stylet 16. The drainage port may serve as a site for removing fluid from the lumen or as a site for infusing fluid into the lumen. The distal end of the catheter body has a series of drain holes 24 to facilitate flushing the lumen with fluid or voiding the bladder. A "banana plug" cutting element connector 25 is affixed to the end of the cutting element port and the cutting element extends from the connector through the lumen of the catheter body and exits therefrom via an aperture 26 and continues along the exterior of the bladder. The cutting element consists of a thin wire which has an external incising edge that faces outwardly from the bladder. Alternatively, the cutting element may be a sharp edge, beam, or cauterizing element. The element/bladder is/are constructed (e.g., the element is flexible or expandable) such that the element is carried on the exterior of the bladder (at least when the bladder is inflated) but is not capable of incising the bladder. If desired, the portion of the exterior of the bladder that is exposed to the element may carry a protec-

tive cover (not shown) to further guard against the bladder being incised by the element. The element may be carried at a predetermined spacing from the bladder surface or directly on the surface. When carried on the surface
5 the element may be an integral part of the surface or attached to the surface. If desired the cutting element may be extended/retracted manually via the connector into/out of the catheter body.

For use in urethral dilatation the distal end of
10 the assembly includes a coudet tip 27. Such structure may not be necessary or desirable for dilating other conduits/orifices. For urethral dilation, the assembly may optionally include another lumen and "Foley" type balloon (not shown) distally of the dilatation bladder to anchor the
15 catheter in the bladder neck of the human body to facilitate correct positioning of the dilatation bladder and minimize the possibility of migration and displacement of the assembly.

One or more of the catheter assembly components
20 may be made of radioopaque materials to facilitate the visualization of the assembly by the physician during placement of the assembly in the body vessel/conduit.

The typical surgical procedure in which the catheter assembly 10 is employed involves the following
25 steps. Normally a cystoscope is first inserted into the vessel/conduit/orifice to be dilated. Calibration devices may be inserted through the cystoscope to facilitate measuring the extent of the vessel/conduit/orifice being dilated. The dilatation catheter of Figure 1 is then
30 inserted to the desired depth in the vessel/conduit. A cystoscope lens may then be inserted through the catheter body to allow visualization of the catheter and the bladder location. Fluid may be infused through the drainage tube or cystoscope to facilitate such visualiza-
35 tion. Once in position, the bladder is inflated. Such inflation causes the cutting element to move radially

outwardly as the bladder surface expands radially until the cutting element contacts the surrounding tissue. As used herein the term "tissue" is intended to include, without limitation, normal tissue, neoplastic tissue (tumors) or an obstruction such as plaque. Continued radial expansion of the bladder positions the cutting element and causes the bladder to exert pressure on the tissue. This combined cutting and dilating action results in the tissue being expanded without being torn due to a buildup of excess stresses within the tissue. Instead, the tissue is cut in a clean, concentrated fashion by the cutting element and the dilatation does not uncontrollably tear the tissue and cause excessive trauma and bleeding. The inflated bladder provides the additional benefit of acting as a tamponade to reduce bleeding.

After the vessel/conduit/orifice tissue is incised and dilated and the blockage/obstruction is relieved, the bladder is deflated by connecting the inflation/deflation port to suction or atmospheric pressure and opening the inflation/deflation port valve thereto. Deflation of the bladder results in a simultaneously radial retraction of the cutting element out of contact with the tissue. Once the bladder is deflated the cutting element may be retracted via the connector 25. If desired, the element may be retracted prior to complete deflation of the bladder and/or the bladder reinflated and left in place to act as a tampon. Alternatively, the catheter is withdrawn from the vessel/conduit altogether.

Figures 3-6 depict another dilatation catheter assembly of the invention, generally designated 29, in use. Only the distal end of the assembly is shown. Adapter(s), inflation/deflation ports are not shown for convenience. The distal end is defined by a closed end catheter tube 32 which carries an inflatable bladder member 33 on its exterior. The lumen 34 of tube 32 is connected to the source of inflation fluid/suction, as the

case may be. The tube has a radial aperture 35 that opens into the lumen 36 of the bladder member. A pair of expandable ring-shaped members 37, 38 extend around the exterior of the bladder member near the distal and proximal ends thereof. One or more cutting elements 39 are affixed between the rings so that they extend longitudinally and outwardly therefrom.

Figures 3 (in solid line) and 4 show the assembly in its deflated state positioned within a vessel partially obstructed by an obstruction 43. In order to inflate the bladder, pressurized fluid is passed through catheter tube lumen 34 and aperture 35 into the bladder lumen. Inflation of the bladder in turn causes the ring members 37, 38 to expand and move the cutting element(s) 39 radially outward. Figures 3 (phantom line), 5, and 6 show the bladder in an inflated state with the cutting element 39 incising the obstruction.

Figure 7 shows yet another dilatation catheter assembly, generally designated 46, of the invention. The assembly is shown in its deflated state. This assembly is similar in structure to assembly 29 except that the assembly is housed within a sheath or introducer 47 and a cauterizing element 48 is connected to the cutting element 39. The sheath permits the assembly to be introduced into the vessel in an unexposed manner, ejected from the end thereof for use, and retracted back into the sheath after use. The ejection and retraction may be achieved by relative longitudinal movement of the sheath, assembly, or both. The heating element permits the cutting element (which in this instance must be made of a heat conducting material) to be heated to a temperature which allows the tissue to be both incised and cauterized. The heating element is connected to a heat source/control, schematically shown at 49.

Modifications of the embodiments of the dilatation/incising catheter assembly described above that are

obvious to those of skill in the surgical instruments art are intended to be within the scope of the following claims.

5

10

15

20

25

30

35

Claims

1. A dilatation catheter assembly comprising in combination: an elongated tubular body having a distal end carrying a radially dilatable member adapted to dilate and exert pressure on surrounding body tissue, means for dilating the dilatable member, and a cutting element carried on the exterior of the dilatable member that moves radially in concert with the exterior of the dilatable member that is adapted to incise said tissue, thereby reducing damage to said tissue from dilatation forces.
2. The assembly of claim 1 wherein the dilatable member is an inflatable bladder that is adapted to be connected to a source of inflation fluid.
3. The assembly of claim 1 wherein the cutting element is permanently affixed to the exterior surface of the inflatable member.
4. The assembly of claim 1 wherein the cutting element is removably carried on the exterior of the inflatable member.
5. The assembly of claim 1 wherein the cutting element is an integral component of the dilatable member.
6. The assembly of claim 1 wherein the cutting element comprises a thin wire.
7. The assembly of claim 1 including means for heating the cutting element to a temperature that permits incision and cauterization of the tissue.
8. The assembly of claim 1 including an open ended sheath in which the tubular body is housed and from

which the tubular body may be ejected for use and into which the tubular body may be retracted after use.

5 9. A method for dilating a body conduit, vessel
or orifice comprising: inserting therein a dilatation
catheter assembly comprising an elongated tubular body
having a distal end carrying a radially dilatable member
adapted to dilate and exert pressure on surrounding body
tissue and a cutting element carried on the exterior of
10 the dilatable member; dilating the dilatable member to an
extent that causes the tissue to be simultaneously
stressed by the dilatable member and incised by the cut-
ting member; radially contracting the dilatable member to
cause the dilatable member and cutting element to dis-
15 engage the tissue; and withdrawing the dilatation catheter
assembly therefrom.

10 10. The method of claim 9 including the step of
heating the cutting element while it is in contact with
20 the incised tissue to a temperature that causes said tis-
sue to be cauterized.

25

30

35

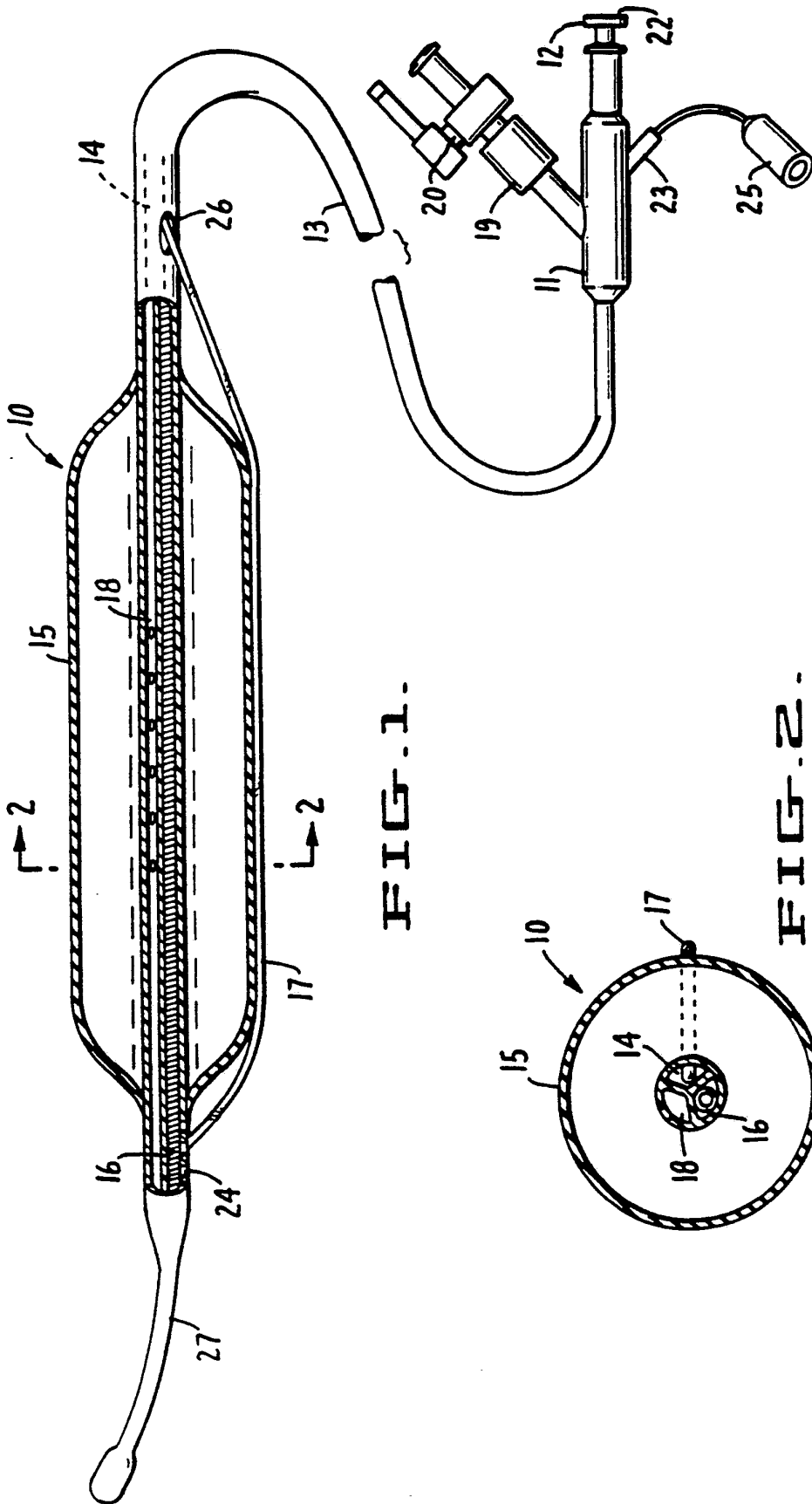

FIG. 1.

FIG. 2.

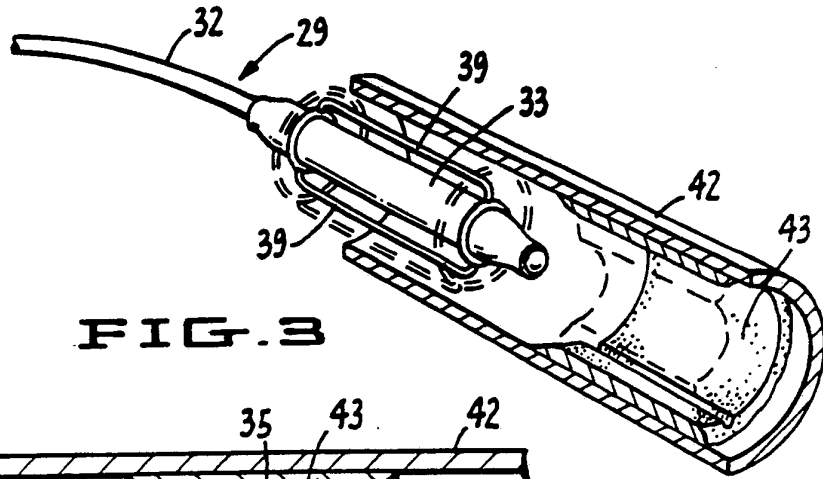

FIG. 3

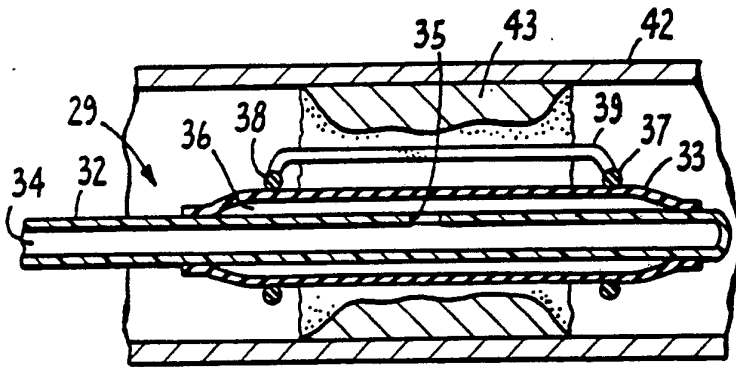

FIG. 4.

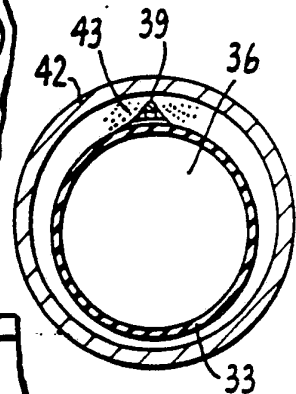

FIG. 6.

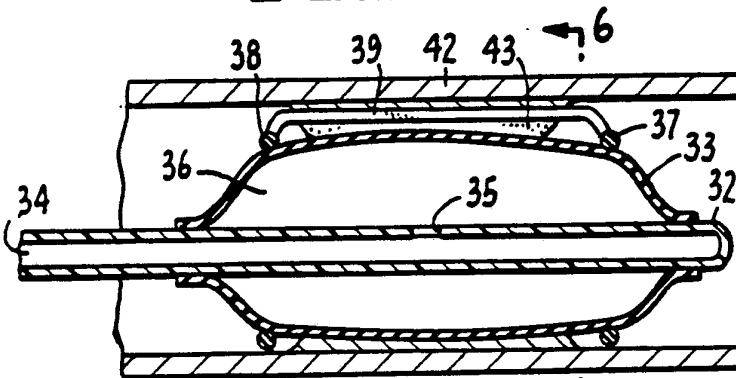

FIG. 5.

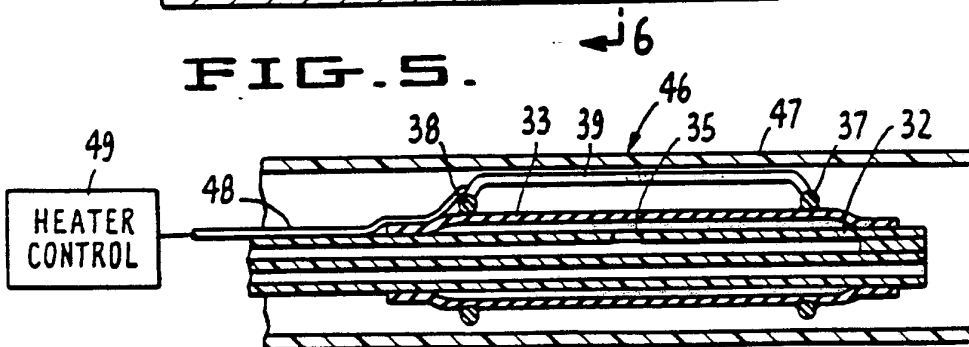

FIG. 7.

INTERNATIONAL SEARCH REPORT

International Application No. **PCT/US90/00337**

I. CLASSIFICATION OF SUBJECT MATTER (if several classification symbols apply, indicate all) ⁶		
According to International Patent Classification (IPC) or to both National Classification and IPC		
IPC.(5) A61B 17/32; a61M 29/02		
U.S. CL. 606/27, 170, 194		
II. FIELDS SEARCHED		
Minimum Documentation Searched ⁷		
Classification System	Classification Symbols	
U.S.	127/344, 348.1, 305, 751, 757, 303R, 325, 311 304; 604/22; 606/27-29, 170, 194	
Documentation Searched other than Minimum Documentation to the extent that such Documents are included in the Fields Searched ⁸		
III. DOCUMENTS CONSIDERED TO BE RELEVANT ⁹		
Category [*]	Citation of Document, ¹¹ with indication, where appropriate, of the relevant passages ¹²	Relevant to Claim No. ¹³
Y,P	US, A, 4,799,479 (SPEARS) 24 January 1989 see col. 10, lines 1-40	1-10
Y	US, A, 4,273,128 (LARY) 16 June 1981 see col. 4, lines 47-64	8
Y	SU, A, 938,977 05 July 1982 see entire document.	1-10
A	US, A, 4,747,405 (LECKRONE) 31 May 1988 see entire document.	
<p>[*] Special categories of cited documents: ¹⁰</p> <p>"A" document defining the general state of the art which is not considered to be of particular relevance</p> <p>"E" earlier document but published on or after the international filing date</p> <p>"L" document which may throw doubts on priority claim(s) or which is cited to establish the publication date of another citation or other special reason (as specified)</p> <p>"O" document referring to an oral disclosure, use, exhibition or other means</p> <p>"P" document published prior to the international filing date but later than the priority date claimed</p> <p>"T" later document published after the international filing date or priority date and not in conflict with the application but cited to understand the principle or theory underlying the invention</p> <p>"X" document of particular relevance; the claimed invention cannot be considered novel or cannot be considered to involve an inventive step</p> <p>"Y" document of particular relevance; the claimed invention cannot be considered to involve an inventive step when the document is combined with one or more other such documents, such combination being obvious to a person skilled in the art.</p> <p>"&" document member of the same patent family</p>		
IV. CERTIFICATION		
Date of the Actual Completion of the International Search	Date of Mailing of this International Search Report	
15 March 1990	26 APR 1990	
International Searching Authority	Signature of Authorized Officer	
TSA/IIS	<i>Jerome [Signature]</i> Michael Thaler	