



US 20220356805A1

(19) **United States**

(12) **Patent Application Publication**  
**Hoffman et al.**

(10) **Pub. No.: US 2022/0356805 A1**

(43) **Pub. Date: Nov. 10, 2022**

(54) **AIRFOIL ASSEMBLY WITH A FLUID CIRCUIT**

(52) **U.S. Cl.**  
CPC ..... **F01D 5/18** (2013.01); **F01D 5/187** (2013.01); **F01D 9/041** (2013.01); **F01D 25/12** (2013.01); **F05D 2260/202** (2013.01); **Y02T 50/60** (2013.01); **F05D 2220/323** (2013.01); **F05D 2240/12** (2013.01); **F05D 2240/30** (2013.01); **F05D 2240/81** (2013.01); **F05D 2260/20** (2013.01)

(71) Applicant: **General Electric Company**,  
Schenectady, NY (US)

(72) Inventors: **James Michael Hoffman**, Hamilton  
Township, OH (US); **Danielle Leigh Polizzi**, West Chester, OH (US)

(21) Appl. No.: **17/864,595**

(57) **ABSTRACT**

(22) Filed: **Jul. 14, 2022**

**Related U.S. Application Data**

(63) Continuation of application No. 15/343,849, filed on  
Nov. 4, 2016, now Pat. No. 11,401,817.

An airfoil assembly for a gas turbine engine having a core with a working airflow. The airfoil assembly comprising a dovetail, a platform, an airfoil, a fluid circuit and at least one curvilinear cooling passage. The platform extending from the dovetail and having an outer surface confronting the working airflow. The at least one curvilinear fluid passage extending between an inlet in direct fluid communication with the fluid circuit and an outlet on the outer surface.

**Publication Classification**

(51) **Int. Cl.**  
**F01D 5/18** (2006.01)  
**F01D 9/04** (2006.01)  
**F01D 25/12** (2006.01)

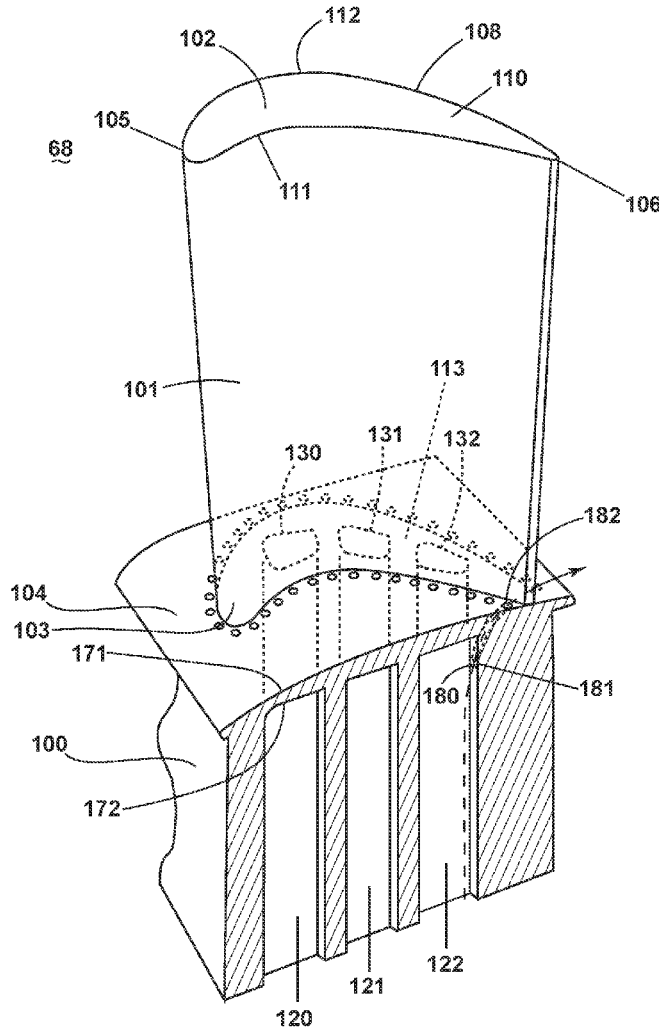

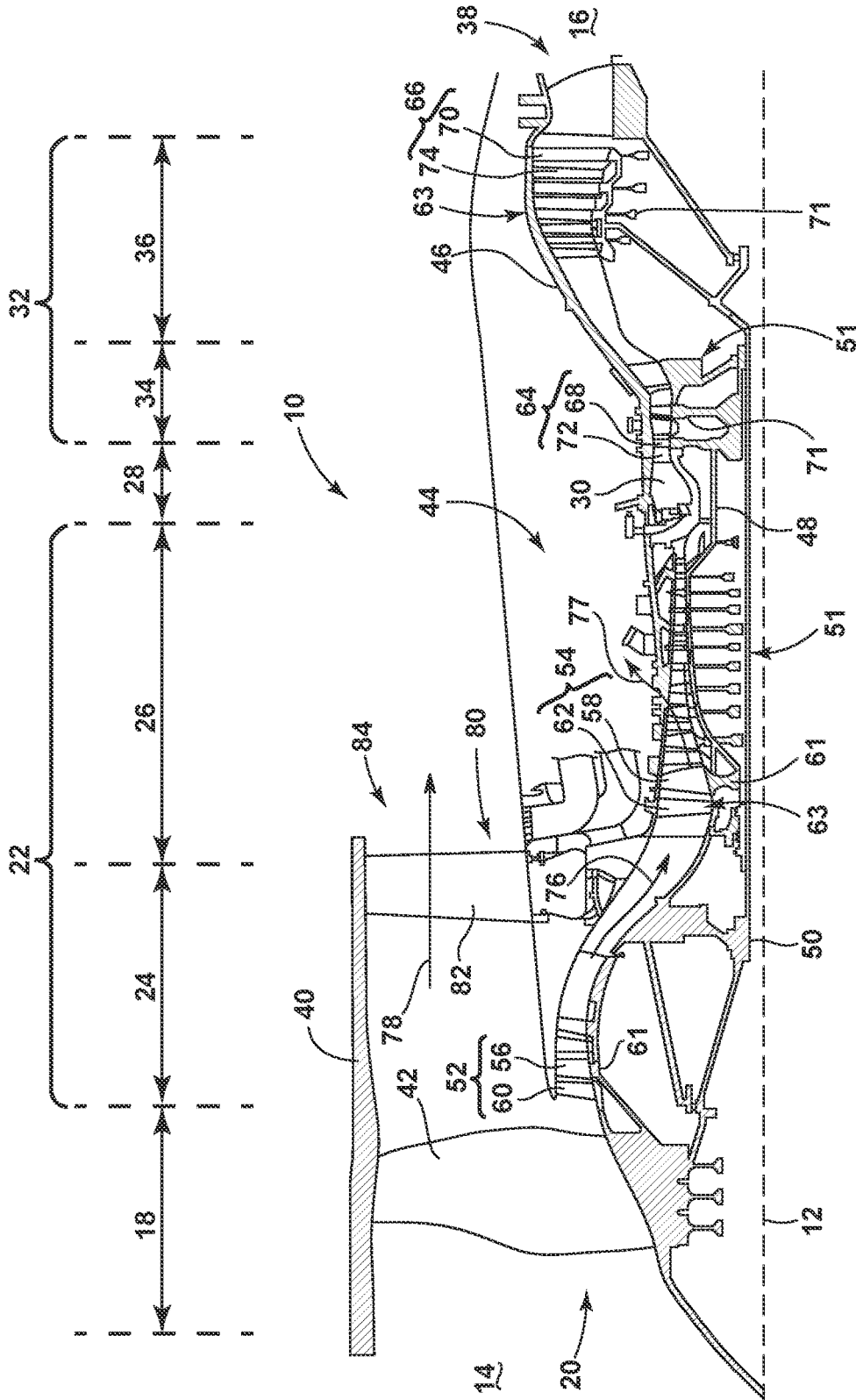

FIG. 1



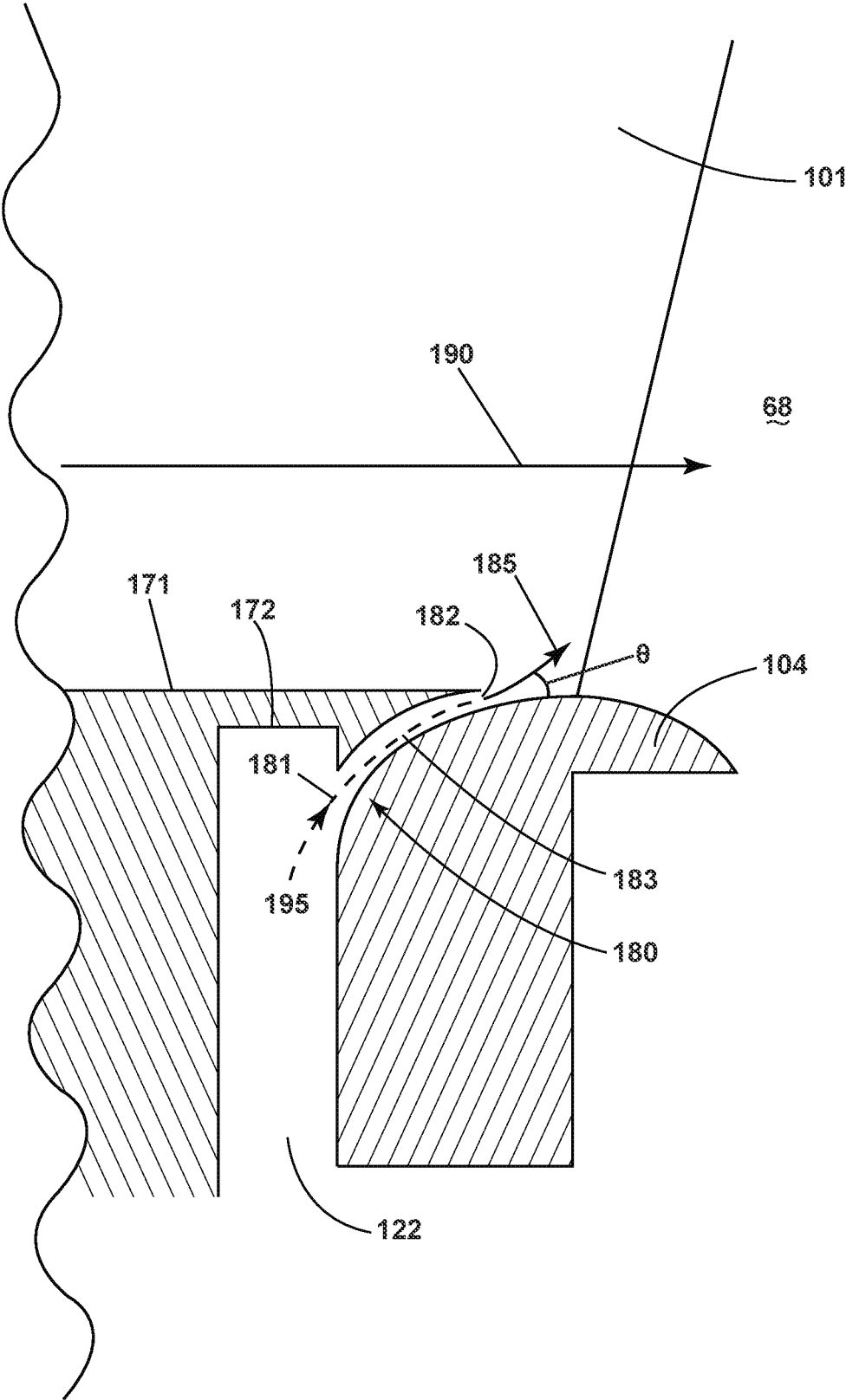

FIG. 3

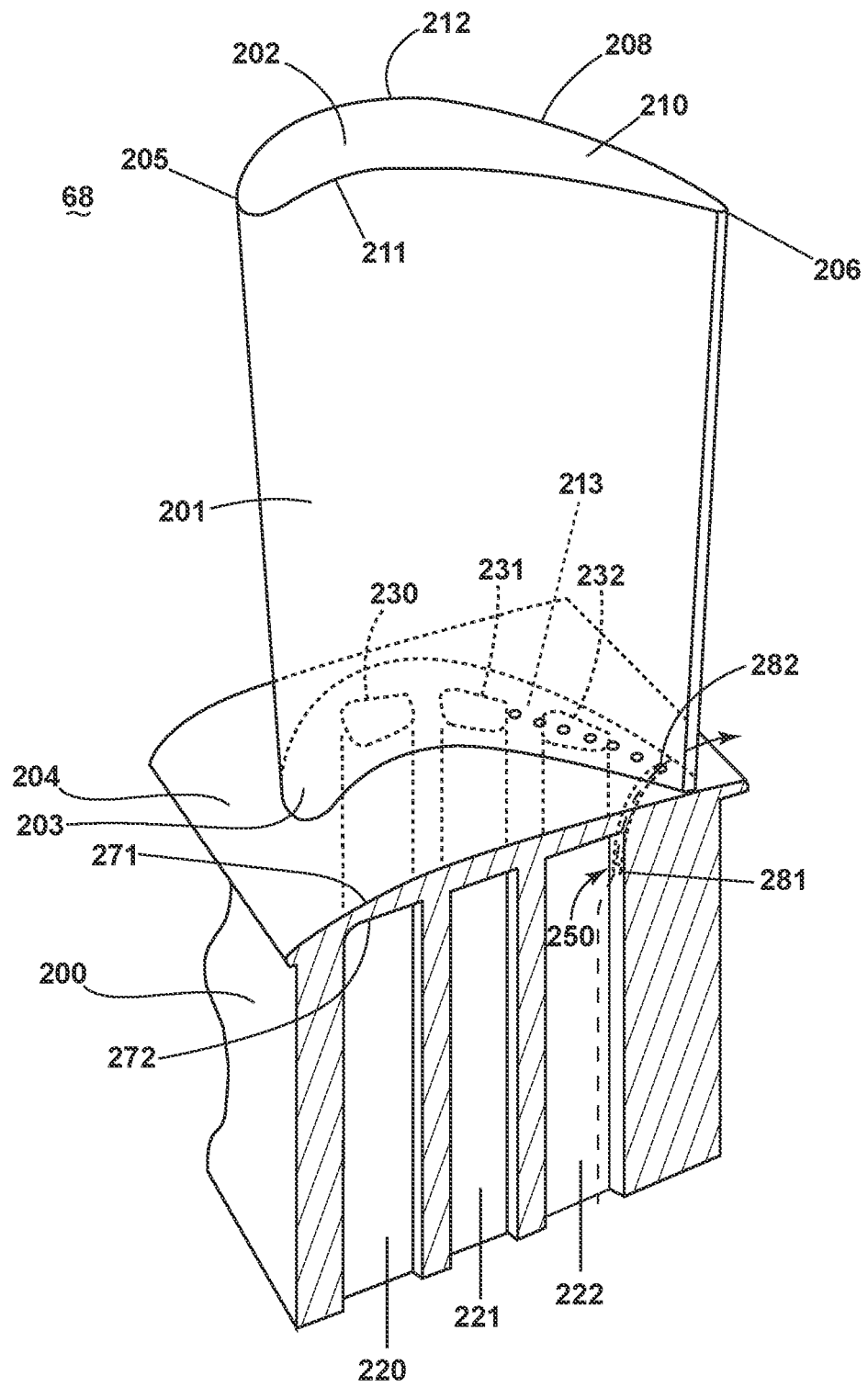

FIG. 4

## AIRFOIL ASSEMBLY WITH A FLUID CIRCUIT

### BACKGROUND OF THE INVENTION

**[0001]** Turbine engines, and particularly gas or combustion turbine engines, are rotary engines that extract energy from a flow of combusted gases passing through the engine onto a multitude of rotating turbine blades.

**[0002]** Gas turbine engines for aircraft are designed to operate at high temperatures to maximize engine efficiency, so cooling of certain engine components, such as the high pressure turbine and the low pressure turbine, can be beneficial. Typically, cooling is accomplished by ducting cooler air from the high and/or low pressure compressors to the engine components that require cooling. Temperatures in the high pressure turbine are around 1000° C. to 2000° C. and the cooling air from the compressor is around 500° C. to 700° C. While the compressor air is a high temperature, it is cooler relative to the turbine air, and can be used to cool the turbine.

**[0003]** Contemporary turbine blades, as well as vanes or nozzles, generally include one or more interior cooling circuits for routing the cooling air through the blade to cool different portions of the blade, and can include dedicated cooling circuits for cooling different portions of the blade, such as the leading edge, trailing edge, and tip of the blade.

### BRIEF DESCRIPTION OF THE INVENTION

**[0004]** In one aspect, an airfoil assembly for a turbine engine comprises a platform having first and second opposing surfaces, an airfoil extending from the first surface of the platform and having an outer wall bounding an interior and defining a pressure side and a suction side extending axially from a leading edge to a trailing edge to define a chord-wise direction and extending radially between a root and a tip to define a span-wise direction, with the root being adjacent the platform, a cooling passage located within the airfoil and passing through the platform and into the interior of the airfoil, and at least one curvilinear cooling passage having an inlet in fluid communication with the cooling circuit and an outlet on the first surface.

**[0005]** In another aspect, a blade for a turbine engine comprises a platform having first and second opposing surfaces, a dovetail extending from the second surface, an airfoil extending from the first surface and having an outer wall bounding an interior and defining a pressure side and a suction side extending axially between a leading edge to a trailing edge to define a chord-wise direction and extending radially between a root and a tip to define a span-wise direction, with the root being adjacent the platform, a cooling circuit passing through the dovetail, platform and into the interior of the airfoil, and at least one curvilinear cooling passage having an inlet in fluid communication with the cooling circuit and an outlet on the first surface.

**[0006]** In yet another aspect, embodiments relate to a method of cooling an airfoil for a turbine engine, the method comprising passing cooling air through a curvilinear passage in a platform supporting the airfoil and emitting the cooling air through an outlet adjacent a root of the airfoil.

### BRIEF DESCRIPTION OF THE DRAWINGS

**[0007]** In the drawings:

**[0008]** FIG. 1 is a schematic cross-sectional diagram of a gas turbine engine for an aircraft.

**[0009]** FIG. 2 is a schematic perspective view of a blade of the turbine engine of FIG. 1 according to a first embodiment of the invention.

**[0010]** FIG. 3 is a schematic cross-sectional view of a portion of a cooling circuit in the blade of FIG. 2.

**[0011]** FIG. 4 is a schematic perspective view of a blade of the turbine engine of FIG. 1 according to a second embodiment of the invention.

### DESCRIPTION OF EMBODIMENTS OF THE INVENTION

**[0012]** The described embodiments of the present invention are directed to curvilinear cooling passages or film holes in either or both of a platform or dovetail of a turbine blade. For purposes of illustration, the embodiments of the present invention will be described with respect to the turbine for an aircraft gas turbine engine. It will be understood, however, that the disclosure is not so limited and may have general applicability within an engine, including compressors, as well as in non-aircraft applications, such as other mobile applications and non-mobile industrial, commercial, and residential applications.

**[0013]** As used herein, the term “forward” or “upstream” refers to moving in a direction toward the engine inlet, or a component being relatively closer to the engine inlet as compared to another component. The term “aft” or “downstream” used in conjunction with “forward” or “upstream” refers to a direction toward the rear or outlet of the engine or being relatively closer to the engine outlet as compared to another component.

**[0014]** Additionally, as used herein, the terms “radial” or “radially” refer to a dimension extending between a center longitudinal axis of the engine and an outer engine circumference.

**[0015]** All directional references (e.g., radial, axial, proximal, distal, upper, lower, upward, downward, left, right, lateral, front, back, top, bottom, above, below, vertical, horizontal, clockwise, counterclockwise, upstream, downstream, forward, aft, etc.) are only used for identification purposes to aid the reader’s understanding of the present invention, and do not create limitations, particularly as to the position, orientation, or use of the invention. Connection references (e.g., attached, coupled, connected, and joined) are to be construed broadly and can include intermediate members between a collection of elements and relative movement between elements unless otherwise indicated. As such, connection references do not necessarily infer that two elements are directly connected and in fixed relation to one another. The exemplary drawings are for purposes of illustration only and the dimensions, positions, order and relative sizes reflected in the drawings attached hereto can vary.

**[0016]** FIG. 1 is a schematic cross-sectional diagram of a gas turbine engine 10 for an aircraft. The engine 10 has a generally longitudinally extending axis or centerline 12 extending forward 14 to aft 16. The engine 10 includes, in downstream serial flow relationship, a fan section 18 including a fan 20, a compressor section 22 including a booster or low pressure (LP) compressor 24 and a high pressure (HP) compressor 26, a combustion section 28 including a combustor 30, a turbine section 32 including a HP turbine 34, and a LP turbine 36, and an exhaust section 38.

[0017] The fan section 18 includes a fan casing 40 surrounding the fan 20. The fan 20 includes a plurality of fan blades 42 disposed radially about the centerline 12. The HP compressor 26, the combustor 30, and the HP turbine 34 form a core 44 of the engine 10, which generates combustion gases. The core 44 is surrounded by core casing 46, which can be coupled with the fan casing 40.

[0018] A HP shaft or spool 48 disposed coaxially about the centerline 12 of the engine 10 drivingly connects the HP turbine 34 to the HP compressor 26. A LP shaft or spool 50, which is disposed coaxially about the centerline 12 of the engine 10 within the larger diameter annular HP spool 48, drivingly connects the LP turbine 36 to the LP compressor 24 and fan 20. The spools 48, 50 are rotatable about the engine centerline and couple to a plurality of rotatable elements, which can collectively define a rotor 51.

[0019] The LP compressor 24 and the HP compressor 26 respectively include a plurality of compressor stages 52, 54, in which a set of compressor blades 56, 58 rotate relative to a corresponding set of static compressor vanes 60, 62 (also called a nozzle) to compress or pressurize the stream of fluid passing through the stage. In a single compressor stage 52, 54, multiple compressor blades 56, 58 can be provided in a ring and can extend radially outwardly relative to the centerline 12, from a blade platform to a blade tip, while the corresponding static compressor vanes 60, 62 are positioned upstream of and adjacent to the rotating blades 56, 58. It is noted that the number of blades, vanes, and compressor stages shown in FIG. 1 were selected for illustrative purposes only, and that other numbers are possible.

[0020] The blades 56, 58 for a stage of the compressor can be mounted to a disk 61, which is mounted to the corresponding one of the HP and LP spools 48, 50, with each stage having its own disk 61. The vanes 60, 62 for a stage of the compressor can be mounted to the core casing 46 in a circumferential arrangement.

[0021] The HP turbine 34 and the LP turbine 36 respectively include a plurality of turbine stages 64, 66, in which a set of turbine blades 68, 70 are rotated relative to a corresponding set of static turbine vanes 72, 74 (also called a nozzle) to extract energy from the stream of fluid passing through the stage. In a single turbine stage 64, 66, multiple turbine blades 68, 70 can be provided in a ring and can extend radially outwardly relative to the centerline 12 while the corresponding static turbine vanes 72, 74 are positioned upstream of and adjacent to the rotating blades 68, 70. It is noted that the number of blades, vanes, and turbine stages shown in FIG. 1 were selected for illustrative purposes only, and that other numbers are possible.

[0022] The blades 68, 70 for a stage of the turbine can be mounted to a disk 71, which is mounted to the corresponding one of the HP and LP spools 48, 50, with each stage having a dedicated disk 71. The vanes 72, 74 for a stage of the compressor can be mounted to the core casing 46 in a circumferential arrangement.

[0023] Complementary to the rotor portion, the stationary portions of the engine 10, such as the static vanes 60, 62, 72, 74 among the compressor and turbine section 22, 32 are also referred to individually or collectively as a stator 63. As such, the stator 63 can refer to the combination of non-rotating elements throughout the engine 10.

[0024] In operation, the airflow exiting the fan section 18 is split such that a portion of the airflow is channeled into the LP compressor 24, which then supplies pressurized air 76 to

the HP compressor 26, which further pressurizes the air. The pressurized air 76 from the HP compressor 26 is mixed with fuel in the combustor 30 and ignited, thereby generating combustion gases. Some work is extracted from these gases by the HP turbine 34, which drives the HP compressor 26. The combustion gases are discharged into the LP turbine 36, which extracts additional work to drive the LP compressor 24, and the exhaust gas is ultimately discharged from the engine 10 via the exhaust section 38. The driving of the LP turbine 36 drives the LP spool 50 to rotate the fan 20 and the LP compressor 24.

[0025] A portion of the pressurized airflow 76 can be drawn from the compressor section 22 as bleed air 77. The bleed air 77 can be drawn from the pressurized airflow 76 and provided to engine components requiring cooling. The temperature of pressurized airflow 76 entering the combustor 30 is significantly increased. As such, cooling provided by the bleed air 77 is necessary for operating of such engine components in the heightened temperature environments.

[0026] A remaining portion of the airflow 78 bypasses the LP compressor 24 and engine core 44 and exits the engine assembly 10 through a stationary vane row, and more particularly an outlet guide vane assembly 80, comprising a plurality of airfoil guide vanes 82, at the fan exhaust side 84. More specifically, a circumferential row of radially extending airfoil guide vanes 82 are utilized adjacent the fan section 18 to exert some directional control of the airflow 78.

[0027] Some of the air supplied by the fan 20 can bypass the engine core 44 and be used for cooling of portions, especially hot portions, of the engine 10, and/or used to cool or power other aspects of the aircraft. In the context of a turbine engine, the hot portions of the engine are normally downstream of the combustor 30, especially the turbine section 32, with the HP turbine 34 being the hottest portion as it is directly downstream of the combustion section 28. Other sources of cooling fluid can be, but are not limited to, fluid discharged from the LP compressor 24 or the HP compressor 26.

[0028] FIG. 2 is a perspective view of an engine component in the form of one of the turbine blades 68 of the engine 10 from FIG. 1. The turbine blade 68 comprises a dovetail 100, an airfoil 101, and a platform 104. The platform 104 includes a first surface 171 and a second surface 172 where the second surface 172 opposes the first surface 171. The airfoil 101 extends from a tip 102 to a root 103 where the tip 102 and root 103 define a span-wise direction, and the root 103 can be adjacent to and integral with the platform 104. The airfoil 101 also has an outer wall 108 bounding an interior 110. The outer wall 108 defines a pressure side 111 and a suction side 112 extending axially between a leading edge 105 and a trailing edge 106 to define a chord-wise direction. The dovetail 100 is configured to mount to the turbine rotor disk 71 on the engine 10 such that the airfoil 101 projects radially from the centerline 12 in the span-wise direction. The dovetail 100 can include at least one inlet passage, exemplarily shown as a group of three inlet passages 120, 121, 122, each extending through the dovetail 100 and platform 104 to provide internal fluid communication with the airfoil 101 at a group of three passage outlets 130, 131, 132. The inlet passages 120, 121, 122 form part of a cooling circuit having one or more air flow paths (not shown) through the interior 110 of the turbine blade 68.

[0029] It should be understood that the inlet passages 120, 121, 122 as shown are exemplary and not meant to be

limiting. More or fewer inlet passages can be used to provide a flow of fluid internal of the airfoil **101**. It should be appreciated that the dovetail **100** is shown in cross-section such that the inlet passages **120**, **121**, **122** are housed within the body of the dovetail **100**. It should be further appreciated that the embodiments as described herein are related to an airfoil **101**, however, this should not be construed as limiting of the invention and additional engine components such as a blade, vane, strut, or shroud assembly, in non-limiting examples, can be substituted for the airfoil.

[0030] The cooling circuit can further include a curvilinear cooling passage **180** having an inlet **181** formed in the dovetail in fluid communication with the cooling circuit, and an outlet **182** formed on the first surface **171** of the platform **104** adjacent to the root **103** of the airfoil **101** and exterior to the airfoil **101**. The outlet **182** can be located adjacent to a portion or an entirety of the blade **68**, or it can also be located above the suction side **112** of the airfoil **101** along a rear half **113** of the airfoil **101**. It is contemplated that the outlet **182** can be any shape including but not limited to a diffuser, an oval, a circle, or any other shape appropriate for the curvilinear cooling passage **180** known in the art. It is further contemplated that the curvilinear cooling passage **180** can be multiple passages with inlets **120**, **121**, **122** in fluid communication with the cooling circuit and outlets **130**, **131**, **132** as described herein.

[0031] FIG. 3 is a cross-sectional view of a portion of the cooling circuit in FIG. 2. The curvilinear cooling passage **180** includes the inlet **181** in fluid communication with the cooling circuit and the outlet **182** on the first surface **171** of the platform **104**. A centerline **183** extends through the curvilinear cooling passage **180**. At the outlet **182**, the centerline **183** defines a path **185** that forms an included angle  $\theta$  that, when measured from the first surface **171**, is an acute angle less than 30 degrees. In some embodiments, the included angle  $\theta$  can also be less than 20 degrees. In addition, an exemplary external flow streamline **190** is illustrated as running substantially parallel to the platform **104**. It is understood that the curvilinear cooling passage **180** as described above can be applied to any of the exemplary curvilinear passages in all embodiments as described herein and is not meant to be limiting.

[0032] Turning to FIG. 4, a second embodiment similar to the first embodiment is illustrated with like parts identified by like numerals increasing by **100**. It is to be understood that the description of the like parts of the first embodiment applies to the second embodiment unless otherwise noted.

[0033] A cooling circuit in a turbine blade **68** is illustrated having a curvilinear cooling passage **280** with an inlet **281** in fluid communication with the cooling circuit and an outlet **282** located on a first surface **271** of a platform **204** on an interior **210** of an airfoil **201**. The outlet **282** can be located at, but not limited to, a rear half **213** of the interior **210** of the airfoil **201** in the chord-wise direction. It is also contemplated that the curvilinear cooling passage **280** can be multiple passages with inlets **281** in fluid communication with the cooling circuit provided at multiple locations within the interior **210** and outlets **282** on the first surface as described herein.

[0034] In all embodiments described herein the formation of the curvilinear cooling passages **180**, **280** can be achieved by methods including, but not limited to, additive manufacturing. It should be appreciated that additive manufacturing processes enable the manufacture of intricate parts or fea-

tures at reduced cost and improved accuracy compared with traditional manufacturing methods. Casting and drilling can also be contemplated, or any other appropriate form of manufacturing known in the art.

[0035] A method of cooling the airfoil **101** for the turbine engine **10** includes passing the cooling air **195** through the curvilinear cooling passage **180** and emitting the cooling air **195** through the outlet **182**. The cooling air is emitted along the path **185** that can form an included angle  $\theta$  relative to the platform **104**. The cooling air **195** can be emitted at an aft half of the airfoil **101**, and can also be emitted adjacent a root **103** of the airfoil **101** or in the interior of the airfoil **101**. The included angle  $\theta$  can be less than 20 degrees or as close to zero as possible such that the cooling air emerging from the outlet **182** can align with the flow streamline **190** to form a cooling film on the first surface **171**.

[0036] The curvilinear cooling passage **180** can be positioned to supply cooling air to locations in the airfoil **101** or platform **104** that were previously unreachable using line-of-sight or other known drilling methods. It is also contemplated that the outlet **182** of the curvilinear cooling passage **180** can be aligned with the external flow streamline **190** about the airfoil **101** in order to reduce areas of low air flow or flow separation in or around the airfoil **101** or platform **104**, resulting in improved cooling efficacy. It can be further contemplated that multiple curvilinear cooling passages **180** can be formed in a group of nearby cavities in the airfoil **101** or platform **104** in order to control environmental conditions near the blade **68** such as pressure ratio, blowing ratio, or backflow margin.

[0037] It should be appreciated that application of the disclosed design is not limited to turbine engines with fan and booster sections, but is applicable to turbojets and turbo engines as well.

[0038] This written description uses examples to disclose the present invention, including the best mode, and also to enable any person skilled in the art to practice the invention, including making and using any devices or systems and performing any incorporated methods. The patentable scope of the invention is defined by the claims, and may include other examples that occur to those skilled in the art. Such other examples are intended to be within the scope of the claims if they have structural elements that do not differ from the literal language of the claims, or if they include equivalent structural elements with insubstantial differences from the literal languages of the claims.

1-20. (canceled)

21. An airfoil assembly for a turbine engine having a core with a working airflow, the airfoil assembly comprising:

- a dovetail;
- a platform extending from the dovetail and having an outer surface confronting the working airflow;
- an airfoil extending from the outer surface and having an outer wall bounding an interior and defining a pressure side and a suction side extending axially between a leading edge to a trailing edge and extending radially between a root and a tip, with the root being adjacent the platform;
- a fluid circuit formed at least partially within the dovetail and being fluidly coupled to the interior of the airfoil; and
- at least one curvilinear fluid passage having a single continuous bend including and extending between an



inlet in direct fluid communication with the fluid circuit and an outlet on the outer surface.

**22.** The airfoil assembly of claim **21**, wherein the at least one curvilinear fluid passage defines a centerline, which at the outlet, defines an included angle with the outer surface.

**23.** The airfoil assembly of claim **22**, wherein the included angle is less than 30 degrees.

**24.** The airfoil assembly of claim **23**, wherein the included angle is less than 20 degrees.

**25.** The airfoil assembly of claim **21**, wherein the at least one curvilinear fluid passage defines a plurality of curvilinear fluid passages, each extending between a corresponding inlet and outlet.

**26.** The airfoil assembly of claim **25**, wherein at least some of the plurality of curvilinear fluid passages have their outlets aligned with a flow streamline about the airfoil.

**27.** The airfoil assembly of claim **21**, wherein the at least one curvilinear fluid passage is cast within the platform.

**28.** The airfoil assembly of claim **21**, wherein the outlet is located in a rear half of the airfoil in a chord-wise direction.

**9.** The airfoil assembly of claim **21**, wherein the outlet is located above the suction side.

**30.** An airfoil assembly for a turbine engine having a core with a working airflow, the airfoil assembly comprising:

a dovetail;

a platform extending from the dovetail and having an outer surface confronting the working airflow;

an airfoil extending from the outer surface and having an outer wall bounding an interior and defining a pressure side and a suction side extending axially between a leading edge to a trailing edge and extending radially between a root and a tip, with the root being adjacent the platform;

a fluid circuit formed at least partially within the dovetail and being fluidly coupled to the interior of the airfoil; and

at least one curvilinear fluid passage extending between an inlet in direct fluid communication with the fluid circuit and an outlet on the outer surface;

wherein the at least one curvilinear fluid passage defines a centerline, which at the outlet, defines an included angle with the outer surface and the included angle

being less than or equal to 30 degrees and greater than 0 degrees such that the fluid emerging from the outlet can align with a flow streamline of the working airflow to form a fluid film on the outer surface.

**31.** The airfoil assembly of claim **30**, wherein the included angle is less than or equal to 20 degrees.

**32.** The airfoil assembly of claim **30**, wherein the at least one curvilinear fluid passage defines a plurality of curvilinear fluid passages, each extending between a corresponding inlet and outlet.

**33.** The airfoil assembly of claim **32**, wherein each fluid passage of the plurality of curvilinear fluid passages includes a respective included angle.

**34.** The airfoil assembly of claim **32**, wherein at least some of the plurality of curvilinear fluid passages have their outlets aligned with a flow streamline about the airfoil.

**35.** The airfoil assembly of claim **30**, wherein the at least one curvilinear fluid passage is cast within the platform.

**36.** The airfoil assembly of claim **30**, wherein the outlet is located in a rear half of the airfoil in a chord-wise direction.

**37.** The airfoil assembly of claim **30**, wherein the outlet is located above the suction side.

**38.** A method of supplying a fluid to an airfoil for a turbine engine, the airfoil extending from an outer surface of a platform with the outer surface confronting a working airflow of the turbine engine, the method comprising:

supplying fluid air to a fluid circuit within a dovetail to an interior of an airfoil;

passing the fluid through a curvilinear passage having a single continuous bend in the platform, the single continuous bend of the curvilinear passage including and extending between an inlet in direct fluid communication with the fluid circuit and an outlet provided on the outer surface; and

emitting at least a portion of the fluid through the outlet of the curvilinear passage.

**39.** The method of claim **38**, further comprising emitting the fluid from the outlet along a path forming an included angle of less than 30 degrees relative to the platform.

**40.** The method of claim **38**, further comprising emitting the fluid at an aft half of the airfoil.

\* \* \* \* \*