

(12) **UK Patent Application** (19) **GB** (11) **2462441** (13) **A**

(43) Date of A Publication

10.02.2010

(21) Application No: **0814352.1**

(22) Date of Filing: **06.08.2008**

(71) Applicant(s):
Ellen Joanne Crookall
19 Keolestone Avenue, West Park, PLYMOUTH,
PL5 3NE, United Kingdom

(72) Inventor(s):
Ellen Joanne Crookall

(74) Agent and/or Address for Service:
Ellen Joanne Crookall
19 Keolestone Avenue, West Park, PLYMOUTH,
PL5 3NE, United Kingdom

(51) INT CL:
B65D 65/14 (2006.01)

(56) Documents Cited:
CA 002342485 A1 **US 5664675 A**
US 5347789 A **US 2676897 A**
US 20050276971 A1 **US 20050167039 A1**

(58) Field of Search:
INT CL **B65B**
Other: **EPODOC, WPI**

(54) Abstract Title: **Self sealing gift wrap**

(57) A wrapping paper is coated on both sides by an adhesive which will adhere only to another surface coated with that adhesive, allowing an item to be wrapped with the paper sticking only to itself.

Figure 2

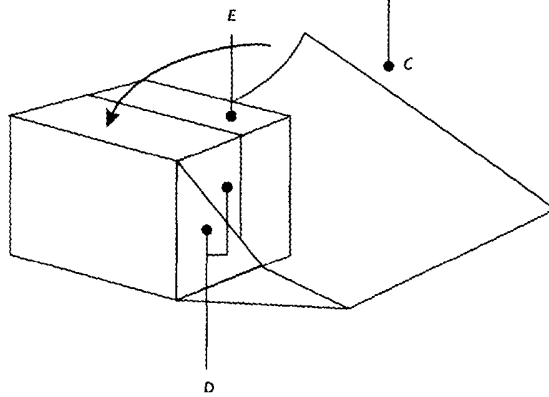

GB 2462441 A

Figure 1

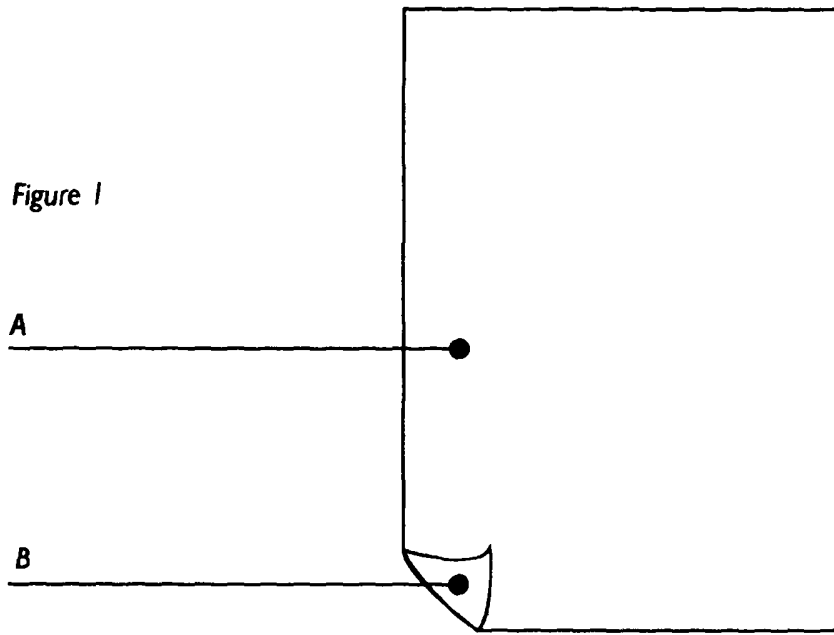
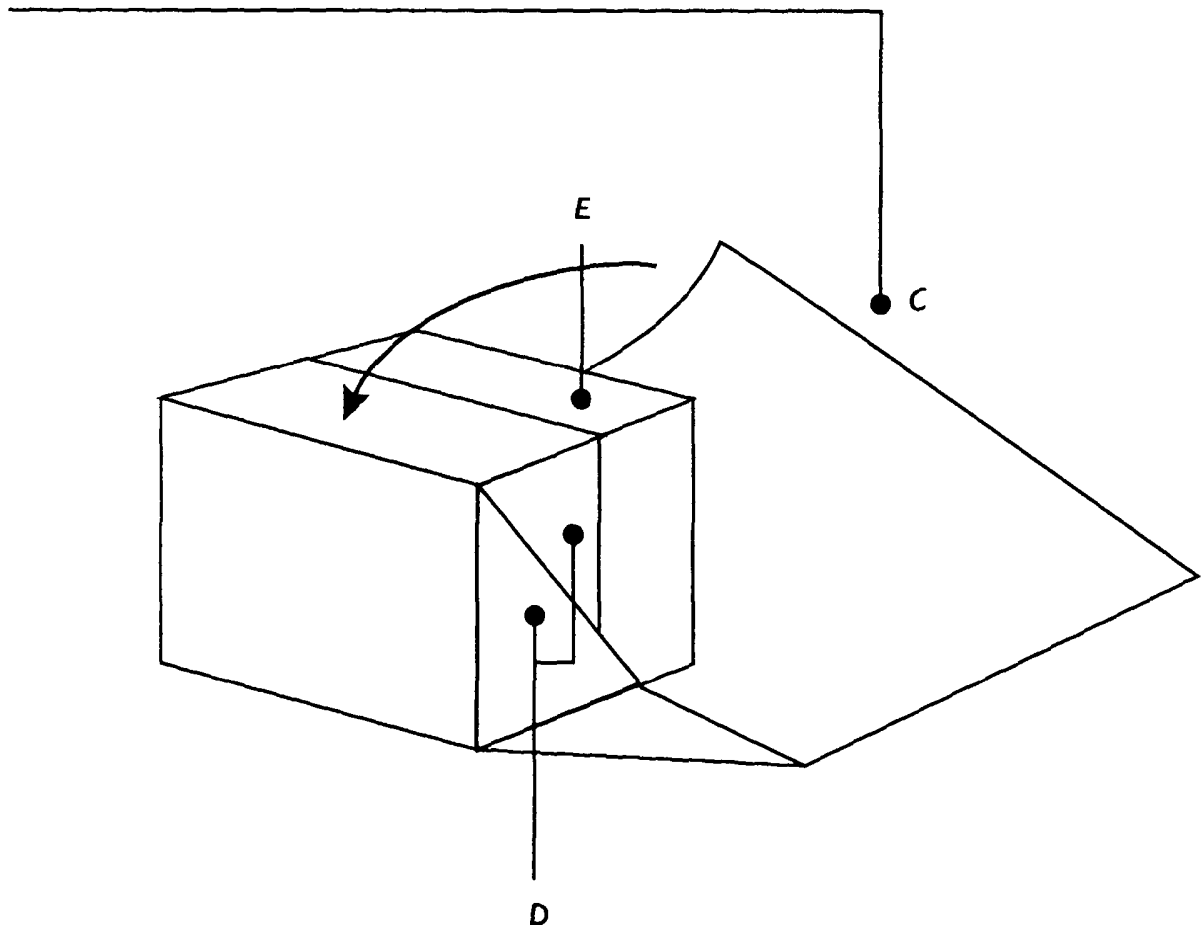

Figure 2



Title

Self Sealing Wrapping Paper/Gift Wrap

Background

Many inconveniences arise when trying to wrap a gift especially if one is in a hurry, namely the amount of time it takes to apply the sticky tape or other forms of sealing and the job is made even harder if said tape or other is unavailable. Sticky tape in particular is unsightly and can crease itself and the paper and can tear the paper if re-positioning is required.

Statement of Invention

The present invention proposes a gift wrap paper coated on both sides with a self-sealing adhesive that will not adhere to any other material other than itself.

Advantages

The advantages of this Self Sealing Wrapping Paper will be that one will not have to purchase separate materials to seal the wrapping such as sticky tape, glue or ties. The gift can be wrapped quickly and neatly without one having to hold down flaps whilst trying to apply sticky tape at the same time. There will be no unsightly tape on the exterior of the gift and the Self Sealing Wrapping Paper can be re-positioned and even re-used. It would be preferable if both the paper and the adhesive used were bio-degradable.

Detailed Description

A sheet of gift wrap paper of any size or design is externally coated completely on both sides with a pressure sensitive, self-sealing adhesive such as Latex 1000 or similar. (*Figure 1, A & B.*) The adhesive will be applied after paper manufacture, but before sales, by a specialist finisher.

As the paper is wrapped around The Object (*Figure 2, E*) the adhesive will not stick to The Object, nor any other surface such as ones hands or work surface.

As the surface of *C* overlaps surface *D*, the two surfaces bond and adhere to each other. The flaps, such as those shown as *D*, can be pressed down and will remain in place as the surfaces bond.

Properties of L1000:

Latex L1000 is normally used for self-sealing envelopes. It can be used on most roller and wheel applicators but must avoid contact with brass or any other alloy containing copper as this will cause failure of bonds.

Machine parts in contact with L1000 should be stainless steel.

Its advantages are; Clean running, minimum down time, easy cleaning from glue tanks and machine parts, good adhesion to a wide range of papers, excellent initial take with short open time, ideal for high speed machines. It should be cleaned with cold water if the adhesive is wet or with warm water if the adhesive has dried.

Components of this product have US FDA approval under CFR section 175.105.

Technical data of L1000:

Solids content c.a. 58%

Viscosity c.a. 1000 mPas @ 4/20/26

Claims

1. A Self-Sealing Self-Adhesive Wrapping Paper which needs no external material to assist in its enclosure of an object and will not adhere to any surface other than which has been coated with the same adhesive.
2. Both sides of the Wrapping Paper will be fully coated in a Self-Sealing adhesive.
3. The Self-Sealing adhesive will activate with pressure when in contact with either side of the wrapping paper but will not adhere to any other surface.

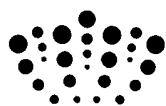

Application No: GB0814352.1

Examiner: Mr Philip Osman

Claims searched: 1-3

Date of search: 15 January 2009

Patents Act 1977: Search Report under Section 17

Documents considered to be relevant:

Category	Relevant to claims	Identity of document and passage or figure of particular relevance
X	1, 2	US2005/167039 A1 (WEDER et al) See paragraph 36 in particular
X	1, 3	US5664675 A (WEDER) See Column 4 lines 8-21 and column 5 line 42 - column 6 line 5
X	1	US5347789 A (WEDER) See abstract and figures
A	-	US2005/276971 A1 (KITCHIN et al) See abstract and figures
A	-	CA2342485 A1 (METCALF) See abstract and figures
A	-	US2676897 A (MUNISING PAPER COMPANY) See whole document

Categories:

X	Document indicating lack of novelty or inventive step	A	Document indicating technological background and/or state of the art.
Y	Document indicating lack of inventive step if combined with one or more other documents of same category.	P	Document published on or after the declared priority date but before the filing date of this invention.
&	Member of the same patent family	E	Patent document published on or after, but with priority date earlier than, the filing date of this application.

Field of Search:

Search of GB, EP, WO & US patent documents classified in the following areas of the UKC^X :

Worldwide search of patent documents classified in the following areas of the IPC
B65B
The following online and other databases have been used in the preparation of this search report
EPODOC, WPI

International Classification:

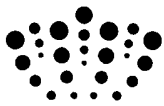

Subclass	Subgroup	Valid From
B65D	0065/14	01/01/2006