



US00D477915S

(12) **United States Design Patent** (10) **Patent No.:** **US D477,915 S**
Slight (45) **Date of Patent:** **** Aug. 5, 2003**

(54) **TRAY**
(75) **Inventor:** **Peter T. Slight, Newmarket (CA)**
(73) **Assignee:** **Traitech Industries, Inc., North York (CA)**
(**) **Term:** **14 Years**

4,669,609 A * 6/1987 Lugo 206/229
4,867,329 A * 9/1989 Dieter 206/557
5,007,552 A * 4/1991 Sage et al. D7/555
D385,920 S * 11/1997 Tisbo D19/75
D428,701 S * 8/2000 Lamo, Jr. D3/313
D453,995 S * 3/2002 Slight D3/304

* cited by examiner

(21) **Appl. No.:** **29/156,954**
(22) **Filed:** **Mar. 12, 2002**

Primary Examiner—Louis S. Zarfaz
Assistant Examiner—Deanne Levy
(74) *Attorney, Agent, or Firm*—Dimock Stratton Clarizio;
Mark B. Eisen

(30) **Foreign Application Priority Data**
Feb. 18, 2002 (CA) 98677

(57) **CLAIM**

The ornamental design for a tray, as shown and described.

(51) **LOC (7) Cl.** **03-01**
(52) **U.S. Cl.** **D3/313**
(58) **Field of Search** D3/304, 313; 206/557,
206/558, 561, 566; D7/550.1, 553.1, 553.2,
553.3, 554.1, 555, 401.1; 211/85.4, 126.1,
126.14, 128.1; 220/570, 500, 553; D19/92,
75; D6/474, 396

DESCRIPTION

FIG. 1 is a top perspective view of the tray;
FIG. 2 is a bottom perspective view thereof;
FIG. 3 is a top plan view thereof;
FIG. 4 is a bottom plan view thereof;
FIG. 5 is a side elevational view thereof, looking from the left side of FIG. 1;
FIG. 6 is a side elevational view thereof, looking from the right side of FIG. 1;
FIG. 7 is a front elevational view thereof; and,
FIG. 8 is a rear elevational view thereof.

(56) **References Cited**
U.S. PATENT DOCUMENTS
D155,124 S * 9/1949 Carver D19/92
2,779,960 A * 2/1957 Ogren 220/570
3,857,482 A * 12/1974 Shelton 206/558
D288,039 S * 2/1987 LeBlanc D6/474

1 Claim, 3 Drawing Sheets

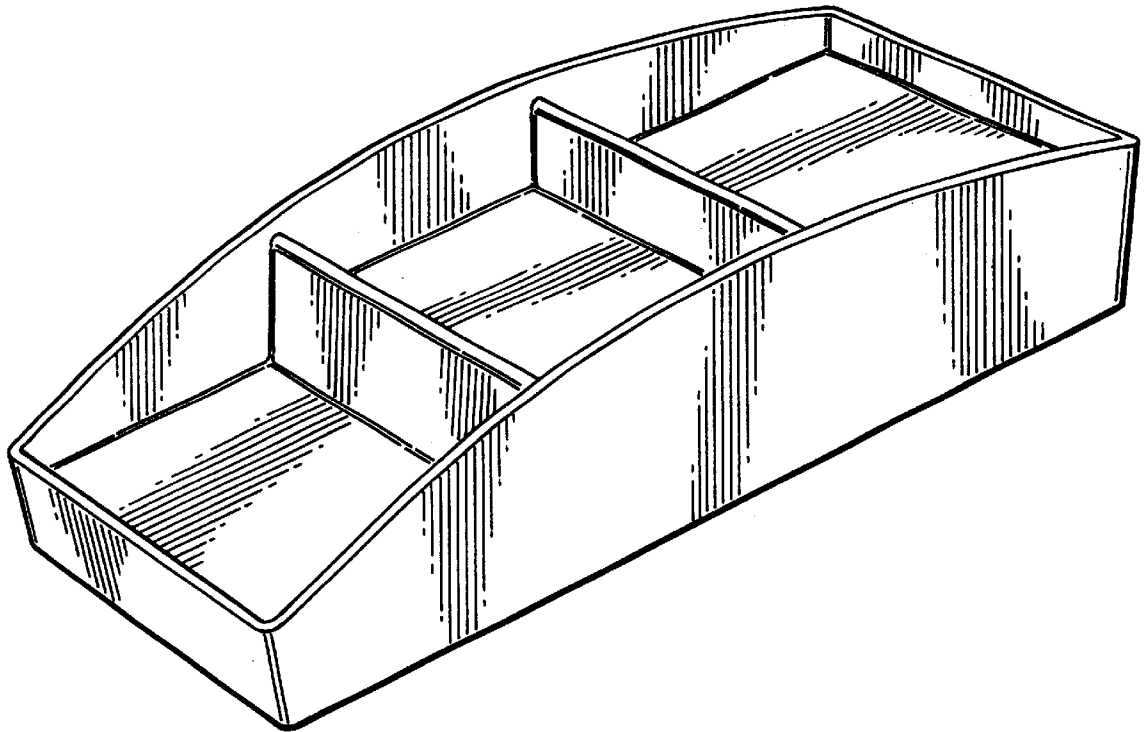

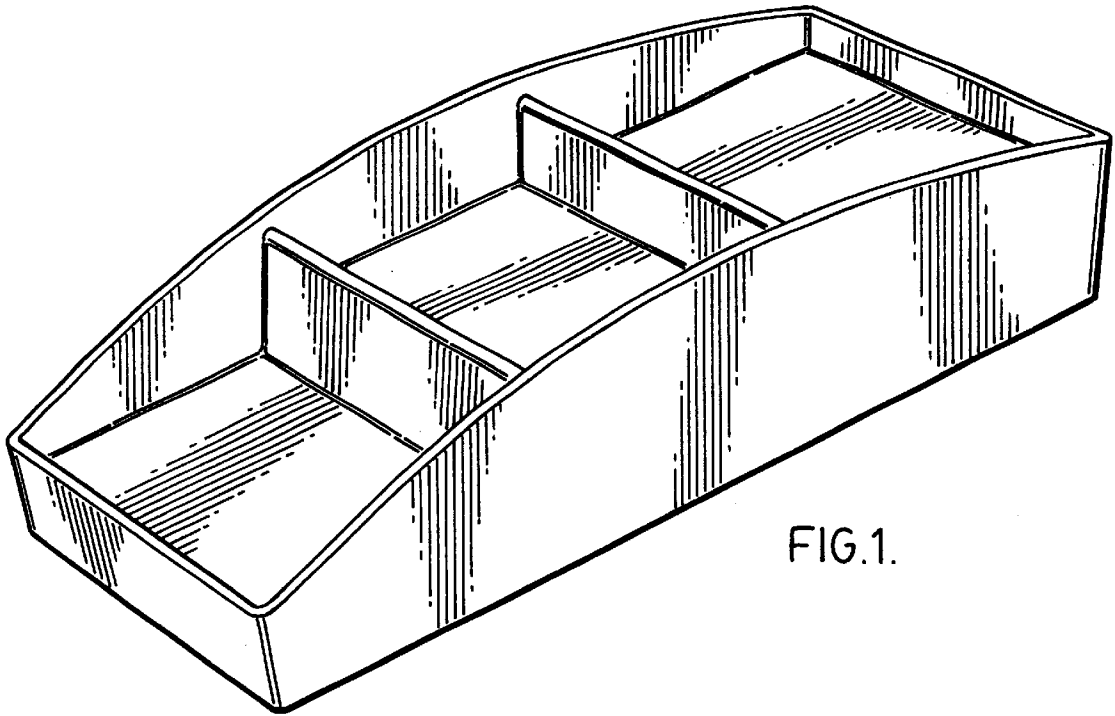

FIG. 1.

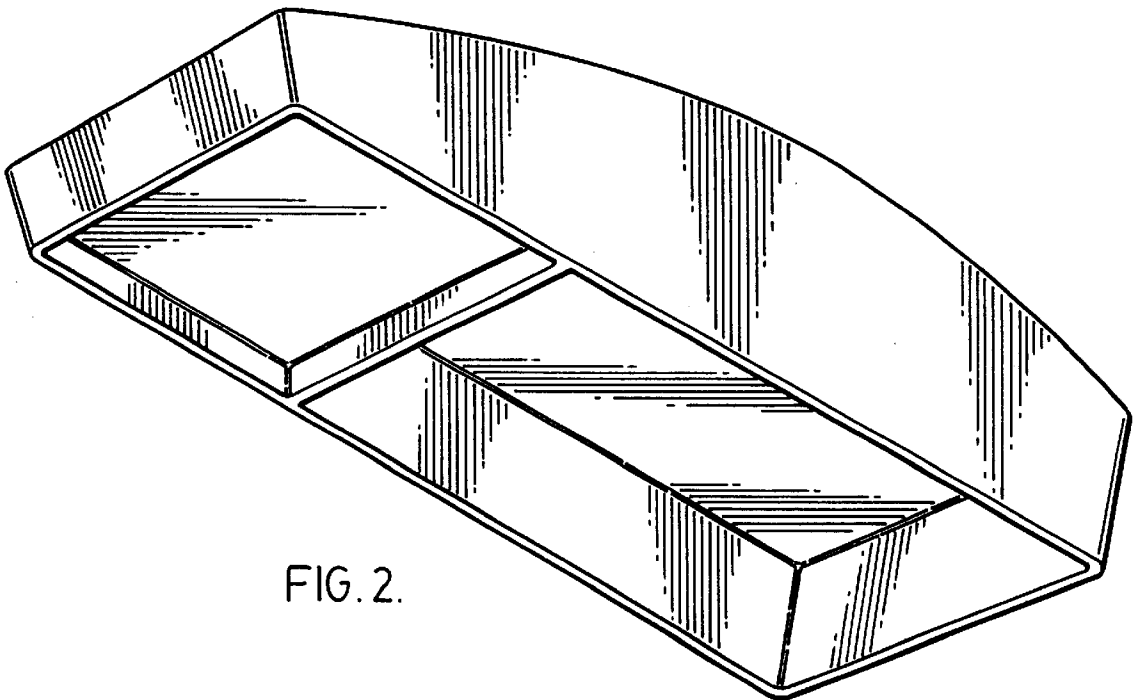

FIG. 2.

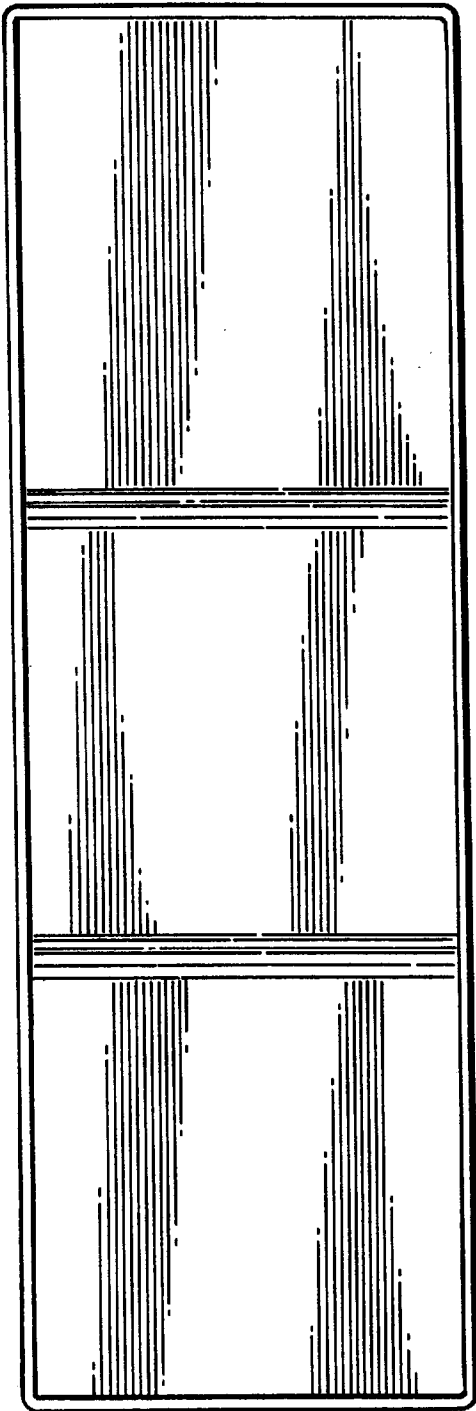

FIG. 3.

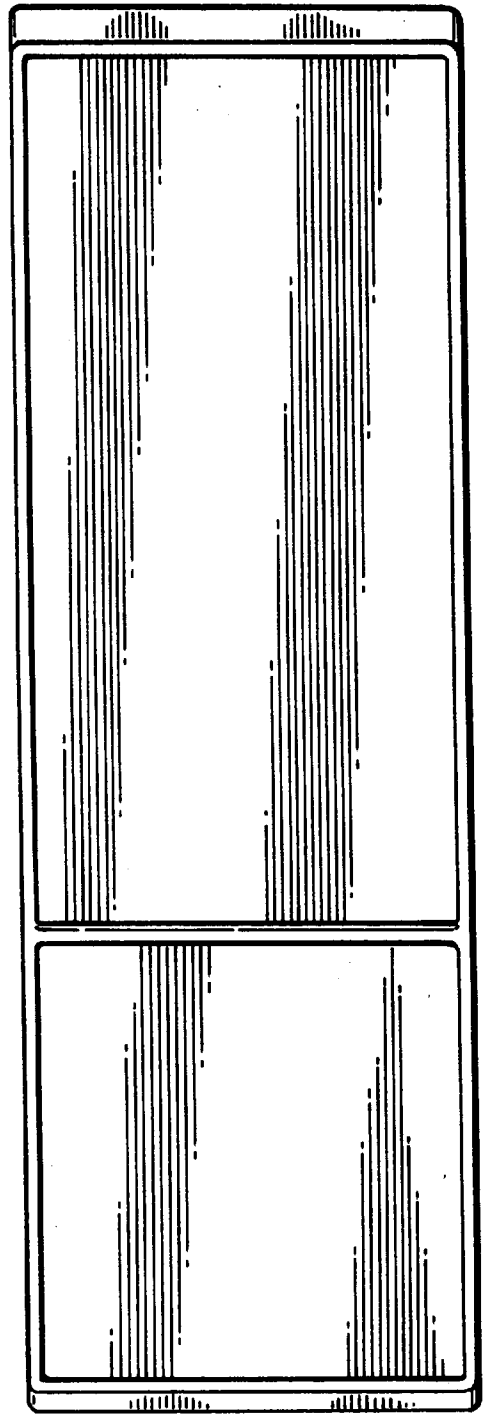

FIG. 4.

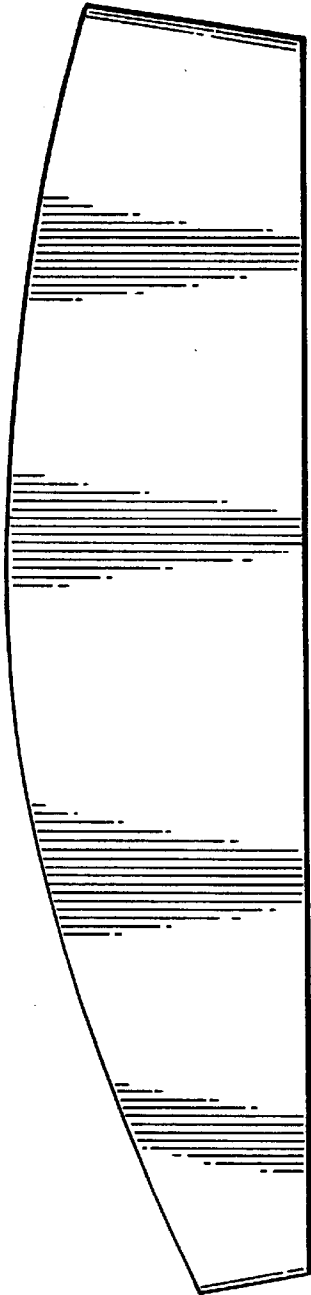

FIG. 5.

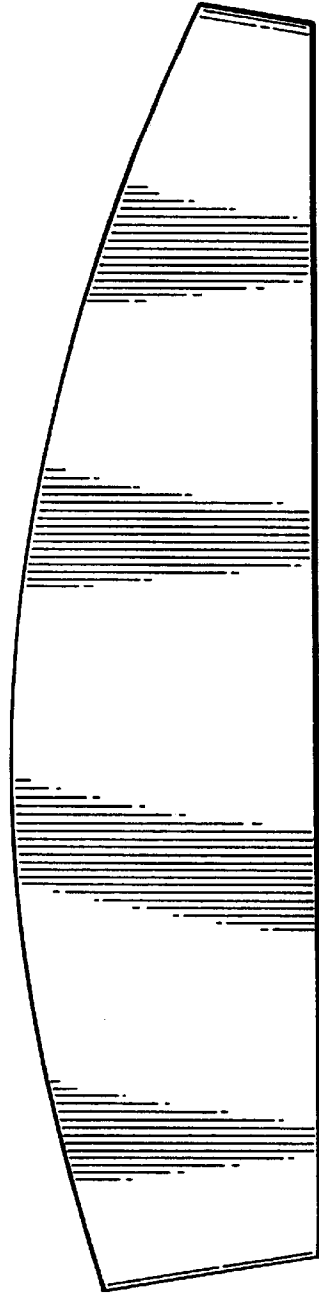

FIG. 6.

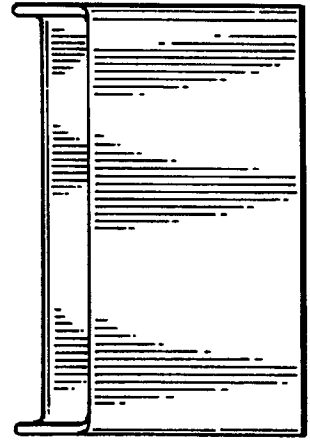

FIG. 8.

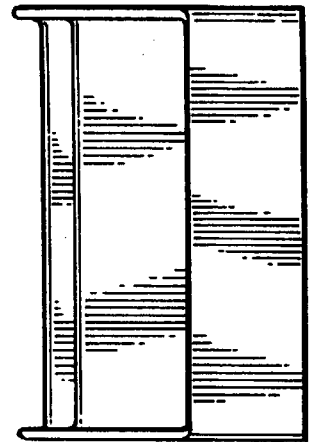

FIG. 7.