

**(12) STANDARD PATENT**  
**(19) AUSTRALIAN PATENT OFFICE**

(11) Application No. **AU 2011271634 B2**

(54) Title  
**Stoichiometric combustion with exhaust gas recirculation and direct contact cooler**

(51) International Patent Classification(s)  
**F02C 3/34** (2006.01)

(21) Application No: **2011271634** (22) Date of Filing: **2011.06.09**

(87) WIPO No: **WO12/003078**

(30) Priority Data

(31) Number	(32) Date	(33) Country
<b>61/361,176</b>	<b>2010.07.02</b>	<b>US</b>

(43) Publication Date: **2012.01.05**

(44) Accepted Journal Date: **2016.01.28**

(71) Applicant(s)  
**ExxonMobil Upstream Research Company**

(72) Inventor(s)  
**Denton, Robert D.;Gupta, Himanshu;Huntington, Richard;Minta, Moses;Mittricker, Franklin F.;Starcher, Loren K.**

(74) Agent / Attorney  
**Watermark Patent and Trade Marks Attorneys, Level 2 302 Burwood Road, HAWTHORN, VIC, 3122**

(56) Related Art  
**US 2008/0104958 A1**  
**US 2008/0309087 A1**  
**US 6957539 B2**  
**WO 2010/044958 A1**  
**US 5832712 A**  
**US 2009/0107141 A1**  
**US 2010/0126181 A1**

(12) INTERNATIONAL APPLICATION PUBLISHED UNDER THE PATENT COOPERATION TREATY (PCT)

(19) World Intellectual Property Organization  
International Bureau



(43) International Publication Date  
5 January 2012 (05.01.2012)

PCT

(10) International Publication Number  
WO 2012/003078 A1

- (51) International Patent Classification: 91935 (US). STARCHER, Loren, K. [US/US]; 3410 Castlebrook Court, Sugar Land, TX 77478 (US).
- (21) International Application Number: PCT/US2011/039828
- (22) International Filing Date: 9 June 2011 (09.06.2011)
- (25) Filing Language: English
- (26) Publication Language: English
- (30) Priority Data: 61/361,176 2 July 2010 (02.07.2010) US
- (71) Applicant (for all designated States except US): EXXONMOBIL UPSTREAM RESEARCH COMPANY [US/US]; P.O. Box 2189 (CORP-URC-SW359), Houston, TX 77252-2189 (US).
- (72) Inventors; and
- (75) Inventors/Applicants (for US only): DENTON, Robert, D. [US/US]; 4314 Phil Street, Bellaire, TX 77401 (US). GUPTA, Himanshu [IN/US]; 9278 Laurel Ridge Crossing Road, Lorton, VA 22079 (US). HUNTINGTON, Richard [US/US]; 12714 Autumn Crest Drive, Oak Hill, VA 20171 (US). MINTA, Moses [US/US]; 7531 Trail Hollow, Missouri City, TX 77459 (US). MITTRICKER, Franklin, F. [US/US]; 14777 Presilla Drive, Jamul, CA
- (74) Agents: TIMMINS, Stephen et al.; EXXONMOBIL UPSTREAM RESEARCH COMPANY, P.O. Box 2189 (CORP-URC-SW359), Houston, TX 77252-2189 (US).
- (81) Designated States (unless otherwise indicated, for every kind of national protection available): AE, AG, AL, AM, AO, AT, AU, AZ, BA, BB, BG, BH, BR, BW, BY, BZ, CA, CH, CL, CN, CO, CR, CU, CZ, DE, DK, DM, DO, DZ, EC, EE, EG, ES, FI, GB, GD, GE, GH, GM, GT, HN, HR, HU, ID, IL, IN, IS, JP, KE, KG, KM, KN, KP, KR, KZ, LA, LC, LK, LR, LS, LT, LU, LY, MA, MD, ME, MG, MK, MN, MW, MX, MY, MZ, NA, NG, NI, NO, NZ, OM, PE, PG, PH, PL, PT, RO, RS, RU, SC, SD, SE, SG, SK, SL, SM, ST, SV, SY, TH, TJ, TM, TN, TR, TT, TZ, UA, UG, US, UZ, VC, VN, ZA, ZM, ZW.
- (84) Designated States (unless otherwise indicated, for every kind of regional protection available): ARIPO (BW, GH, GM, KE, LR, LS, MW, MZ, NA, SD, SL, SZ, TZ, UG, ZM, ZW), Eurasian (AM, AZ, BY, KG, KZ, MD, RU, TJ, TM), European (AL, AT, BE, BG, CH, CY, CZ, DE, DK, EE, ES, FI, FR, GB, GR, HR, HU, IE, IS, IT, LT, LU, LV, MC, MK, MT, NL, NO, PL, PT, RO, RS, SE, SI, SK, SM, TR), OAPI (BF, BJ, CF, CG, CI, CM, GA, GN, GQ, GW, ML, MR, NE, SN, TD, TG).

[Continued on next page]

(54) Title: STOICHIOMETRIC COMBUSTION WITH EXHAUST GAS RECIRCULATION AND DIRECT CONTACT COOLER

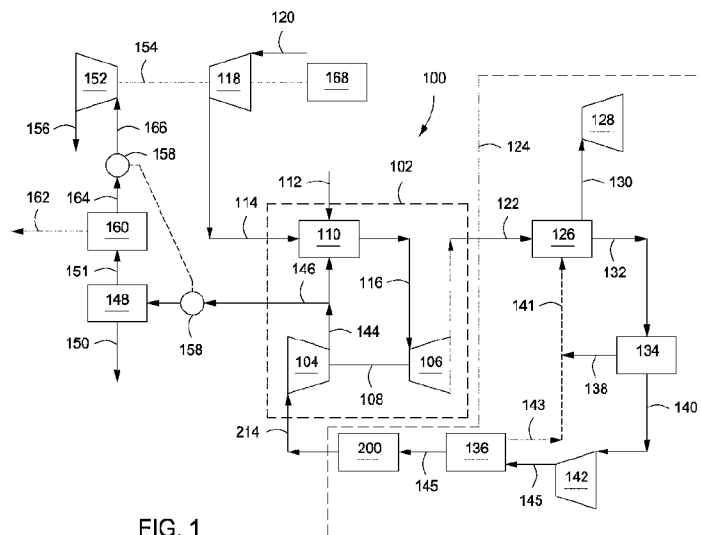

FIG. 1

(57) Abstract: Methods and systems for low emission power generation in hydrocarbon recovery processes are provided. One system includes a gas turbine system configured to stoichiometrically combust a compressed oxidant and a fuel in the presence of a compressed recycle exhaust gas and expand the discharge in an expander to generate a gaseous exhaust stream and drive a main compressor. A boost compressor can receive and increase the pressure of the gaseous exhaust stream and inject it into an evaporative cooling tower configured to use an exhaust nitrogen gas having a low relative humidity as an evaporative cooling media. The cooled gaseous exhaust stream is then compressed and recirculated through the system as a diluent to moderate the temperature of the stoichiometric combustion.

WO 2012/003078 A1



---

**Declarations under Rule 4.17:**

- *as to applicant's entitlement to apply for and be granted a patent (Rule 4.17(ii))*
- *as to the applicant's entitlement to claim the priority of the earlier application (Rule 4.17(iii))*

**Published:**

- *with international search report (Art. 21(3))*
- *before the expiration of the time limit for amending the claims and to be republished in the event of receipt of amendments (Rule 48.2(h))*

**STOICHIOMETRIC COMBUSTION WITH EXHAUST GAS  
RECIRCULATION AND DIRECT CONTACT COOLER**

**CROSS-REFERENCE TO RELATED APPLICATIONS**

5 [0001] This application claims the benefit of U. S. provisional patent application number 61/361,176, filed July 2, 2010 entitled STOICHIOMETRIC COMBUSTION WITH EXHAUST GAS RECIRCULATION AND DIRECT CONTACT COOLER, the entirety of which is incorporated by reference herein.

[0002] This application contains subject matter related to U.S. Patent Application  
10 Number 61/361,169, filed July 2, 2010 entitled "Systems and Methods for Controlling Combustion of a Fuel"; U. S. Patent Application Number 61/361,170, filed July 2, 2010 entitled "Low Emission Triple-Cycle Power Generation Systems and Methods"; U.S. Patent Application Number 61/361,173, filed July 2, 2010, entitled "Low Emission Triple-Cycle Power Generation Systems and Methods"; U.S. Patent Application Number 61/361,178, filed  
15 July 2, 2010, entitled "Stoichiometric Combustion of Enriched Air With Exhaust Gas Recirculation" and U.S. Patent Application Number 61/361,180 filed July 2, 2010, entitled "Low Emission Power Generation Systems and Methods".

**FIELD**

[0003] Embodiments of the disclosure relate to low emission power generation in  
20 combined-cycle power systems.

**BACKGROUND**

[0004] This section is intended to introduce various aspects of the art, which may be associated with exemplary embodiments of the present disclosure. This discussion is believed to assist in providing a framework to facilitate a better understanding of particular  
25 aspects of the present disclosure. Accordingly, it should be understood that this section should be read in this light, and not necessarily as admissions of prior art.

[0005] With the growing concern on global climate change and the impact of CO<sub>2</sub> emissions, emphasis has been placed on CO<sub>2</sub> capture from power plants. This concern combined with the implementation of cap-and-trade policies in many countries make  
30 reducing CO<sub>2</sub> emissions a priority for these and other countries, as well as for the companies that operate hydrocarbon production systems therein.

[0006] Gas turbine combined-cycle power plants are rather efficient and can be operated at relatively low cost when compared to other technologies, such as coal and nuclear. Capturing CO<sub>2</sub> from the exhaust of gas turbine combined-cycle plants, however, can be difficult for several reasons. For instance, there is typically a low concentration of CO<sub>2</sub> in the exhaust compared to the large volume of gas that must be treated. Also, additional cooling is often required before introducing the exhaust to a CO<sub>2</sub> capture system and the exhaust can become saturated with water after cooling, thereby increasing the reboiler duty in the CO<sub>2</sub> capture system. Other common factors can include the low pressure and large quantities of oxygen frequently contained in the exhaust. All of these factors result in a high cost of CO<sub>2</sub> capture from gas turbine combined-cycle power plants.

[0007] Some approaches to lower CO<sub>2</sub> emissions include fuel de-carbonization or post-combustion capture using solvents, such as amines. However, both of these solutions are expensive and reduce power generation efficiency, resulting in lower power production, increased fuel demand and increased cost of electricity to meet domestic power demand. In particular, the presence of oxygen, SO<sub>x</sub>, and NO<sub>x</sub> components makes the use of amine solvent absorption very problematic. Another approach is an oxyfuel gas turbine in a combined cycle (e.g. where exhaust heat from the gas turbine Brayton cycle is captured to make steam and produce additional power in a Rankin cycle). However, there are no commercially available gas turbines that can operate in such a cycle and the power required to produce high purity oxygen significantly reduces the overall efficiency of the process. Several studies have compared these processes and show some of the advantages of each approach. See, e.g. BOLLAND, OLAV, and UNDRUM, HENRIETTE, *Removal of CO<sub>2</sub> from Gas Turbine Power Plants: Evaluation of pre- and post-combustion methods*, SINTEF Group, found at <http://www.energy.sintef.no/publ/xergi/98/3/3art-8-engelsk.htm> (1998).

[0008] Other approaches to lower CO<sub>2</sub> emissions include stoichiometric exhaust gas recirculation, such as in natural gas combined cycles (NGCC). In a conventional NGCC system, only about 40% of the air intake volume is required to provide adequate stoichiometric combustion of the fuel, while the remaining 60% of the air volume serves to moderate the temperature and cool the exhaust gas so as to be suitable for introduction into the succeeding expander, but also disadvantageously generate an excess oxygen byproduct which is difficult to remove. The typical NGCC produces low pressure exhaust gas which requires a fraction of the power produced to extract the CO<sub>2</sub> for sequestration or EOR, thereby reducing the thermal efficiency of the NGCC. Further, the equipment for the CO<sub>2</sub> extraction is large and expensive, and several stages of compression are required to take the

ambient pressure gas to the pressure required for EOR or sequestration. Such limitations are typical of post-combustion carbon capture from low pressure exhaust gas associated with the combustion of other fossil fuels, such as coal.

5 [0009] The capacity and efficiency of the exhaust gas compressor in a combined-cycle power generating plant is directly affected by the inlet temperature and composition of the recycled exhaust gas. Conventionally, the exhaust gas is cooled by direct contact with recycled water in a direct contact cooler. The recycled water may be cooled by several methods, including using a heat exchanger to reject heat to the recirculated cooling water, using an air-fin  
10 heat exchanger, or by evaporative cooling with a conventional cooling tower. Cooling by these methods, however, is limited by the ambient air conditions, especially in warmer climates.

[0010] The foregoing discussion of need in the art is intended to be representative rather than exhaustive. A technology addressing one or more  
15 such needs, or some other related shortcoming in the field, would benefit power generation in combined-cycle power systems.

#### **SUMMARY OF THE INVENTION**

[0011] The present disclosure is directed to integrated systems and methods for improving power generation systems. In some implementations, the present  
20 disclosure provides an integrated system comprising a gas turbine system, an exhaust gas recirculation system, and a CO<sub>2</sub> separator advantageously integrated. The gas turbine system may have a combustion chamber configured to stoichiometrically combust a compressed oxidant and a fuel in the presence of a compressed recycle exhaust gas. The compressed recycle exhaust gas serves  
25 to moderate a temperature of combustion in the combustion chamber. The combustion chamber directs a discharge to an expander configured to generate a gaseous exhaust stream and at least partially drive a main compressor. The gaseous exhaust stream from the expander is directed to an exhaust gas recirculation system having at least one cooling unit which may be an integrated  
30 cooling unit. The at least one cooling unit cools the gaseous exhaust before injection into the main compressor to generate the compressed recycle exhaust gas. The CO<sub>2</sub> separator is fluidly coupled to the compressed recycle exhaust gas via a purge stream and is configured to discharge a residual stream consisting

primarily of nitrogen-rich gas. The nitrogen-rich gas may be expanded in a gas expander to generate a nitrogen exhaust gas. The nitrogen exhaust gas is injected into the at least one cooling unit to cool the gaseous exhaust. The at least one cooling unit is integrated in that at least some of the cooling effect is enhanced by the integrated use of the nitrogen exhaust gas.

**[0011a]** According to one aspect of the present invention, there is provided An integrated system, comprising:

a gas turbine system having a combustion chamber configured to substantially stoichiometrically combust a compressed oxidant and a fuel in the presence of a compressed recycle exhaust gas, wherein the compressed recycle exhaust gas moderates a temperature of combustion in the combustion chamber, and the combustion chamber directs a discharge to an expander configured to generate a gaseous exhaust stream and at least partially drive a main compressor;

an exhaust gas recirculation system having at least one cooling unit, wherein the at least one cooling unit cools the gaseous exhaust before injection into the main compressor to generate the compressed recycle exhaust gas

a CO<sub>2</sub> separator fluidly coupled to the compressed recycle exhaust gas via a purge stream and configured to discharge a residual stream consisting primarily of nitrogen gas to be expanded in a gas expander and generate a nitrogen exhaust gas, wherein the nitrogen exhaust gas is injected into the at least one cooling unit to cool the gaseous exhaust stream; and

a residual cooling unit fluidly coupled to the residual stream and configured to reduce the temperature of the residual stream and extract condensed water therefrom;

wherein the at least one cooling unit is an evaporative cooling unit comprising:

a first column configured to receive the nitrogen exhaust gas and a cool water supply, wherein the nitrogen exhaust gas evaporates a portion of the cool water supply to cool the cool water supply and generate a cooled water

discharge, and

a second column configured to receive the cooled water discharge and the gaseous exhaust, wherein interaction between the cooled water discharge and the gaseous exhaust stream cools the gaseous exhaust stream.



**[0012]** Additionally or alternatively, the present disclosure provides methods of generating power. Exemplary methods include: a) stoichiometrically combusting a compressed oxidant and a fuel in a combustion chamber and in the presence of a compressed recycle exhaust gas, thereby generating a discharge stream, wherein the compressed recycle exhaust gas acts as a diluent configured to moderate the temperature of the discharge stream; b) expanding the discharge stream in an expander to at least partially drive a main compressor and generate a gaseous exhaust stream; c) directing the gaseous exhaust stream into at least one integrated cooling unit; d) cooling the gaseous exhaust stream in the at least one integrated cooling unit before injecting the gaseous exhaust stream into the main compressor to generate the compressed recycle exhaust gas; e) directing a portion of the compressed recycle exhaust gas to a CO<sub>2</sub> separator via a purge stream, the CO<sub>2</sub> separator being configured to discharge a residual stream consisting primarily of nitrogen-rich gas to be expanded in a gas expander and generate a nitrogen exhaust gas; and f) injecting the nitrogen exhaust gas into the at least one integrated cooling unit to cool the gaseous exhaust stream.

**[0012a]** According to one aspect, the method of generating power comprises substantially stoichiometrically combusting a compressed oxidant and a fuel in a combustion chamber and in the presence of a compressed recycle exhaust gas, thereby generating a discharge stream, wherein the compressed recycle exhaust gas acts as a diluent configured to moderate the temperature of the discharge stream;

expanding the discharge stream in an expander to at least partially drive a main compressor and generate a gaseous exhaust stream;

directing the gaseous exhaust stream into at least one cooling unit;

cooling the gaseous exhaust stream in the at least one cooling unit before injecting the gaseous exhaust stream into the main compressor to generate the compressed recycle exhaust gas;

directing a portion of the compressed recycle exhaust gas to a CO<sub>2</sub> separator via a purge stream, the CO<sub>2</sub> separator being configured to discharge a

residual stream consisting primarily of nitrogen- gas to be expanded in a gas expander and generate a nitrogen exhaust gas;

cooling the residual stream with a residual cooling unit fluidly coupled to the CO<sub>2</sub> separator ;

extracting condensed water from the residual stream; and

injecting the nitrogen exhaust gas into the at least one cooling unit to cool the gaseous exhaust stream,

wherein the at least one cooling unit is an evaporative cooling unit comprising:

a first column configured to receive the nitrogen exhaust gas and a cool water supply, wherein the nitrogen exhaust gas evaporates a portion of the cool water supply to cool the cool water supply and generate a cooled water discharge, and

a second column configured to receive the cooled water discharge and the gaseous exhaust, wherein interaction between the cooled water discharge and the gaseous exhaust stream cools the gaseous exhaust stream.

**[0013]** Still additionally or alternatively, the present systems may include a combustion chamber, an evaporative cooling tower, and a CO<sub>2</sub> separator. The combustion chamber may be configured to stoichiometrically combust a compressed oxidant and a fuel in the presence of a compressed recycle exhaust gas. The combustion chamber directs a discharge to an expander configured to generate a gaseous exhaust stream and drive a main compressor. The evaporative cooling tower may have a first column and a second column. The second column may be configured to receive and cool the gaseous exhaust stream before being compressed in the main compressor to generate the compressed recycle exhaust gas. The CO<sub>2</sub> separator may be fluidly coupled to the compressed recycle exhaust gas via a purge stream and configured to discharge a residual stream consisting primarily of nitrogen-rich gas to be

expanded in a gas expander and generate a nitrogen exhaust gas, wherein the nitrogen exhaust gas is injected into the first column to evaporate and cool a cooling water supply to discharge a cooled water, and wherein the cooled water is injected into the second column to cool the gaseous exhaust stream.

**[0013a]** According to a further aspect of the present invention, there is provided a combined-cycle power generation system, comprising:

a combustion chamber configured to substantially stoichiometrically combust a compressed oxidant and a fuel in the presence of a compressed recycle exhaust gas, wherein the combustion chamber directs a discharge to an expander configured to generate a gaseous exhaust stream and drive a main compressor;

an evaporative cooling tower having a first column and a second column, wherein the second column is configured to receive and cool the gaseous exhaust stream before being compressed in the main compressor to generate the compressed recycle exhaust gas; and

a condenser fluidly coupled to the residual stream and configured to reduce the temperature of the residual stream and extract condensed water therefrom.

a CO<sub>2</sub> separator fluidly coupled to the compressed recycle exhaust gas via a purge stream and configured to discharge a residual stream consisting primarily of nitrogen gas to be expanded in a gas expander and generate a nitrogen exhaust gas, wherein the nitrogen exhaust gas is injected into the first column to evaporate and cool a cooling water supply to discharge a cooled water, and wherein the cooled water is injected into the second column to cool the gaseous exhaust stream.

#### **BRIEF DESCRIPTION OF THE DRAWINGS**

**[0014]** The foregoing and other advantages of the present disclosure may become apparent upon reviewing the following detailed description and drawings of non-limiting examples of embodiments in which:

[0015] FIG. 1 depicts an illustrative integrated system for low emission power generation and enhanced CO<sub>2</sub> recovery, according to one or more embodiments of the present disclosure.

[0016] FIG. 2 depicts an illustrative cooling unit for cooling exhaust gas prior to being compressed, according to one or more embodiments of the present disclosure.

#### DETAILED DESCRIPTION

[0017] In the following detailed description section, the specific embodiments of the present disclosure are described in connection with preferred embodiments. However, to the extent that the following description is specific to a particular embodiment or a particular use of the present disclosure, this is intended to be for exemplary purposes only and simply provides a description of the exemplary embodiments. Accordingly, the disclosure is not limited to the specific embodiments described below, but rather, it includes all alternatives, modifications, and equivalents falling within the true spirit and scope of the appended claims.

[0018] Various terms as used herein are defined below. To the extent a term used in a claim is not defined below, it should be given the broadest definition persons in the pertinent art have given that term as reflected in at least one printed publication or issued patent.

[0019] As used herein, the term "stoichiometric combustion" refers to a combustion reaction having a volume of reactants comprising a fuel and an oxidizer and a volume of products formed by combusting the reactants where the entire volume of the reactants is used to form the products. As used herein, the term "substantially stoichiometric combustion" refers to a combustion reaction having a molar ratio of combustion fuel to oxygen ranging from about plus or minus 10% of the oxygen required for a stoichiometric ratio or more preferably from about plus or minus 5% of the oxygen required for the stoichiometric ratio. For example, the stoichiometric ratio of fuel to oxygen for methane is 1:2 ( $CH_4 + 2O_2 > CO_2 + 2H_2O$ ). Propane will have a stoichiometric ratio of fuel to oxygen of 1:5. Another way of measuring substantially stoichiometric combustion is as a ratio of oxygen supplied to oxygen required for stoichiometric combustion, such as from about 0.9:1 to about 1.1:1, or more preferably from about 0.95:1 to about 1.05:1.

[0020] As used herein, the term "stream" refers to a volume of fluids, although use of the term stream typically means a moving volume of fluids (*e.g.*, having a velocity or mass flow rate). The term "stream," however, does not require a velocity, mass flow rate, or a particular type of conduit for enclosing the stream.

[0021] Embodiments of the presently disclosed systems and processes can be used to produce ultra low emission electric power and CO<sub>2</sub> for enhanced oil recovery (EOR) and/or sequestration applications. In one or more embodiments, a mixture of air and fuel can be stoichiometrically or substantially stoichiometrically combusted and mixed with a stream of recycled exhaust gas. The stream of recycled exhaust gas, generally including products of combustion such as CO<sub>2</sub>, can be used as a diluent to control, adjust, or otherwise moderate the temperature of combustion and the exhaust that enters the succeeding expander. As a result of using enriched air, the recycled exhaust gas can have an increased CO<sub>2</sub> content, thereby allowing the expander to operate at even higher expansion ratios for the same inlet and discharge temperatures, thereby producing significantly increased power.

[0022] Combustion in commercial gas turbines at stoichiometric conditions or substantially stoichiometric conditions (e.g., "slightly rich" combustion) can prove advantageous in order to eliminate the cost of excess oxygen removal. Still further, slightly lean combustion may further reduce the oxygen content in the exhaust stream. By cooling the exhaust and condensing the water out of the cooled exhaust stream, a relatively high content CO<sub>2</sub> exhaust stream can be produced. While a portion of the recycled exhaust gas can be utilized for temperature moderation in the closed Brayton cycle, a remaining purge stream can be used for EOR applications and/or electric power can be produced with little or no sulfur oxides (SO<sub>x</sub>), nitrogen oxides (NO<sub>x</sub>), and/or CO<sub>2</sub> being emitted to the atmosphere. When the purge stream, or a portion thereof, is routed for electric power production, the result is the production of power in three separate cycles and the manufacturing of additional CO<sub>2</sub>.

[0023] Because the capacity and efficiency of an exhaust gas compressor is directly affected by the inlet temperature of the recycled exhaust gas, it can prove advantageous to lower the temperature of the recycled exhaust gas prior to compression. Accordingly, embodiments of the disclosure use a nitrogen vent stream having a low relative humidity as an evaporative cooling media in a cooling unit preceding the exhaust gas compressor. The dry nitrogen gas can be configured to evaporate and cool a stream of water adapted to cool the recirculating exhaust gas, thereby injecting a colder exhaust gas into the compressor and increasing its efficiency by allowing added capacity thereto. As can be appreciated, this may prove advantageous for several reasons. For instance, a lower suction temperature can equate to a lower discharge temperature, which can reduce the cooling required for low-energy CO<sub>2</sub> separation processes. Moreover, the additional cooling unit can remove an additional amount

of water from the recycled exhaust gas, thereby reducing reboiler duties in any the CO<sub>2</sub> separation system.

[0024] Referring now to the figures, FIG. 1 depicts a schematic of an illustrative integrated system **100** for power generation and CO<sub>2</sub> recovery using a combined-cycle arrangement, according to one or more embodiments. In at least one embodiment, the power generation system **100** can include a gas turbine system **102** characterized as a power-producing closed Brayton cycle. The gas turbine system **102** can have a first or main compressor **104** coupled to an expander **106** through a common shaft **108** or other mechanical, electrical, or other power coupling, thereby allowing a portion of the mechanical energy generated by the expander **106** to drive the main compressor **104**. The gas turbine system **102** can be a standard gas turbine, where the main compressor **104** and expander **106** form the compressor and expander ends, respectively. In other embodiments, however, the main compressor **104** and expander **106** can be individualized components in the system **102**.

[0025] The gas turbine system **102** can also include a combustion chamber **110** configured to combust a fuel introduced via line **112** mixed with a compressed oxidant in line **114**. In one or more embodiments, the fuel in line **112** can include any suitable hydrocarbon gas or liquid, such as natural gas, methane, ethane, naphtha, butane, propane, syngas, diesel, kerosene, aviation fuel, coal derived fuel, bio-fuel, oxygenated hydrocarbon feedstock, or any combination thereof. The compressed oxidant in line **114** can be derived from a second or inlet compressor **118** fluidly coupled to the combustion chamber **110** and adapted to compress a feed oxidant introduced via line **120**. In one or more embodiments, the feed oxidant in line **120** can include any suitable gas containing oxygen, such as air, oxygen-rich air, oxygen-depleted air, pure oxygen, or combinations thereof.

[0026] As will be described in more detail below, the combustion chamber **110** can also receive a compressed recycle exhaust gas in line **144**, including an exhaust gas recirculation primarily having CO<sub>2</sub> and nitrogen components. The compressed recycle exhaust gas in line **144** can be derived from the main compressor **104** and adapted to help facilitate a stoichiometric or substantially stoichiometric combustion of the compressed oxidant in line **114** and fuel in line **112** by moderating the temperature of the combustion products. As can be appreciated, recirculating the exhaust gas can serve to increase the CO<sub>2</sub> concentration in the exhaust gas.

[0027] An exhaust gas in line **116** directed to the inlet of the expander **106** can be generated as a product of combustion of the fuel in line **112** and the compressed oxidant in line **114**, in the presence of the compressed recycle exhaust gas in line **144**. In at least one

embodiment, the fuel in line **112** can be primarily natural gas, thereby generating a discharge or exhaust gas via line **116** that can include volumetric portions of vaporized water, CO<sub>2</sub>, nitrogen, nitrogen oxides (NO<sub>x</sub>), and sulfur oxides (SO<sub>x</sub>). In some embodiments, a small portion of unburned fuel in line **112** or other compounds can also be present in the exhaust gas in line **116** due to combustion equilibrium limitations. As the exhaust gas in line **116** expands through the expander **106** it generates mechanical power to drive the main compressor **104**, an electrical generator, or other facilities, and also produces a gaseous exhaust stream **122** having a heightened CO<sub>2</sub> content resulting from the influx of the compressed recycle exhaust gas in line **144**. The expander **106** may generate power for uses in addition to or as alternatives to the main compressor **104**. For example, the expander **106** may produce electricity.

[0028] The power generation system **100** can also include an exhaust gas recirculation (EGR) system **124**. In one or more embodiments, the EGR system **124** can include a heat recovery steam generator (HRSG) **126**, or similar device, fluidly coupled to a steam gas turbine **128**. In at least one embodiment, the combination of the HRSG **126** and the steam gas turbine **128** can be characterized as a power-producing closed Rankine cycle. In combination with the gas turbine system **102**, the HRSG **126** and the steam gas turbine **128** can form part of a combined-cycle power generating plant, such as a natural gas combined-cycle (NGCC) plant. The gaseous exhaust stream **122** can be introduced to the HRSG **126** in order to generate steam via line **130** and a cooled exhaust gas in line **132**. In one embodiment, the steam in line **130** can be sent to the steam gas turbine **128** to generate additional electrical power.

[0029] The cooled exhaust gas in line **132** can be sent to any variety of apparatus and/or facilities in a recycle loop back to the main compressor **104**. In some implementations, and as shown in FIG. 1, the recycle loop may comprise a first cooling unit **134** adapted to cool the cooled exhaust gas in line **132** and to generate a cooled recycle gas stream **140**. The first cooling unit **134** can include, for example, one or more contact coolers, trim coolers, evaporative cooling unit, or any combination thereof. The first cooling unit **134** can also be adapted to remove a portion of any condensed water from the cooled exhaust gas in line **132** via a water dropout stream **138**. In at least one embodiment, the water dropout stream **138** may be routed to the HRSG **126** via line **141** to provide a water source for the generation of additional steam in line **130** therein. In other embodiments, the water recovered via the water dropout stream **138** can be used for other downstream applications, such as supplementary heat exchanging processes.

[0030] In one or more embodiments, the cooled recycle gas stream **140** can be directed to a boost compressor **142**. Cooling the cooled exhaust gas in line **132** in the first cooling unit **134** can reduce the power required to compress the cooled recycle gas stream **140** in the boost compressor **142**. As opposed to a conventional fan or blower system, the boost compressor **142** can be configured to compress and increase the overall density of the cooled recycle gas stream **140**, thereby directing a pressurized recycle gas in line **145** downstream, where the pressurized recycle gas in line **145** has an increased mass flow rate for the same volumetric flow. This can prove advantageous since the main compressor **104** can be volume-flow limited, and directing more mass flow through the main compressor **104** can result in higher discharge pressures, thereby translating into higher pressure ratios across the expander **106**. Higher pressure ratios generated across the expander **106** can allow for higher inlet temperatures and, therefore, an increase in expander **106** power and efficiency. As can be appreciated, this may prove advantageous since the CO<sub>2</sub>-rich exhaust gas in line **116** generally maintains a higher specific heat capacity.

[0031] Since the suction pressure of the main compressor **104** is a function of its suction temperature, a cooler suction temperature will demand less power to operate the main compressor **104** for the same mass flow. Consequently, the pressurized recycle gas in line **145** can optionally be directed to a second cooling unit **136**. The second cooling unit **136** can include, for example, one or more direct contact coolers, trim coolers, evaporative cooling units, or any combination thereof. In at least one embodiment, the second cooling unit **136** can serve as an after-cooler adapted to remove at least a portion of the heat of compression generated by the boost compressor **142** on the pressurized recycle gas in line **145**. The second cooling unit **136** can also extract additional condensed water via a water dropout stream **143**. In one or more embodiments, the water dropout streams **138**, **143** can converge into stream **141** and may or may not be routed to the HRSG **126** to generate additional steam via line **130** therein. After undergoing cooling in the second cooling unit **136**, the pressurized recycle gas in line **145** can be directed to a third cooling unit **200**. While only first, second, and third cooling units **134**, **136**, **200** are depicted herein, it will be appreciated that any number of cooling units can be employed to suit a variety of applications, without departing from the scope of the disclosure. For example, a single cooling unit may be implemented in some embodiments.

[0032] As will be described in more detail below, the third cooling unit **200**, like the first and second cooling units, can be an evaporative cooling unit configured to further reduce the temperature of the pressurized recycle gas in line **145** before being injected into the main



compressor **104** via stream **214**. In other embodiments, however, one or more of the cooling units **134**, **236**, **200** can be a mechanical refrigeration system without departing from the scope of the disclosure. The main compressor **104** can be configured to compress the pressurized recycle gas in line **214** received from the third cooling unit **200** to a pressure  
5 nominally at or above the combustion chamber pressure, thereby generating the compressed recycle gas in line **144**. As can be appreciated, cooling the pressurized recycle gas in line **145** in both the second and third cooling units **136**, **200** after compression in the boost compressor **142** can allow for an increased volumetric mass flow of exhaust gas into the main compressor **104**. Consequently, this can reduce the amount of power required to compress the  
10 pressurized recycle gas in line **145** to a predetermined pressure.

[**0033**] While FIG. 1 illustrates three cooling units and a boost compressor in the exhaust gas recirculation loop, it should be understood that each of these units is adapted to reduce the mass flow rate in the cooled exhaust gas in line **132**. As described above, a reduction in mass flow rate, such as by the boost compressor, together with a reduction in temperature is  
15 advantageous. The present disclosure is directed to an integration within the power generation system **100** to enhance the cooling of the exhaust gas in the exhaust gas recirculation loop, which in some implementations may simplify the exhaust gas recirculation loop to a single cooling unit between the HSRG system **126** and the main compressor **104**, as will be described further herein.

[**0034**] In at least one embodiment, a purge stream **146** can be recovered from the compressed recycle gas in line **144** and subsequently treated in a CO<sub>2</sub> separator **148** to capture CO<sub>2</sub> at an elevated pressure via line **150**. The separated CO<sub>2</sub> in line **150** can be used for sales, used in another processes requiring CO<sub>2</sub>, and/or further compressed and injected into a terrestrial reservoir for enhanced oil recovery (EOR), sequestration, or another purpose.  
25 Because of the stoichiometric or substantially stoichiometric combustion of the fuel in line **112** combined with the apparatus on the exhaust gas recirculation system **124**, the CO<sub>2</sub> partial pressure in the purge stream **146** can be much higher than in conventional gas turbine exhausts. As a result, carbon capture in the CO<sub>2</sub> separator **148** can be undertaken using low-energy separation processes, such as less energy-intensive solvents. At least one suitable  
30 solvent is potassium carbonate (K<sub>2</sub>CO<sub>3</sub>) which absorbs SO<sub>x</sub> and/or NO<sub>x</sub>, and converts them to useful compounds, such as potassium sulfite (K<sub>2</sub>SO<sub>3</sub>), potassium nitrate (KNO<sub>3</sub>), and other simple fertilizers. Exemplary systems and methods of using potassium carbonate for CO<sub>2</sub> capture can be found in the concurrently filed U.S. Patent Application entitled "Low

Emission Triple-Cycle Power Generation Systems and Methods," the contents of which are hereby incorporated by reference to the extent not inconsistent with the present disclosure.

[0035] A residual stream **151**, essentially depleted of CO<sub>2</sub> and consisting primarily of nitrogen, can also be derived from the CO<sub>2</sub> separator **148**. In one or more embodiments, the residual stream **151** can be introduced to a gas expander **152** to provide power and an expanded depressurized gas via line **156**. The expander **152** can be, for example, a power-producing nitrogen expander. As depicted, the gas expander **152** can be optionally coupled to the inlet compressor **118** through a common shaft **154** or other mechanical, electrical, or other power coupling, thereby allowing a portion of the power generated by the gas expander **152** to drive the inlet compressor **118**. In other embodiments, however, the gas expander **152** can be used to provide power to other applications, and not directly coupled to the stoichiometric compressor **118**. For example, there may be a substantial mismatch between the power generated by the expander **152** and the requirements of the compressor **118**. In such cases, the expander **152** could be adapted to drive a smaller compressor (not shown) that demands less power. Alternatively, the expander could be adapted to drive a larger compressor demanding more power.

[0036] An expanded depressurized gas in line **156**, primarily consisting of dry nitrogen gas, can be discharged from the gas expander **152**. As will be described in more detail below, the resultant dry nitrogen can help facilitate the evaporation and cooling of a stream of water in the third cooling unit **200** to thereby cool the pressurized recycle gas in line **145**. In at least one embodiment, the combination of the gas expander **152**, inlet compressor **118**, and CO<sub>2</sub> separator can be characterized as an open Brayton cycle, or a third power-producing component of the system **100**.

[0037] The power generation system **100** as described herein, particularly with the added exhaust gas exhaust pressurization from the boost compressor **142**, can be implemented to achieve a higher concentration of CO<sub>2</sub> in the exhaust gas, thereby allowing for more effective CO<sub>2</sub> separation and capture. For instance, embodiments disclosed herein can effectively increase the concentration of CO<sub>2</sub> in the exhaust gas exhaust stream to about 10vol% with a pure methane fuel or even higher with a richer gas. To accomplish this, the combustion chamber **110** can be adapted to stoichiometrically combust the incoming mixture of fuel in line **112** and compressed oxidant in line **114**. In order to moderate the temperature of the stoichiometric combustion to meet expander **106** inlet temperature and component cooling requirements, a portion of the exhaust gas derived from the compressed recycle gas in line **144** can be injected into the combustion chamber **110** as a diluent. As compared to the

conventional practice of introducing excess air or oxidant in the combustion chamber to moderate temperature, the use of the recycled exhaust gas significantly reduces the amount of oxygen exiting the combustion chamber **110**. Thus, embodiments of the disclosure can essentially eliminate any excess oxygen from the exhaust gas while simultaneously  
5 increasing its CO<sub>2</sub> composition. As such, the gaseous exhaust stream **122** can have less than about 3.0 vol% oxygen, or less than about 1.0 vol% oxygen, or less than about 0.1 vol% oxygen, or even less than about 0.001 vol% oxygen.

[0038] The specifics of exemplary operation of the system **100** will now be discussed. As will be appreciated, specific temperatures and pressures achieved or experienced in the  
10 various components of any of the embodiments disclosed herein can change depending on, among other factors, the purity of the oxidant used and/or the specific makes and/or models of expanders, compressors, coolers, etc. Accordingly, it will be appreciated that the particular data described herein is for illustrative purposes only and should not be construed as the only interpretation thereof. For example, in one embodiment described herein, the  
15 inlet compressor **118** can be configured to provide compressed oxidant in line **114** at pressures ranging between about 280 psia and about 300 psia. Also contemplated herein, however, is aeroderivative gas turbine technology, which can produce and consume pressures of up to about 750 psia and more.

[0039] The main compressor **104** can be configured to recycle and compress recycled  
20 exhaust gas into the compressed recycle gas in line **144** at a pressure nominally above or at the combustion chamber **110** pressure, and use a portion of that recycled exhaust gas as a diluent in the combustion chamber **110**. Because amounts of diluent needed in the combustion chamber **110** can depend on the purity of the oxidant used for stoichiometric combustion or the particular model or design of expander **106**, a ring of thermocouples and/or  
25 oxygen sensors (not shown) can be disposed associated with the combustion chamber and/or the expander. For example, thermocouples and/or oxygen sensors may be disposed on the outlet of the combustion chamber **110**, on the inlet to the expander **106** and/or on the outlet of the expander **106**. In operation, the thermocouples and sensors can be adapted to determine the compositions and/or temperatures of one or more streams for use in determining the  
30 volume of exhaust gas required as diluent to cool the products of combustion to the required expander inlet temperature. Additionally or alternatively, the thermocouples and sensors may be adapted to determine the amount of oxidant to be injected into the combustion chamber **110**. Thus, in response to the heat requirements detected by the thermocouples and the oxygen levels detected by the oxygen sensors, the volumetric mass flow of compressed

recycle gas in line **144** and/or compressed oxidant in line **114** can be manipulated or controlled to match the demand. The volumetric mass flow rates may be controlled through any suitable flow control systems, which may be in electrical communication with the thermocouples and/or oxygen sensors.

5 [0040] In at least one embodiment, a pressure drop of about 12-13 psia can be experienced across the combustion chamber **110** during stoichiometric or substantially stoichiometric combustion. Combustion of the fuel in line **112** and the compressed oxidant in line **114** can generate temperatures between about 2000 °F and about 3000 °F and pressures ranging from 250 psia to about 300 psia. Because of the increased mass flow and higher  
10 specific heat capacity of the CO<sub>2</sub>-rich exhaust gas derived from the compressed recycle gas in line **144**, a higher pressure ratio can be achieved across the expander **106**, thereby allowing for higher inlet temperatures and increased expander **106** power.

[0041] The gaseous exhaust stream **122** exiting the expander **106** can exhibit pressures at or near ambient. In at least one embodiment, the gaseous exhaust stream **122** can have a  
15 pressure of about 13-17 psia. The temperature of the gaseous exhaust stream **122** can be about 1225 °F to about 1275 °F before passing through the HRSG **126** to generate steam in line **130** and a cooled exhaust gas in line **132**.

[0042] The next several paragraphs describe the exemplary implementation shown in FIG. 1. As described above, FIG. 1 illustrates multiple apparatuses in association with the  
20 exhaust gas recycle loop in the interest of illustrating the various possible combinations. However, it should be understood that the invention described herein does not require a combination of all such elements and is defined by the following claims and/or the claims of any subsequent applications claiming priority to this application. For example, while multiple cooling units are illustrated in FIG. 1, it should be understood that a direct contact  
25 cooling unit utilizing coolant associated with the nitrogen vent stream (described as cooling unit **200** below) may provide sufficient cooling by virtue of the single cooling unit. In some implementations, the cooling unit **200** may provide sufficient cooling to provide the advantages of the booster compressor as well.

[0043] Continuing with the discussion of the exemplary implementation of FIG.1, in one  
30 or more embodiments, the cooling unit **134** can reduce the temperature of the cooled exhaust gas in line **132** thereby generating the cooled recycle gas stream **140** having a temperature between about 32 °F and about 120 °F. As can be appreciated, such temperatures can fluctuate depending primarily on wet bulb temperatures during specific seasons in specific locations around the globe.

[0044] According to one or more embodiments, the boost compressor **142** can be configured to elevate the pressure of the cooled recycle gas stream **140** to a pressure ranging from about 17 psia to about 21 psia. The added compression of the boost compressor is an additional method, in addition to the use of cooling units, to provide a recycled exhaust gas to  
5 the main compressor **104** having a higher density and increased mass flow, thereby allowing for a substantially higher discharge pressure while maintaining the same or similar pressure ratio. In order to further increase the density and mass flow of the exhaust gas, the pressurized recycle gas in line **145** discharged from the boost compressor **142** can then be further cooled in the second and third cooling units **136, 200**. In one or more embodiments,  
10 the second cooling unit **136** can be configured to reduce the temperature of the pressurized recycle gas in line **145** to about 105 °F before being directed to the third cooling unit **200**. As will be discussed in more detail below, the third cooling unit **200** can be configured to reduce the temperature of the pressurized recycle gas in line **145** to temperatures below about 100 °F.

[0045] In at least one embodiment, the temperature of the compressed recycle gas in line **144** discharged from the main compressor **104** and the purge stream **146** can be about 800 °F, with a pressure of around 280 psia. As can be appreciated, the addition of the boost compressor **142** and/or the one or more cooling units can increase the CO<sub>2</sub> purge pressure in the purge stream line **146**, which can lead to improved solvent treating performance in the  
20 CO<sub>2</sub> separator **148** due to the higher CO<sub>2</sub> partial pressure. In one embodiment, the gas treating processes in the CO<sub>2</sub> separator **148** can require the temperature of the purge stream **146** to be cooled to about 250 °F – 300 °F. To achieve this, the purge stream **146** can be channeled through a heat exchanger **158**, such as a cross-exchange heat exchanger. Extracting CO<sub>2</sub> from the purge stream **146** in the CO<sub>2</sub> separator **148** can leave a saturated,  
25 nitrogen-rich residual stream **151** at or near the elevated pressure of the purge stream **146** and at a temperature of about 150 °F. The heat exchanger **158** may be coupled with the residual stream **151** as illustrated or with other streams or facilities in the integrated system. When coupled with the residual stream **151**, the residual stream may be heated to increase the power obtainable from the gas expander **152**.

[0046] As stated above, the nitrogen in the residual stream **151** as subsequently expanded into expanded depressurized gas in line **156** can be subsequently used to evaporate and cool water configured to cool the pressurized recycle gas in line **145** injected into the third cooling unit **200**, which may be the only cooling unit in the exhaust gas recycle loop. As an evaporative cooling catalyst, the nitrogen should be as dry as possible. Accordingly, the

residual stream **151** can be directed through a fourth cooling unit **160** or condenser configured to cool the residual stream **151**, thereby condensing and extracting an additional portion of water via line **162**. In one or more embodiments, the fourth cooling unit **160** can be a direct contact cooler cooled with standard cooling water in order to reduce the temperature of the residual stream **151** to about 105 °F. In other embodiments, the fourth cooling unit **160** can be a trim cooler or straight heat exchanger. The resultant water content of the residual stream **151** can be at about 0.1wt% to about 0.5wt%. In one embodiment, the water removed via stream **162** can be routed to the HRSG **126** to create additional steam. In other embodiments, the water in stream **162** can be treated and used as agricultural water or demineralized water.

[0047] A dry nitrogen gas can be discharged from the fourth cooling unit **160** via stream **164**. In one embodiment, the heat energy associated with cooling the purge stream **146** is extracted via the heat exchanger **158**, which can be fluidly coupled to the dry nitrogen gas stream **164** and configured to re-heat the nitrogen gas prior to expansion. Reheating the nitrogen gas can generate a dry heated nitrogen stream **166** having a temperature ranging from about 750 °F to about 790 °F, and a pressure of around 270-280 psia. In embodiments where the heat exchanger **158** is a gas/gas heat exchanger, there will be a "pinch point" temperature difference realized between the purge stream **146** and the dry nitrogen gas stream **164**, wherein the dry nitrogen gas stream **164** is generally around 25 °F less than the temperature of the purge stream **146**.

[0048] In one or more embodiments, the dry heated nitrogen stream **166** can then be expanded through the gas expander **152** and optionally power the stoichiometric inlet compressor **118**, as described above. Accordingly, cross-exchanging the heat in the heat exchanger **158** can be configured to capture a substantial amount of compression energy derived from the main compressor **104** and use it to maximize the power extracted from the gas expander **152**. In at least one embodiment, the gas expander **152** discharges a nitrogen expanded depressurized gas in line **156** at or near atmospheric pressure and having a temperature ranging from about 100 °F to about 105 °F. As can be appreciated, the resulting temperature of the nitrogen expanded depressurized gas in line **156** can generally be a function of the composition of the exhaust gas, the temperature purge gas **146**, and the pressure of the dry nitrogen gas stream **164** before being expanded in the gas expander **152**.

[0049] Since a measurable amount of water can be removed from the residual stream **151** in the fourth cooling unit **160**, a decreased amount of mass flow will be subsequently expanded in the gas expander **152**, thereby resulting in reduced power production.

Consequently, during start-up of the system **100** and during normal operation when the gas expander **152** is unable to supply all the required power to operate the inlet compressor **118**, at least one motor **168**, such as an electric motor, can be used synergistically with the gas expander **152**. For instance, the motor **168** can be sensibly sized such that during normal operation of the system **400**, the motor **168** can be configured to supply the power short-fall from the gas expander **152**. Additionally or alternatively, the motor **168** may be configured as a motor/generator to be convertible to a generator when the gas turbine **152** produces more power than needed by the inlet compressor **118**.

[0050] Illustrative systems and methods of expanding the nitrogen gas in the residual stream **151**, and variations thereof, can be found in the concurrently filed U.S. Patent Application entitled "Low Emission Triple-Cycle Power Generation Systems and Methods," the contents of which are hereby incorporated by reference to the extent not inconsistent with the present disclosure.

[0051] Referring now to FIG. 2, depicted is a schematic view of the third cooling unit **200**, as illustrated in FIG. 1. As discussed above, the illustrated third cooling unit **200** may be the only unit provided in the exhaust gas recycle loop. Additionally or alternatively, the third cooling unit **200** and other pieces of equipment, such as one or more of those illustrated in FIG. 1, may be configured in any suitable arrangement such that the third cooling unit **200** is actually first (or second, etc.) in the order rather than third. Accordingly, it should be understood that the ordinal designation of "third" is with reference to specific implementation of FIG. 1 and it is not required that the features of cooling unit **200** of FIG. 2 be implemented as the third cooling unit in a system, but may be disposed in any suitable position in the exhaust gas recycle loop.

[0052] In one or more embodiments, the cooling unit **200** can include a first column **202** fluidly coupled to a second column **204**. In one or more embodiments, the first column **202** can be an evaporative cooling tower and the second column **204** can be a direct contact cooling tower. The first column **202** can be configured to receive the nitrogen expanded depressurized gas in line **156** from the gas expander **152** (Figure 1). In one embodiment, the nitrogen expanded depressurized gas in line **156** is injected at or near the bottom of the first column **202** and rises through the tower until it is discharged at or near the top via nitrogen outlet stream **206**. In at least one embodiment, the nitrogen outlet stream **206** can discharge its contents to the atmosphere or be sold as an inert gas. In other embodiments, the nitrogen in the stream **206** can be pressurized for pressure maintenance or EOR applications.

[0053] Because the nitrogen expanded depressurized gas in line 156 can be at or near atmospheric pressure, the first column 202 can be adapted to operate at or near atmospheric pressure. As the nitrogen ascends the first column 202, a stream of water or cooling water supply in line 208 can be injected at or near the top of the first column 202. In one or more  
5 embodiments, the cooling water supply in line 208 can be obtained from a local body of water, such as a lake, river, or the ocean. Accordingly, depending on the time of year and the ambient temperature of the specific geographic location where the system 100 is located, the cooling water supply in line 208 can be injected at varying temperatures, but most likely  
10 evaporates by absorbing heat energy from the dry nitrogen, thereby cooling the water and discharging cooled water via stream 210. Evaporated water can be collected with the nitrogen gas, thereby resulting in a saturated nitrogen being discharged via line 206. Depending on the intended use of the nitrogen stream in line 206, the water vapor therein may be removed through any suitable methods.

15 [0054] The second column 204 can be configured to receive the cooled water stream 210 at or near its top. As depicted, the second column 204 can also receive the pressurized recycle gas in line 145 discharged from the second cooling unit 136 (FIG. 1) at or near its bottom. The illustration of the pressurized recycle gas in line 145 is representative of any  
20 exhaust gas stream in the exhaust gas recycle loop. Because the pressurized recycle stream 145 can be injected at pressures ranging from about 17 psia to about 21 psia, as discussed above, the cooled water stream 210 may be correspondingly pressurized using at least one pump 212, or similar mechanism, when appropriate. As the cooled water stream 210 and the pressurized recycle gas in line 145 course through the second column 204, the pressurized  
25 recycle gas in line 145 is cooled and eventually exits via stream 214 to be subsequently directed to the suction of the main compressor 104 (FIG. 1). In some implementations, the column 204 may include multiple stages or contacting surfaces to enhance the interaction between the recycle stream 145 and the cooled water stream 210. Additionally or  
alternatively, multiple towers may be used in series or in parallel, either in the place of the first column 202, the second column 204, or both, as may be desired.

30 [0055] A cooling water return, at a temperature generally warmer than the water in line 210, exits the second column 204 via line 216. As can be appreciated, cooling the pressurized recycle gas in line 145 can result in the condensation of more water derived from the pressurized recycle gas in line 145. This condensed water can be collected and discharged with the cooling water return in line 216, thereby generating an even drier



pressurized recycle gas in line **145** exiting via stream **214**. In at least one embodiment, the cooling water return can be re-routed and re-introduced into the first column via line **208**. In other embodiments, however, the cooling water return can be harmlessly discharged to a local body of water or used as irrigation water.

5 [0056] As discussed above in connection with FIG. 1, before being introduced into the third cooling unit **200**, the pressurized recycle gas in line **145** can be previously cooled in the second cooling unit **136** (FIG. 1) to a temperature of about 105 °F. The amount of overall cooling experienced by the pressurized recycle gas in line **145** in the third cooling unit **200** can depend on the flow rate of the cooled water from stream **210** coursing through the second  
10 column **204**.

[0057] Embodiments of the present disclosure can be further described with the following simulated examples. Although the simulated examples are directed to specific embodiments, they are not to be viewed as limiting the disclosure in any specific respect. Table 1 below provides illustrative flow rates of the water in stream **210** and its effect on the cooling process  
15 in the third cooling unit **200**.

**TABLE 1**

<b>Effect of Nitrogen Evaporative Cooling on Exhaust Gas Recirculation</b>			
<b>Water Rate (GPM)</b>	<b>N<sub>2</sub> Outlet Temp (F)</b>	<b>Water Outlet Temp (F)</b>	<b>Pressurized Recycle Gas Temp (F)</b>
100	62.1	61.4	97.7
250	63.2	61.4	97.5
500	64.9	61.4	97.2
1000	68.1	61.6	96.6
2500	76.0	63.1	94.8
5000	84.5	67.7	92.2
7500	89.5	72.1	90.4
10000	92.5	75.9	89.3
11000	93.4	77.2	89.0
12500	96.0	77.6	88.7
15000	95.9	81.4	88.5
20000	98.6	84.4	88.8

[0058] From Table 1, it should be apparent that as the flow rate of the water in line **210** increases, the outlet temperature of the nitrogen stream via line **206** also increases as a direct  
20 result of heat transfer heat with an increased amount of water. Likewise, an increase in flow rate of water in line **210** results in an increase in the temperature of the water outlet in line

210. As a result, the pressurized recycle gas exiting via line 214 decreases in temperature relative to the increasing flow rate of the water in line 210. As can be appreciated, several variables can affect the temperature of the pressurized recycle gas exiting via line 214 including, but not limited to, the temperature of the incoming nitrogen exhaust gas in line 5 156, the temperature of the cooling water supply in line 208, the configuration and number of stages in the towers, etc. In at least one embodiment, the cooling water supply in line 208 can be injected into the first column 202 at a temperature of about 80 °F to about 85 °F.

[0059] Table 2 below provides a performance comparison between a system where a cooling unit 200 is employed, such as the evaporative cooling unit as described herein, and a 10 system without such a cooling unit 200.

**TABLE 2**

<b>Triple -Cycle Performance Comparison</b>		
<b>Power (MW)</b>	<b>Cycle - No Inlet Cooling</b>	<b>Cycle Inlet Cooling</b>
Gas Turbine Expander Power	1150	1155
Main Compressor	542	519
Fan or Boost Compressor	27	19
Inlet Compressor	315	318
Total Compression Power	883	856
Net Gas Turbine Power	258	291
Steam Turbine Net Power	339	339
Standard Machinery Net Power	597	629
Aux. Losses	13	14
Nitrogen Expander Power	203	191
<b>Combined Cycle Power</b>	<b>787</b>	<b>807</b>
<i>Efficiency</i>		
Fuel Rate (Mbtu/hr)	6322	6390
Heat Rate (BTU/kWh)	9727	7921
<b>Combined Cycle Eff (%lhv)</b>	<b>42.5</b>	<b>43.1</b>
CO <sub>2</sub> Purge Pressure (psia)	308	308

[0060] As should be apparent from Table 2, embodiments including cycle inlet cooling, such as employing the third cooling unit 200, can increase the combined-cycle power output. 15 Although a decrease in power output from the nitrogen expander may be experienced, its decrease is more than offset by an increase in net gas turbine power (*i.e.*, the expander 106) which translates into an increase in CO<sub>2</sub> purge pressure (*i.e.*, the main compressor 104 discharge pressure). Furthermore, the overall combined cycle power output can be increased by about 0.6% lhv (lower heated value) by implementing inlet cooling as described herein.

- [0061] The present disclosure also contemplates using a mechanical refrigeration system (not shown) as the third cooling unit **200**, in place of the evaporative cooling unit described herein. While the total required compression power of the main compressor **104** may be adequately reduced using a mechanical refrigeration system, there can be a corresponding
- 5 reduction in the mass flow through the main compressor **104** which would adversely affect the power produced. A trade-off between main compressor **104** power reduction and expander **106** power production must be considered for an optimum process cycle performance. Moreover, the cost of the additional cooling equipment should be considered for a cost-premium solution.
- 10 [0062] While the present disclosure may be susceptible to various modifications and alternative forms, the exemplary embodiments discussed above have been shown only by way of example. However, it should again be understood that the disclosure is not intended to be limited to the particular embodiments disclosed herein. Indeed, the present disclosure includes all alternatives, modifications, and equivalents falling within the true spirit and
- 15 scope of the appended claims.

THE CLAIMS DEFINING THE INVENTION ARE AS FOLLOWS:

1. An integrated system, comprising:

a gas turbine system having a combustion chamber configured to substantially stoichiometrically combust a compressed oxidant and a fuel in the presence of a compressed recycle exhaust gas, wherein the compressed recycle exhaust gas moderates a temperature of combustion in the combustion chamber, and the combustion chamber directs a discharge to an expander configured to generate a gaseous exhaust stream and at least partially drive a main compressor;

an exhaust gas recirculation system having at least one cooling unit, wherein the at least one cooling unit cools the gaseous exhaust before injection into the main compressor to generate the compressed recycle exhaust gas

a CO<sub>2</sub> separator fluidly coupled to the compressed recycle exhaust gas via a purge stream and configured to discharge a residual stream consisting primarily of nitrogen gas to be expanded in a gas expander and generate a nitrogen exhaust gas, wherein the nitrogen exhaust gas is injected into the at least one cooling unit to cool the gaseous exhaust stream; and

a residual cooling unit fluidly coupled to the residual stream and configured to reduce the temperature of the residual stream and extract condensed water therefrom;

wherein the at least one cooling unit is an evaporative cooling unit comprising:

a first column configured to receive the nitrogen exhaust gas and a cool water supply, wherein the nitrogen exhaust gas evaporates a portion of the cool water supply to cool the cool water supply and generate a cooled water discharge, and

a second column configured to receive the cooled water discharge and the gaseous exhaust, wherein interaction between the cooled water discharge and the gaseous exhaust stream cools the gaseous exhaust stream.

2. The system of claim 1, further comprising at least one additional cooling unit, wherein the additional cooling unit is fluidly coupled to the at least one cooling unit, and wherein the additional cooling unit cools the gaseous exhaust stream to a temperature of about 105 °F.

3. The system of claim 1 or 2, wherein the at least one cooling unit reduces the temperature of the gaseous exhaust stream to below about 100 °F.

4. The system of any one of claims 1 to 3, wherein the cooled water discharge is pressurized with a pump before being introduced into the second column.

5. The system of any one of claims 1 to 4, wherein the second column is further configured to condense and extract an amount of water from the gaseous exhaust stream.

6. The system of any one of the preceding claims, further comprising a heat exchanger fluidly coupled to the purge stream and configured to reduce the temperature of the purge stream prior to being introduced into the CO<sub>2</sub> separator.

7. The system of any one of the preceding claims, further comprising a boost compressor adapted to increase the pressure of the gaseous exhaust stream to a pressure between about 17 psia and about 21 psia before injection into the main compressor.

8. A method of generating power, comprising:

substantially stoichiometrically combusting a compressed oxidant and a fuel in a combustion chamber and in the presence of a compressed recycle exhaust gas, thereby generating a discharge stream, wherein the compressed

recycle exhaust gas acts as a diluent configured to moderate the temperature of the discharge stream;

expanding the discharge stream in an expander to at least partially drive a main compressor and generate a gaseous exhaust stream;

directing the gaseous exhaust stream into at least one cooling unit;

cooling the gaseous exhaust stream in the at least one cooling unit before injecting the gaseous exhaust stream into the main compressor to generate the compressed recycle exhaust gas;

directing a portion of the compressed recycle exhaust gas to a CO<sub>2</sub> separator via a purge stream, the CO<sub>2</sub> separator being configured to discharge a residual stream consisting primarily of nitrogen- gas to be expanded in a gas expander and generate a nitrogen exhaust gas;

cooling the residual stream with a residual cooling unit fluidly coupled to the CO<sub>2</sub> separator ;

extracting condensed water from the residual stream; and

injecting the nitrogen exhaust gas into the at least one cooling unit to cool the gaseous exhaust stream,

wherein the at least one cooling unit is an evaporative cooling unit comprising:

a first column configured to receive the nitrogen exhaust gas and a cool water supply, wherein the nitrogen exhaust gas evaporates a portion of the cool water supply to cool the cool water supply and generate a cooled water discharge, and

a second column configured to receive the cooled water discharge and the gaseous exhaust, wherein interaction between the cooled water discharge and the gaseous exhaust stream cools the gaseous exhaust stream.

9. The method of claim 8, further comprising cooling the gaseous exhaust stream in at least one pre-cooling unit disposed before a final cooling unit to a temperature of about 105 °F, wherein the at least one pre-cooling unit is fluidly coupled to the final cooling unit.

10. The method of claim 9, further comprising:

receiving the nitrogen exhaust gas and a cool water supply in a first column of the at least one cooling unit;

evaporating a portion of the cool water supply to cool the cool water supply and generate a cooled water discharge;

receiving the cooled water discharge and the gaseous exhaust stream in a second column of the at least one cooling unit; and

cooling the gaseous exhaust stream to a temperature below about 100 °F with the cooled water discharge.

11. The method of claim 10, further comprising pressurizing the cooled water discharge with a pump before being introduced into the second column.

12. The method of claim 10, further comprising condensing and extracting an amount of water from the gaseous exhaust stream in the second column.

13. The method of any one of claims 8 to 12, further comprising reducing the temperature of the purge stream in a heat exchanger fluidly coupled to the purge stream and configured to reduce the temperature of the purge stream prior to being introduced into the CO<sub>2</sub> separator.

14. A combined-cycle power generation system, comprising:

a combustion chamber configured to substantially stoichiometrically

combust a compressed oxidant and a fuel in the presence of a compressed recycle exhaust gas, wherein the combustion chamber directs a discharge to an expander configured to generate a gaseous exhaust stream and drive a main compressor;

an evaporative cooling tower having a first column and a second column, wherein the second column is configured to receive and cool the gaseous exhaust stream before being compressed in the main compressor to generate the compressed recycle exhaust gas; and

a condenser fluidly coupled to the residual stream and configured to reduce the temperature of the residual stream and extract condensed water therefrom.

a CO<sub>2</sub> separator fluidly coupled to the compressed recycle exhaust gas via a purge stream and configured to discharge a residual stream consisting primarily of nitrogen gas to be expanded in a gas expander and generate a nitrogen exhaust gas, wherein the nitrogen exhaust gas is injected into the first column to evaporate and cool a cooling water supply to discharge a cooled water, and wherein the cooled water is injected into the second column to cool the gaseous exhaust stream.

15. The system of claim 14, wherein evaporative cooling tower further comprises a pump configured to pressurize the cooled water and inject the cooled water into the second column in order to cool the gaseous exhaust stream.

16. The system of claim 14 or 15, wherein the second column is a direct contact cooler.

17. The system of claim 16, wherein the second column is a multi-stage direct contact cooler.



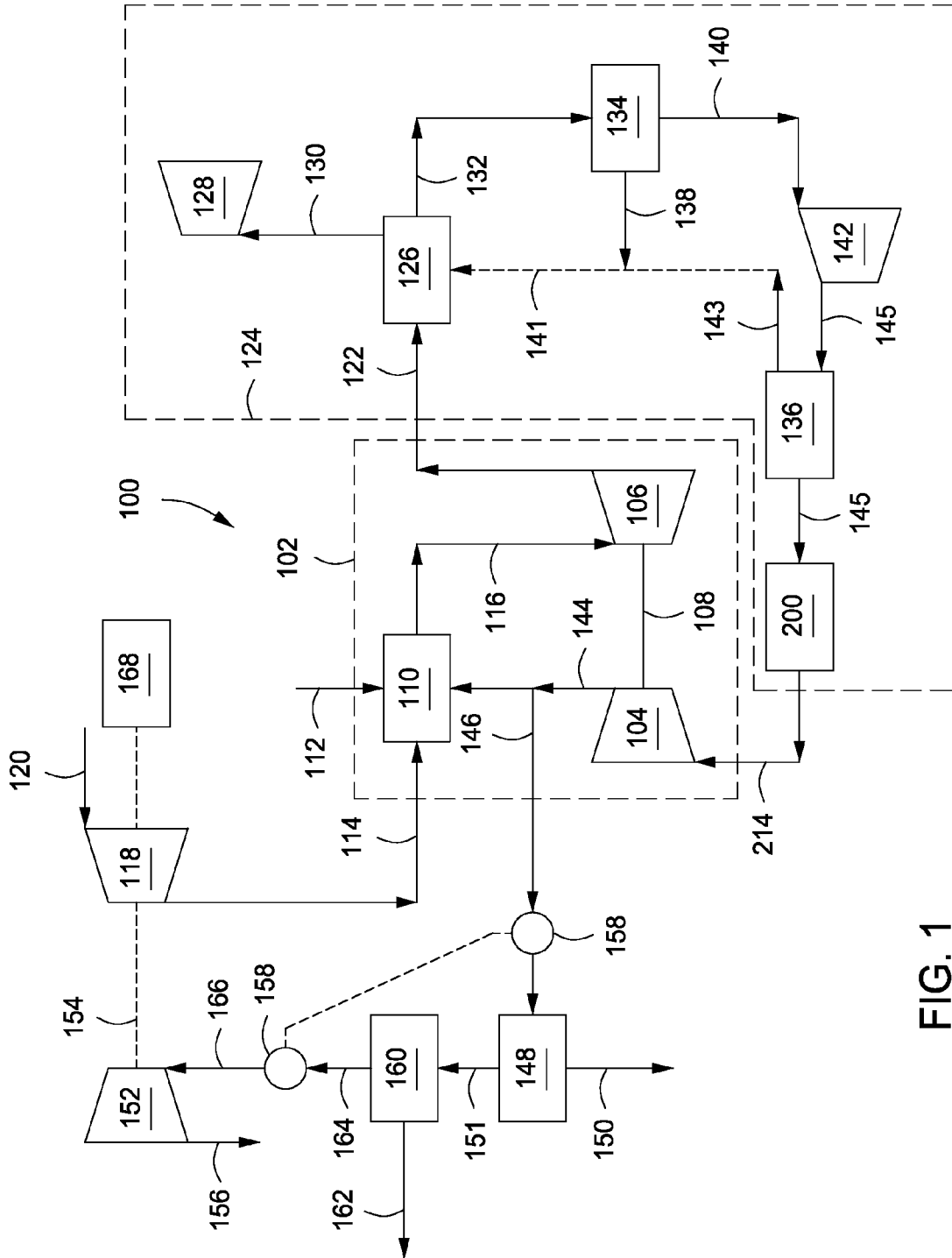

FIG. 1

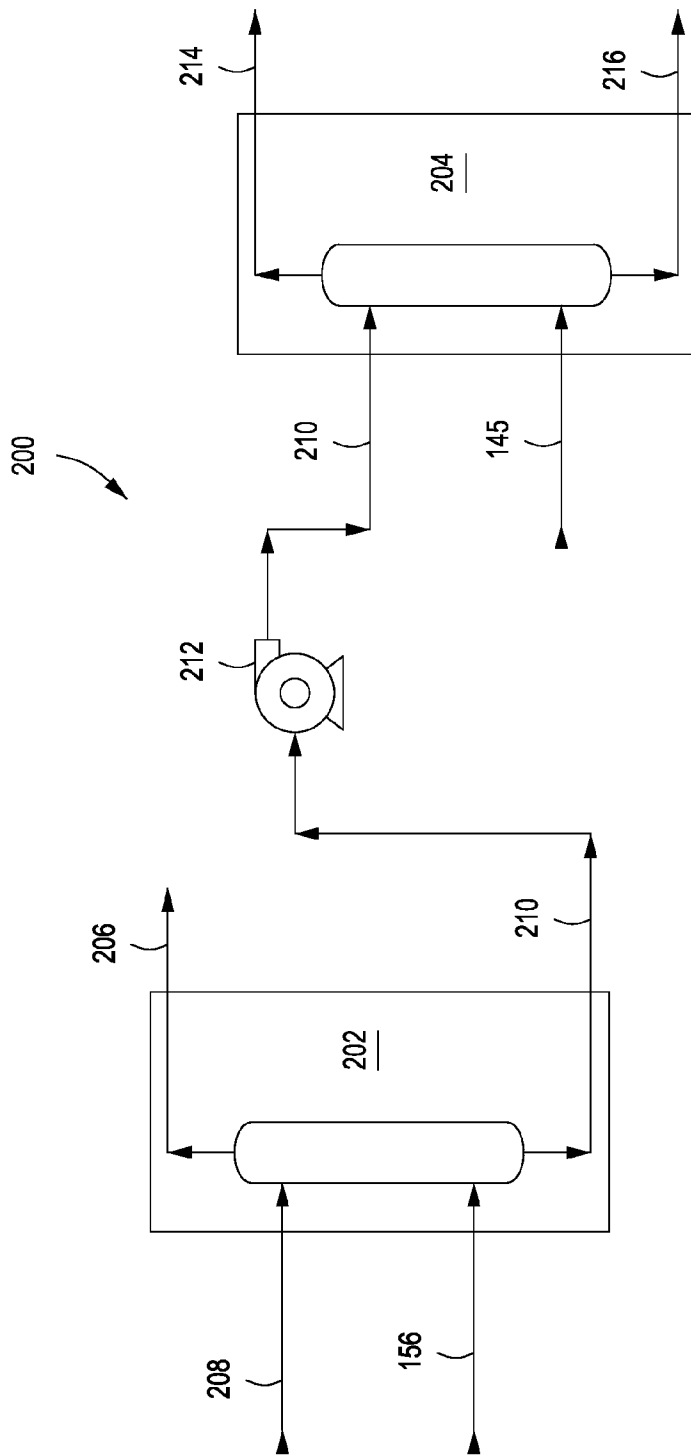

FIG. 2