

(19)



Europäisches Patentamt

European Patent Office

Office européen des brevets



(11)

**EP 0 781 439 B1**

(12)

**EUROPEAN PATENT SPECIFICATION**

(45) Date of publication and mention of the grant of the patent:  
**08.07.1998 Bulletin 1998/28**

(51) Int Cl.<sup>6</sup>: **G07F 3/02**, G07D 5/00,  
G07D 7/00

(21) Application number: **95930665.5**

(86) International application number:  
**PCT/GB95/02125**

(22) Date of filing: **08.09.1995**

(87) International publication number:  
**WO 96/07992 (14.03.1996 Gazette 1996/12)**

**(54) APPARATUS FOR VALIDATING ITEMS OF VALUE, AND METHOD OF CALIBRATING SUCH APPARATUS**

VORRICHTUNG ZUM PRÜFEN VON WERTGEGENSTÄNDEN UND VERFAHREN ZUM KALIBRIEREN EINER SOLCHEN VORRICHTUNG

APPAREIL DE VALIDATION D'ARTICLES DE VALEUR ET PROCEDE D'ETALONNAGE DE CET APPAREIL

(84) Designated Contracting States:  
**DE ES FR**

• **STEEL, Paul, Franklin**  
**Wokingham Berkshire RG11 4TA (GB)**

(30) Priority: **09.09.1994 GB 9418185**

(74) Representative: **Burke, Steven David et al**  
**R.G.C. Jenkins & Co.**  
**26 Caxton Street**  
**London SW1H 0RJ (GB)**

(43) Date of publication of application:  
**02.07.1997 Bulletin 1997/27**

(73) Proprietor: **MARS INCORPORATED**  
**McLean, Virginia 22101-3883 (US)**

(56) References cited:  
**EP-A- 0 227 453**                      **EP-A- 0 394 067**  
**US-A- 4 451 929**                      **US-A- 4 538 719**  
**US-A- 4 572 349**                      **US-A- 5 052 043**

(72) Inventors:  
• **BILLINGTON, Gregory, John**  
**Reading Berkshire RG6 4HL (GB)**

**EP 0 781 439 B1**

Note: Within nine months from the publication of the mention of the grant of the European patent, any person may give notice to the European Patent Office of opposition to the European patent granted. Notice of opposition shall be filed in a written reasoned statement. It shall not be deemed to have been filed until the opposition fee has been paid. (Art. 99(1) European Patent Convention).

## Description

This invention relates to apparatus for validating items of value, and to methods of calibrating such apparatus. The invention will be described in the context of coin validators, but is also applicable to banknote validators and validators for other items of value.

It is well known to take measurements of coins and apply acceptability tests to determine whether the coin is valid and the denomination of the coin. The acceptability tests are normally based on stored acceptability data. One common technique (see, e.g. GB-A-1 452 740) involves storing "windows", i.e. upper and lower limits for each test. If each of the measurements of a coin falls within a respective set of upper and lower limits, then the coin is deemed to be acceptable. The acceptability data could instead represent a predetermined value such as a median, the measurements then being tested to determine whether they lie within predetermined ranges of that value. Alternatively, the acceptance data could be used to modify each measurement and the test would then involve comparing the modified result with a fixed value or window. Alternatively, the acceptance data could be a look-up table which is addressed by the measurements, and the output of which indicates whether the measurements are suitable for a particular denomination (see, e.g. EP-A-0 480 736, and US-A-4 951 799). Instead of having separate acceptance criteria for each test, the measurements may be combined and the result compared with stored acceptance data (cf. GB-A-2 238 152 and GB-A-2 254 949). Alternatively, some of these techniques could be combined, e.g. by using the acceptability data as coefficients (derived, e.g. using a neural network technique) for combining the measurements, and possibly for performing a test on the result. A still further possibility would be for the acceptability data to be used to define the conditions under which a test is performed (e.g. as in US-A-4 625 852).

It is known to use statistical techniques for deriving the data, e.g. by feeding many items into the validator and deriving the data from the test measurements in a calibration operation. It is also known for the validator to have an automatic re-calibration function, sometimes known as "self-tuning", whereby the acceptance data is regularly updated on the basis of measurements performed during testing (see for example EP-A-0 155 126, GE-A-2 059 129, and US-A-4 951 799).

Normally, the acceptance data produced by the calibration operation is characteristic of the specific type of item to be validated. However, it is alternatively possible for the data to be independent of the properties of the item itself, and instead to be characteristic of just the validation apparatus (e.g. to represent how much the apparatus deviates in its measurements from a standard) so that this data in combination with further data representing the standard properties of an item are sufficient for validation.

It is sometimes desirable to calibrate or recalibrate an existing validator in the field (c.f. GB-A-2 199 978). For example, if the validator is arranged to validate a certain range of denominations, it may be desired to add a different denomination to that range, or to substitute one of those denominations for a different one. However, it is desirable to avoid the need to perform a very large number of tests during the calibration step if the apparatus is in the field, and also if the calibration is carried out using the internal control system of the validator or possibly using a hand-held terminal connected to the validator, there is a limit to the amount of available memory capacity, which inhibits the use of normal statistical techniques. The results therefore may be statistically unreliable.

EP-A-0 227 453 describes a coin validation apparatus which can be put into a "training" mode, in which a coin is inserted into the testing apparatus four times in succession, in order to develop acceptance criteria for validating further coins of the same type. Four sets of measurements are made to ensure that the results are representative of the particular coin type. The sets of measurements must match closely, in order for the operation to be completed. This prevents possible errors due to an incorrect coin being inserted. If four consecutive close matches are not found, then the entire operation must be repeated. Once there are four consecutive close matches, the measurements are then averaged, and the results define acceptance criteria used in the test mode of the apparatus. The use of only four measurements means that the resulting acceptance criteria may not be statistically very accurate. The disclosed technique requires the storage of all the measurements for all four coins, and therefore increasing the number of required tests during the calibration mode will substantially increase the memory requirements.

Aspects of the present invention are set out in the accompany claims.

Arrangements according to the invention could employ any of the techniques mentioned above.

In accordance with the method of the invention, successive measurements are used for successively updating the acceptability data. Thus, it is not essential that these measurements thereafter be retained, so that the memory requirement can be reduced. Even though not all the measurements are retained, it is still possible to apply suitability criteria to each of the measurements to determine whether it is suitable for use in updating the acceptability data. Thus, for example, if a measurement differs from the current acceptability data by more than a predetermined amount, it is deemed anomalous and not used for updating the acceptability data. This is particularly useful in the context of coin validators, and especially those in which the coin is allowed to pass through the validator under the force of gravity (rather than being transported on a conveyor). In these circumstances, a coin may follow a different path from the intended one, thus giving rise to the anomalous measure-

ment. However, anomalies are also possible in other circumstances, such as in banknote validation wherein the banknote may be aligned in a slightly incorrect manner as it passes through the validator, or is dirty or damaged.

A problem may arise if the first of the tested items produces measurements which are statistically unsound. If these are used to derive acceptability data, then subsequent (non-anomalous) measurements may incorrectly be treated as anomalous because of the disparity with the first measurement. To deal with this, in a preferred embodiment of the invention, the first measurement is discarded if it does not lie within a predetermined range of the second measurement. If the first measurement is discarded, then the second measurement is thereafter treated as though it were the first. Accordingly, the acceptability data only starts being updated when there are two successive measurements lying within a predetermined range.

Preferably, means are provided for preventing the acceptability data from being used in subsequent testing operations if an inadequate number of measurements have passed the suitability criterion and/or if an excessive number of measurements have failed the suitability criterion.

An arrangement embodying the invention will now be described by way of example with reference to the accompanying drawings, in which:

Figure 1 is a schematic view of a coin mechanism including a coin validator in accordance with the invention;

Figure 2 is a schematic block diagram of the circuitry of the validator;

Figure 3 is a flowchart illustrating the operation of the validator; and

Figure 4 is a flowchart illustrating the calibration part of the operation.

Referring to Figure 1, a coin mechanism 2 has a validator 4 which comprises a hopper 6 into which coins can be inserted. The coins fall on to a ramp 8 and then roll under gravity down the ramp past a testing region indicated by the shaded section 10. The coins then fall towards an accept gate shown schematically at 12. If the coins have been tested and found not to be genuine, the coins are diverted by the accept gate 12 into a reject path 14, which delivers the coins to a refund tray 16.

If the coins are acceptable, a solenoid is energised to cause the accept gate 12 to shift into a position in which it opens an accept path 18 leading to an escrow bucket 20. Coins entering the accept path 18 move past a sensing arrangement shown generally at 22. After the sensing arrangement 22 has detected that a coin has moved past, it triggers the accumulation of credit, thus permitting a user to operate a machine (not shown) in which the validator is housed. After the machine has provided goods or a service to the value of the accumulated credit, an escrow accept gate 24 is opened to allow

a coin or coins held thereby to fall into a cash box 26. Before provision of the goods or services, the user can alternatively press an escrow return button (not shown) to cause an escrow return gate 28 to open and so allow coins in the escrow bucket 20 to travel to the refund tray 16.

Arrangements generally of this type are well known, although the physical structure of such arrangements varies substantially.

The circuitry 30 of the coin testing apparatus shown schematically in Figure 2 includes a set of coin sensors indicated at 34 forming the testing section 10. Each of these sensors is operable to measure a different property of a coin inserted in the apparatus, in a manner which is in itself well known. Each sensor provides a signal indicating the measured value of the respective parameter on one of a set of output lines indicated at 36.

An LSI 38 receives these signals. The LSI 38 contains a read-only memory storing an operating program which controls the way in which the apparatus operates. Instead of an LSI, a standard microprocessor may be used. The LSI is operable to compare each measured value received on a respective one of the input lines 36 with values (constituting acceptance data) stored in predetermined locations in an EPROM 40. The EPROM 40 could be any other type of memory circuit with alterable contents, and could be formed of a single or several integrated circuits, or may be combined with the LSI 38 (or microprocessor) into a single integrated circuit.

The LSI 38, which operates in response to timing signals produced by a clock 42, is operable to address the PROM 40 by supplying address signals on an address bus 44. The LSI also provides a "EPROM-enable" signal on line 46 to enable the PROM. In response to the addressing operation, a value is delivered from the PROM 40 to the LSI 38 via a data bus 48.

The LSI 38 also has input lines 50 for receiving signals from a keyboard 52 housed in the host vending machine and accessible only to an operator who has a key to unlock the machine, and for receiving signals from other parts of the vending machine indicated generally at 54. Instead of a keyboard, simple switches (e.g. Dual-In-Line switches) could be used. Alternatively, the LSI could be controlled by signals received from other equipment to which the validator is connected.

By way of example, one embodiment of the invention may comprise three sensors, for respectively measuring the conductivity, thickness and diameter of inserted coins. On insertion of a coin, the measurements produced by the three sensors 34 are compared by the LSI 38 with selected values stored in the EPROM 40. If the measured thickness value lies within a predetermined range of the stored thickness value for a particular coin, then the thickness test for that coin has been passed. Similarly, the validator checks whether the diameter measurement and the conductivity measurement are within predetermined ranges of stored values.

If and only if all the measured values fall within the

three stored ranges for a particular coin denomination which the apparatus is designed to accept, the LSI 38 produces an ACCEPT signal on one of a group of output lines 56, and a further signal on another of the output lines 56 to indicate the denomination of the coin being tested. The accept gate 12 adopts one of two different states depending upon whether the ACCEPT signal is generated, so that all tested coins deemed genuine are directed along the accept path 18 and all other tested items along the reject path 14.

Figure 3 shows an example of how the validator may be arranged to operate, the figure relating only to those parts of the operation which are relevant to the present invention. The operation starts at step 400, and then following an initialization operation proceeds to step 410 where the validator checks to determine whether a coin has been inserted. If not, the program proceeds to step 420 to determine whether the keyboard 52 has been operated in such a manner as to instruct the machine to enter a calibration mode. For example, the machine may check to determine whether the operator has pressed a specific key or key sequence associated with this mode. If so, the program proceeds to step 422 to set a CALIBRATION flag indicating that the calibration mode has been entered. Various variables are also initialised, as described below. In any event, the program loops back to step 410, so that the validator again checks to determine whether a coin has been inserted.

The program proceeds in this fashion until a coin is inserted, and then proceeds to step 427. At this step the coin properties are measured.

Subsequently, at step 428, the program checks whether the CALIBRATION flag is set. If so, the calibration routine 429 (described in more detail in connection with Figure 4) is performed. Otherwise the program proceeds to step 430.

At step 430, the program checks whether the measured values fall within the ranges for an acceptable coin, as described above. If so, the program proceeds to step 432, whereupon the ACCEPT signal and the signal indicating the denomination of the inserted coin are issued. If the measured properties did not fall within any of the stored sets of ranges, the program proceeds to step 434, where the inserted item is rejected, and then loops back to step 410.

Assuming that the calibration routine is to be entered, then the step 422 initialises the following variables:

COIN\_COUNT: the number of coins measured during the calibration operation;  
 GOOD\_COINS: the number of coins whose measurements have passed the suitability criteria;  
 CURRENT\_DATA[n]: an n-dimensional array representing the n measurements of an item currently being measured;  
 SENSOR\_DATA[n]: an n-dimensional array, each

element of the array representing the accumulated total of the measurement results (for a particular type of measurement) for all items whose measurements have passed the suitability criteria.

All these variables are set to zero at step 422.

Subsequently, the calibration routine 429 (see Fig. 4) is executed. This starts at step 102. At step 104, COIN\_COUNT is incremented and the coin measurements are stored in CURRENT\_DATA[n]. At step 110, the program checks to determine whether GOOD\_COINS is greater than zero. Assuming that it is not, i.e. that no coins have yet had their measurements pass the suitability criteria, then the program proceeds to step 112, whereupon the current readings are used to update the acceptability data. Thus, the current values of the elements of SENSOR\_DATA[n] (which will initially be zero) are increased by the values of CURRENT\_DATA[n]. Also at step 112, the value of GOOD\_COINS is incremented.

The step 112 then involves the setting of the elements of another variable array, AVERAGE\_DATA[n], equal to the corresponding element of SENSOR\_DATA[n] divided by the value of GOOD\_COINS. AVERAGE\_DATA[n] therefore represents the average of the measurements which have passed the suitability criteria.

Thereafter, at step 114, the program determines whether a sufficient number (for example 20) of items have been tested, i.e. COIN\_COUNT = 20?, and if not, the routine ends at step 128, so the program loops back to step 410 (Figure 3). After the next coin has been tested, step 110 determines that GOOD\_COINS is greater than zero, and therefore proceeds to step 116. At this step, a suitability criterion is applied to each of the coin's measurements. If all the suitability criteria are met, the program proceeds to step 112, whereupon GOOD\_COINS is incremented, and the elements of CURRENT\_DATA[n] are added to SENSOR\_DATA[n]. Otherwise, the program proceeds to a "reject readings" step 118.

The suitability test at step 116 is failed if, for any one of the n measurements:

$ABS(CURRENT\_DATA[n] - AVERAGE\_DATA[n]) > window[n]$ ,

where window[n] is an array containing predetermined values for each measurement. Each value represents a range within which successive measurements must fall for the measurements to be deemed suitable. If the normal testing operation of the validator involves comparing the measurement of an item with upper and lower limits, then window[n] may represent the difference between these limits.

At step 118, which is reached if at least one of the suitability criteria is failed, the program tests to determine whether the value of GOOD\_COINS is equal to one. If it is not equal to one, the program proceeds to step 114, i.e. the CURRENT\_DATA[n] readings are sim-

ply ignored, and the value of GOOD\_COINS is not incremented. However, if GOOD\_COINS equals one, i.e. only one set of measurements has been used to contribute towards the current values of SENSOR\_DATA[n] and AVERAGE\_DATA[n], there is a possibility that these existing measurements are anomalous. Accordingly, the program proceeds to step 120, where the values of SENSOR\_DATA[n] are set equal to CURRENT\_DATA [n] (so that the CURRENT\_DATA[n] for the previous item is discarded) and the values of AVERAGE\_DATA [n] are re-calculated to be SENSOR\_DATA[n] divided by GOOD\_COINS.

This operation continues until, at step 114, it is detected that 20 items have been tested.

The program then proceeds to step 122. Here, the program determines whether the difference between COIN\_COUNT and GOOD\_COINS is less than a predetermined limit value. This difference represents the number of items rejected because the suitability criteria were not met. If this number is large, i.e. if the test at step 122 is failed, then the program proceeds to step 124, whereupon a warning display is provided to indicate that the re-calibration operation has failed. Otherwise, the program proceeds from step 122 to step 126. At this point, the value of AVERAGE\_DATA[n] is stored in the appropriate place in the memory (EPROM 40) for use in subsequent testing operations. As indicated above, these testing operations involve taking measurements corresponding to those made in the calibration operation, and then determining whether or not these lie within a predetermined window width (possibly window[n] mentioned above) of the stored mean (i.e. AVERAGE\_DATA[n]).

At either step 126 or step 124, the CALIBRATION flag is reset, so that the calibration routine ends and the apparatus returns to the normal test mode.

If a "self-tuning" facility is provided then the variables used by this facility may also be initialised at step 126.

Instead of using the internal program of the validator, in an alternative embodiment the calibration routine is stored in a separate hand-held terminal 80 (Fig. 2) which can be connected to a serial port 82 of the validator and which includes a microprocessor 84 and a keyboard 86. In this case the validator routine of Fig. 3 is responsive at step 420 to instructions from the terminal 80 and passes the coin measurements to the terminal when control is passed to the terminal's processor 84 at step 429.

The invention has been described in the context of coin validators, but it is to be noted that the term "coin" is employed to mean any coin (whether valid or counterfeit), token, slug, washer, or other metallic object or item, and especially any metallic object or item which could be utilised by an individual in an attempt to operate a coin-operated device or system. A "valid coin" is considered to be an authentic coin, token, or the like, and especially an authentic coin of a monetary system or

systems in which or with which a coin-operated device or system is intended to operate and of a denomination which such coin-operated device or system is intended selectively to receive and to treat as an item of value.

Indeed the invention is considered to be particularly applicable to the validators which can handle (possibly in addition to ordinary coins) tokens which may be specially manufactured for particular establishments, and may bear a general resemblance to coins in that they are metallic and generally discshaped and of a similar size, although would normally be distinguishable from genuine coins by a coin validator. Recalibration of such validators to make them suitable for particular establishments is frequently desired.

In the above description, it is assumed that the calibration is carried out by measuring items which correspond to the type of items which are validated in normal use. It would also be possible for at least part of the calibration to involve the measuring of items which the apparatus is intended to reject, i.e. "slugs". In this case, the acceptance data generated by the calibration operation would be used in such a way that tested items which produce measurements similar to those used to derive the acceptance data would be rejected.

Although the above description relates to an arrangement in which the acceptability data contains only averages of measurements which are used as the median of acceptance ranges, it is possible additionally or alternatively to derive other data, such as standard deviations used to determine the widths of the acceptance ranges.

## Claims

1. A method of calibrating apparatus (4) for validating items of value, the method comprising:
  - causing the apparatus to take a plurality of item measurements while the apparatus is in a calibration mode, applying suitability criteria to the measurements, and deriving at least one acceptance criterion from measurements which meet the suitability criteria, so that the acceptance criterion can be used in a test mode of the apparatus for testing items;
  - characterised in that the suitability criteria are applied to the measurements in succession and acceptability data used to define the acceptance criterion is successively updated in accordance with successive measurements determined to be suitable.
2. A method as claimed in claim 1, wherein a measurement meets a suitability criterion if it is within a predetermined range of current acceptability data.
3. A method as claimed in claim 1 or claim 2, including the step of taking a first measurement before said

plurality of measurements, but preventing said first measurement from being used to produce the acceptability data if it does not lie within a predetermined range of the next measurement, in which case the next measurement is treated as the first measurement for use in producing the acceptability data.

4. A method as claimed in any preceding claim, including the step of causing the apparatus to measure a plurality of different items of the same type in order to derive said plurality of item measurements.

5. A method as claimed in any preceding claim, in which each item measurement is discarded after it is used to update the acceptability data.

6. A method as claimed in any preceding claim, wherein the acceptability data represents the average of measurements which have met the suitability criterion.

7. A method as claimed in any preceding claim, when the apparatus (4) is operable to perform a plurality of measurements on each item, and to use the plurality of measurements for updating the acceptability data, which is thereafter usable by the apparatus in defining a plurality of acceptance criteria for testing items, and wherein a respective suitability criterion is applied to each of the measurements of an item and all said measurements are prevented from being used to update the acceptability data if any one of them fails to meet the suitability criterion.

8. A method as claimed in any preceding claim, including the step of preventing the acceptability data from being usable by the apparatus (4) to define an acceptance criterion if at least a predetermined number of measurements have failed to meet the suitability criteria.

9. A method as claimed in any preceding claim, including the step of using the acceptability data to define the acceptance criterion even if not all the measurements have met their suitability criteria.

10. A method as claimed in any preceding claim, wherein the items are coins.

11. A method as claimed in any preceding claim, wherein the items are banknotes.

12. Apparatus for validating items of value, the apparatus (4) having a first mode in which at least one acceptance criterion is use for testing items, and a second mode for calibrating the apparatus by deriving the acceptability criterion, the apparatus being operable in the second mode to take a plurality of

item measurements, to apply suitability criteria to measurements and, if the suitability criteria are met, to use the measurements to define the acceptance criterion,

characterised in that acceptability data, which is used to define the acceptance criterion, is successively updated in accordance with successive measurements deemed to be suitable.

13. A device for calibrating apparatus for validating items of value, the device (80) comprising deriving from the apparatus (4) a plurality of item measurements, applying suitability criteria to measurements, and, if the suitability criteria are met, deriving an acceptance criterion in accordance with the measurements, whereby the acceptance criterion can be used by the apparatus for testing items,

characterised in that acceptability data, which is used to define the acceptance criterion, is successively updated in accordance with the successive measurements deemed to be suitable.

#### Patentansprüche

1. Verfahren zur Kalibrierung einer Vorrichtung (4) zum Prüfen von Wertgegenständen, aufweisend:

Veranlassen, daß die Vorrichtung mehrere Messungen an Gegenständen vornimmt, während sie sich in einem Kalibrierungsmodus befindet, Anwenden von Eignungskriterien auf die Messungen und Ableiten mindestens eines Annahmekriteriums aus Messungen, die die Eignungskriterien erfüllen, so daß das Annahmekriterium in einem Prüfmodus der Vorrichtung zum Prüfen von Gegenständen verwendet werden kann,

**dadurch gekennzeichnet**, daß die Eignungskriterien auf die Messungen in Folge angewendet werden und die zum Festlegen des Annahmekriteriums verwendeten Annahmedaten entsprechend den aufeinanderfolgenden Messungen, die als geeignet bestimmt werden, von Mal zu Mal aktualisiert werden.

2. Verfahren nach Anspruch 1, wobei eine Messung ein Eignungskriterium erfüllt, wenn sie innerhalb eines vorbestimmten Bereichs gegenwärtiger Annahmedaten liegt.

3. Verfahren nach Anspruch 1 oder 2, mit einem Schritt zur Vornahme einer ersten Messung vor den genannten Messungen, wobei jedoch verhindert wird, daß die erste Messung zur Erzeugung der Annahmedaten verwendet wird, wenn sie nicht innerhalb eines vorbestimmten Bereichs der nächsten Messung liegt, wobei dann die nächste Messung als erste Messung zur Verwendung bei der Erzeugung der Annahmedaten dient.

4. Verfahren nach einem der vorhergehenden Ansprüche, mit einem Schritt, um die Vorrichtung zu veranlassen, mehrere verschiedene Gegenstände des gleichen Typs zu messen, um die genannten Messungen an Gegenständen zu erhalten.
5. Verfahren nach einem der vorhergehenden Ansprüche, wobei jede Messung an einem Gegenstand nach der Verwendung zur Aktualisierung der Annahmedaten weggeworfen wird.
6. Verfahren nach einem der vorhergehenden Ansprüche, wobei die Annahmedaten den Mittelwert von Messungen, die das Eignungskriterium erfüllt haben, darstellen.
7. Verfahren nach einem der vorhergehenden Ansprüche, wobei die Vorrichtung (4) in der Lage ist, mehrere Messungen an jedem Gegenstand vorzunehmen und die Messungen zur Aktualisierung der Annahmedaten zu verwenden, die daraufhin von der Vorrichtung dazu verwendbar sind, mehrere Annahmekriterien zum Prüfen von Gegenständen festzulegen, und wobei auf jede der Messungen an einem Gegenstand ein entsprechendes Eignungskriterium angewandt wird und von allen diesen Messungen eine Verwendung zur Aktualisierung der Annahmedaten verhindert wird, wenn irgendeine von ihnen das Eignungskriterium nicht erfüllt.
8. Verfahren nach einem der vorhergehenden Ansprüche, mit einem Schritt zum Verhindern, daß die Annahmedaten von der Vorrichtung (4) zur Festlegung eines Annahmekriteriums verwendbar sind, wenn mindestens eine vorbestimmte Anzahl an Messungen das Eignungskriterium nicht erfüllt haben.
9. Verfahren nach einem der vorhergehenden Ansprüche, mit einem Schritt zur Verwendung der Annahmedaten zum Festlegen des Annahmekriteriums auch dann, wenn nicht alle Messungen ihre Eignungskriterien erfüllt haben.
10. Verfahren nach einem der vorhergehenden Ansprüche, wobei die Gegenstände Münzen sind.
11. Verfahren nach einem der vorhergehenden Ansprüche, wobei die Gegenstände Banknoten sind.
12. Vorrichtung (4) zum Prüfung von Wertgegenständen, mit einem ersten Betriebsmodus, in dem mindestens ein Annahmekriterium zum Prüfen von Gegenständen verwendet wird, und einen zweiten Modus zum Kalibrieren der Vorrichtung durch Gewinnen des Annahmekriteriums, wobei die Vorrichtung in dem zweiten Betriebsmodus mehrere Messungen an Gegenständen vornehmen, Eignungskriterien auf die Messungen anwenden und dann, wenn

die Eignungskriterien erfüllt sind, die Messungen zum Festlegen des Annahmekriteriums verwenden kann,

**dadurch gekennzeichnet**, daß Annahmedaten, die zur Festlegung des Annahmekriteriums dienen, entsprechend aufeinanderfolgenden als geeignet angesehenen Messungen von Mal zu Mal aktualisiert werden.

- 10 13. Einrichtung zum Kalibrieren einer Vorrichtung zum Prüfen von Wertgegenständen, wobei die Einrichtung (80) von der Vorrichtung (4) mehrere Messungen an Gegenständen gewinnen, Eignungskriterien auf die Messungen anwenden und dann, wenn die Eignungskriterien erfüllt sind, entsprechend den Messungen ein Annahmekriterium gewinnen kann, wodurch das Annahmekriterium von der Vorrichtung zum Prüfen von Gegenständen verwendbar wird,

**dadurch gekennzeichnet**, daß Annahmedaten, die zur Festlegung des Annahmekriteriums dienen, entsprechend nacheinander erfolgreicher, als geeignet angesehenen Messungen von Mal zu Mal aktualisiert werden.

#### Revendications

- 30 1. Procédé d'étalonnage d'un appareil (4) destiné à valider des articles de valeur, le procédé comprenant :
 

le fait de faire effectuer par l'appareil une pluralité de mesures d'articles pendant que l'appareil est dans un mode d'étalonnage, l'application de critères de conformité aux mesures et la détermination d'au moins un critère d'acceptation d'après les mesures, satisfaisant aux critères de conformité, de façon que le critère d'acceptation puisse être utilisé dans un mode de test de l'appareil pour tester des articles ;

caractérisé en ce que les critères de conformité sont appliqués aux mesures en succession et les données d'acceptation utilisées pour définir le critère d'acceptation sont successivement mises à jour conformément aux mesures successives déterminées comme étant convenables.
- 40 2. Procédé selon la revendication 1, dans lequel une mesure satisfait à un critère d'acceptation si elle se trouve à l'intérieur d'une plage prédéterminée de données d'acceptation courantes.
- 45 3. Procédé selon la revendication 1 ou la revendication 2, comportant l'étape consistant à effectuer une première mesure avant ladite pluralité de mesures, mais empêcher ladite première mesure d'être utilisée pour produire les données d'acceptation si elle ne se trouve pas à l'intérieur d'une plage prédétermi-

minée de la mesure suivante, auquel cas la mesure suivante est traitée comme étant la première mesure pour être utilisée pour produire les données d'acceptation.

4. Procédé selon l'une quelconque des revendications précédentes, comportant l'étape consistant à faire mesurer par l'appareil une pluralité d'articles différents du même type pour déterminer ladite pluralité de mesures d'articles. 5
5. Procédé selon l'une quelconque des revendications précédentes, dans lequel chaque mesure d'article est éliminée après avoir été utilisée pour mettre à jour les données d'acceptation. 10
6. Procédé selon l'une quelconque des revendications précédentes, dans lequel les données d'acceptation représentent la moyenne des mesures ayant satisfait au critère de conformité. 15
7. Procédé selon l'une quelconque des revendications précédentes, lorsque l'appareil (4) peut être actionné pour effectuer une pluralité de mesures sur chaque article, et pour utiliser la pluralité de mesures pour mettre à jour les données d'acceptation, qui peuvent ensuite être utilisées par l'appareil pour définir une pluralité de critères d'acceptation pour tester des articles et dans lequel un critère de conformité respectif est appliqué à chacune des mesures d'un article et toutes lesdites mesures sont empêchées d'être utilisées pour mettre à jour les données d'acceptation si l'une quelconque d'entre elles ne parvient pas à satisfaire au critère de conformité. 20
8. Procédé selon l'une quelconque des revendications précédentes, comportant l'étape consistant à empêcher les données d'acceptation de pouvoir être utilisées par l'appareil (4) pour définir un critère d'acceptation, si au moins un nombre prédéterminé de mesures ne sont pas parvenues à satisfaire aux critères de conformité. 25
9. Procédé selon l'une quelconque des revendications précédentes, comportant l'étape consistant à utiliser les données d'acceptation pour définir le critère d'acceptation, même si toutes les mesures n'ont pas satisfait à leurs critères de conformité. 30
10. Procédé selon l'une quelconque des revendications précédentes, dans lequel les articles sont des pièces de monnaie. 35
11. Procédé selon l'une quelconque des revendications précédentes, dans lequel les articles sont des billets de banque. 40
12. Appareil pour valider des articles de valeur, l'appareil (4) ayant un premier mode dans lequel au moins un critère d'acceptation est utilisé pour tester des articles et un deuxième mode pour étalonner l'appareil en déterminant le critère d'acceptation, l'appareil pouvant être actionné dans le deuxième mode pour effectuer une pluralité de mesures d'articles, pour appliquer des critères de conformité aux mesures et, si les critères de conformité sont satisfaits, pour utiliser les mesures pour définir le critère d'acceptation, caractérisé en ce que des données d'acceptation, utilisées pour définir le critère d'acceptation, sont successivement mises à jour conformément à des mesures successives estimées être convenables. 45
13. Dispositif pour étalonner un appareil pour valider des articles de valeur, le dispositif (80) comprenant la détermination à partir de l'appareil (4) d'une pluralité de mesures d'articles, l'application de critères de conformité aux mesures et, si les critères de conformité sont satisfaits, la détermination d'un critère d'acceptation conformément aux mesures, de façon que le critère d'acceptation puisse être utilisé par l'appareil pour tester les articles, caractérisé en ce que les données d'acceptation, utilisées pour définir le critère d'acceptation, sont successivement mises à jour conformément aux mesures successives estimées être convenables. 50

reil (4) ayant un premier mode dans lequel au moins un critère d'acceptation est utilisé pour tester des articles et un deuxième mode pour étalonner l'appareil en déterminant le critère d'acceptation, l'appareil pouvant être actionné dans le deuxième mode pour effectuer une pluralité de mesures d'articles, pour appliquer des critères de conformité aux mesures et, si les critères de conformité sont satisfaits, pour utiliser les mesures pour définir le critère d'acceptation,

caractérisé en ce que des données d'acceptation, utilisées pour définir le critère d'acceptation, sont successivement mises à jour conformément à des mesures successives estimées être convenables.

13. Dispositif pour étalonner un appareil pour valider des articles de valeur, le dispositif (80) comprenant la détermination à partir de l'appareil (4) d'une pluralité de mesures d'articles, l'application de critères de conformité aux mesures et, si les critères de conformité sont satisfaits, la détermination d'un critère d'acceptation conformément aux mesures, de façon que le critère d'acceptation puisse être utilisé par l'appareil pour tester les articles,

caractérisé en ce que les données d'acceptation, utilisées pour définir le critère d'acceptation, sont successivement mises à jour conformément aux mesures successives estimées être convenables.



FIG. 1.

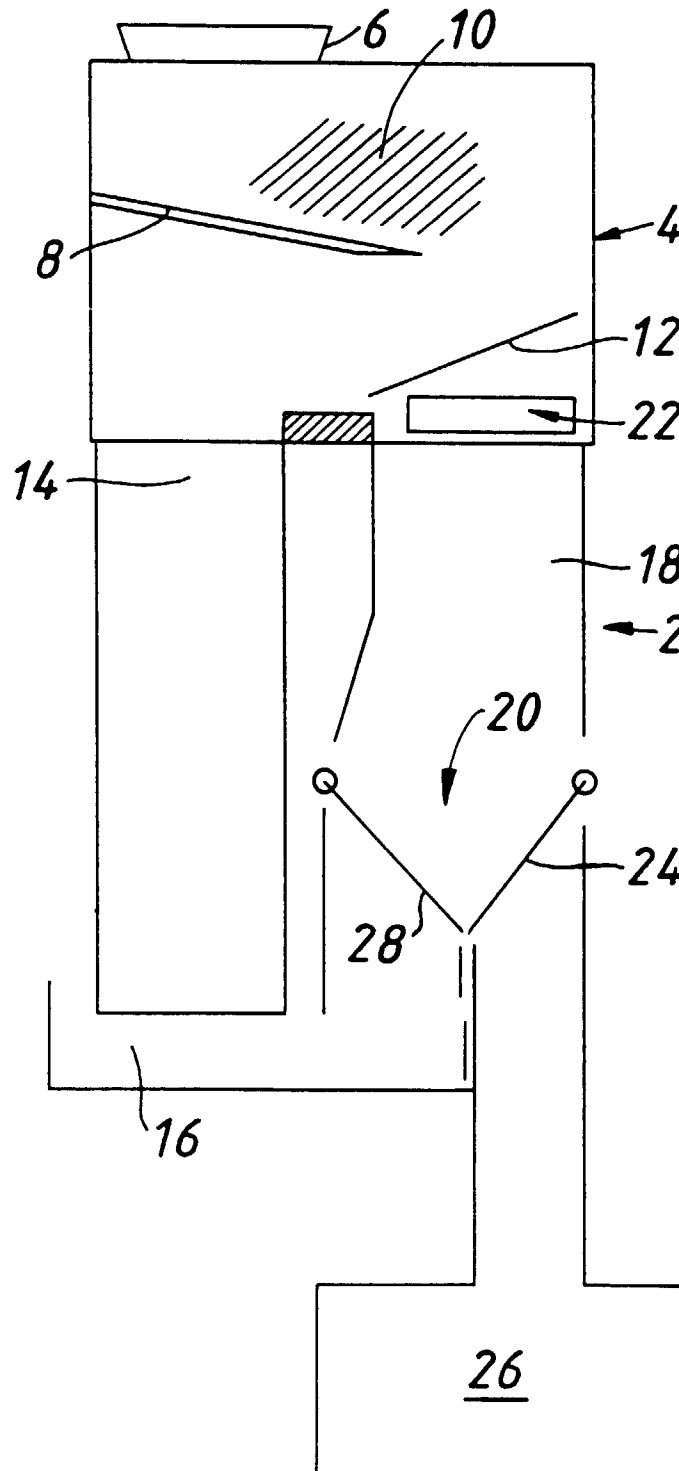

FIG. 2.

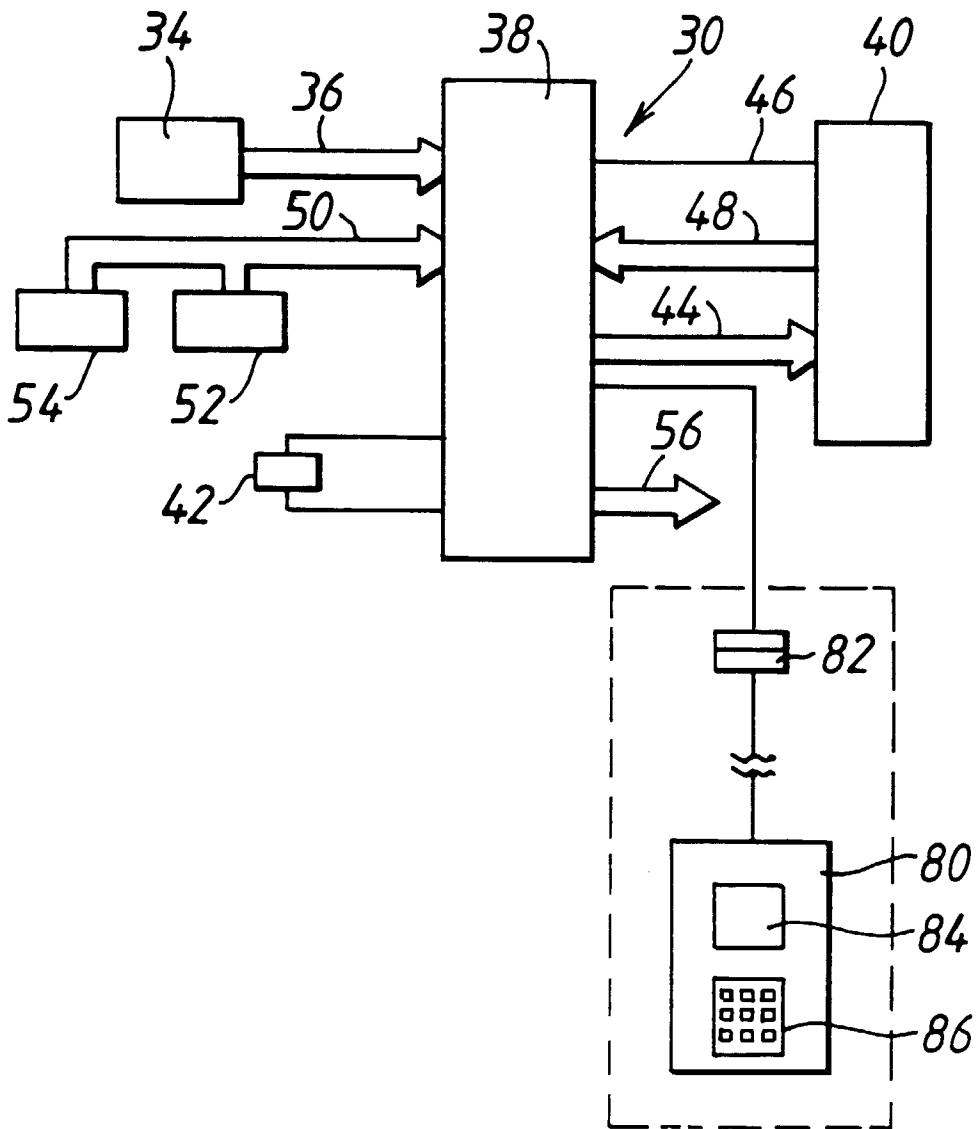

FIG. 3.

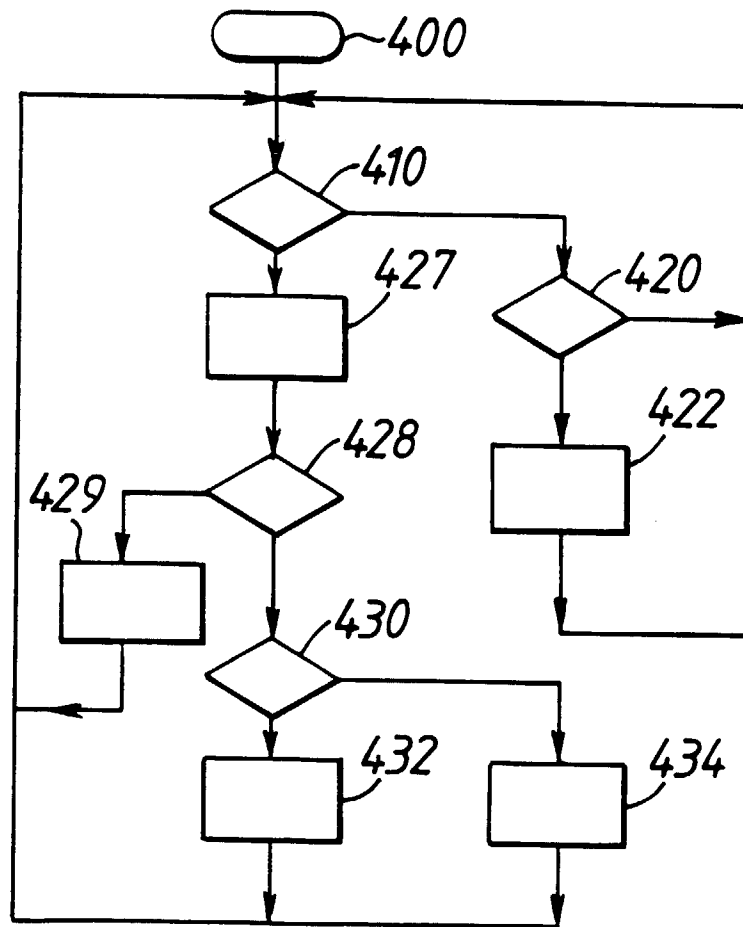

FIG. 4.

