

(19) World Intellectual Property Organization
International Bureau



(43) International Publication Date
9 October 2003 (09.10.2003)

PCT

(10) International Publication Number
WO 03/082389 A1

(51) International Patent Classification⁷: **A61M 15/00**

(21) International Application Number: PCT/GR02/00050

(22) International Filing Date:
25 September 2002 (25.09.2002)

(25) Filing Language: English

(26) Publication Language: English

(30) Priority Data:
20020100159 29 March 2002 (29.03.2002) GR

(71) Applicant and

(72) Inventor: **PENTAFRAGAS, Dimitrios** [GR/GR]; 17
Elaionon Street, GR-190 09 Pikermi Attika (GR).

(74) Agent: **PAPACONSTANTINO, Helen, G.**; 2 Coumbari
Street, GR-106 74 Athens (GR).

(81) Designated States (*national*): AE, AG, AL, AM, AU, AZ, BA, BB, BG, BR, BY, BZ, CA, CN, CO, CR, CU, DM, DZ, EC, EE, GD, GE, GH, GM, HR, HU, ID, IL, IN, IS, JP, KE, KG, KP, KR, KZ, LC, LK, LR, LS, LT, LV, MA, MD, MG, MK, MN, MW, MX, MZ, NO, NZ, OM, PH, PL, RO, RU, SD, SE, SG, SI, SL, TJ, TM, TN, TT, TZ, UA, UG, US, UZ, VC, VN, YU, ZA, ZM, ZW.

(84) Designated States (*regional*): Eurasian patent (AM, AZ, BY, KG, KZ, MD, RU, TJ, TM), European patent (AT, BE, BG, CH, CY, CZ, DE, DK, EE, ES, FI, FR, GB, GR, IE, IT, LU, MC, NL, PT, SE, SK, TR).

Published:
— with international search report

For two-letter codes and other abbreviations, refer to the "Guidance Notes on Codes and Abbreviations" appearing at the beginning of each regular issue of the PCT Gazette.

(54) Title: DRY POWDER INHALER

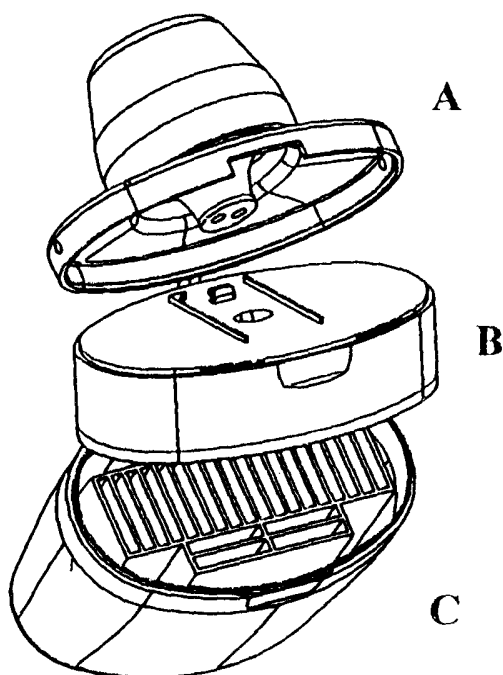

(57) Abstract: An inhalation device for the uptake of medicaments that are in the form of dry powder contained in the blisters of specially designed single dose blister strips. The device is comprised of a mouthpiece (A), a strip support surface area (B), and one or more storage areas (C). Furthermore, the single dose blister strip is described. It is comprised of two sheets (17, 20) that are fixed in such a manner so that when they get separated the powder becomes available for inhalation.



WO 03/082389 A1

Dry Powder Inhaler

5 The present invention refers to an inhaler for the uptake of medicaments in the form of dry powder and to specially designed single dose blister strips that are used with the said inhaler.

The inhaling devices currently used can be separated into two categories:

10 1. Those where the pharmaceutical powder is stored in a container out of which a measured amount of powder can be released via specific mechanisms. EP0069715 for example, describes a device in which the powder is metered in given dosages through apertures located in a rotatable disc, these apertures being introduced into an airduct or channel through which air is inhaled, by rotating the disc.

15 2. Those where measured amounts of pharmaceutical powder can be stored separately in special containers. GB2242134 for example, describes a device which uses a flexible strip defining a plurality of pockets each of which contains a dose of medicament which can be inhaled. The device contains a chamber in which the strip is housed, an opening station which contains means for peeling the two sheets or the strip apart, and an outlet through which the user can inhale the medicament.

20 The major disadvantages of these and other similar devices are that a. the user cannot visually verify whether he has received the entire dose of the medicament, and b. they function through complicated internal mechanisms.

25 The advantage of the present invention is that the user can visually check the presence of the medicament in the blister of the strip prior to inhalation and verify after the inhalation that he has received the entire dose of the medicament. Additionally, the device is simple to manufacture and easy to operate.

30 The device of the present invention is comprised of three parts: the mouthpiece, through which the powder is inhaled, the blister strip support surface and the strip storage compartment(s), which house(s) a large number of blister strips. The three parts are connected to each other and can be independently opened. The support surface contains an attachment point, where the blister strip is attached with the help of an attachment
35 formation; a cavity, which accommodates the blister of the strip; and strip guides, which secure the proper and firm placement of the strip on the surface.

The single dose blister strip is comprised of two sheets that can be peeled away from each other. The base sheet has a blister which contains the powder, and an attachment
40 formation which fits to the attachment point of the support surface. The cover sheet seals the base sheet only in the area around the blister.

The principle of use is that the user securely attaches the blister strip on the attachment surface, pulls away the cover sheet of the blister by exercising a slight force, checks the content of the blister, inhales the medicament, and finally verifies that he has received the
45 entire dose.

Figures 1-9 depict examples of the invention.

Figure 1 shows different views of an example of an inhaler.

Figure 2 shows the mouthpiece of the device along with its component parts.

Figure 3 shows the part of the device that contains the area on which the blisters are placed.

Figure 4 shows the blister storage compartment.

Figure 5 shows a single dose blister strip and the way it is put together.

5 Figure 6 shows the process that reveals the powder in the blister.

Figure 7 shows the flow of air and powder during the inhalation process.

Figures 8 and 9 are further examples of inhalers based on the principle of the present invention.

10 The inhaler (Figure 1) includes 3 basic parts, the mouthpiece **A** with its cover, part **B** with the surface on which the blister strip is placed, and the blister strip storage part **C**. The parts are connected to each other and can be opened independently.

15 The mouthpiece (Figure 2) is comprised of parts 1, 2 and 3. Part 1 locks in part 2 and part 2 locks in part 3.

Part 1 is the external part of the mouthpiece, and may have air openings at its base.

20 Part 2 is a cylinder with a wider base. The top of the cylinder has an opening 4, which serves as the exit of the powder from the device. Inside the cylinder there is formation 5, which may be of helical or other shape, through which the inhaled powder containing air exits the device. The end of formation 5 at the base of part 2 is blocked in half with surface 6.

25 Part 3 is also a cylinder, which has a wider top. The interior of part 3 is divided in chambers 7 and 8, by an upright flat surface 9. The base of part 3 touches the blister. It has two holes, 10 and 11, one on each side of dividing part 9. Hole 11 may contain a sieve, in order to block the passage of larger particles. Chamber 7 contains hole 10, and is blocked at its top with surface 6. Furthermore, chamber 7 contains hole 12, which serves as the air entrance.

30 The single dose blister strip is placed on the attachment surface of part **B** (Figure 3). This surface has a protrusion 13 that serves as the attachment point, a cavity 14 which receives the blister of the strip, and a system of strip guides, 15 and 16 in the specific example. The protrusion, the cavity and the guides enable the correct alignment of the strip on the surface of part **B** and secure its firm placement during the use of the device.

35 The lower portion of part **B** can be used as a storage compartment for the blister strips.

The strip storage part **C** (Figure 4) can be of various shapes, and may contain a grid, depending on the number of strips it accommodates, e.g. 30 or 60.

40 The blister strip (Figure 5) consists of two sheets (Figure 5A) made of suitable material e.g. PVC, aluminium, polyamide, paper, polyester, vinyl gum. One of the two sheets is the base sheet 17, which has the blister 18 that contains the powder, and the attachment hole 19. The other is the cover sheet 20 that is fixed to the base sheet, e.g. by heat adhesion, and air-tightly seals only the area around blister 18, as shown in the drawing (Figure 5B, darkened area). Sheet 20 is then folded by a 180-degree rotation around axis 45 **DE**, revealing hole 19 and covering the flat surface of blister 18 (Figure 5C).

The process by which the blister-contained powder is exposed takes place in two stages (Figure 6).

During the first stage (Figure 6A) and while the mouthpiece is open, the user secures the strip on the support surface of part **B** by placing hole **19** around protrusion **13**. Blister **18** is then placed in cavity **14** with the assistance of guides **15** and **16**.

5 During the second stage (Figure 6B), the user closes the mouthpiece and pulls cover sheet **20** towards the direction of the arrow until it is completely detached.

At this point and after lifting the mouthpiece, the user can verify that the powder contained in blister **18** has been revealed and is available for inhalation (Figure 6C). The user then just closes the mouthpiece and inhales. Finally, by opening again the
10 mouthpiece, he can visually check whether he has inhaled the medicament.

During the process of inhalation (Figure 7) the air that is breathed-in enters the mouthpiece via the air openings, and then enters chamber **7** through hole **12**. From there on and passing through hole **10**, the air carries along the powder which is located in
15 blister **18** and passing through hole **11** brings it to chamber **8**. From there and through formation **5**, the powder exits the device.

Another example of the invention is shown in Figure 8. The attachment point for the blister strip on surface **B** is cavity **21**. The mouthpiece **A** contains projection **22** which,
20 when said mouthpiece is closed, enters cavity **21** and in this way secures the blister. In this case, the blister is placed on surface **B** with hole **19** above cavity **21**. Alternatively, blister strip hole **19** could be replaced by a cavity.

Figure 9 shows another embodiment of the invention. In this case, the attaching
25 component of the blister strip is formation **23** that is placed in the openings **24** of guides **15** and **16** of surface **B**.

It is obvious that there may be variations relating to the shape and the positions of the attachment point, the cavity and the guides on surface **B**, which can achieve appropriate
30 and secure attachment of the blister. All these different embodiments are also included in the scope of the present invention.

A further embodiment of the inhaler would include its use through the nose. This could
35 be achieved by substituting the mouthpiece with the appropriate attachment.

40

45

50

CLAIMS

1. An inhalation device for the uptake of medicaments in the form of dry powder, which is characterized by the use of single dose blister strips, and in that it includes a mouthpiece (A) through which the powder is inhaled, a part (B) with a support surface on which the blister strip is placed in such a manner as to remain securely attached, and a strip storage compartment (C).
2. An inhalation device according to claim 1, characterised in that the mouthpiece is comprised of three parts (1, 2, 3) which are lockable to each other.
3. An inhalation device according to claim 1 characterised in that the mouthpiece contains a projection (22).
4. An inhalation device according to claim 1 characterised in that the blister strip support surface includes an attachment point (13, 21, 24), a cavity (14) which accommodates the blister and strip guides (15, 16).
5. An inhalation device according to claim 1, characterised in that the single dose blister strip is comprised of a base sheet (17) and a cover sheet (20), which can be separated from each other.
6. An inhalation device according to claim 5, characterised in that the base sheet (17) defines a blister (18) that contains the powder and an attachment formation (19, 23), and in that the cover sheet (20) air-tightly seals the base sheet only in the area of the blister (18).
7. An inhalation device according to claim 5, characterized in that the exposure of the powder takes place by pulling away the cover sheet (20) from the base sheet (17).
8. A single dose medicament pack for use with a dry powder inhalation device, which is characterized by a base sheet (17) and a cover sheet (20), said sheets being air tightly sealed to one another, in that said base sheet (17) defines a powder containing blister (18) and an attachment formation (19, 23), and in that the cover sheet (20) covers the base sheet around the blister and can be detached from the base sheet.
9. A blister strip support surface (B) for a dry powder inhalation device, characterized by an attachment point (13, 21, 24), a cavity (14) which accommodates the blister and strip guides (15, 16).

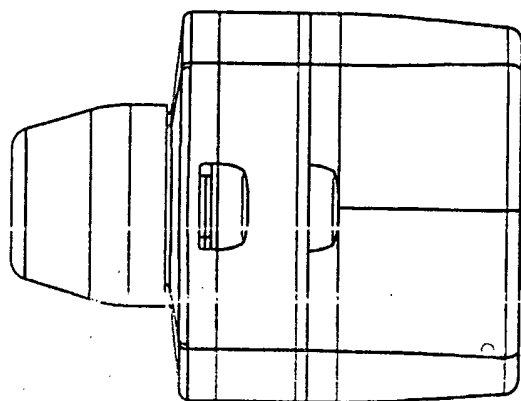
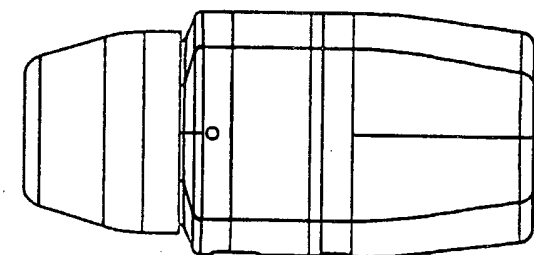
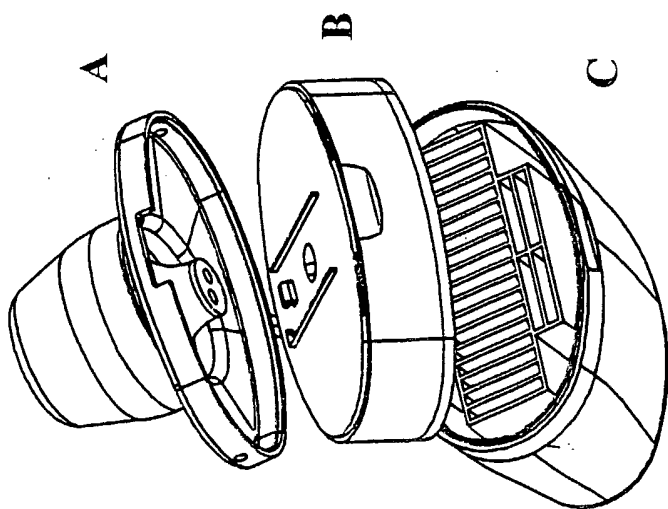

Figure 1

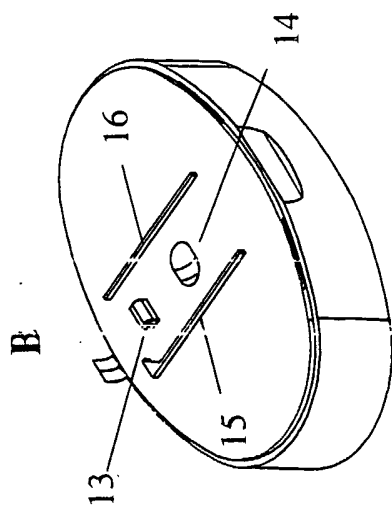
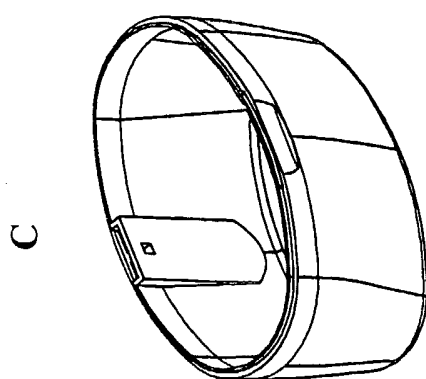
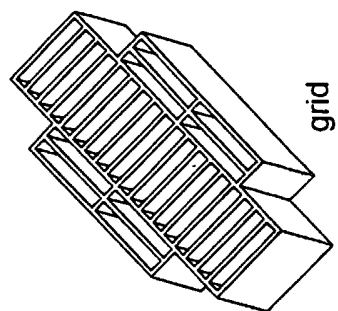

Figure 4

Figure 3

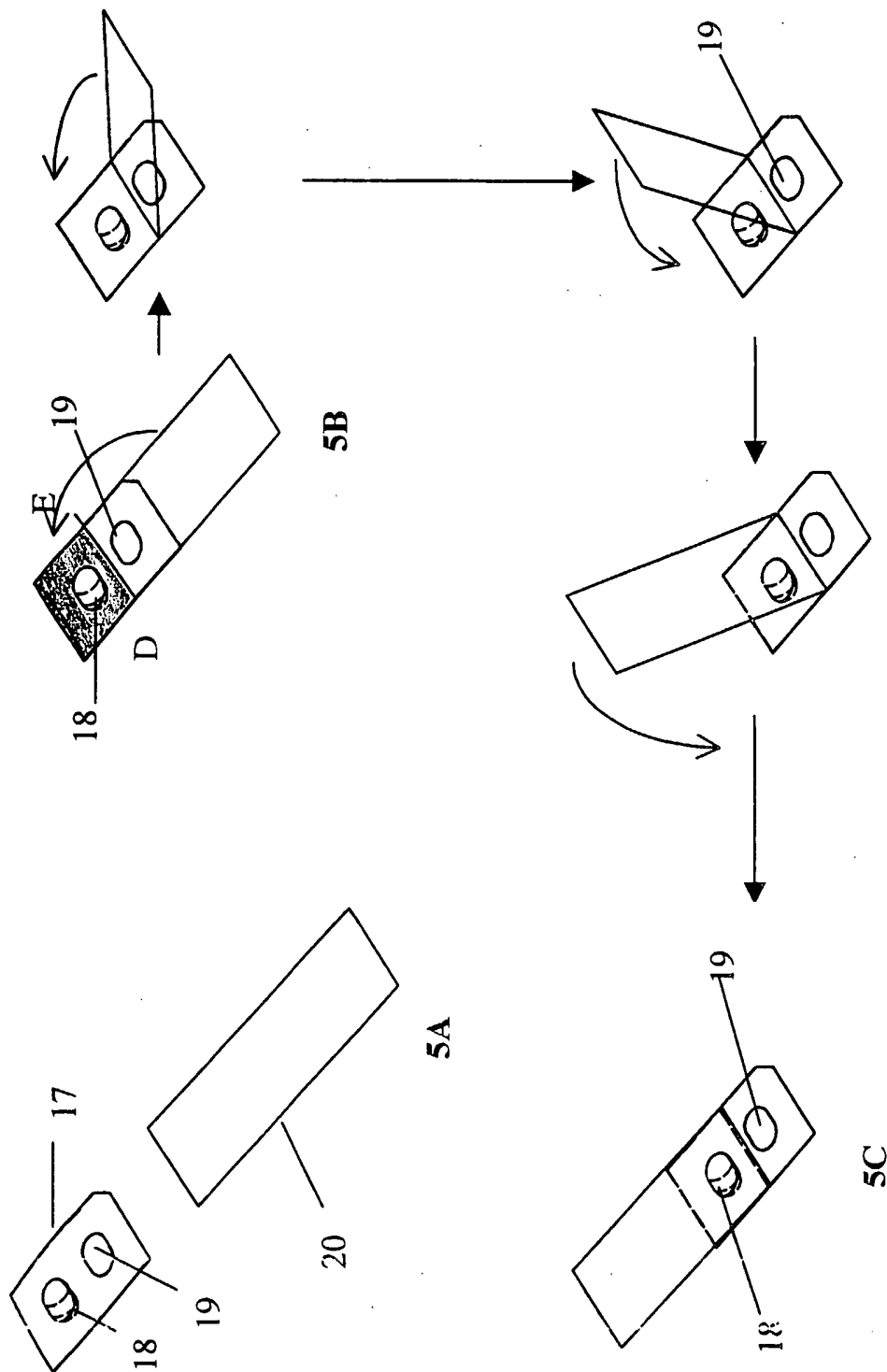
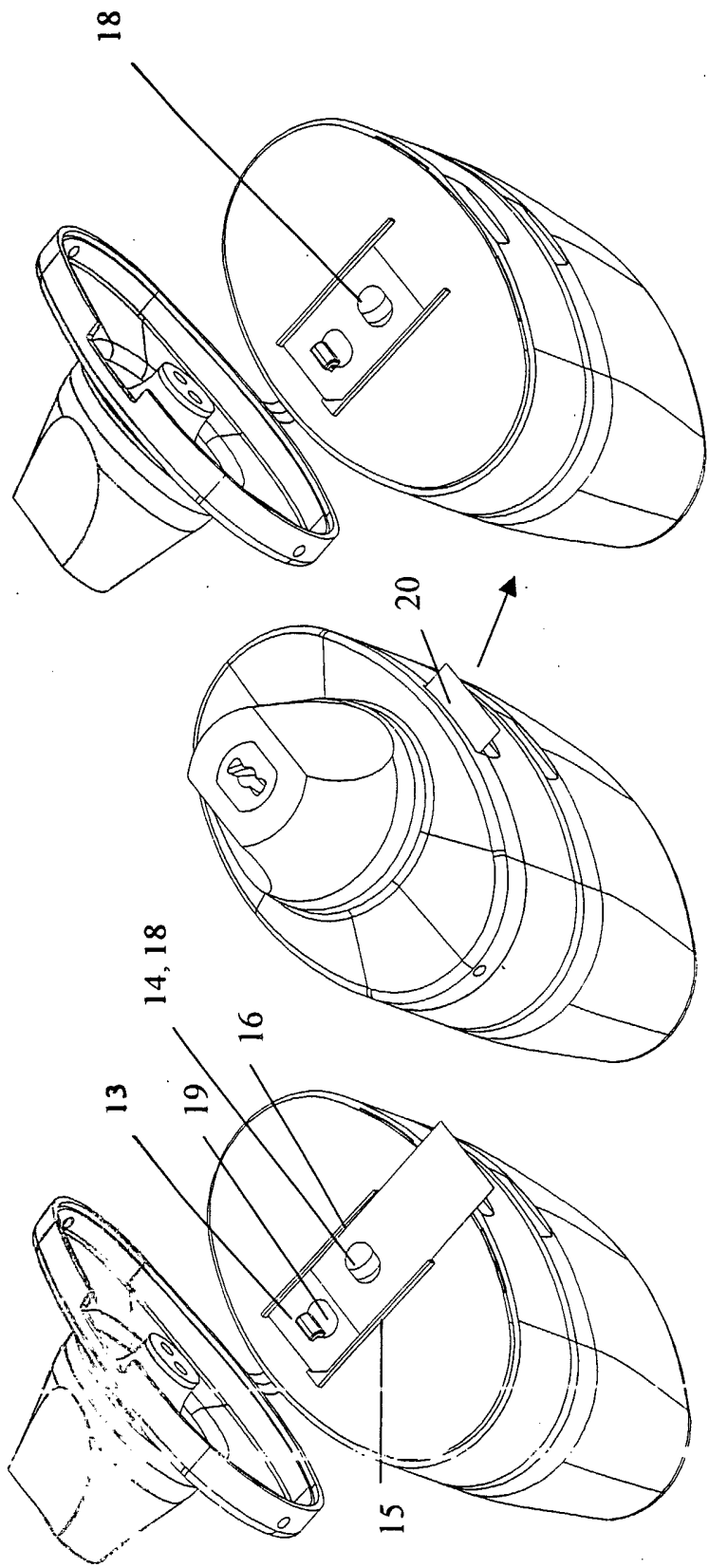

Figure 5



6A

6B

6C

Figure 6

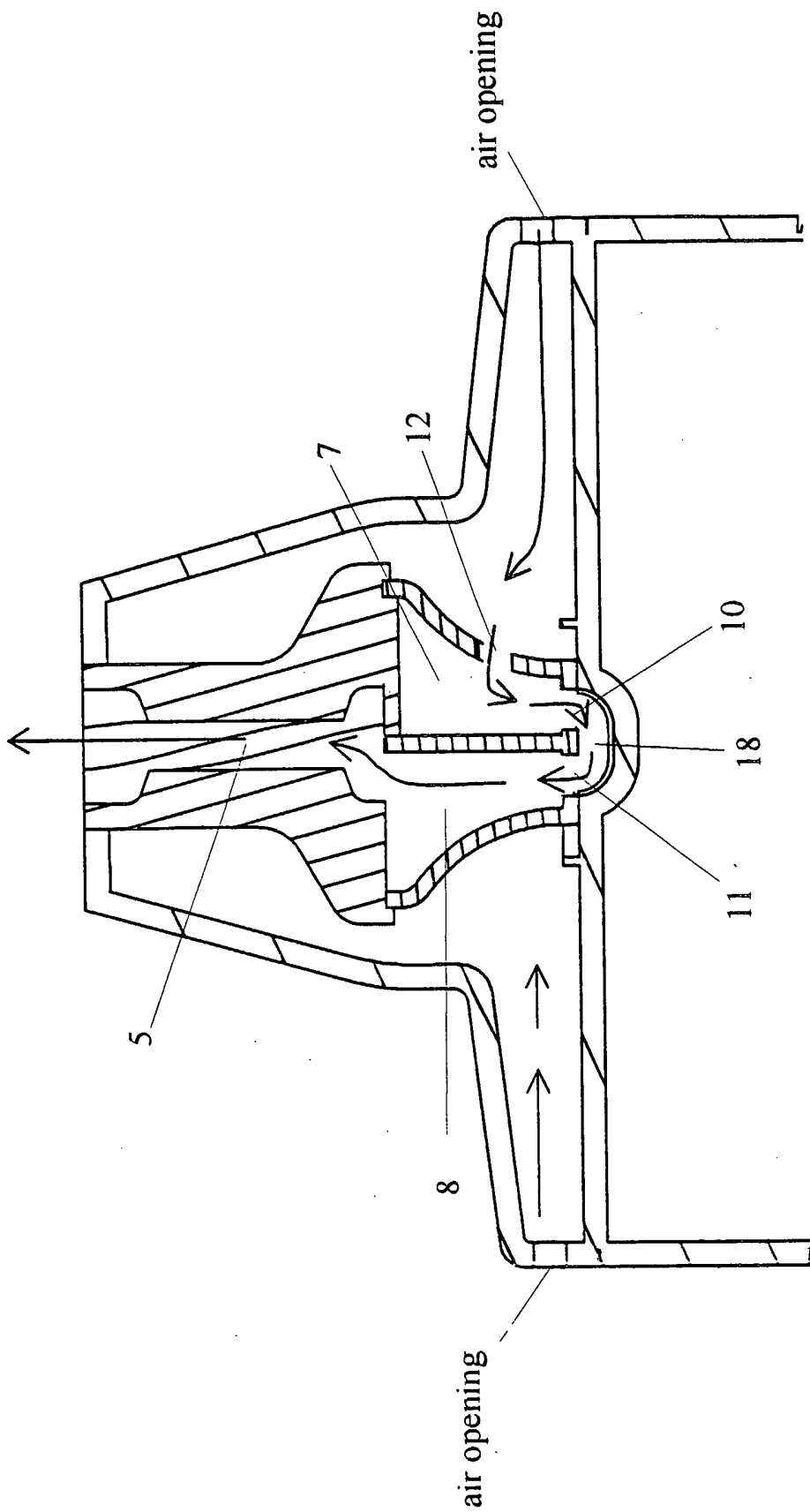

Figure 7

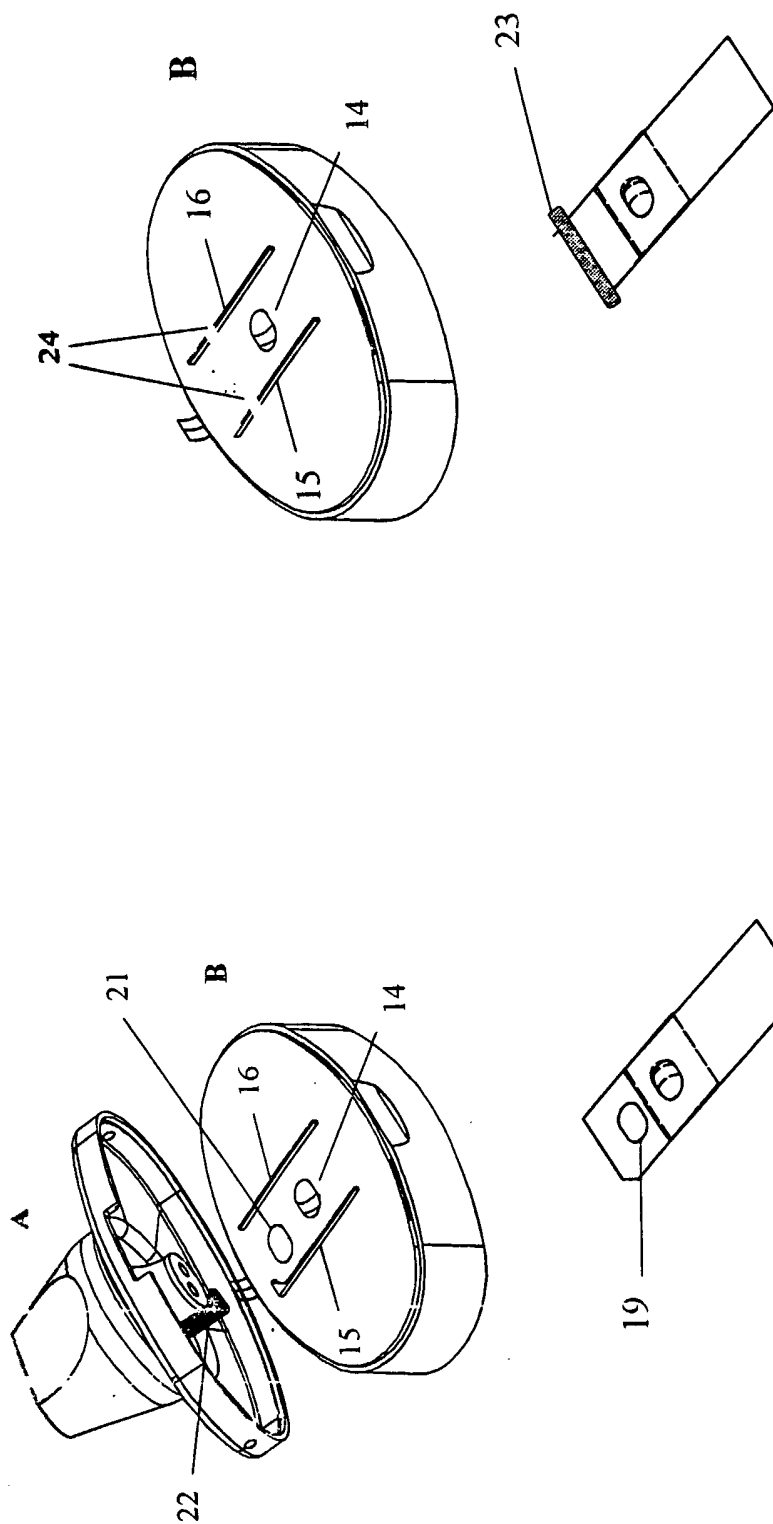

Figure 8

Figure 9

INTERNATIONAL SEARCH REPORT

International Application No
PCT/GR 02/00050

A. CLASSIFICATION OF SUBJECT MATTER
IPC 7 A61M15/00

According to International Patent Classification (IPC) or to both national classification and IPC

B. FIELDS SEARCHED

Minimum documentation searched (classification system followed by classification symbols)
IPC 7 A61M

Documentation searched other than minimum documentation to the extent that such documents are included in the fields searched

Electronic data base consulted during the international search (name of data base and, where practical, search terms used)

EPO-Internal

C. DOCUMENTS CONSIDERED TO BE RELEVANT

Category °	Citation of document, with indication, where appropriate, of the relevant passages	Relevant to claim No.
X	EP 0 129 985 A (GLAXO GROUP LTD) 2 January 1985 (1985-01-02) page 5, line 20 -page 6, line 12; figure 7	1,3-5,9
Y	page 5, line 29 - line 33 ---	6,7
X	WO 00 64779 A (BONNEY STANLEY GEORGE ;DAVIES MICHAEL BIRSHA (GB); GODFREY JAMES W) 2 November 2000 (2000-11-02) page 10, line 11 - line 24; figure 1	8
Y	page 12, line 12 - line 18; figures 3C,4A,4B ---	6,7
X	WO 98 34663 A (WIDERSTROEM CARIN ;ASTRA AB (SE)) 13 August 1998 (1998-08-13) page 7, line 4 - line 19; figure 8 -----	1

Further documents are listed in the continuation of box C.

Patent family members are listed in annex.

° Special categories of cited documents :

- *A* document defining the general state of the art which is not considered to be of particular relevance
- *E* earlier document but published on or after the international filing date
- *L* document which may throw doubts on priority claim(s) or which is cited to establish the publication date of another citation or other special reason (as specified)
- *O* document referring to an oral disclosure, use, exhibition or other means
- *P* document published prior to the international filing date but later than the priority date claimed

- *T* later document published after the international filing date or priority date and not in conflict with the application but cited to understand the principle or theory underlying the invention
- *X* document of particular relevance; the claimed invention cannot be considered novel or cannot be considered to involve an inventive step when the document is taken alone
- *Y* document of particular relevance; the claimed invention cannot be considered to involve an inventive step when the document is combined with one or more other such documents, such combination being obvious to a person skilled in the art.
- * & * document member of the same patent family

Date of the actual completion of the international search

5 December 2002

Date of mailing of the international search report

20/12/2002

Name and mailing address of the ISA

European Patent Office, P.B. 5818 Patentlaan 2
NL - 2280 HV Rijswijk
Tel. (+31-70) 340-2040, Tx. 31 651 epo nl,
Fax: (+31-70) 340-3016

Authorized officer

Valfort, C

INTERNATIONAL SEARCH REPORT

Information on patent family members

International Application No

PCT/GR 02/00050

Patent document cited in search report		Publication date	Patent family member(s)	Publication date
EP 0129985	A	02-01-1985	AT 36965 T	15-09-1988
			AU 569743 B2	18-02-1988
			AU 2852384 A	29-11-1984
			CA 1238251 A1	21-06-1988
			DE 3473834 D1	13-10-1988
			DK 253584 A	25-11-1984
			EP 0129985 A1	02-01-1985
			ES 8600947 A1	16-02-1986
			FI 842052 A ,B,	25-11-1984
			GB 2142246 A ,B	16-01-1985
			IE 55508 B1	10-10-1990
			IL 71852 A	31-08-1988
			IN 163009 A1	30-07-1988
			JP 59225070 A	18-12-1984
			KR 9104328 B1	26-06-1991
			MY 86187 A	31-12-1987
			NO 842049 A ,B,	26-11-1984
			NZ 208256 A	31-03-1987
			ZA 8403878 A	24-12-1984
			WO 0064779	A
WO 0064779 A1	02-11-2000			
EP 1173368 A1	23-01-2002			
WO 9834663	A	13-08-1998	AU 6009098 A	26-08-1998
			EP 0973570 A1	26-01-2000
			WO 9834663 A1	13-08-1998