

Sept. 2, 1958

I. SPINNER

2,850,341

TABLE AND RACK FOR BINDING APPARATUS

Filed Sept. 13, 1954

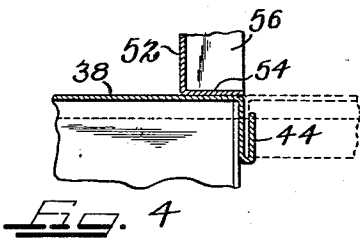
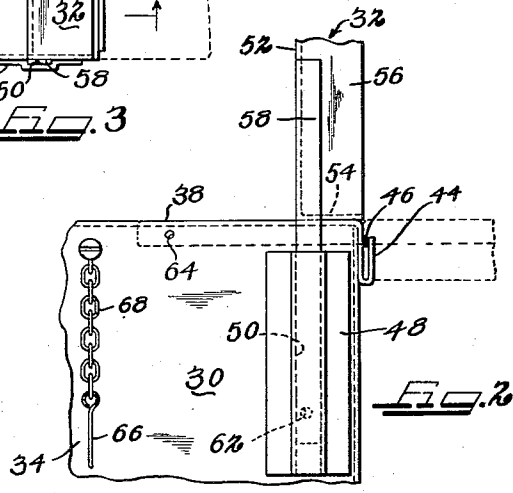
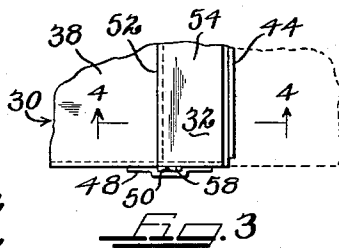
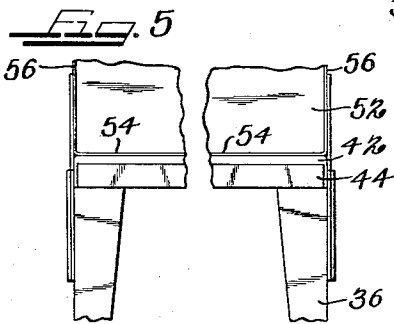
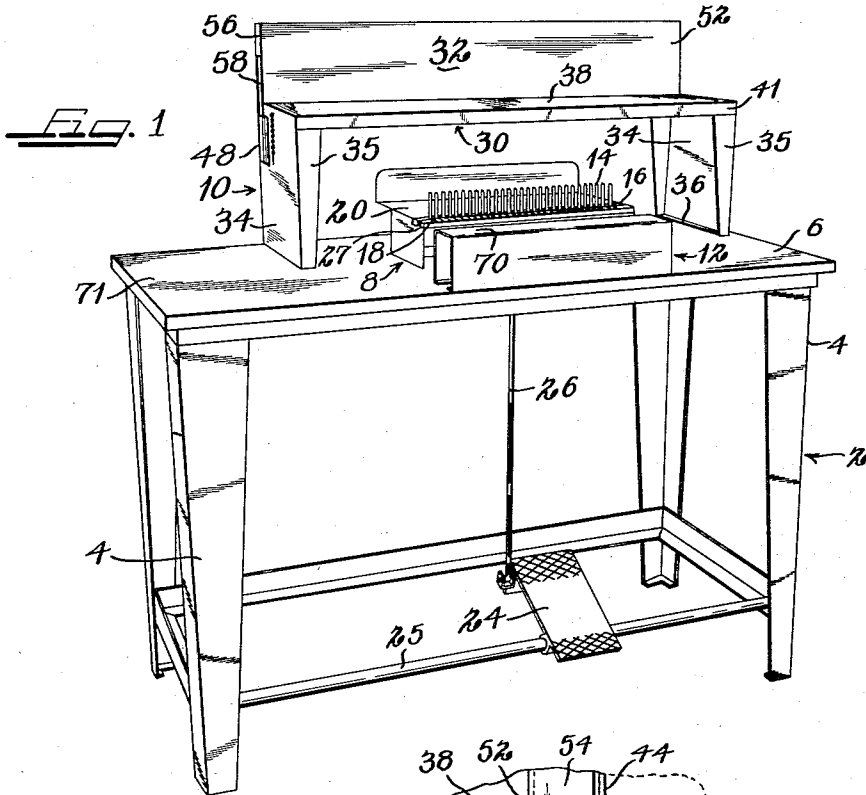

INVENTOR
ISIDORE SPINNER

Morris Spector
ATTORNEY

1

2,850,341

TABLE AND RACK FOR BINDING APPARATUS

Isidore Spinner, Chicago, Ill.

Application September 13, 1954, Serial No. 455,637

3 Claims. (Cl. 311—3)

This invention relates to apparatus for use in binding books, pamphlets, or other assemblies of slotted sheets by means of tubular binders consisting of a number of resilient, normally curled teeth or rings extending from a common backing.

The invention deals more particularly with the arrangement and construction of shelving for supporting unbound slotted sheets of varying sizes in positions where they can be conveniently grasped and placed in position to receive the tubular binders held in uncurled position on a binder inserter device.

An object of this invention is to provide a work supporting shelf structure which is usable in conjunction with a binder inserter, wherein the shelf has a movable section which may be positioned in a vertical direction to act as a retaining wall at the rear of the shelf and, further, wherein the movable section may be either removed completely from the shelf structure or may be mounted so that its top surface is flush with the rest of the shelf to provide a larger supporting area for slotted sheets which cannot be otherwise accommodated by the shelf structure.

A further object of this invention is to provide a shelf structure of the above character which is of economical construction and which can support heavy loads.

The attainment of the above and further objects of the invention will be apparent from the following specification taken in conjunction with the accompanying drawings forming a part thereof.

In the drawings:

Fig. 1 is a perspective view of the apparatus making up the preferred form of the invention;

Fig. 2 is an enlarged fragmentary side view of a portion of the shelf structure, with the alternate position of the movable shelf section shown in dotted lines;

Fig. 3 is a fragmentary top view of the shelf structure shown in Fig. 2;

Fig. 4 is a fragmentary sectional view of the shelf structure taken along section line 4—4 in Fig. 3; and

Fig. 5 is a rear view of the shelf structure.

Reference should now be made to the drawings where like reference numerals indicate similar elements throughout.

The invention includes a work table 2 having legs 4 and an elevated table top or platform 6 on which is supported a binder inserter 8, a shelf structure 10 for supporting stacks of unbound sheets, and an inverted channel-shaped member 12 for supporting partially bound sheets extending from the inserter.

The arrangement and construction of the various aforementioned elements are such that large or small unbound sheets of material may be stacked in positions which are readily accessible to the operator of the inserter 8, so that a minimum of time is required to grasp a group of slotted sheets to be bound, arrange them so that their slots are in registry, and then place them in a position on the inserter where the curled resilient rings

2

or teeth of a comb-shaped binder are threaded through the slots of the sheets.

The inserter 8 may be of any suitable type as, for example, one having a row of binder support pins 14 extending up from a longitudinally movable, elongated block 16, and a series of laterally movable binder ring engaging hooks 18 aligned in a row in front of the binder support pins 14. Space is provided in a tray section 20 behind the support pins for storing a number of binders in a position where they may be grasped and quickly inserted in position against the binder support pins 14. The backbone of a binder is braced against the rear of the pins 14 with the curled binder rings extending forward between the pins 14. In this position the hooks 18 are between the binder rings.

The inserter 8 is operated by a foot pedal 24 pivoted on a rod 25 extending between the front legs 4 of the table 2. A connecting rod 26 extends between the end of the foot pedal 24 and suitable mechanism within the inserter 8. The elongated block 16 is manually moved longitudinally so that the hooks 18 enter the binder rings. Depression of the foot pedal 24 then pulls the rod 26 down, which in turn causes the binder ring engaging hooks 18 to move away from the binder support pins 14 so as to uncurl the binder rings. An inserter which operates in this manner is disclosed in co-pending application Serial No. 406,570, filed January 27, 1954.

In accordance with the invention, the shelf structure 10 is so constructed and located that stacks of small or large unbound sheets are readily accessible to the operator so that a minimum of time is required to bind a given number of sheets. The shelf structure 10, illustrated in the drawings, is constructed of two sheet metal pieces 30 and 32. The sheet metal piece 30 is shaped and bent into a shelf structure having two longitudinally spaced, rectangular, vertical end walls 34 with narrow, vertically extending strengthening flanges 35 at its front and rear edges and inwardly turned, horizontal seating flanges 36 at the bottom of said end walls, which seating flanges rest on the table top 6. The end walls 34 and the associated flanges constitute supporting legs for the raised rectangular shelf or platform 38 formed by the main body of the sheet metal piece 30. The shelf 38 has a horizontal top surface which merges with the top of the end walls 34. A narrow flange 41 depends from the front edge of the shelf 38 and overlies the top of the front vertical leg flanges 35. A narrow flange 42 depends from the rear of the shelf 38 and overlies the rear vertical leg flanges 36. The bottom of the flange 42 is curved rearwardly and vertically upwardly at 44 to define a narrow, vertical, open-top channel or slot 46 (Fig. 2), the function of which will be explained later.

A pair of vertically extending channel members 48 are welded or otherwise secured to the outer surfaces of the end walls 34 adjacent the upper, rear edges thereof. The tops of the channel members 48 are spaced a small distance below the top of the shelf 38. A vertical, open-top guideway 50 having walls on all sides thereof is defined between the channel members 48 and the end walls 34. The channel members are spaced forward of the rear edge of the end walls 34.

The other sheet metal piece 32 of the shelf assembly is adapted to be orientated vertically along the rear edge of the shelf 38 to form a rear retaining wall for the shelf, as shown in solid lines in the drawings, or, alternatively, may be orientated horizontally flush with the shelf 38, as shown in dotted lines in the drawings, to form a rear shelf section to increase the overall shelf area of the shelf structure.

The sheet metal piece 32 has a rectangular central sec-

tion 52 whose peripheral regions have been bent into the same direction to form two longitudinal flanges 54 and two end flanges 56, which flanges are in planes at right angles to the central section 52 of the sheet metal piece. The width of the flanges is made equal to the distance between the top of the shelf 38 and the bottom of the longitudinal channel 46 at the rear of the shelf 38 for reasons which will be explained. The overall length of the sheet metal piece 32 is equal to the distance between the outer surfaces of the end walls 34 of the other sheet metal piece 30.

A pair of rectangular metal strips 58 are welded or otherwise secured to the respective end flanges 56 of the sheet metal piece 32. The strips are flush with the central section 52 and extend beyond one of the longitudinal flanges 54 and at right angles thereto to form tongues which are adapted to be received within the guideways 50 at the sides of the vertical end walls 34, to support the sheet metal piece in a vertical direction. The widths of the tongues or strips 58 are made less than the distance from the top of the channel members 48 to the top of the shelf 38 for reasons to be explained. Also, the forwardmost defining walls of the guideways 50 are spaced forward of the rear edge of the end walls a distance substantially equal to the widths of the longitudinal flanges 54 of the sheet metal piece 32.

Where small or average sized sheets are to be bound by the binder-inserting device 8, the sheet metal piece 32 is orientated in a vertical direction so that the central piece 52 thereof extends upwardly from the rear of the shelf 38, as shown in solid lines in the drawings. In this position, the piece 32 forms a retaining wall for the stacks of sheets to be supported on the shelf 38, and the retaining wall helps to maintain the alignment of the sheets which are stacked thereon. To secure the sheet metal piece 32 in position on the shelf 38, the piece 32 is orientated in a vertical direction with the projecting ends of the tongues 58 pointing downward and the flanges of the piece facing rearwardly of the table 2. The sheet metal piece 32 is then lowered into a position such that the tongues 58 extend into the guideways 50 formed between the channel members 48 and the end walls 34. The downward movement of the sheet metal piece 32 comes to a halt as the bottom longitudinal flange 54 engages the top of the shelf 38. In this position, the rear of the piece 32 defined by the edges of the longitudinal flanges 54 are flush with the rear edge of the end walls 34. The tongues 58 extend an appreciable distance within the guideways 50 and thus the sheet metal piece 32 is braced securely in a vertical position.

When unusually large sheets of material are to be bound, the sheet metal piece 32 is secured in a horizontal position and flush with the shelf 38, so as to increase the overall shelf area. In this position, the piece 32 becomes a rear shelf section. To secure the sheet metal piece 32 in this position, the piece is orientated so that the central portion 52 thereof is in horizontal plane with the flanges thereof projecting downwardly and the tongues 58 projecting forwardly. The piece is then lowered into position so that the forwardmost longitudinal flange 54 extends into and rests on the bottom of the channel 46 formed by the upturned end of the rear shelf flange 42. Since the width of the flange 54 was made equal to the distance between the top of the shelf 38 and the bottom of the channel 46, the top of the central portion 52 of the piece 32 will then be flush with the top of the shelf 38. To enable the piece 32 to assume this position, the length of the upturned portion 44 of the rear shelf flange 42 must be slightly less than the distance between the inner faces of the end flanges 56 of the sheet metal piece 32. Otherwise, the sheet metal piece could not fit over the upturned edge 44 since the bottom of the end flanges 56 would rest on the top of the upturned flange portion 44 and thereby prevent the flange 54 from entering the slot 46.

Since the width of the tongues 58 were made less than the distance between the top of the guide-forming members 48 and the top of the shelf 38, the tongues extend freely above the members 48 when the piece 32 is in the aforementioned horizontal position. The sheet metal piece 32 is thus cantilevered from the rear of the sheet metal piece 30, and it is therefore desirable to provide additional means for securing the sheet metal piece 32 in place. To this end, holes 62 are formed in the ends of the tongues 58 and holes 64 are formed in the end walls 34 of the sheet metal piece 30. The apertures 62 and 64 are in registry when the sheet metal piece 32 is supported within the horizontally extending channel 46. A securing pin 66 is connected to the end of a chain 68 anchored to each of the end walls and each pin 66 is extended through one of the aligned pairs of holes 62 and 64 to anchor the sheet metal piece 32 to the sheet metal piece 30 when the former piece is orientated in its horizontal position.

The shelf assembly 10 is preferably made as a separate integral unit from the table 2 and the binder-inserting device 8. The shelf assembly is located on the top of the table 2 such that the rear of the end walls 34 thereof are flush with the rear edge of the table top 6. The left-hand end wall 34, viewed in Fig. 1, is spaced from the side edge of the table top a sufficient distance to leave a space 71 extending from the front to the rear edge of the table top on which the completed bound sheets may be placed following their removal from the binder-inserting device 8.

The table top 6 is so dimensioned that the front edge thereof is spaced from the front of the shelf assembly 10 a sufficient distance to accommodate most of the inserter 8 and the platform 12. If the shelf 38 overhung most of the inserter, access to the binders stored in the rear of the tray 20 would be blocked by the shelf 38. The shelf 38 is at an elevation which enables a person of ordinary height to reach the sheets supported on the shelf 38 from the front of the table 6.

In the binder-inserting device 8 shown in the drawings, the binder support pins 14 are located only a small distance from the front of the device. For reasons which will be soon explained, it has been found desirable to place a platform in front of the binder-inserting device 8. To this end, the channel-shaped member 12 is inverted and placed on the table top so that it provides a horizontal platform 70 elevated above the table top 6 and at approximately the same elevation as the top of the block 16 of the binder-inserting device. The channel member 12 is positioned a sufficient distance in front of the binder inserter 8 to enable the binder ring-engaging hooks 18 to be moved forwardly of the binder support pins 14 without interference from the channel member 12. This movement is, of course, appreciably smaller than the width of the sheets to be bound.

The width of the platform 70 formed by the channel member 12 is sufficient that it supports a group of sheets in a horizontal plane from the inserter. The platform 70 is used when the thickness of the sheets to be bound is so great that the binder fingers become wedged in the slots of the outermost sheets before they have extended completely through the group of sheets being bound. In order to completely extend the binder rings through the slots of the group of sheets being bound it is necessary to pivot the sheets through which the teeth have been extended from a vertical position in front of the fingers 14 of the inserter into a horizontal position so that the ends of the binder rings may be extended through the remainder of the vertically orientated sheets without interference. The platform 70 associated with the channel member 12 supports the partially bound sheets in the horizontal position.

The platform 70 also provides a convenient surface to align the sheets to be bound just prior to their insertion in the inserter.

5

In compliance with the requirements of the patent statutes I have here shown and described a preferred embodiment of my invention. It is, however, to be understood that the invention is not limited to the precise construction here shown, the same being merely illustrative of the principles of the invention. What I consider new and desire to secure by Letters Patent is:

1. A shelf structure for supporting unbound slotted sheets in a position to be quickly placed in position on a binder inserter, said shelf structure including a front shelf section in a sheet supporting position and a rear shelf section movable with respect to said front shelf section, means for supporting said rear shelf section in an upstanding position comprising respective tongues extending from the opposite sides of one of said shelf sections, guideway-forming members secured to the sides of the other shelf section and forming open-end guideways adapted to receive said tongues, and means for supporting said rear shelf in a sheet supporting position flush with the front shelf section comprising a U-shaped channel-forming member extending along one of the longitudinal edges of one of said shelf sections and a flange on the other self section adapted to extend into the channel of said latter member and engage the defining walls thereof.

2. A shelf structure for supporting unbound slotted sheets in a position to be quickly placed in position on a binder inserter device, said shelf structure including a shelf and a rear section movable with respect to said shelf, means for supporting said rear section in an upstanding position comprising a projecting tongue extending parallel to a sheet-supporting surface of the rear section, a guideway-forming member connected to the shelf and forming an open-top guideway adapted to receive said tongue, and means for supporting said rear section in a sheet-supporting position flush with said shelf comprising a U-shaped channel-forming member extending along the rear longitudinal edge of said shelf and below the top thereof, and a flange extending from the sheet-

6

supporting surface of said rear section and being of a depth equal to the distance between the top of said shelf and the bottom of the U-shaped channel of said channel-forming member.

3. A shelf structure having supporting legs and a rectangular shelf supported on said legs, a rear section behind and movable with respect to said shelf, said legs comprising a pair of longitudinally spaced, rectangular upstanding end walls depending from the sides of said shelf, said shelf having a flange which has an upturned end forming a U-shaped channel located below the top surface of said shelf, said rear section including a central sheet-supporting portion and a peripheral flange projecting at right angles from said central portion and having a depth equal to the distance from the top of said shelf to the bottom of said U-shaped channel, whereby said peripheral flange may extend into and engage said upturned flange and thereby support said rear section in a sheet-supporting position, said rear section including projecting portions which are adapted to straddle said end walls when said rear section is supported in a sheet-supporting position from the rear of said shelf, said projecting portions of said rear section and the end walls of said shelf having holes in registry with one another when said rear section is in said latter position, and respective pins adapted to extend through said holes to anchor said rear section in place to said shelf.

References Cited in the file of this patent

UNITED STATES PATENTS

292,657	Kirkpatrick	Jan. 29, 1884
1,609,355	Holle	Dec. 7, 1926
1,869,001	Allen	July 26, 1932
2,120,197	Adams	June 7, 1938
2,334,815	Emmer	Nov. 23, 1943
2,338,911	Emmer	Jan. 11, 1944
2,354,106	Cooper	July 18, 1944
2,377,432	Lear	June 5, 1945
2,415,604	Nalley	Feb. 11, 1947