



(51) International Patent Classification:

A61B 17/11 (2006.01) A61F 2/07 (2013.01)
A61F 2/06 (2013.01) A61B 17/00 (2006.01)
A61F 2/90 (2013.01)

(21) International Application Number:

PCT/US2015/028717

(22) International Filing Date:

1 May 2015 (01.05.2015)

(25) Filing Language:

English

(26) Publication Language:

English

(30) Priority Data:

61/987,954 2 May 2014 (02.05.2014) US
14/700,480 30 April 2015 (30.04.2015) US

(71) Applicant: **W.L. GORE & ASSOCIATES, INC.**
[US/US]; 555 Paper Mill Road, Newark, DE 19711 (US).

(72) Inventor: **TODD, Daniel, H.**; 17 Alicia Court, North East, MD 21901 (US).

(74) Agents: **MILLER, Amy** et al.; W.L. Gore & Associates, Inc., P.O. Box 9206, Newark, DE 19714-9206 (US).

(81) Designated States (unless otherwise indicated, for every kind of national protection available): AE, AG, AL, AM,

AO, AT, AU, AZ, BA, BB, BG, BH, BN, BR, BW, BY, BZ, CA, CH, CL, CN, CO, CR, CU, CZ, DE, DK, DM, DO, DZ, EC, EE, EG, ES, FI, GB, GD, GE, GH, GM, GT, HN, HR, HU, ID, IL, IN, IR, IS, JP, KE, KG, KN, KP, KR, KZ, LA, LC, LK, LR, LS, LU, LY, MA, MD, ME, MG, MK, MN, MW, MX, MY, MZ, NA, NG, NI, NO, NZ, OM, PA, PE, PG, PH, PL, PT, QA, RO, RS, RU, RW, SA, SC, SD, SE, SG, SK, SL, SM, ST, SV, SY, TH, TJ, TM, TN, TR, TT, TZ, UA, UG, US, UZ, VC, VN, ZA, ZM, ZW.

(84) Designated States (unless otherwise indicated, for every kind of regional protection available): ARIPO (BW, GH, GM, KE, LR, LS, MW, MZ, NA, RW, SD, SL, ST, SZ, TZ, UG, ZM, ZW), Eurasian (AM, AZ, BY, KG, KZ, RU, TJ, TM), European (AL, AT, BE, BG, CH, CY, CZ, DE, DK, EE, ES, FI, FR, GB, GR, HR, HU, IE, IS, IT, LT, LU, LV, MC, MK, MT, NL, NO, PL, PT, RO, RS, SE, SI, SK, SM, TR), OAPI (BF, BJ, CF, CG, CI, CM, GA, GN, GQ, GW, KM, ML, MR, NE, SN, TD, TG).

Published:

- with international search report (Art. 21(3))
- before the expiration of the time limit for amending the claims and to be republished in the event of receipt of amendments (Rule 48.2(h))

(54) Title: ANASTOMOSIS DEVICES

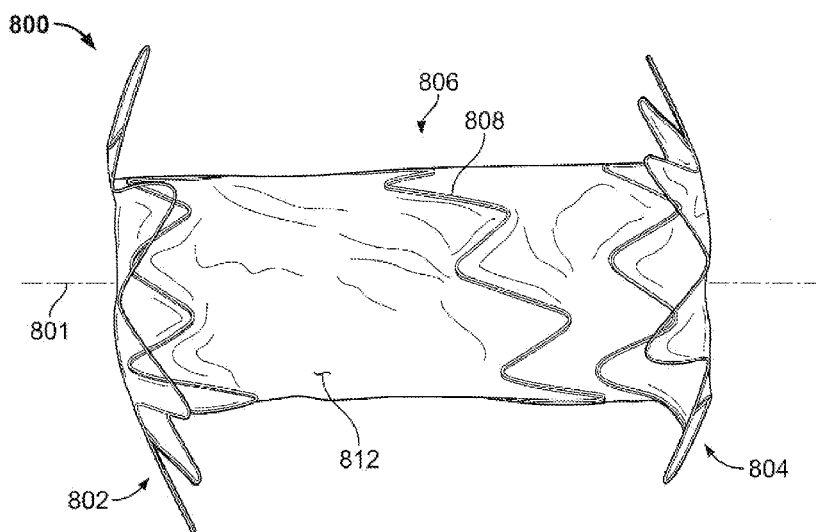

FIG. 2

(57) Abstract: Implantable medical devices (800) for connecting tissue layers or to circumvent occluded body conduits and tissue structures. The implantable medical devices include apposition portions (802, 804), a central region (806), and a covering material (812). The methods of using the devices include endoscopic deployment, and the devices may include self-expanding frameworks that facilitate a secure connection between the tissue structures. In some embodiments, one or more tethers (810 a, b, c) are used to longitudinally contract the device *in situ*.



ANASTOMOSIS DEVICES

FIELD

[0001] The present disclosure relates to implantable medical devices, and more specifically, to implantable devices for connecting tissue layers to create an anastomosis.

BACKGROUND

[0002] An anastomosis is a cross-connection between two tissue structures, such as blood vessels or intestines. For example, in the context of coronary artery bypass graft surgery, a graft vessel is anastomosed to a native coronary artery so that blood can flow through the graft vessel.

[0003] Anastomoses can be created in various manners including, but not limited to: end-to-end, end-to-side, and side-to-side anastomoses. Often, suturing is used to create such anastomoses.

SUMMARY

[0004] A first aspect of the invention relates to an implantable medical device that includes (1) a first apposition portion having a plurality of first apposition members, (2) a second apposition portion having a plurality of second apposition members, and (3) a central portion having at least one supported region and at least one unsupported region. The supported region includes a frame member and the unsupported region includes a covering material. The central portion interconnects the first and second apposition portions and is selectively longitudinally contractible. In some embodiments, the first apposition portion and the supported region includes a first elongate member and the second apposition portion includes a second elongate member. The unsupported region may consist of the cover material. In some embodiments, the first elongate member has a first stiffness and/or a first geometry and the second elongate member has a second stiffness and/or a second geometry that is different than the first stiffness and/or first geometry, respectively. In at least one embodiment, the first apposition portion, the supported region, and the second apposition member is formed of a single elongate member. The device may also include a tether affixed to one of the

first apposition portion and the second apposition portion. The device may further include at least one locking member. In some embodiments, the collapsible central portion includes an unsupported region positioned between a first supported region and a second supported region.

[0005] A second aspect of the invention relates to an implantable medical device that includes (1) a first apposition portion, (2) a second apposition portion, (3) a collapsible central portion interconnecting the first and second apposition members, and (4) a tether to collapse the central portion. The device optionally includes at least one locking member. The central portion has therein at least one unsupported region that includes a cover material. In at least one exemplary embodiment, the first apposition portion includes a first elongate member and the second apposition portion includes a second elongate member. The first elongate member may have a first geometry and/or first stiffness and the second elongate member has a second geometry and/or second stiffness that is different than the first geometry and/or second stiffness. In addition, the first apposition portion and the second apposition portion may be formed of a single elongate member.

[0006] A third aspect of the invention relates to a method for creating an anastomosis that includes (1) positioning a medical device in an undeployed configuration such that the medical device spans a first body part and a second body part and (2) providing a hollow conduit therebetween. The implantable medical device includes (1) a first apposition portion, (2) a second apposition portion, (3) a collapsible central portion having at least one supported region and an unsupported region, and (4) a tether affixed to one of the first apposition portion and the second apposition portion. Optionally, the device further includes at least one locking member. The central portion interconnects the first and second apposition portions. Also, the supported region includes a frame member and the unsupported region includes a covering material. The method further includes applying a force to the tether to draw the first apposition portion and the second apposition portion towards each other and collapse the central portion to place the medical device in a deployed configuration, the deployed configuration having a shortened length relative to the undeployed configuration.

DESCRIPTION OF DRAWINGS

[0007] The accompanying drawings are included to provide a further understanding of the disclosure and are incorporated in and constitute a part of this specification, illustrate embodiments, and together with the description serve to explain the principles of the disclosure.

[0008] FIG. 1 is a cutaway perspective view of an exemplary stent device that has been implanted within a patient to act as a shunt between the patient's gallbladder and intestine in accordance with some embodiments;

[0009] FIG. 2 is a side view an exemplary anastomosis device in accordance with some embodiments;

[0010] FIG. 3 is a perspective view of the anastomosis device of FIG. 2 shown in a longitudinally contracted configuration;

[0011] FIG. 4 is a side view of the anastomosis device of FIG. 2 shown in a longitudinally contracted configuration; and

[0012] FIGS. 5–8 are a series of schematic illustrations showing the deployment process of the anastomosis device of FIG. 2.

DETAILED DESCRIPTION

[0013] Persons skilled in the art will readily appreciate that various aspects of the present disclosure can be realized by any number of methods and apparatus configured to perform the intended functions. It should also be noted that the accompanying drawing figures referred to herein are not necessarily drawn to scale, but may be exaggerated to illustrate various aspects of the present disclosure, and in that regard, the drawing figures should not be construed as limiting.

[0014] The present disclosure is directed to implantable devices for connecting tissue layers, for example, to circumvent a conduit or organ blockage, such as by creating a direct passage between tissue structures (e.g. connecting a gallbladder and a portion of a gastrointestinal tract) to create an anastomosis that facilitates material flow

therebetween. The devices described herein are endoscopically deployable or deliverable via a catheter and may include self-expanding apposition mechanisms that facilitate a secure connection between the tissue structures (such a connection may also be referred to herein as a "shunt," "passageway," "shunt passageway," or "tunnel"). Such design features simplify implantation and reduce the likelihood of complications. In some embodiments, the devices provided herein are configured to be removable after implantation. As one example, the device is implanted and remains in place until the gallbladder and/or its associated ducts are cleared of blockages, after which the device is removed. In another example, the device remains implanted until the body grows a tissue-anastomosis around the device, and then the device is removed. In other embodiments, tissue ingrowth into and/or around the device permanently implants the device, and the device is not removed. The devices described herein can provide alternative treatments for patients who are not suitable candidates for other types of treatments (e.g., gallbladder removal surgery) and/or to avoid known complications of other types of treatments (e.g., external biliary drainage).

[0015] This disclosure refers to anastomosis devices in an exemplary fashion. That is, it should be understood that the inventive concepts disclosed in this disclosure can also be applied to other types of devices. For example, this disclosure also provides implantable devices that, in some embodiments, can be used for occluding tissue structures, organs, body conduits, blood vessels, the GI tract, and the like. For example, in some embodiments the devices provided herein can be used to occlude septal defects. In some embodiments, the devices provided herein can be used to occlude a patient's vasculature or GI tract. In some such embodiments, the device does not include a tunnel or central aperture through the device. Rather, in some embodiments a covering material seals the device to inhibit, modulate, or substantially prevent material from flowing through the device.

[0016] Referring to FIG. 1, an exemplary anastomosis device 40 in accordance with some embodiments provided herein that can be implanted in a patient to create a fluidic connection between two organs, spaces, tissue structures, conduits, and the like, and combinations thereof is depicted. For example, in the depicted implementation the

anastomosis device 40 is connecting a gallbladder 10 (that defines an internal gallbladder space 12) with an intestine 20 (that defines an internal intestinal space 22). Hence, the anastomosis device 40 is acting as a fluidic shunt device between the internal gallbladder space 12 and the internal intestinal space 22. Such an implementation may provide a beneficial treatment to the patient when, for example, a flow blockage exists in the native anatomical conduits connecting the internal gallbladder space 12 and the internal intestinal space 22. For example, in some instances the patient may have one or more gallstones that cause a blockage of the patient's cystic duct 14 and/or common bile duct 16. In such a case, the anastomosis device 40 can provide a fluidic passageway such that bile from the gallbladder 10 can flow into the intestine 20. If not for the anastomosis device 40, when bile is blocked from flowing out of the gallbladder 10 cholecystitis (inflammation of the gallbladder 10) may result.

[0017] While the anastomosis devices provided herein can be used in some implementations to relieve or prevent cholecystitis as described above, it should be understood that the anastomosis devices provided herein can also be used in many other types of implementations within a patient. For example, the anastomosis devices provided herein can be used in conjunction with various body tissue structures and organs such as, but not limited to, stomachs, colons, small intestines, pancreases, blood vessels, bladders, kidneys, conduits, and the like.

[0018] In general, some embodiments of the anastomosis devices provided herein (of which anastomosis device 40 is one type of example), include a first tissue apposition portion 42a, a second tissue apposition portion 42b, and a central portion 44 therebetween. The central portion 44 defines a lumen 46 that extends longitudinally from a first end of the anastomosis device 40 to a second end of the device 40. The lumen 46 acts as a connection (e.g., a shunt, or passageway) between the internal gallbladder space 12 and the internal intestinal space 22, such that the internal gallbladder space 12 is in fluid communication with the internal intestinal space 22 via the anastomosis device 40. The lumen 46 has a radial (circular) rigidity by which the anastomosis device 40 remains patent.

[0019] It should be understood that one or more design features of the anastomosis devices provided herein can be combined with one or more other features of other anastomosis devices provided herein. In effect, hybrid designs that combine various features from two or more of the anastomosis device designs provided herein can be created, and are considered to be within the scope of this disclosure.

[0020] Referring to FIGS. 2–4, an exemplary anastomosis device 800 includes a framework of one or more elongate elements 808 that defines a first apposition portion 802, a second apposition portion 804, and a central portion 806. The anastomosis device 800 defines a longitudinal axis 801. The central portion 806 is disposed between and interconnects the first apposition portion 802 and the second apposition portion 804. In some embodiments, a covering material 812 is disposed on at least some portions of the framework.

[0021] The example anastomosis device 800 also includes a first tether 810a, a second tether 810b, and a third tether 810c. As described further below, in some embodiments the tethers 810a, 810b, and 810c are used to longitudinally contract the anastomosis device 800 *in situ*. While the depicted embodiment includes three tethers 810a, 810b, and 810c, in some embodiments less than three or more than three tethers are included. For example, in some embodiments one tether, two tethers, or more than three tethers are included.

[0022] In some embodiments, a covering material 812 is disposed on at least some portions of the anastomosis device 800. As described further below, the covering material 812 can be disposed on some portions or on all of the first apposition portion 802, the second apposition portion 804, and/or the central portion 806. In some embodiments, portions of the first apposition portion 802, the second apposition portion 804, and/or the central portion 806 can remain free of the covering material 812.

[0023] In some embodiments, the central portion 806 defines a lumen 807 that extends between the first apposition portion 802 and the second apposition portion 804. In some implementations, the lumen 807 provides a passageway through which biological materials or liquids can pass. The anastomosis device 800 is shown in an

expanded configuration (also referred to herein as a deployed configuration). The expanded or deployed configuration is the configuration that the device 800 naturally exhibits in the absence of external forces acting upon the device 800 (e.g., the forces from being radially constrained in a delivery lumen). It should be understood that when the anastomosis device 800 is implanted in a patient, the configuration of the device 800 may be somewhat different than shown because of the external forces from the patient's anatomy that are exerted on the device 800.

[0024] In some embodiments, the framework of the anastomosis device 800, as described further below, can be made of a variety of metallic shape memory materials and/or super-elastic alloys. Thus, in some embodiments the central portion 806 (and/or the apposition portions 802 and 804) can be configured to self-expand to the deployed configuration. In some embodiments, the central portion 806 is balloon expandable to the deployed configuration, or supplemental expansion forces can be applied to a self-expandable device by balloon dilation. The diameter of the central portion 806 can be made in any size as desired in order to suit the intended use and/or delivery system of the anastomosis device 800.

[0025] When the anastomosis device 800 is configured in its expanded deployed configuration as shown, the diameter of the central portion 806 increases to a deployed diameter. The diameter of the central portion 806 can be made in any dimension as desired in order to suit the intended use and/or delivery system of the anastomosis device 800. In some implementations, the deployed outer diameter of the central portion 806 is configured to at least partially anchor the device 800 via an interference fit with the tissue aperture in which the central portion 806 resides. However, in some implementations the deployed outer diameter of the central portion 806 is slightly less than the diameter of the tissue aperture in which the central portion 806 resides, and the apposition portions 802 and 804 compress the tissue to provide the migration resistance. In some embodiments, the fully expanded diameter of the central portion 806 is about 30 mm, or about 25 mm, or about 20 mm, or about 15 mm, or about 12 mm, or about 10 mm, or about 8 mm, or about 6 mm, or about 4 mm, and the like. In some embodiments, the fully expanded diameter of the central portion 806 is in a range

between about 20 mm to about 30 mm, or about 15 mm to about 25 mm, or about 10 mm to about 20 mm, or about 5 mm to about 15 mm, or about 4 mm to about 8 mm, and the like.

[0026] The length of the central portion 806 can be made in any dimension as desired in order to suit the intended use and/or delivery system of the anastomosis device 800. For instance, in one exemplary embodiment the fully longitudinally expanded central portion 806 is about 50 mm in length. In some embodiments, the length of the central portion 806 can be in a range from about 40 mm to about 70 mm, or about 30 mm to about 60 mm, or about 20 mm to about 50 mm, or about 10 mm to about 40 mm, or about 20 mm to about 40 mm.

[0027] In some embodiments, the anastomosis device 800 has a framework that comprises one or more elongate elements 808. In some embodiments, the one or more elongate elements 808 are wound into the framework configuration. In some embodiments, a single elongate element 808 is wound to form the framework of the anastomosis device 800. In some embodiments, two or more elongate elements 808 are cooperatively wound to form the framework of the anastomosis device 800.

[0028] In some embodiments, the framework of the first apposition portion 802, the second apposition portion 804, and the central portion 806 are formed of one or more elongate elements 808 made of materials such as, but not limited to, spring wire (e.g., L605 steel or stainless steels), shape memory alloy wire (e.g., nitinol or nitinol alloys), super-elastic alloy wire (e.g., nitinol or nitinol alloys), other suitable types of elongate elements or wires, or combinations thereof. In some embodiments, the first apposition portion 802, the second apposition portion 804, and the central portion 806 are formed from a precursor material that is cut to create the framework of elongate elements 808. In some such embodiments, the precursor material is a single piece of precursor material. In some embodiments, one or more elongate elements 808 are wound into a configuration to form the framework. In some embodiments, different types of elongate elements 808 are used at different locations of the first apposition portion 802, the second apposition portion 804, and/or the central portion 806. In some embodiments,

the elongate elements 808 of the first apposition portion 802, the second apposition portion 804, and/or the central portion 806 (or portions thereof) may be constructed of polymeric materials.

[0029] Suitable materials for the elongate elements 808 of the anastomosis device 800 and/or other devices provided herein include a variety of metallic materials including alloys exhibiting, shape memory, elastic and super-elastic characteristics. Shape memory refers to the ability of a material to revert to an originally memorized shape after plastic deformation by heating above a critical temperature. Elasticity is the ability of a material to deform under load and return (or substantially return) to its original shape when the load is released. Most metals will deform elastically up to a small amount of strain. Super-elasticity refers to the ability of a material to deform under strain to much larger degree than typical elastic alloys, without having this deformation become permanent. For example, the super-elastic materials included in the frames of some anastomosis device embodiments provided herein are able to withstand a significant amount of bending and flexing and then return to or substantially to the frame's original form without deformation. In some embodiments, suitable elastic materials include various stainless steels which have been physically, chemically, and otherwise treated to produce a high springiness, metal alloys such as cobalt chrome alloys (e.g., ELGILOY™, MP35N, L605), platinum/tungsten alloys. Embodiments of shape memory and super-elastic alloys include the NiTi alloys, ternary shape memory alloys such as NiTiPt, NiTiCo, NiTiCr, or other shape memory alloys such as copper-based shape memory alloys. Additional materials could combine both shape memory and elastic alloys such as drawn filled tube where the outer layer is constructed of nitinol and the inner core is a radiopaque material such as platinum or tantalum. In this construct, the outer layer provides the super-elastic properties and the inner core remains elastic due to lower bending stresses.

[0030] In some embodiments, the elongate elements 808 used to construct the anastomosis device 800 and/or other devices provided herein can be treated in various ways to increase the radiopacity of the devices for enhanced radiographic visualization. In some embodiments, the devices are least partially a drawn-filled type of NiTi

containing a different material at the core, such as a material with enhanced radiopacity. In some embodiments, the devices include a radiopaque cladding or plating on at least portions of the first apposition portion, the second apposition portion, and the central portion. In some embodiments, one or more radiopaque markers are attached to the devices. In some embodiments, the elongate elements and/or other portions of the devices provided herein are also visible via ultrasound, and may include portions with enhanced echogenicity.

[0031] In some embodiments, the materials and configuration of the anastomosis device 800 (and the other anastomosis device embodiments provided herein) allow the devices to be elastically crushed, folded, and/or collapsed into a low-profile delivery configuration for containment within a lumen for transcatheter or endoscopic/thoroscopic delivery, and to self-expand to an operative size and configuration once positioned at a desired target site within a body and deployed from the lumen. For example, in the low-profile delivery configuration the anastomosis device 800 can be disposed within a delivery sheath that has about a 15 Fr. (5 mm) outer diameter. However, in some embodiments, sheaths that are smaller or larger than 15 Fr. can be used. For example, sheaths that have outer diameters of 6 Fr., 7 Fr., 8 Fr., 9 Fr., 10 Fr., 11 Fr., 12 Fr., 13 Fr., 14 Fr., 16 Fr., 17 Fr., 18 Fr., 19 Fr., 20 Fr., and larger than 20 Fr., can be used in some embodiments. While the anastomosis device 800 is configured in a collapsed delivery configuration, in some embodiments the framework of one or more elongate elements 808 is radially compressed such that the elongate elements 808 are forced to extend substantially parallel to axis of the central portion 806, and the diameter of the central portion 806 is crushed to become smaller.

[0032] The anastomosis device 800 also includes the covering material 812 (which may also be referred to herein as a "covering"). In some embodiments, the covering material 812 is disposed on at least some portions (or on all) of the first apposition portion 802, the second apposition portion 804, and the central portion 806. In some embodiments, some portions of the first apposition portion 802, the second apposition portion 804, and/or the central portion 806 are not covered by the covering material 812.

[0033] In some embodiments, the covering material 812 is generally fluid impermeable. That is, in some embodiments the covering material 812 is made of a material that inhibits or reduces passage of blood, bile and/or other bodily fluids and materials through the covering material 812 itself. In some embodiments, the covering material 812 has a material composition and configuration that inhibits or prevents tissue ingrowth and/or endothelialization or epithelialization into the covering material 812. Some such embodiments that are configured to inhibit or prevent tissue ingrowth and/or endothelialization can be more readily removed from the patient at a future date if so desired. In some embodiments, the covering material 812, or portions thereof, has a microporous structure that provides a tissue ingrowth scaffold for durable sealing and/or supplemental anchoring strength of the anastomosis device 800.

[0034] In some embodiments, the covering material 812 comprises a fluoropolymer, such as an expanded polytetrafluoroethylene (ePTFE) polymer, or polyvinylidene fluoride (PVDF). In some embodiments, the covering material 812 comprises a polyester, a silicone, a urethane, biocompatible polymer(s), polyethylene terephthalate (e.g., Dacron®), bioabsorbable materials, copolymers, or combinations thereof. In some embodiments, the covering material 812 comprises a bioabsorbable web. In other embodiments, the bioabsorbable material may also provide an anti-migration feature by promoting attachment between the device 800 and tissue until the bioabsorbable material is absorbed.

[0035] In some embodiments, the covering material 812 (or portions thereof) is modified by one or more chemical or physical processes that enhance one or more properties of the material 812. For example, in some embodiments, a hydrophilic coating may be applied to the covering material 812 to improve the wettability and echo translucency of the material 812. In some embodiments, the covering material 812, or portions thereof, may be modified with chemical moieties that facilitate one or more of endothelial cell attachment, endothelial cell migration, endothelial cell proliferation, and resistance to or promotion of thrombosis. In some embodiments, the covering material 812, or portions thereof, may be modified to resist biofouling. In some embodiments, the covering material 812, or portions thereof, may be modified with one or more

covalently attached drug substances (e.g., heparin, antibiotics, and the like) or impregnated with the one or more drug substances. The drug substances can be released *in situ* to promote healing, reduce tissue inflammation, reduce or inhibit infections, and to promote various other therapeutic treatments and outcomes. In some embodiments, the drug substance may be, but is not limited to a corticosteroid, a human growth factor, an anti-mitotic agent, an antithrombotic agent, a stem cell material, or dexamethasone sodium phosphate. In some embodiments, a pharmacological agent is delivered separately from the covering material 812 to the target site to promote tissue healing or tissue growth.

[0036] Coatings and treatments may be applied to the covering material 812 before or after the covering material 812 is joined or disposed on or around the framework of the anastomosis device 800. Additionally, one or both sides of the covering material 812, or portions thereof, may be coated. In some embodiments, certain coatings and/or treatments are applied to the covering material(s) 812 located on some portions of the anastomosis device 800, and other coatings and/or treatments are applied to the material(s) 812 located on other portions of the anastomosis device 800. In some embodiments, a combination of multiple coatings and/or treatments are applied to the covering material 812, or portions thereof. In some embodiments, certain portions of the covering material 812 are left uncoated and/or untreated. In some embodiments, the device 800 is fully or partially coated to facilitate or frustrate a biological reaction, such as, but not limited to, endothelial cell attachment, endothelial cell migration, endothelial cell proliferation, and resistance to or promotion of thrombosis.

[0037] In some embodiments, a first portion of the covering material 812 is formed of a first material and a second portion of the covering material 812 is formed of a second material that is different than the first material. In some embodiments, the covering material 812 is comprised of multiple layers of materials, which may be the same or different materials. In some embodiments, portions of the covering material 812 have one or more radiopaque markers attached thereto to enhance *in vivo* radiographic visualization of the anastomosis device 800, or one or more echogenic areas to enhance ultrasonic visibility.

[0038] In some embodiments, one or more portions of the covering material 812 are attached to the framework of the device 800, such as the central portion 806 and/or the apposition portions 802 and 804. The attachment can be accomplished by a variety of techniques such as, but not limited to, stitching the covering material 812 to the framework of the device 800, adhering the covering material 812 to the framework of the device 800, laminating multiple layers of the covering material 812 to encompass portions of the elongate members of the device 800, using clips or barbs, laminating multiple layers of the covering material together through openings in the framework of the device 800. In some embodiments, the covering material 812 is attached to the framework of the device 800 at a series of discrete locations, thereby facilitating the flexibility of the framework. In some embodiments, the covering material 812 is loosely attached to the framework of the device 800. It is to be appreciated that the covering material 812 may be attached to the framework using other techniques or combinations of techniques described herein.

[0039] In some embodiments, the framework of the device 800 (or portions thereof) is coated with a bonding agent (e.g., fluorinated ethylene propylene (FEP) or other suitable adhesive) to facilitate attachment of the covering material 812 to the framework. Such adhesives may be applied to the framework using contact coating, powder coating, dip coating, spray coating, or any other appropriate means.

[0040] In some embodiments, the covering material 812 can adapt to changes in the length and/or diameter of the central portion 806 in a variety of manners. In a first example, the covering material 812 can be elastic such that the covering material 812 can stretch to accommodate changes in the length and/or diameter of the device 800. In a second example, the covering material can include slackened material in the low-profile delivery configuration that becomes less slackened or totally unslackened when the device 800 is in the expanded configuration. In a third example, the covering material 812 can include folded portions (e.g., pleats) that are folded in the low-profile configuration and less folded or totally unfolded when the device 800 is in the expanded configuration. In some embodiments, combinations of such techniques, and/or other

techniques can be used whereby the covering material 812 can adapt to changes in the length and/or diameter of the central portion 806.

[0041] The one or more elongate element(s) 808 of the central portion 806 can be configured in various ways to define a generally cylindrical framework. In the embodiment depicted in FIG. 2, the elongate element(s) 808 of the central portion 806 are wound circumferentially around the central portion 806. In addition to the circumferential winding, the elongate element(s) 808 can exhibit other winding paths, such as the wavy or serpentine path shown (e.g., approximately sinusoidal) and other paths. In the depicted embodiment, the winding path of the elongate element(s) 808 in the central portion 806 has about eight apices per circumference. In some embodiments, the elongate element(s) 808 of the central portion 806 can be made to have more or less than eight apices per circumference. For example, in some embodiments the elongate element(s) 808 of the central portion 806 can be made to have three, four, five, six, seven, nine, ten, eleven, twelve, thirteen, fourteen, fifteen, sixteen, or more than sixteen apices per circumference.

[0042] It should be understood that, while the anastomosis device 800 is in the expanded configuration, the anastomosis device 800 may be selectively adjusted to a desired longitudinal length by manipulation of the tethers 810a, 810b, and 810c. For example, FIG. 2 shows the anastomosis device 800 configured to have its maximum longitudinal length. In contrast, FIGS. 3 and 4 show the anastomosis device 800 configured to have a shorter longitudinal length. The shorter longitudinal length of the anastomosis device 800 is attained by pulling tethers 810a, 810b, and 810c proximally, to thereby longitudinally compress (contract) the central portion 806. Hence, the central portion 806 of the anastomosis device 800 can be characterized as being selectively longitudinally contractible. In some embodiments, the tethers 810a, 810b, and 810c will lock in their positions such that the longitudinally contracted arrangement of the anastomosis device 800 will be retained.

[0043] In some embodiments, the anastomosis device 800 includes a single elongate element 808. That is, in some embodiments a single continuous elongate element 808 forms the framework of each of the first apposition portion 802, the second apposition portion 804, and the central portion 806.

[0044] In some embodiments, the anastomosis device 800 includes two elongate elements 808. That is, in some embodiments two elongate elements 808 are used to form the framework of the first apposition portion 802, the second apposition portion 804, and the central portion 806. For example, in some embodiments a first elongate element 808 may form the framework of just the first apposition portion 802, and a second elongate element 808 may form the framework of both of the second apposition portion 804 and the central portion 806. In another example, a first elongate element 808 may form the framework of both of the first apposition portion 802 and the central portion 806, and a second elongate element 808 may form the framework of just the second apposition portion 804.

[0045] In some embodiments, the anastomosis device 800 includes three elongate elements 808. That is, in some embodiments a first continuous elongate element 808 forms the framework of the first apposition portion 802, a second elongate element 808 forms the framework of the second apposition portion 804, and a third elongate element 808 forms the framework of the central portion 806. Such a configuration may provide some advantages. For example, having a separate elongate element 808 in the central portion 806 may allow for a smaller low-profile delivery configuration. In addition, a separate elongate element 808 in the central portion 806 may allow for more conformability to tissue topography and allow the central axis 801 to bend to accommodate organ locations and/or peristalsis, generally independent of the first and second apposition portions 802 and 804.

[0046] In some embodiments, the anastomosis device 800 includes more than three elongate elements 808. In some embodiments, one or both of the first apposition portion 802 and/or the second apposition portion 804 can be comprised of more than one elongate elements 808.

[0047] In some embodiments that include two or more elongate elements 808, the elongate elements 808 may have differing properties, such as, but not limited to, diameters, stiffnesses, material compositions, shape-memory properties, cross-sectional shapes, geometries, elasticities, and the like.

[0048] The anastomosis device 800 includes the first apposition portion 802 and the second apposition portion 804. In some embodiments, the configurations (geometries) of the apposition portions 802 and 804 are substantially the same. In some embodiments, the configurations of the apposition portions 802 and 804 are different from each other. For example, in some embodiments the first apposition portion 802 may have multiple apposition members 803 (refer to FIG. 3), while the second apposition portion 804 may have more, fewer, or no apposition members 803. In another example, in some embodiments the first apposition portion 802 may have multiple apposition members 803 shaped generally as shown, while the second apposition portion 804 may have multiple apposition members that are shaped differently. All such combinations and permutations are envisioned, and within the scope of this disclosure.

[0049] In some embodiments, such as the depicted embodiment, the elongate element 808 of the central portion 806 is configured in a sinusoidal pattern that is wrapped helically around the longitudinal axis 801 along the central portion 806. In some embodiments, a majority of the central portion 806 is unsupported by the elongate element 808 of the central portion 806. In some embodiments, one or more elongate elements 808 may be configured in any other suitable arrangement in the central portion 806.

[0050] In some embodiments, the central portion 806 includes one or more supported regions and one or more unsupported regions. The one or more supported regions are the regions of the central portion 806 where the elongate element 808 is disposed. The one or more unsupported regions are the regions of the central portion 806 where no elongate element 808 is disposed (hence the covering material 812 is unsupported by the elongate element 808 in the unsupported regions).

[0051] The anastomosis device 800 includes the tethers 810a, 810b, and 810c. In some embodiments the tethers 810a, 810b, and 810c are used to longitudinally contract the anastomosis device 800 *in situ*. That is, by pulling on tethers 810a, 810b, and 810c, a clinician can longitudinally shorten the central portion 806 of the anastomosis device 800. In some embodiments, the tethers 810a, 810b, and 810c are disposed in a range from about 100° to about 140° apart from each other, or in a range from about 110° to about 130° apart from each other, or at about 120° apart from each other around the periphery of the anastomosis device 800. In some embodiments, other relative arrangements between the tethers 810a, 810b, and 810c are used. While in the depicted embodiment, the anastomosis device 800 includes three tethers 810a, 810b, and 810c, in some embodiments one, two, four, five, six, seven, eight, nine, ten, or more than ten tethers are included.

[0052] In some embodiments, the tethers 810a, 810b, and 810c are made of materials such as, but not limited to, PTFE (polytetrafluoroethylene), nylon, and the like, and combinations thereof. In some embodiments, the tethers 810a, 810b, and 810c are monofilaments. In some embodiments, the tethers 810a, 810b, and 810c are multifilament constructs such as braided or twisted constructs. In some embodiments, it is advantageous for the tethers 810a, 810b, and 810c to have low elasticity to provide a clinician with precision control of the application of contraction forces to the central portion 806.

[0053] In some embodiments, the paths of the tethers 810a, 810b, and 810c are generally as follows. The first ends of the tethers 810a, 810b, and 810c are located proximally and exterior to the patient such that the clinician can apply tension to the tethers 810a, 810b, and 810c. From the proximal ends, the tethers 810a, 810b, and 810c extend towards the anastomosis device 800 (e.g., through one or more lumens of a catheter). As shown, the tethers 810a, 810b, and 810c pass through a proximal end (e.g., near apposition portion 804) of the anastomosis device 800 and extend to a distal end (e.g., near apposition portion 802) of the anastomosis device 800. At the distal end of the anastomosis device 800, the tethers 810a, 810b, and 810c are routed through or around a structure of the anastomosis device (e.g., the elongate element 808 or

covering material 812) and then back towards the proximal end of the anastomosis device 800. The second ends of the tethers 810a, 810b, and 810c are tied or otherwise affixed to a structure of the anastomosis device 800 at the proximal end of the anastomosis device 800. As a result of being routed in this fashion, when a clinician pulls or applies tension to one or more of the tethers 810a, 810b, and 810c, the central portion 106 of the anastomosis device 800 will be longitudinally compressed.

[0054] In some embodiments, locking members are included such that the tethers 810a, 810b, and 810c remain detained (locked) in a tensioned state after the clinician has induced a desired amount of shortening to the central portion 806 by pulling on the tethers 810a, 810b, and 810c.

[0055] The anastomosis device 800 can advantageously be used to adapt to a range of tissue thicknesses. Accordingly, the size selection of the anastomosis device 800 for a particular target location is simplified. In the example deployment process depicted in FIGS. 5–8, the anastomosis device 800 is being used to create an anastomosis between two tissue walls 50 and 60.

[0056] Referring to FIG. 5, a deployment catheter 900 that has been navigated to an opening between the two tissue walls 50 and 60 is shown. The deployment catheter 900 contains the anastomosis device 800 in a radially compressed low-profile delivery configuration. In some implementations, the deployment catheter 900 has been navigated to the opening via an endoscope working channel.

[0057] Referring to FIG. 6, the anastomosis device 800 has been deployed from the deployment catheter 900. The anastomosis device 800 has been deployed such that the first apposition portion 802 and the second apposition portion 804 are on opposite sides of the double tissue walls 50 and 60. In some embodiments, the deployment comprises removing an outer containment member from the anastomosis device 800 (such as a polymeric sleeve that can be “unzipped”). In some embodiments, the deployment comprises pushing the anastomosis device 800 out of a lumen. In some embodiments, the deployment comprises pulling back a delivery sheath so that the anastomosis device emerges from a lumen of the delivery sheath.

[0058] Initially after deployment from the deployment catheter 900, the anastomosis device 800 is radially expanded and longitudinally expanded. Radially, the anastomosis device 800 conforms to the opening or near to the opening of the tissues 50 and 60. Longitudinally, the anastomosis device 800 is in its full length arrangement.

[0059] Referring to FIG. 7, a clinician user can apply tension to the tethers 810a, 810b, and 810c to longitudinally shorten (contract) the anastomosis device 800. In doing so, the first apposition portion 802 and the second apposition portion 804 can come into contact with the tissue walls 60 and 50 respectively. In some implementations, the contraction of the anastomosis device 800 may also force the tissue walls 50 and 60 closer together, or into contact with each other.

[0060] Referring to FIG. 8, the deployment catheter 900 can be withdrawn. In some implementations, the tethers 810a, 810b, and 810c are left attached to the anastomosis device 800 as shown. In some implementations, the tethers 810a, 810b, and 810c are left attached to the anastomosis device 800 but the tethers 810a, 810b, and 810c are trimmed in length. The tethers 810a, 810b, and 810c may be used later to assist with removal of the anastomosis device 800 in some cases.

[0061] The anastomosis devices provided herein are deployable to a target site within a patient using one or more catheters, delivery sheaths, and other suitable devices and techniques. In some implementations, the anastomosis devices provided herein are deployable using an endoscopic or laparoscopic approach.

[0062] In some embodiments the devices provided herein can be used for sealing or anchoring a heart valve implant. A heart valve implant enables one-way flow of blood from a heart chamber and usually has a first inflow end and a second outflow end. The contractions of the heart cause flow of blood through the valve from the inflow end to the outflow end. Between the inflow and outflow ends, a valve assembly within the heart valve implant provides for one way flow, opening to allow flow from the inflow to the outflow end when the pressure of the blood is higher on the inflow end, and closing to prevent flow when the pressure on the outflow end is higher than the inflow end. In some embodiments, the device includes a tunnel or central aperture through the device

with apposition portions to anchor a valve assembly and seal against backward flow. A valve assembly can be attached in the tunnel or central aperture. The apposition portions of the device can be configured to be highly conformable to the topography of the heart chambers or blood vessels, and compliant with the beating movements of the heart. In some embodiments, a covering material is configured to allow flow through a valve assembly in the tunnel or aperture while preventing flow around the apposition portions.

[0063] It should be understood that one or more design features of the anastomosis devices provided herein can be combined with other features of other anastomosis devices provided herein. In effect, hybrid designs that combine various features from two or more of the anastomosis device designs provided herein can be created, and are within the scope of this disclosure.

[0064] The invention of this application has been described above both generically and with regard to specific embodiments. It will be apparent to those skilled in the art that various modifications and variations can be made in the embodiments without departing from the scope of the disclosure. Thus, it is intended that the embodiments cover the modifications and variations of this invention provided they come within the scope of the appended claims and their equivalents.

WHAT IS CLAIMED IS:

1. An implantable medical device comprising:

a first apposition portion having a plurality of first apposition members;

a second apposition portion having a plurality of second apposition members;

and

a central portion that is selectively longitudinally contractible, the central portion having at least one supported region and at least one an unsupported region, said central portion interconnecting said first and second apposition portions,

wherein said supported region comprises a frame member and said unsupported region comprises a covering material.

2. The implantable medical device of claim 1, wherein said first apposition portion and said supported region comprise a first elongate member and said second apposition portion comprises a second elongate member.

3. The implantable medical device of claim 2, wherein said unsupported region consists of said cover material.

4. The implantable medical device of claim 2, wherein said first elongate member has a first stiffness and said second elongate member has a second stiffness that is different than said first stiffness.

5. The implantable medical device of claim 2, wherein said first elongate member has a first geometry and said second elongate member has a second geometry that is different than said first geometry.

6. The implantable medical device of claim 1, wherein said first apposition portion, said supported region, and said second apposition member comprises a single elongate member.

7. The implantable medical device of claim 1, further comprising a tether affixed to one of said first apposition portion and said second apposition portion.

8. The implantable medical device of claim 7, further comprising a locking member.

9. The implantable medical device of claim 1, wherein said collapsible central portion comprises an unsupported region positioned between a first supported region and a second supported region.

10. The implantable medical device of claim 1, wherein said cover material is selected from the group consisting of a fluoropolymer film, bioabsorbable films, polyurethane, silicone, polypropylene, polyester and combinations thereof.

11. An implantable medical device comprising:

- a first apposition portion;

- a second apposition portion;

- a collapsible central portion interconnecting said first and second apposition members, said central portion having therein at least one unsupported region comprising a cover material, and

- a tether to collapse said central portion.

12. The implantable medical device of claim 11, wherein said first apposition portion comprises a first elongate member and said second apposition portion comprises a second elongate member.

13. The implantable medical device of claim 12, wherein said first elongate member has a first geometry and said second elongate member has a second geometry that is different than said first geometry.

14. The implantable medical device of claim 12, wherein said first elongate member has a first stiffness and said second elongate member has a second stiffness that is different than said second stiffness.

15. The implantable medical device of claim 11, wherein said first apposition portion and said second apposition portion comprise a single elongate member.

16. The implantable medical device of claim 11, further comprising a locking member.

17. The implantable medical device of claim 11, wherein said cover material is selected from the group consisting of a fluoropolymer film, bioabsorbable films, polyurethane, silicone, polypropylene, polyester and combinations thereof.

18. A method for creating an anastomosis, said method comprising:

positioning a medical device in an undeployed configuration such that said medical device spans a first body part and a second body part and provides a hollow conduit therebetween, said implantable medical device comprising:

a first apposition portion;

a second apposition portion;

a collapsible central portion having at least one supported region and an unsupported region, said central portion interconnecting said first and second apposition portion, wherein said supported region comprises a frame member and said unsupported region comprises a covering material; and

a tether affixed to one of said first apposition portion and said second apposition portion; and

applying a force to said tether to draw said first apposition portion and said second apposition portion towards each other and collapse said central portion to

place said medical device in a deployed configuration, said deployed configuration having a shortened length relative to said undeployed configuration.

19. The method of claim 18, wherein said medical device further comprises a locking member.

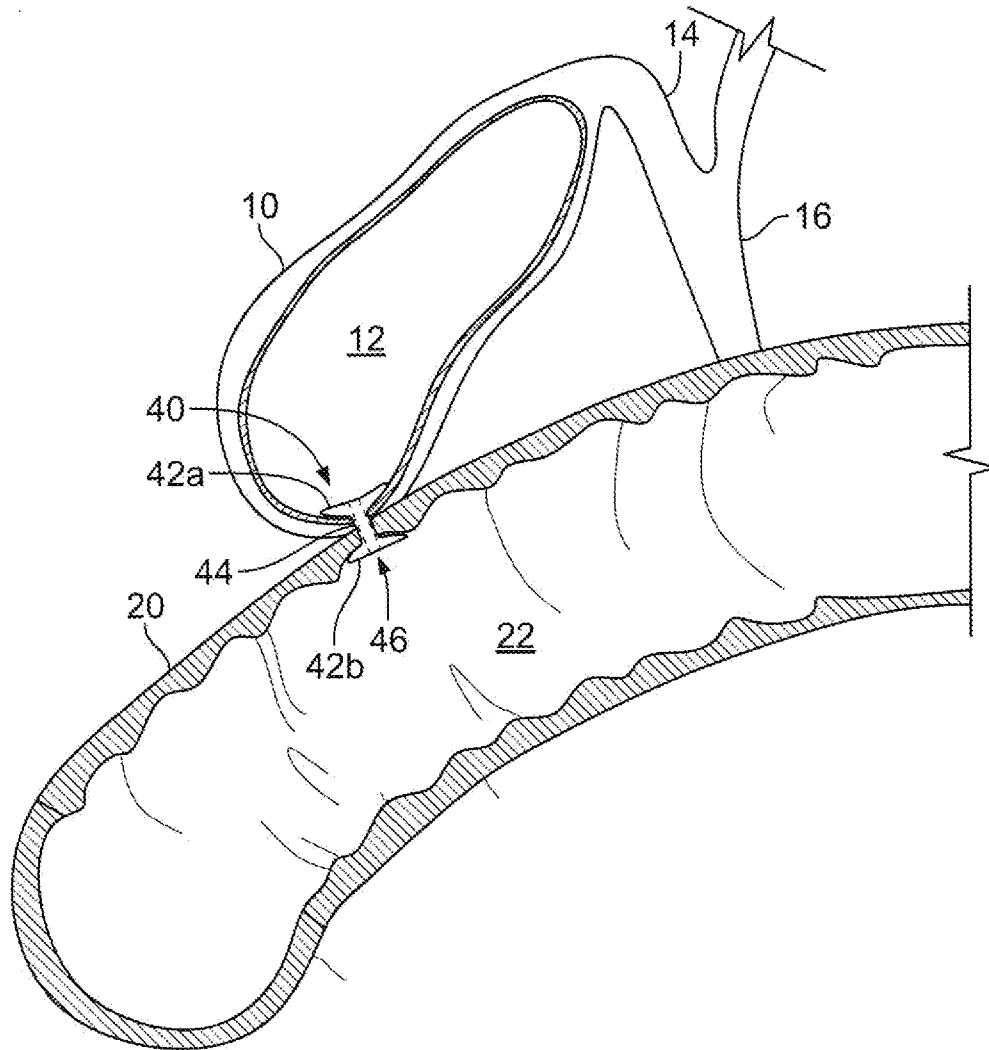

FIG. 1

2/5

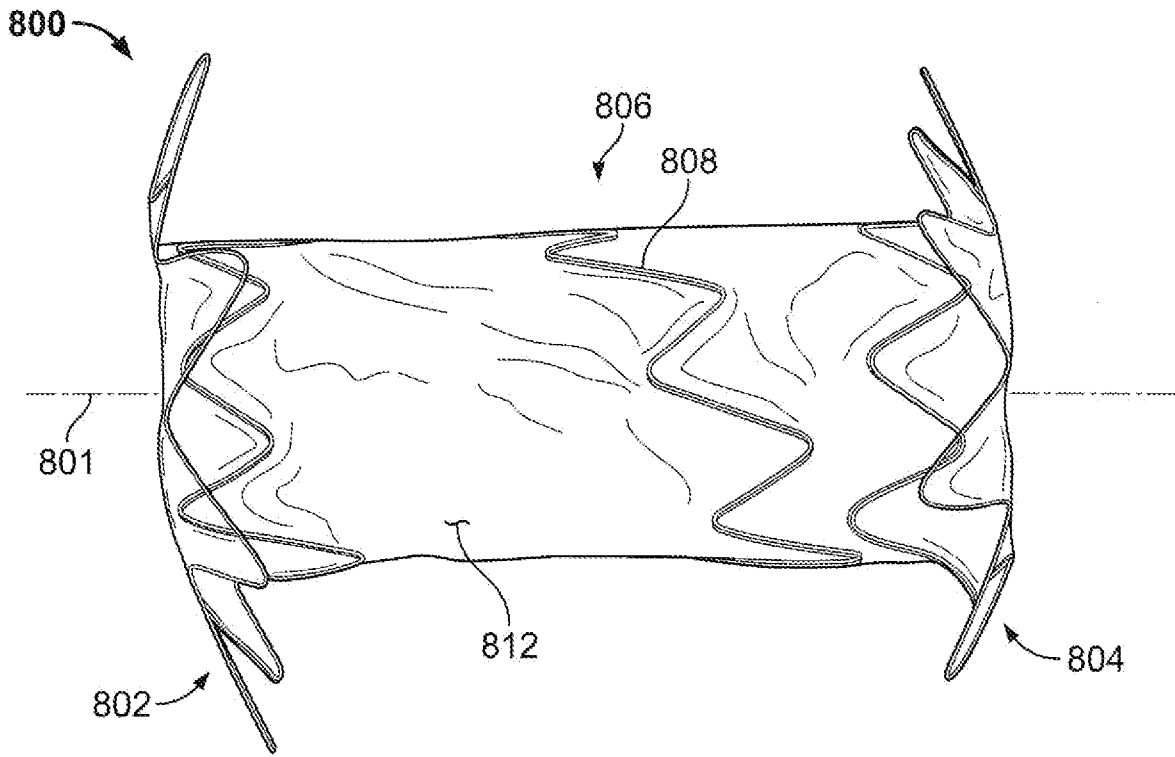

FIG. 2

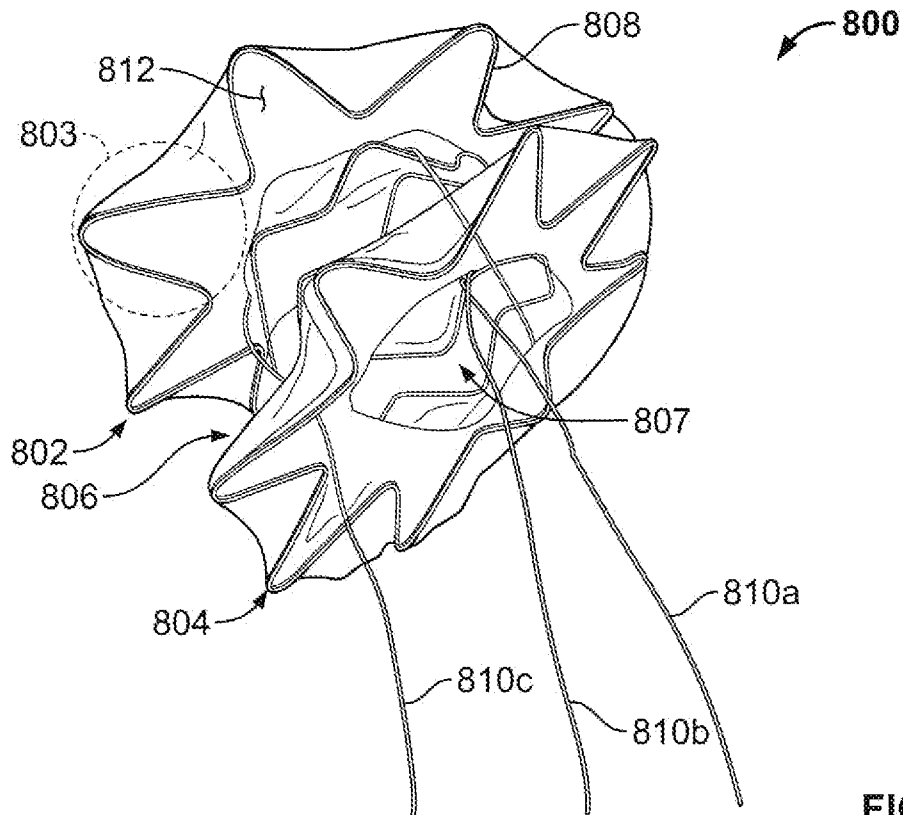

FIG. 3

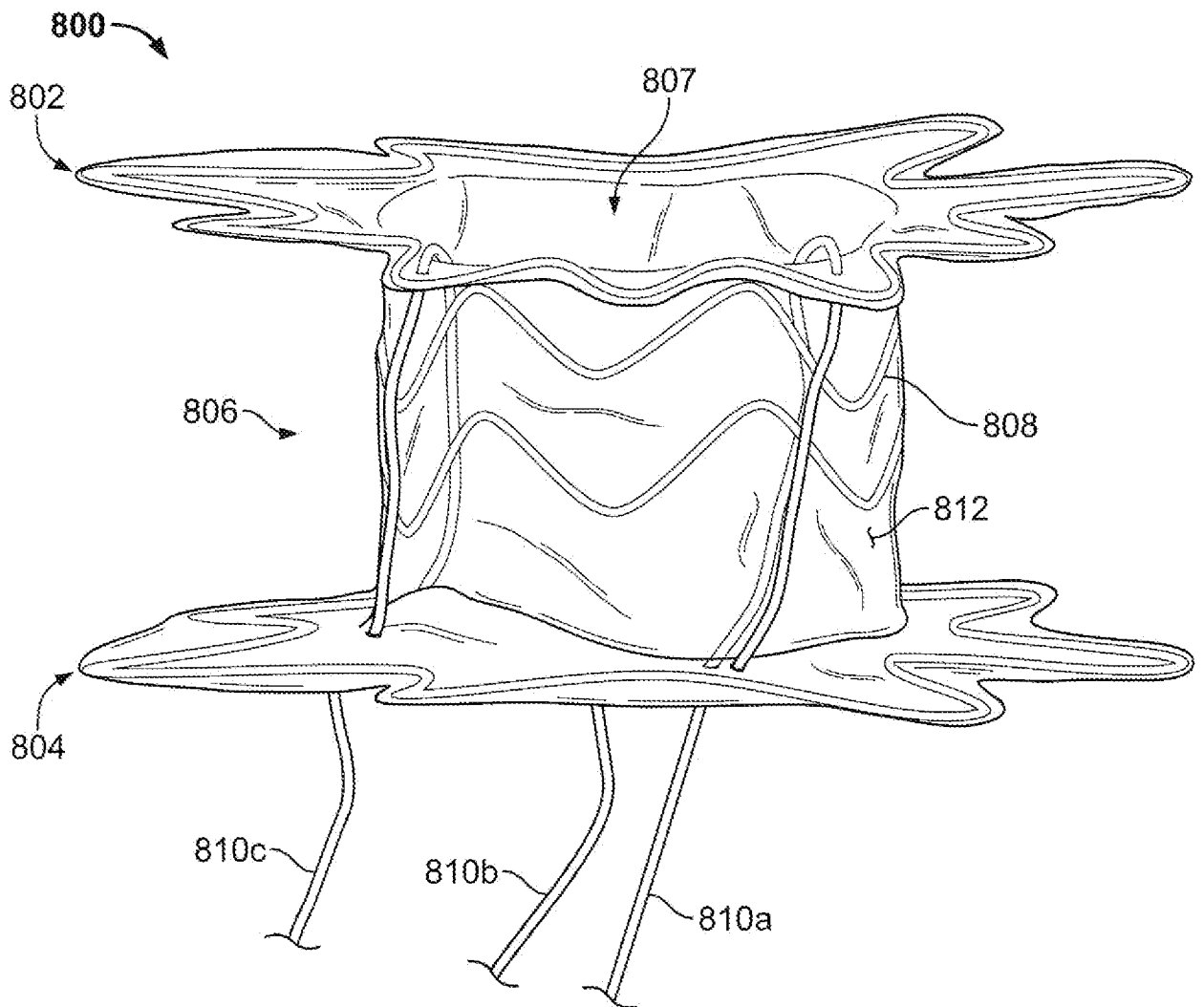

FIG. 4

4/5

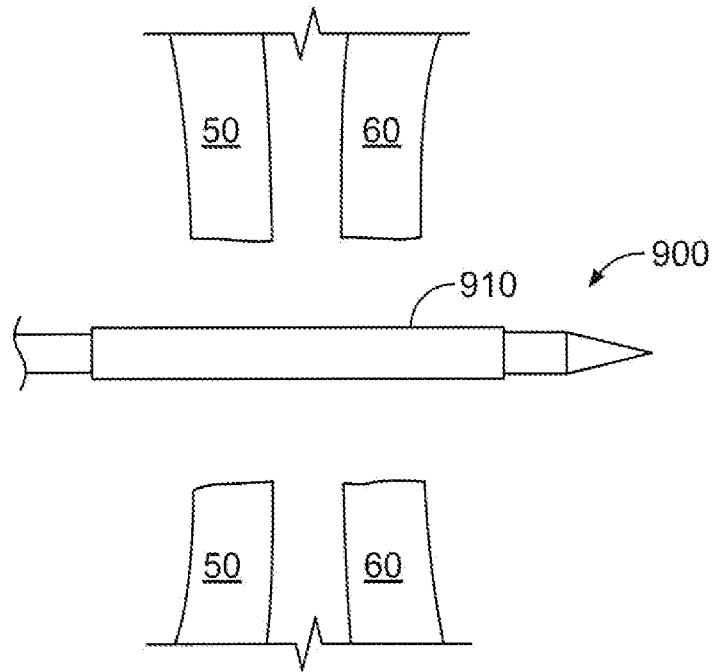

FIG. 5

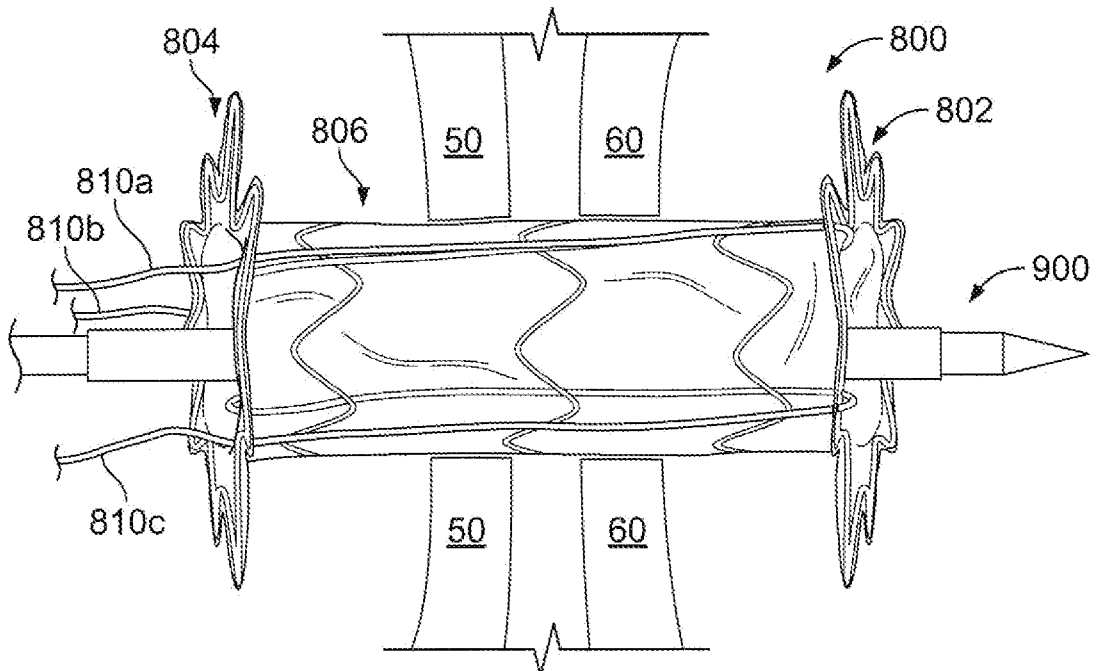

FIG. 6

5/5

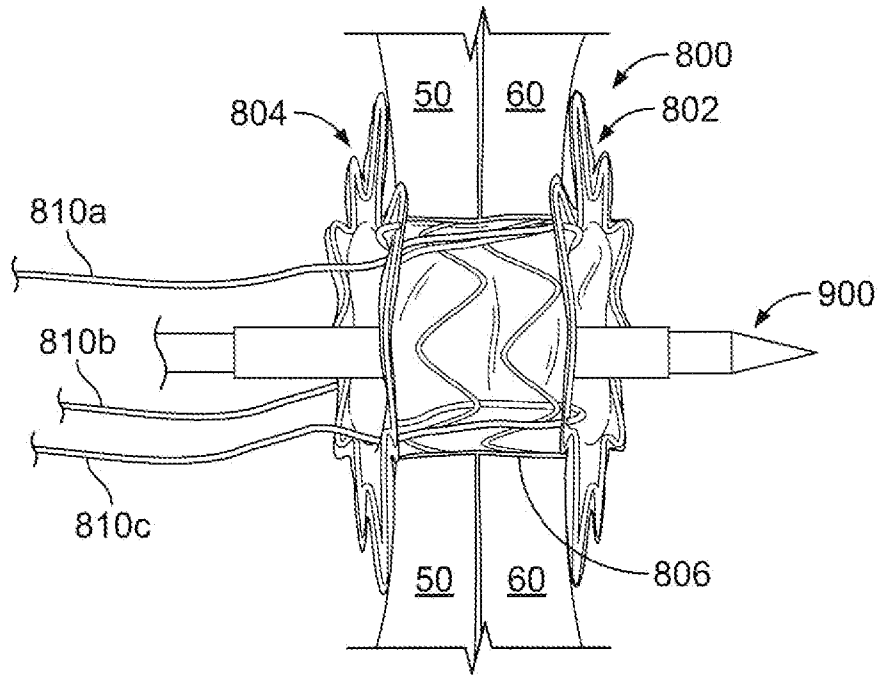

FIG. 7

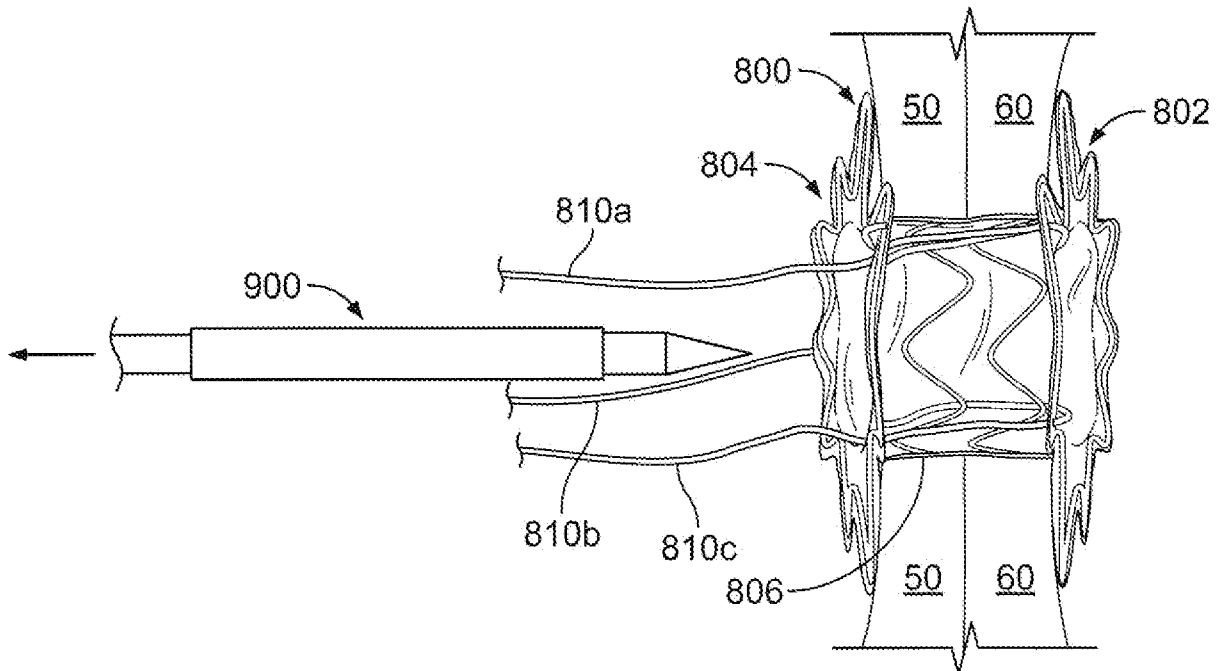

FIG. 8