

(12) **UK Patent Application** (19) **GB** (11) **2 321 866** (13) **A**

(43) Date of A Publication 12.08.1998

(21) Application No **9702474.9**

(22) Date of Filing **07.02.1997**

(71) Applicant(s)
Weatherford/Lamb, Inc.
(Incorporated in USA - Delaware)
Prentice Hall Corporation System, Inc.,
32 Lockerman Square, Suite L-100, Dover,
Delaware 19901, United States of America

(72) Inventor(s)
Bernd-Georg Pietras

(74) Agent and/or Address for Service
Lucas & Co
135 Westhall Road, WARLINGHAM, Surrey, CR6 9HJ,
United Kingdom

(51) INT CL⁶
E21B 19/16

(52) UK CL (Edition P)
B3N N2A6 N2E2
U1S S1748

(56) Documents Cited
GB 2049517 A

(58) Field of Search
UK CL (Edition O) **B3N**
INT CL⁶ **E21B**
Online: **WPI**

(54) Abstract Title
Jaw unit for use in a tong

(57) A jaw unit 102 for use in a tong comprises jaw holders 105 and jaws 106 movable with respect to the jaw holders 105. The jaws 106 are slidably mounted on an arcuate track 108 provided on each jaw holder 105. A rotary fitted with such a jaw unit may be formed as a one-piece casting. The jaw or jaw holder may comprise a plurality of laminations.

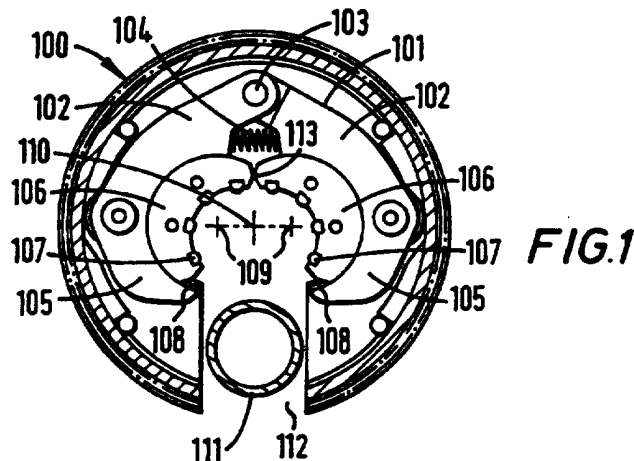

GB 2 321 866 A

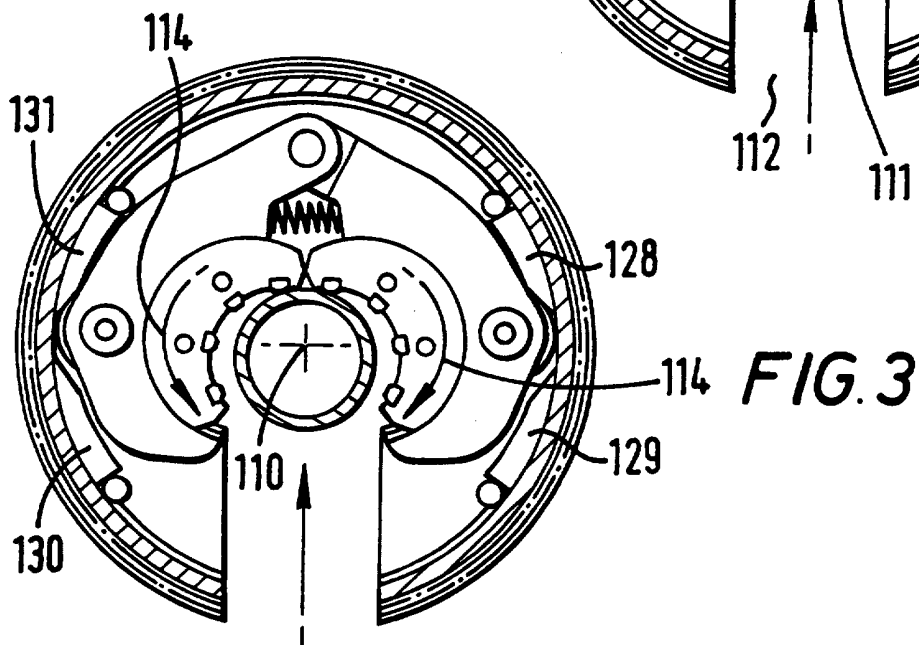
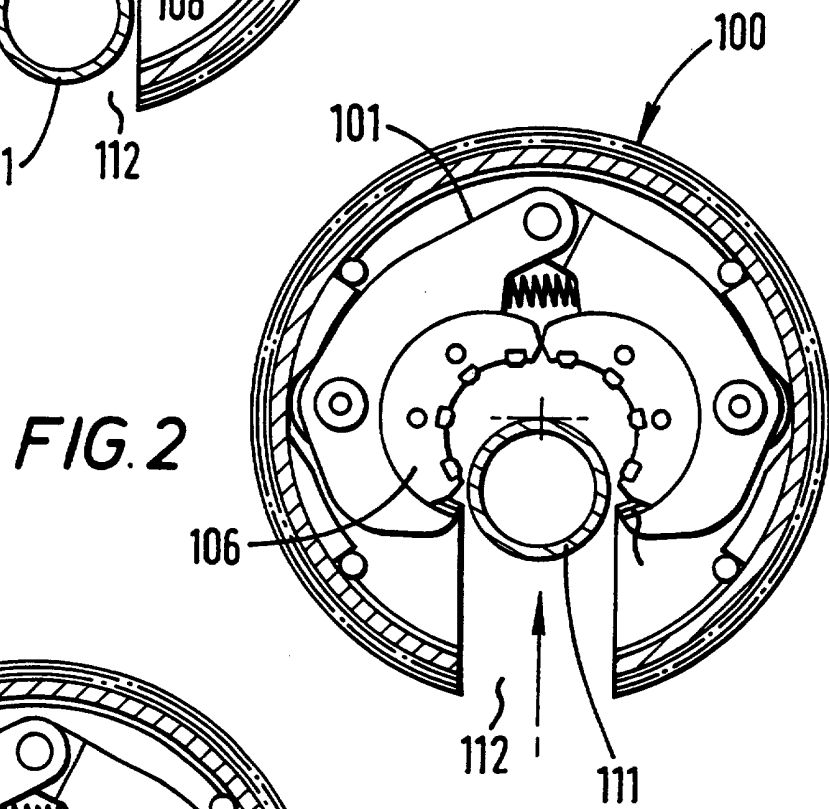
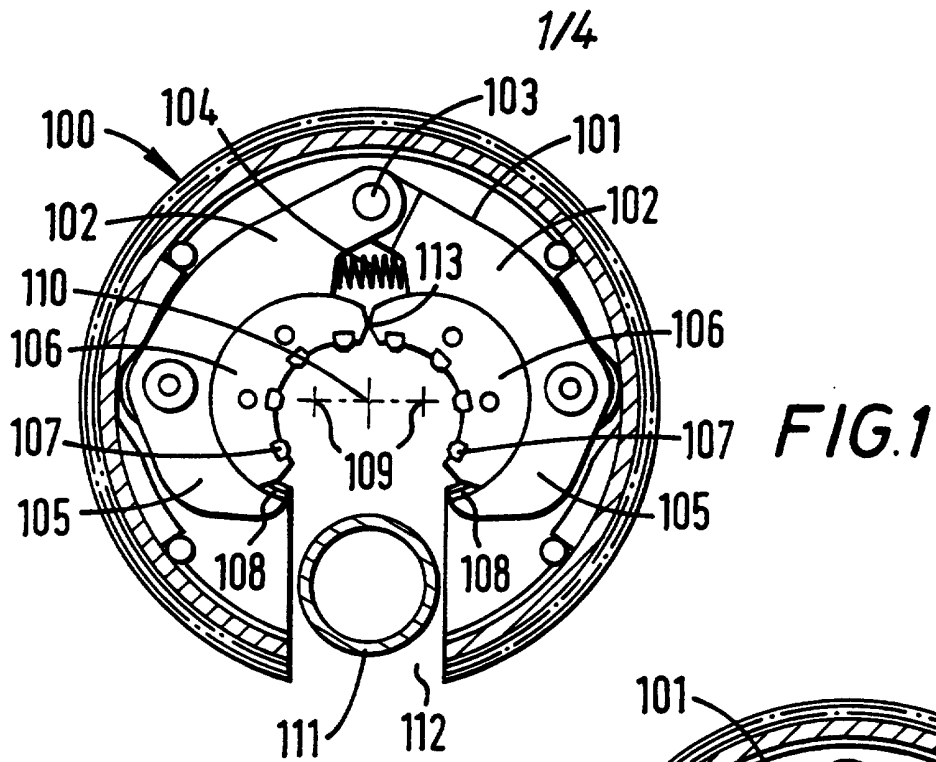

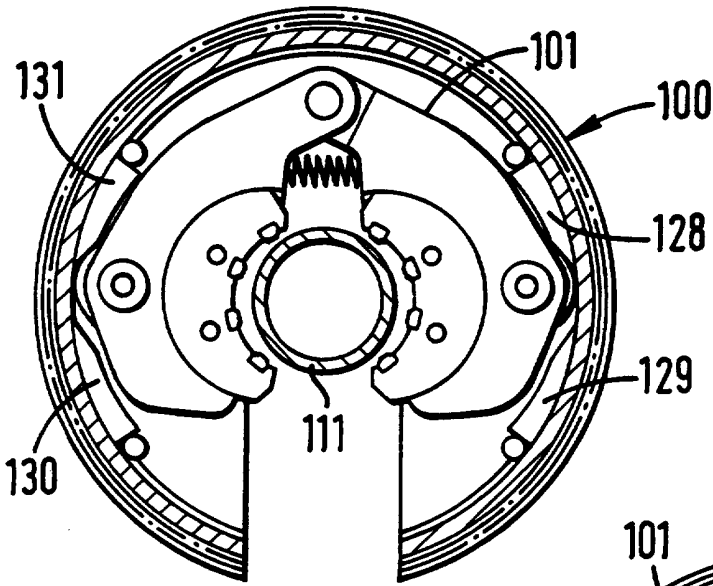

FIG. 4

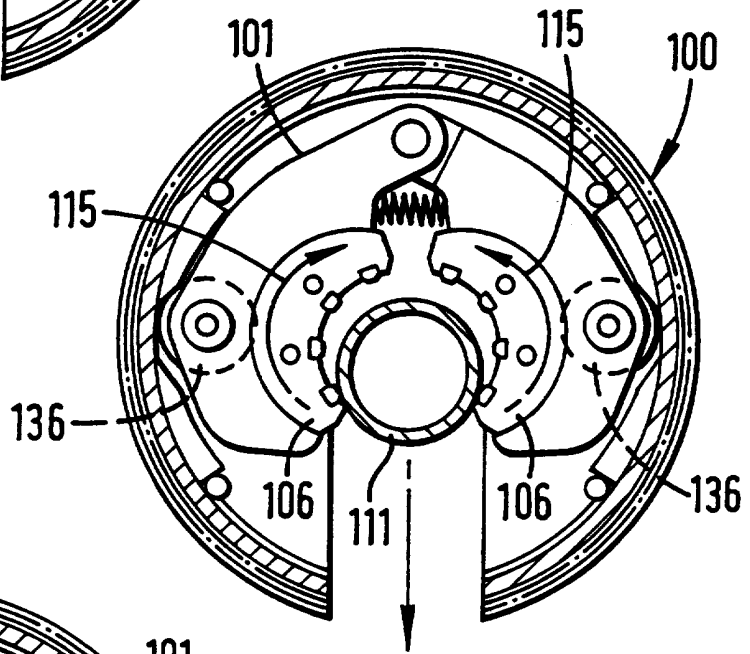

FIG. 5

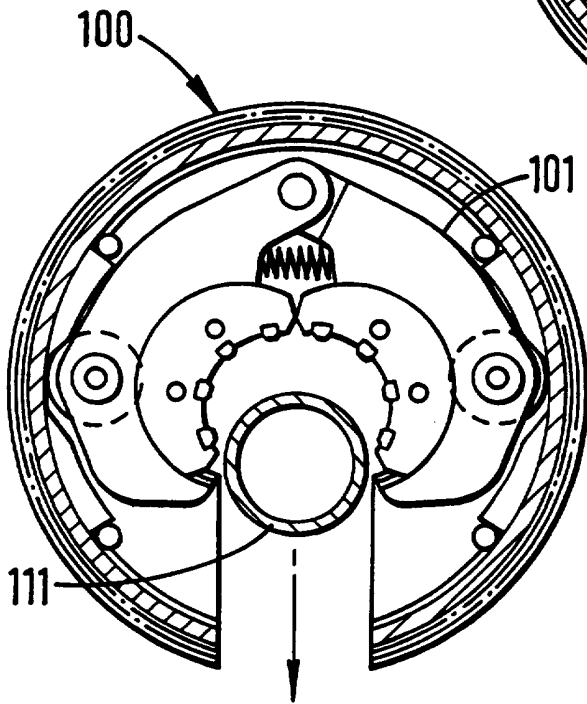
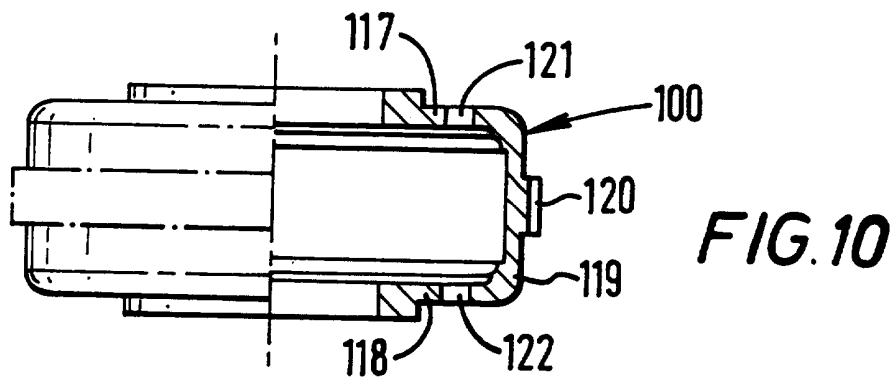
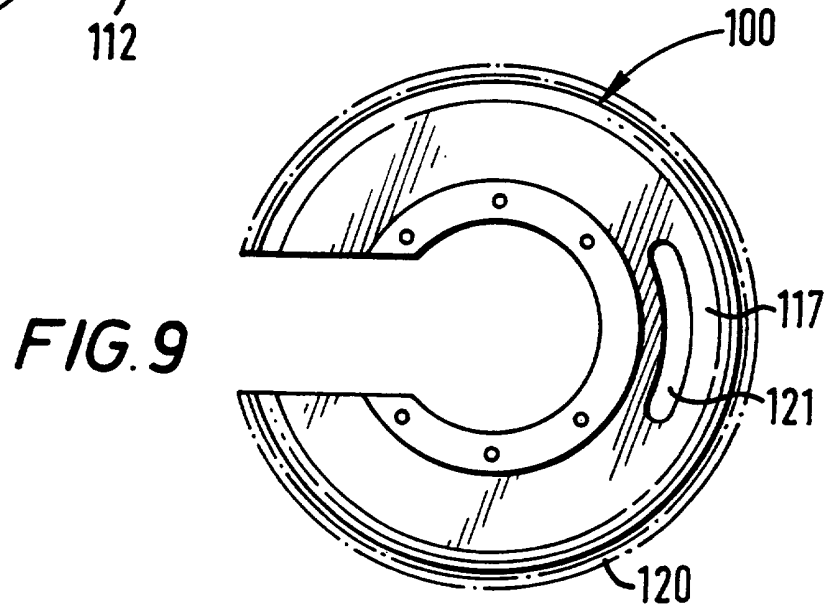
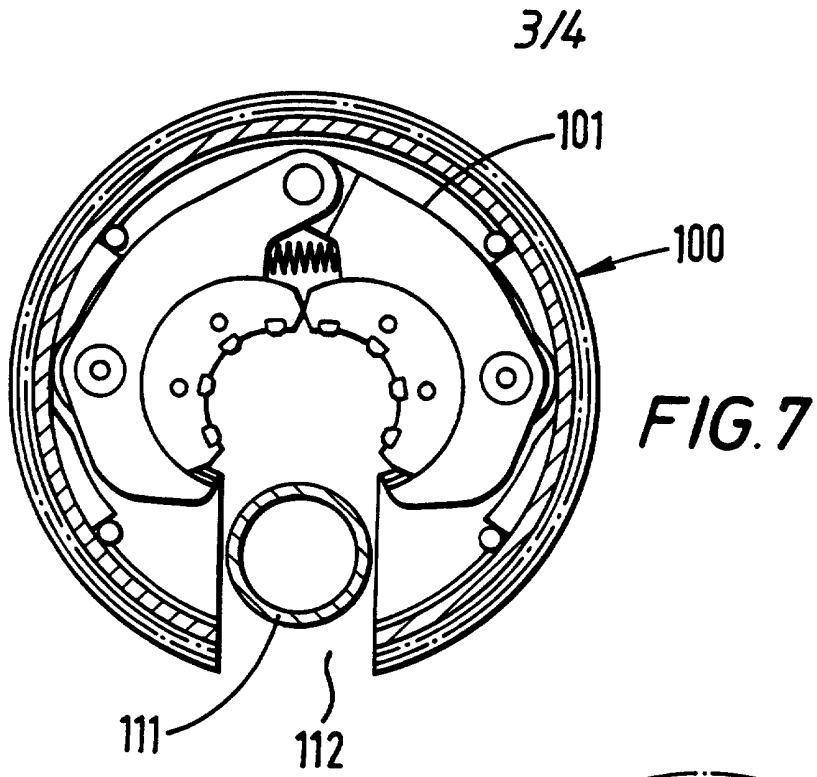

FIG. 6



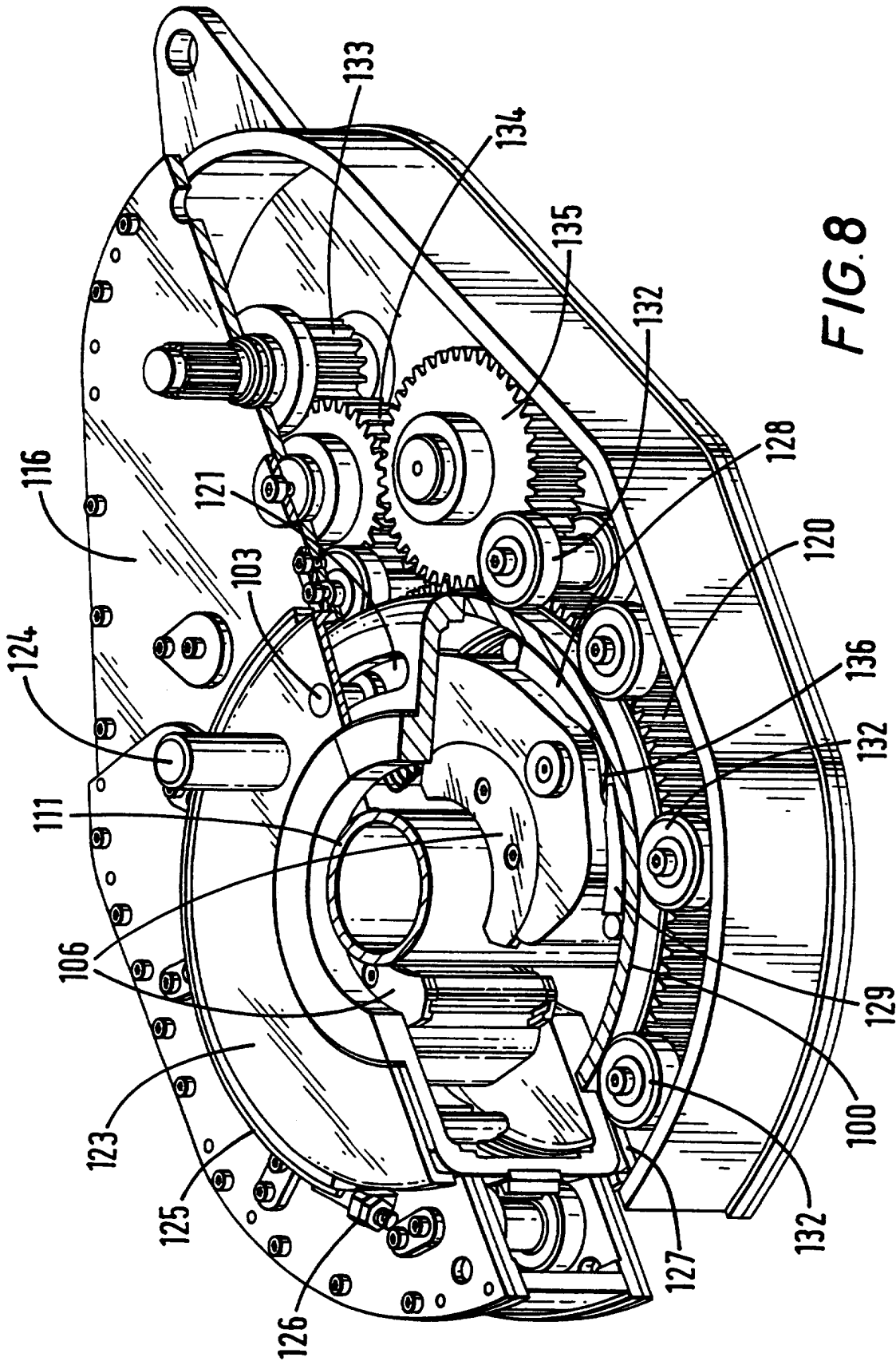

FIG. 8

Jaw Unit for use in a Tong

This invention relates to a jaw unit for use in a tong, a jaw assembly, and a tong fitted with such a jaw unit or jaw assembly.

5 During the construction of oil and gas wells it is necessary to connect and disconnect a large number of threaded tubulars, for example lengths of casing and drill pipe. This is generally effected by means of a tong which is a device which grips the tubular. The
10 tubular is then rotated either by rotating the tong manually or, more usually by a hydraulic motor.

The cost of running a drilling rig is extremely high and consequently there is tremendous pressure to develop tools which can be operated more rapidly than
15 previous tools. It is also important that such tools are reliable even under the extreme environmental conditions where drilling often takes place.

With this in mind the present invention provides a jaw unit for use in a tong, which jaw unit comprises a
20 jaw holder and a jaw movable with respect to said jaw holder, characterised in that said jaw is slidably mounted on said jaw holder.

Preferably, said jaw is slidable with respect to said jaw holder about an arcuate path.

25 Advantageously, said jaw has a gripping surface which is substantially arcuate for gripping the surface of a tubular and the centre of curvature of such arcuate path lies between the centre of curvature of said gripping surface and said arcuate path.

30 The gripping surface may be a continuous surface or defined by several spaced apart gripping elements.

Preferably, the centre of curvature of said arcuate path lies between the centre of curvature of said gripping surface and said gripping surface.

35 Advantageously, the centre of curvature of said

arcuate path is substantially midway between the centre of curvature of said gripping surface and said gripping surface.

5 Preferably, one of said jaw and said jaw holder is provided with an arcuate track which defines said arcuate path, and the other of said jaw and said jaw holder is slidably mounted in said arcuate track.

10 The present invention also provides a jaw assembly comprising two jaw units in accordance with the present invention.

Preferably, said jaw units are mounted for pivotal movement about a common pivot shaft.

Advantageously, said jaw assembly includes means which bias said jaw units apart.

15 The present invention also provides a rotary fitted with a jaw unit in accordance with the present invention, a rotary fitted with a jaw assembly in accordance with the present invention, and a tong fitted with a rotary in accordance with the present invention.

20 * * *

Traditionally, a rotary is made from three separate pieces, i.e. a top section, a bottom section and a peripheral wall. Each section has to be carefully made and machined to ensure that all three sections can be bolted together. This involves considerable skilled work and consequently a rotary is a relatively expensive item.

In order to help overcome this the present invention provides a rotary formed as a one piece casting.

30 * * *

One of the features of existing tongs is that their rotaries are difficult to furnish. Thus, routine maintenance usually involves dismantling the whole rotary, checking the parts and reassembling the whole. Whilst this is a straightforward procedure in the clean condi-

35

tions of a workshop it can be problematic when carried out in a muddy field, in sand or in snow. The present invention aims to help solve this problem and provides a rotary which comprises a top section, a bottom section, and a peripheral wall therebetween, characterised in that at least one of said top section and said bottom section is provided with an elongate slot which, when said rotary is in use, accommodates a pivot shaft on which a jaw assembly can be pivotally mounted.

5

10

* * *

Jaw holders and jaws for tongs are traditionally machined from the solid. This is a comparatively expensive procedure. The present invention proposes to make such parts from a stack of individually cut laminations.

15

Conveniently, the laminations could be cut with a lazer from sheet steel. The stack of laminations could then, for many purposes, be simply welded together along their sides and/or bolted together and/or glued together. Mass produced laminations are relatively inexpensive and an acceptable final product can be produced at a fraction of the cost of a product machined from the whole.

20

25

30

35

For a better understanding of the present invention reference will now be made, by way of example, to the accompanying drawings, in which:-

5 Fig. 1 is a schematic plan view, partly in section, showing a rotary fitted with a jaw assembly in accordance with the present invention ready to receive a tubular;

Fig. 2 shows the tubular entering the jaw assembly;

10 Fig. 3 shows the tubular nearing its final position in the jaw assembly;

Fig. 4 shows the tubular in its final position;

Fig. 5 shows the tubular being released from the jaw assembly;

Fig. 6 shows the tubular leaving the jaw assembly;

15 Fig. 7 shows the tubular leaving the rotary;

Fig. 8 is a perspective view, with part cut away, showing a tong in accordance with the present invention;

Fig. 9 is a top plan view of the rotary which forms part of the tong shown in Fig. 8; and

20 Fig. 10 is a side view, partly in cross-section and partly in elevation, showing the rotary of Fig. 9.

Referring to Figs. 1 to 7 of the drawings there is shown a rotary which is generally identified by the reference numeral 100.

25 The rotary 100 is fitted with a jaw assembly 101 which comprises two jaw units 102 which are pivotally mounted on a pivot shaft 103 and which are biased apart by a spring 104.

30 Each jaw unit 102 comprises a jaw holder 105 on which is mounted a jaw 106 the radially inner surface of which is provided with a plurality of gripping elements 107 which together define a gripping surface which is substantially arcuate.

35 The jaw holders 105 are provided with an arcuate track 108 and the jaw 106 is slidably mounted on the

arcuate track 108 so that the jaws 106 can slide along the arcuate track 108 relative to the jaw holder 105.

Thus, when the jaw holders 105 are in the position shown in Figs. 1 to 7 the jaws 106 can slide along an arcuate path having a centre of curvature at a point 109 which is radially inwardly of the gripping surface of the gripping elements 107 but to one side of the centre 110 of the rotary 100.

In use, when it is desired to grip a tubular 111, for example a length of casing, the tubular 111 is introduced into the rotary 100 through the opening 112. This is shown in Fig. 1. It should be noted that the jaws 106 have been displaced to a position where they touch one another at point 113. This position can be achieved by displacing the jaws 106 manually. However, in practice the jaws 106 will normally be found in this position as a result of the exit of the previous tubular as will be described more fully hereinafter.

Fig. 2 shows the tubular 111 entering the jaw assembly 101, it will be noted that part of the arcuate track 108 is visible.

Fig. 3 shows the tubular 111 contacting the jaws 106. As the tubular 111 is further advanced towards the centre 110 of the rotary 100 the jaws 106 are displaced in the direction of the arrows 114 until they come to rest in the position shown in Fig. 4. It will be noted that the arcuate track 108 is no longer visible.

The rotary 100 is then rotated clockwise (as viewed in Fig. 4) to advance the jaws 106 into gripping engagement with the tubular 111 as will be described hereinafter. The gripping surface substantially conforms to the surface of the tubular 111 and thus has a centre of curvature at the centre 110 of the rotary 100 when the jaws 106 are applied. After the tubular 111 has been rotated and tightened to the required torque the rotary

100 is rotated anti-clockwise to allow the jaws 106 to move away from the tubular 111 under the influence of spring 104.

5 The tubular 111 is then moved towards the opening 112. As it moves it engages the jaws 106 and displaces them in the direction of the arrows 115 so that they occupy the position shown in Fig. 6 which is identical to Figs. 1, 2 and 7.

10 Fig. 7 shows the tubular 111 leaving the rotary 100.

It will be appreciated that the jaw assembly 101 is extremely simple, quick to use and relatively inexpensive to manufacture and maintain.

* * *

15 Referring now to Fig. 8, the rotary 100 is shown fitted in a tong 116.

20 As shown in Fig. 9 and 10, the rotary 100 is formed as a one piece casting which comprises a top section 117, a bottom section 118, and a peripheral wall 119 on which is formed a toothed track 120.

Both the top section 117 and the bottom section 118 are provided with an elongate slot 121, 122 respectively. Each elongate slot 121, 122 has its centre of curvature on the centre of rotation of the rotary 100.

25 As can be seen from Fig. 8, the upper part of the pivot shaft 103 which forms the pivot point for the two jaw units 102 projects upwardly through the elongate slot 121 whilst the lower part of the pivot shaft 103 projects downwardly through the elongate slot 122.

30 The upper part of the pivot shaft 103 is secured to a disk 123 which is provided with a handle 124.

A friction member 125 extends circumjacent the disk 123 and is held thereagainst by a tensioner 126.

35 A disk 127 similar to disk 123 is mounted below the rotary 100 and is also engaged by a second friction

member similar to friction member 125.

As can be seen in Fig. 8 and Figs. 1 to 7, the sides of the rotary 100 are provided with cams 128, 129, 130 and 131 which are screwed to the rotary 100. The rotary 100 is located in the tong 116 by nine guide rolls 132, five of which are visible in Fig. 8. The guide rolls 132 each have an upper and a lower roller which bears against the peripheral wall 119 of the rotary 100 above and below the toothed track 120 respectively.

The rotary 100 is driven by a hydraulic motor (not shown) which acts through a gear train which includes gear wheels 133, 134 and 135.

In Fig. 8 the tubular 111 is about to be gripped. (This corresponds to the position shown in Fig. 4.) The hydraulic motor (not shown) is actuated to rotate gear wheels 133, 134 and 135 which in turn rotate the rotary 100 in a clockwise direction. However, whilst the rotary 100 rotates the disk 123 is restrained by the friction member 125. The disk 123 in turn restrains the pivot shaft 103 and the jaw assembly 101. Because the jaw assembly 101 is restrained the jaw units 102 ride up on the cams 128, 130 which urge the jaws 106 into the tubular 111 until either the pivot shaft 103 engages the end of the elongate slot 121 (or the forces between the tubular 111, the jaw units 102 and the cams 128, 130 are sufficiently high) at which time the disk 123 rotates in unison with the rotary 100 against the friction member 125. It will be noted that because the centres of curvature of the gripping elements 107 and the arcuate track 108 do not coincide the jaw holders 105 do not spin around the jaws 106 although means to limit the sliding movement of the jaws 102 relative to their jaw holders 105 could be provided if desired.

When the tubular 111 has been tightened to the

desired torque the hydraulic motor is reversed to rotate the rotary 100 anti-clockwise. The jaws 106 are normally firmly engaged in the tubular 111 and hence the rotary 100 rotates relative to the jaw assembly 101 so that the jaw holder 105 returns to the position shown in Fig. 8. Means may be provided to prevent the jaw holders 105 engaging the cams 129 and 131.

It will be noted that the jaw holders 105 are each provided with a roller 136 which engages the cams 128, 129, 130 and 131.

If it is desired to rotate the tubular 111 in the opposite direction then the rotary 100 is simply rotated in the opposite direction causing the rollers 136 to roll along the cams 129, 131.

It will be noted that the entire jaw assembly 101 can be removed from the rotary 100 by simply removing the pivot shaft 103 and withdrawing the jaw units 102. The cams 128, 129, 130, 131 can then be readily replaced if desired and the jaw units 102 refitted or replaced if desired. Such changes would generally be made when changing the diameter of the tubular being run.

25

30

35

CLAIMS:

1. A jaw unit (102) for use in a tong, which jaw unit (102) comprises a jaw holder (105) and a jaw (106) movable with respect to said jaw holder (105),
5 characterised in that said jaw (106) is slidably mounted on said jaw holder (105).
2. A jaw unit as claimed in Claim 1, wherein said jaw (106) is slidable with respect to said jaw holder (105) about an arcuate path (108).
- 10 3. A jaw unit as claimed in Claim 2, wherein said jaw (106) has a gripping surface which is substantially arcuate for gripping the surface of a tubular (111) and the centre of curvature (109) of such arcuate path (108) lies between the centre of curvature of said gripping
15 surface and said arcuate path (108).
4. A jaw unit as claimed in Claim 3, wherein the centre of curvature (109) of said arcuate path (108) lies between the centre of curvature of said gripping surface and said gripping surface.
- 20 5. A jaw unit as claimed in Claim 4, wherein the centre of curvature (109) of said arcuate path (108) is substantially midway between the centre of curvature of said gripping surface and said gripping surface.
6. A jaw unit as claimed in any of Claims 2 to 5,
25 wherein one of said jaw (106) and said jaw holder (105) is provided with an arcuate track (108) which defines said arcuate path, and the other of said jaw (106) and said jaw holder (105) is slidably mounted in said arcuate track (108).
- 30 7. A jaw assembly comprising two jaw units (102) as claimed in any preceding claim.
8. A jaw assembly as claimed in Claim 7, wherein said jaw units (102) are mounted for pivotal movement about a common pivot shaft (103).
- 35 9. A jaw assembly as claimed in Claim 7 or 8, includ-

ing means (104) which bias said jaw units (102) apart.

10. A rotary (100) fitted with a jaw unit as claimed in any of Claims 1 to 6, or a jaw assembly as claimed in Claim 7, 8 or 9.

5 11. A tong fitted with a rotary (100) as claimed in Claim 10.

* * *

12. A rotary formed as a one piece casting.

* * *

10 13. A rotary (100) which comprises a top section (117), a bottom section (118), and a peripheral wall (119) therebetween, characterised in that at least one of said top section (117) and said bottom section (118) is provided with an elongate slot (121, 122) which, when
15 said rotary (100) is in use, accommodates a pivot shaft (103) on which a jaw assembly (101) is pivotally mounted.

* * *

14. A jaw holder characterised in that it comprises a
20 plurality of laminations.

15. A jaw characterised in that it comprises a plurality of laminations.

* * *

25

30

35



Application No: GB 9702474.9
Claims searched: 1-11

Examiner: Vaughan Phillips
Date of search: 18 March 1997

Patents Act 1977
Search Report under Section 17

Databases searched:

UK Patent Office collections, including GB, EP, WO & US patent specifications, in:
UK Cl (Ed.O): B3N
Int Cl (Ed.6): E21B
Other: Online: WPI

Documents considered to be relevant:

Category	Identity of document and relevant passage	Relevant to claims
X	GB 2049517 A (ECKEL) see jaws 32 slidable in holder 94	1 at least

X	Document indicating lack of novelty or inventive step	A	Document indicating technological background and/or state of the art.
Y	Document indicating lack of inventive step if combined with one or more other documents of same category.	P	Document published on or after the declared priority date but before the filing date of this invention.
&	Member of the same patent family	E	Patent document published on or after, but with priority date earlier than, the filing date of this application.