



- (51) International Patent Classification:
B22D 15/04 (2006.01) *B22D 30/00* (2006.01)
- (21) International Application Number:
PCT/CA2012/001019
- (22) International Filing Date:
5 November 2012 (05.11.2012)
- (25) Filing Language: English
- (26) Publication Language: English
- (30) Priority Data:
61/555,522 4 November 2011 (04.11.2011) US
- (71) Applicant: **HATCH LTD.** [CA/CA]; 2800 Speakman Drive, Sheridan Science & Technology Park, Mississauga, Ontario L5K 2R7 (CA).
- (72) Inventors: **TROVANT, Michael**; 61 Markbrook Lane, Unit 1407, Toronto, Ontario M9V 5E7 (CA). **BROWN, Lucas Alexander**; 19 Mack Street, Kingston, Ontario L7L 1N7 (CA). **CESTA, Tony**; 41 Ashburnham Road, Toronto, Ontario M6H 2K4 (CA). **STOKMAN-CONNELL, Katharine Elizabeth**; 2470 The Promenade, Oakville, Ontario L6H 6J7 (CA). **MCCAFFREY, Felim Patrick**; 701 King Street West, Unit 212, Toronto, Ontario M5V 2W7 (CA).

- (74) Agent: **BERESKIN & PARR LLP/S.E.N.C.R.L., S.R.L.**; 40th Floor, 40 King Street West, Scotia Plaza, Toronto, Ontario M5H 3Y2 (CA).
- (81) Designated States (*unless otherwise indicated, for every kind of national protection available*): AE, AG, AL, AM, AO, AT, AU, AZ, BA, BB, BG, BH, BN, BR, BW, BY, BZ, CA, CH, CL, CN, CO, CR, CU, CZ, DE, DK, DM, DO, DZ, EC, EE, EG, ES, FI, GB, GD, GE, GH, GM, GT, HN, HR, HU, ID, IL, IN, IS, JP, KE, KG, KM, KN, KP, KR, KZ, LA, LC, LK, LR, LS, LT, LU, LY, MA, MD, ME, MG, MK, MN, MW, MX, MY, MZ, NA, NG, NI, NO, NZ, OM, PA, PE, PG, PH, PL, PT, QA, RO, RS, RU, RW, SC, SD, SE, SG, SK, SL, SM, ST, SV, SY, TH, TJ, TM, TN, TR, TT, TZ, UA, UG, US, UZ, VC, VN, ZA, ZM, ZW.
- (84) Designated States (*unless otherwise indicated, for every kind of regional protection available*): ARIPO (BW, GH, GM, KE, LR, LS, MW, MZ, NA, RW, SD, SL, SZ, TZ, UG, ZM, ZW), Eurasian (AM, AZ, BY, KG, KZ, RU, TJ, TM), European (AL, AT, BE, BG, CH, CY, CZ, DE, DK, EE, ES, FI, FR, GB, GR, HR, HU, IE, IS, IT, LT, LU, LV, MC, MK, MT, NL, NO, PL, PT, RO, RS, SE, SI, SK, SM, TR), OAPI (BF, BJ, CF, CG, CI, CM, GA, GN, GQ, GW, ML, MR, NE, SN, TD, TG).

[Continued on next page]

(54) Title: COOLING OF CHILL MOLDS USING BAFFLES

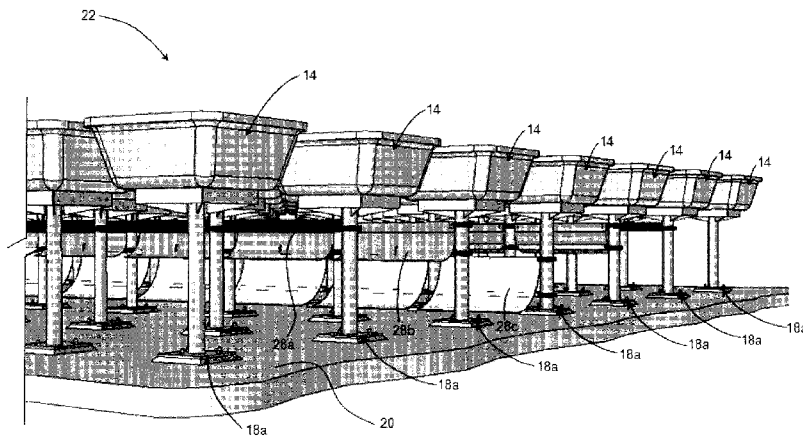

Figure 4

(57) Abstract: A chill mold is used to cool molten material to form a casting. A support holds the chill mold so that a bottom of the chill mold is elevated. A baffle is arranged to divert a generally horizontal flow of cooling air upwardly to impinge the bottom of the chill mold. A plurality of chill molds may be aligned generally in a row, and at least one fan may be arranged at an end of the row to direct the flow of cooling air underneath the chill molds. The size and the vertical position of the baffles may be varied along the row, so as to generally equalize convective cooling rates among the chill molds in the row.



Published:

— *with international search report (Art. 21(3))*

COOLING OF CHILL MOLDS USING BAFFLES

Cross-Reference to Related Application

[0001] This application claims priority to U.S. Provisional Application No. 61/555,522 filed on November 4, 2011, the entire contents of which are hereby incorporated herein by reference.

Technical Field

[0002] The present disclosure relates to an arrangement for cooling chill molds, and particularly to baffles for diverting the flow of cooling air to impinge chill molds.

Background

[0003] The following paragraphs are not an admission that anything discussed in them is prior art or part of the knowledge of persons skilled in the art.

[0004] In some smelting operations, molten material may be cooled by forced convection to form castings. For example, at a calcium carbide smelter plant, molten calcium carbide may be tapped from a furnace at approximately 2000°C into cast iron chill molds. In other processes, molten material may be tapped from a furnace into an intermediate transfer vessel, and subsequently poured into chill molds.

[0005] In either case, the chill molds may then be moved to a dedicated cooling area. Fans may there be used to direct flows of cooling air to cool groups of the chill molds.

Summary of the Disclosure

[0006] The following summary is intended to introduce the reader to the more detailed description that follows and not to define or limit the claimed subject matter.

[0007] In a forced convection process, such as described above, the cooling time for a chill mold may be up to 40 hours or more. Due to the

- 2 -

relatively long cooling period for each chill mold, large cooling areas may be required to achieve satisfactory throughput, which increases both capital and operating costs. Furthermore, flow velocity from cooling fans tends to decay with distance from the fan. As a result, chill molds furthest from the fans may be subject to reduced convective cooling, requiring a longer cooling period.

[0008] According to an aspect of the present disclosure, an apparatus for cooling a molten material may include: a chill mold having a bottom and at least one sidewall rising up from the bottom defining together a vessel for holding the molten material therein to form a casting; a support having a base that holds the support generally upright on a floor surface and a frame positioned above the base adapted to receive and hold the chill mold so that the bottom is elevated relative to the base; and a baffle arranged underneath the frame and adapted to divert a generally horizontal flow of cooling air upwardly to impinge the bottom of the chill mold when supported on the frame.

[0009] The support may include a column extending between the base and the frame. The baffle may be mounted to the column. The base may be mounted to the floor surface. A vertical position of the baffle may be adjustable. A guiding surface of the baffle may be curved so that the flow of cooling air impinges the bottom generally vertically.

[0010] According to another aspect of the present disclosure, a system for cooling a molten material may include: a plurality of chill molds aligned generally in a row, each of the chill molds having a bottom and at least one sidewall defining together a vessel for holding the molten material therein to form a casting; at least one fan arranged at an end of the row, and adapted to direct a generally horizontal flow of cooling air underneath the chill molds; and a plurality of baffles arranged underneath at least a portion of the chill molds and adapted to divert the flow of cooling air upwardly to impinge the bottoms of at least some of the chill molds.

[0011] Each of the baffles may be associated with a respective one of the chill molds. The baffles may vary in size. The baffles may be progressively larger the further away the baffles are from the fan. Vertical positions of the

- 3 -

baffles may vary. At least some of the baffles may be vertically offset from one another so that each diverts a portion of the flow of cooling air while permitting the remaining flow to pass on to the next baffle.

[0012] The at least one fan may include first and second fans arranged at respective first and second ends of the row. The first and second fans may direct respective first and second flows of cooling air in generally opposing directions. The baffles being closer to the first fan may be arranged to divert the first flow of cooling air, and the baffles being closer to the second fan may be arranged to divert the second flow of cooling air.

[0013] The system may include a plurality of supports. Each of the supports may include a base that holds the support generally upright on a floor surface, a frame positioned above the base adapted to receive and hold a respective one of the chill molds so that the bottom is elevated relative to the base, and a column extending between the base and the frame.

[0014] In another aspect of the present disclosure, a method of cooling a molten material may include: pouring the molten material in a plurality of chill molds, each of the chill molds having a bottom and at least one sidewall rising up from the bottom defining together a vessel for holding the molten material therein to form a casting; aligning the chill molds generally in a row; directing a generally horizontal flow of cooling air underneath the chill molds; and diverting the flow of cooling air upwardly so as to impinge the bottoms of at least some of the chill molds.

[0015] The step of diverting may include the flow of cooling air impinging bottoms of the chill molds generally vertically. The step of diverting may include arranging a plurality of baffles underneath some of the chill molds.

[0016] The method may further include varying a size of at least one of the baffles relative to the other baffles. The method may further include varying the size of the at least one of the baffles based on the distance of the baffle relative to a source of the flow of cooling air.

- 4 -

[0017] The method may further include varying a vertical position of at least one of the baffles relative to the other baffles. The step of varying may include arranging at least some of the baffles vertically offset from one another so that each diverts a portion of the flow of cooling air while permitting the remaining flow to pass on to the next baffle.

Brief Description of the Drawings

[0018] In order that the claimed subject matter may be more fully understood, reference will be made to the accompanying drawings, in which:

Figure 1 is a partial cutaway, perspective view of a furnace building and a mold cooling building;

Figure 2 is a schematic side view of a row of chill molds;

Figure 3 is a perspective upper view of a chill mold and a support according to an example;

Figure 4 is a perspective side view of a number of the chill molds and the supports of Figure 3 aligned in a row, and with baffles;

Figure 5 is a detailed side view of some of the chill molds, the supports and the baffles of Figure 4;

Figure 6 is a detailed end view of some of the chill molds, the supports and a first one of the baffles of Figure 4;

Figure 7 is a detailed end view of some of the chill molds, the supports and a second one of the baffles of Figure 4; and

Figure 8 is a detailed end view of some of the chill molds, the supports and a third one of the baffles of Figure 4.

Detailed Description

[0019] In the following description, specific details are set out to provide examples of the claimed subject matter. However, the examples described below are not intended to define or limit the claimed subject matter. It will

- 5 -

apparent to those skilled in the art that many variations of the specific examples may be possible within the scope of the claimed subject matter.

[0020] For simplicity and clarity of illustration, where considered appropriate, reference numerals may be repeated among the figures to indicate corresponding or analogous elements or steps.

[0021] Referring to Figure 1, an example of a smelting operation is shown to include a furnace building 10 and a mold cooling building 12. The exterior structure of the mold cooling building 12 has been partially removed to expose the interior.

[0022] In the furnace building 10, molten material may be tapped from a furnace (not shown), or otherwise poured (e.g., using an intermediate transfer vessel), into chill molds. The chill molds, identified by reference numeral 14, may then be transported from the furnace building 10 to a dedicated cooling area in the mold cooling building 12 using, for example, transport cars on rails 16.

[0023] In the mold cooling building 12, the chill molds 14 may be picked up using, for example, an overhead crane (not shown) and arranged on supports 18 so that the chill molds 14 are elevated off of a floor surface 20. As illustrated, the chill molds 14 are aligned in a series of rows 22, forming an array 24. Fans 26 located at ends of the rows 22 direct flows of cooling air at the chill molds 14. The chill molds 14 gradually cool, and the molten material therein forms castings. Once cooled, the chill molds 14 may be picked up by the overhead crane and transported elsewhere for further processing.

[0024] Referring now to Figure 2, the fans 26 may be arranged at either end of the row 22, and each directs a generally horizontal flow of cooling air, in opposing directions, underneath the chill molds 14. The fans 26 are selected to provide adequate velocity of the cooling air to the chill molds 14 located roughly in the middle between the fans 26. In other examples, only one of the fans 26 may be provided at one end of the row 22. Also, although seven of the chill

- 6 -

molds 14 are shown aligned in the row 22, it will be appreciated that the number of chill molds 14 provided in a row may vary.

[0025] Baffles 28 are arranged underneath the chill molds 14 to divert the flow of cooling air upwardly to impinge the chill molds 14. As illustrated, the baffles 28 are arranged to divert the flow of cooling air coming from the fan 26 that is the closest. Also, the baffles 28 are each shown to be associated with a particular one of the chill molds 14, whereas some of the chill molds 14 (the ones closest to the fans 26) do not have an associated baffle 28.

[0026] The supports 18 are shown as table-like structures which elevate the chill molds 14 above the floor surface 20. Although not shown in Figure 2, it will be appreciated that bottoms of each of the chill molds 14 are mostly exposed and unobstructed by the supports 18, so that the flow of cooling air from the fans 26 may be directed upwardly to impinge the chill molds 14 without substantial interference by the supports 18.

[0027] Referring to Figure 3, the chill mold 14, which is shown in ghost lines to expose further details of another support 18a, includes a bottom 30 and sidewalls 32 rising up from the bottom 30 to form a vessel 34 for holding the molten material. During cooling, the bottom 30 of the chill mold 14 may remain significantly hotter than the sidewalls 32 for most of the cooling duration. Accordingly, as described herein, the rate of convective cooling may be accelerated by impinging the bottom 30 with cooling air, as opposed to directing cooling air at one of the sidewalls 32.

[0028] In the example illustrated, the support 18a includes a base 36 that holds the support 18a generally upright on the floor surface 20. The base 36 may be mounted to the floor surface 20 using fasteners, for example. A frame 38 is positioned above the base 36, and a column 40 extends between the base 36 and the frame 38. As illustrated, the column 40 may be generally cylindrical, and with only one of the columns 40 supporting each of the chill molds 14, so as to minimize restriction on the flow of cooling air.

- 7 -

[0029] The frame 38 receives and holds the chill mold 14 so that the bottom 30 is elevated relative to the base 36 and is raised off of the floor surface 20. In the example illustrated, the frame 38 includes a square-shaped outer structure 42 and cross members 44 extending between a top of the column 40 and the outer structure 42. Again, with this configuration, the bottom 30 of the chill mold 14 is mostly exposed and unobstructed by the frame 38 to minimize interference on the flow of cooling air impinging the bottom 30.

[0030] Referring now to Figures 4 and 5, three different baffles, identified by reference numerals 28a, 28b and 28c, are shown arranged underneath some of the chill molds 14 in the row 22 to divert the flow of cooling air upwardly.

[0031] In the example illustrated, the baffles 28a, 28b and 28c each have a guiding surface, facing the fan 26, that is curved through approximately 90° to divert the horizontal flow into a vertical direction so that the flow of cooling air impinges the bottom of the chill molds generally vertically. In some examples, each of the baffles 28a, 28b and 28c may consist of a relatively thin, curved plate, which may be formed of steel.

[0032] Further views of the baffles 28a, 28b, 28c are provided in Figures 6, 7 and 8, respectively.

[0033] As mentioned above, there tends to be a progressive decay in velocity as a flow of air moves away from a fan. To counteract this decay, the area of the baffles may be varied, with the largest baffle located furthest away from the fan where velocity of the cooling air is lowest.

[0034] In the example illustrated, the baffles 28a, 28b, 28c are progressively larger the further away they are from the fan 26. A larger area may direct proportionately more of the flow of cooling air to the chill molds 14 located further away from the fan 26, so as to generally equalize convective cooling rates among the chill molds 14 in the row 22.

[0035] For example, for illustration purposes and not intended to be limiting, if each of the chill molds 14 is 1.5 m long, 1.5 m wide and 0.9 m tall,

- 8 -

and a center-to-center distance (identified as reference numeral 46 in Figure 5) is 3.0 m, then the size of baffle 28a may be 1.8 m wide by 0.16 m tall (0.288 m²), the size of the baffle 28b may be 1.8 m wide by 0.56 m tall (1.088 m²), and the size of the baffle 28c may be 1.8 m wide by 0.86 m tall (1.548 m²).

[0036] In the example illustrated, the baffles 28a, 28b, 28c are mounted to the column 40 of the supports 18a of adjacent rows using collars 48. The collars 48 may be adjustable so that the vertical position of the baffles 28a, 28b, 28c on the column 40 may be varied. For example, fasteners may be used to constrict the collars 48 to circumferentially engage the column 40 and fix its position thereon.

[0037] With continued reference to Figures 6, 7 and 8, a bottom edge 50b of the baffle 28b is vertically offset below a bottom edge 50a of the baffle 28a, so that the baffle 28a diverts a portion of the flow of cooling air while permitting the remaining flow to pass on to the baffles 28b, 28c. Similarly, a bottom edge 50c of the baffle 28c is vertically offset below a bottom edge 50b of the baffle 28b, so that the baffle 28b diverts a portion of the flow of cooling air while permitting the remaining flow to pass on to the baffle 28c.

[0038] It will be appreciated by those skilled in the art that many variations are possible within the scope of the claimed subject matter. The examples that have been described above are intended to be illustrative and not defining or limiting.

CLAIMS

We claim:

1. An apparatus for cooling a molten material, comprising:
 - a chill mold having a bottom and at least one sidewall rising up from the bottom defining together a vessel for holding the molten material therein to form a casting;
 - a support having a base that holds the support generally upright on a floor surface and a frame positioned above the base adapted to receive and hold the chill mold so that the bottom is elevated relative to the base; and
 - a baffle arranged underneath the frame and adapted to divert a generally horizontal flow of cooling air upwardly to impinge the bottom of the chill mold when supported on the frame.
2. The apparatus of claim 1, wherein the support comprises a column extending between the base and the frame.
3. The apparatus of claim 2, wherein the baffle is mounted to the column.
4. The apparatus of any one of claims 1 to 3, wherein the base is mounted to the floor surface.
5. The apparatus of any one of claims 1 to 4, wherein a vertical position of the baffle is adjustable.
6. The apparatus of any one of claims 1 to 5, wherein a guiding surface of the baffle is curved so that the flow of cooling air impinges the bottom generally vertically.
7. A system for cooling a molten material, comprising:
 - a plurality of chill molds aligned generally in a row, each of the chill molds having a bottom and at least one sidewall defining together a vessel for holding the molten material therein to form a casting;

- 10 -

at least one fan arranged at an end of the row, and adapted to direct a generally horizontal flow of cooling air underneath the chill molds; and
a plurality of baffles arranged underneath at least a portion of the chill molds and adapted to divert the flow of cooling air upwardly to impinge the bottoms of at least some of the chill molds.

8. The system of claim 7, wherein each of the baffles is associated with a respective one of the chill molds.

9. The system of claim 8, wherein the baffles vary in size.

10. The system of claim 9, wherein the baffles are progressively larger the further away the baffles are from the fan.

11. The system of any one of claims 7 to 10, wherein vertical positions of the baffles vary.

12. The system of claim 11, wherein at least some of the baffles are vertically offset from one another so that each diverts a portion of the flow of cooling air while permitting the remaining flow to pass on to the next baffle.

13. The system of any one of claims 7 to 12, wherein the at least one fan comprises first and second fans arranged at respective first and second ends of the row, the first and second fans directing respective first and second flows of cooling air in generally opposing directions.

14. The system of claim 13, wherein the baffles being closer to the first fan are arranged to divert the first flow of cooling air, and the baffles being closer to the second fan are arranged to divert the second flow of cooling air.

15. The system of any one of claims 7 to 14, further comprising a plurality of supports, each of the supports comprising a base that holds the support generally upright on a floor surface, a frame positioned above the base adapted to receive and hold a respective one of the chill molds so that the bottom is

elevated relative to the base, and a column extending between the base and the frame.

16. A method of cooling a molten material, comprising:

pouring the molten material in a plurality of chill molds, each of the chill molds having a bottom and at least one sidewall rising up from the bottom defining together a vessel for holding the molten material therein to form a casting;

aligning the chill molds generally in a row;

directing a generally horizontal flow of cooling air underneath the chill molds; and

diverting the flow of cooling air upwardly so as to impinge the bottoms of at least some of the chill molds.

17. The method of claim 16, wherein the step of diverting comprises the flow of cooling air impinging bottoms of the chill molds generally vertically.

18. The method of claim 16 or 17, wherein the step of diverting comprises arranging a plurality of baffles underneath some of the chill molds.

19. The method of claim 18, further comprising varying a size of at least one of the baffles relative to the other baffles.

20. The method of claim 19, further comprising varying the size of the at least one of the baffles based on the distance of the baffle relative to a source of the flow of cooling air.

21. The method of any one of claims 18 to 20, further comprising varying a vertical position of at least one of the baffles relative to the other baffles.

22. The method of claim 21, wherein the step of varying comprises arranging at least some of the baffles vertically offset from one another so that each diverts a portion of the flow of cooling air while permitting the remaining flow to pass on to the next baffle.

- 12 -

23. An apparatus, a system or a method comprising any combination of one or more of the features described above and/or claimed above and/or illustrated in the drawings.

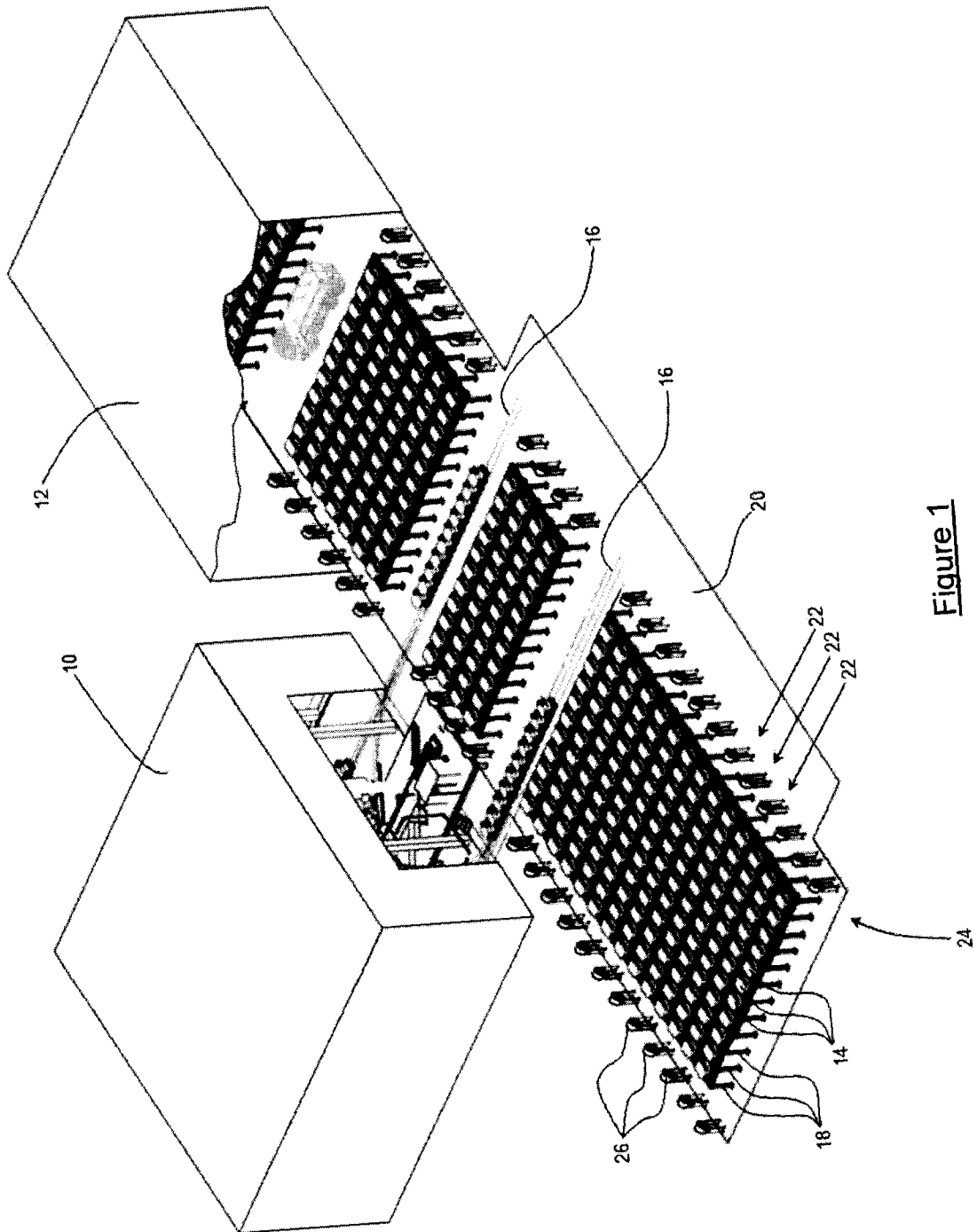

Figure 1

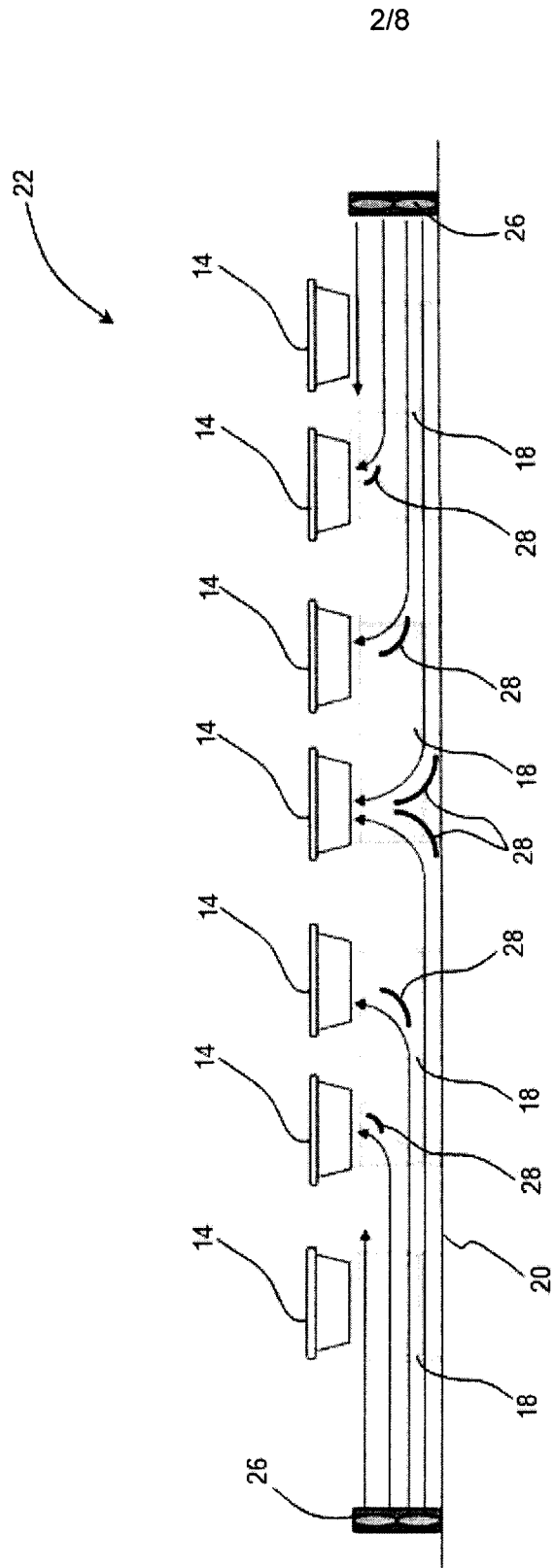

Figure 2

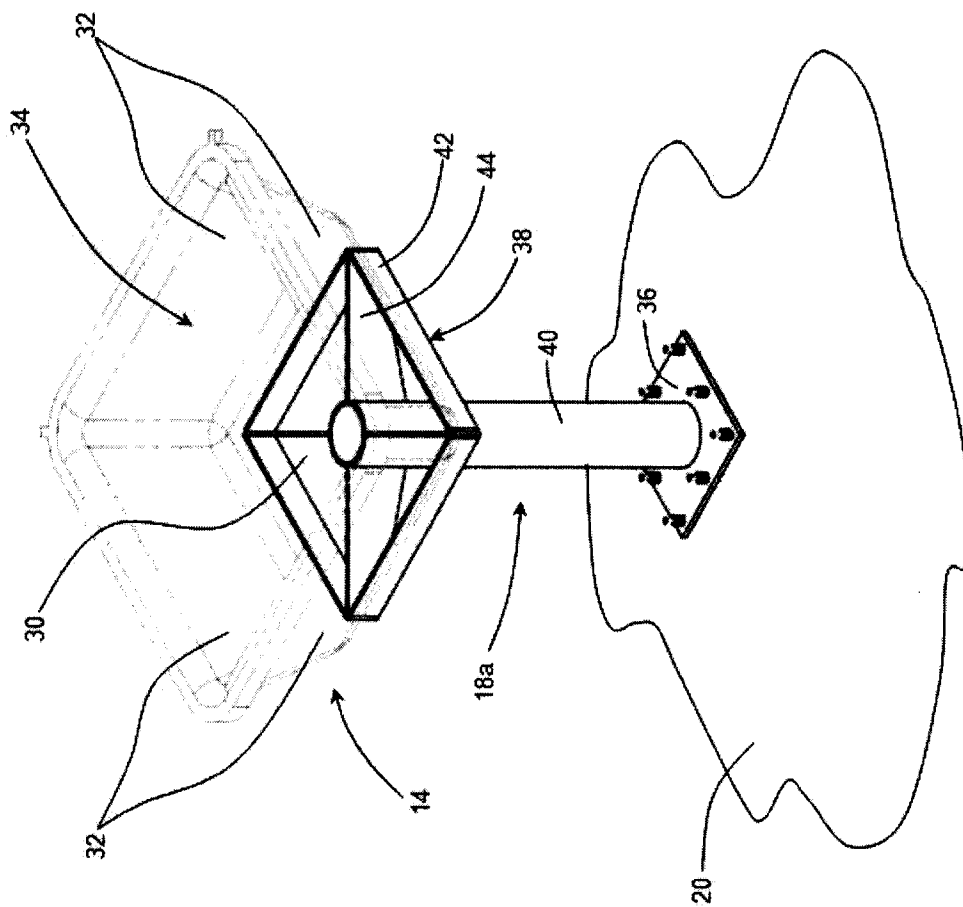

Figure 3

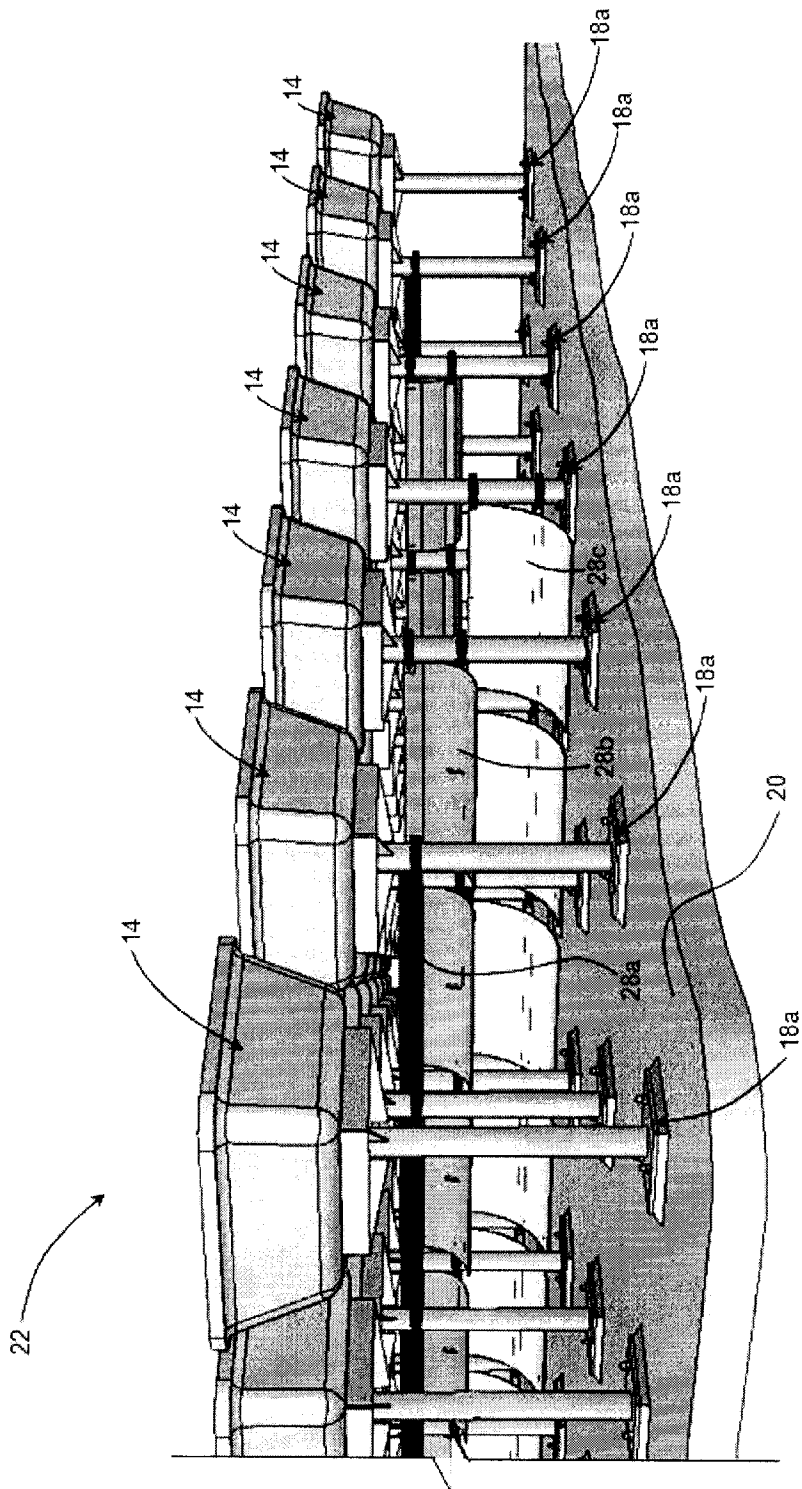

Figure 4

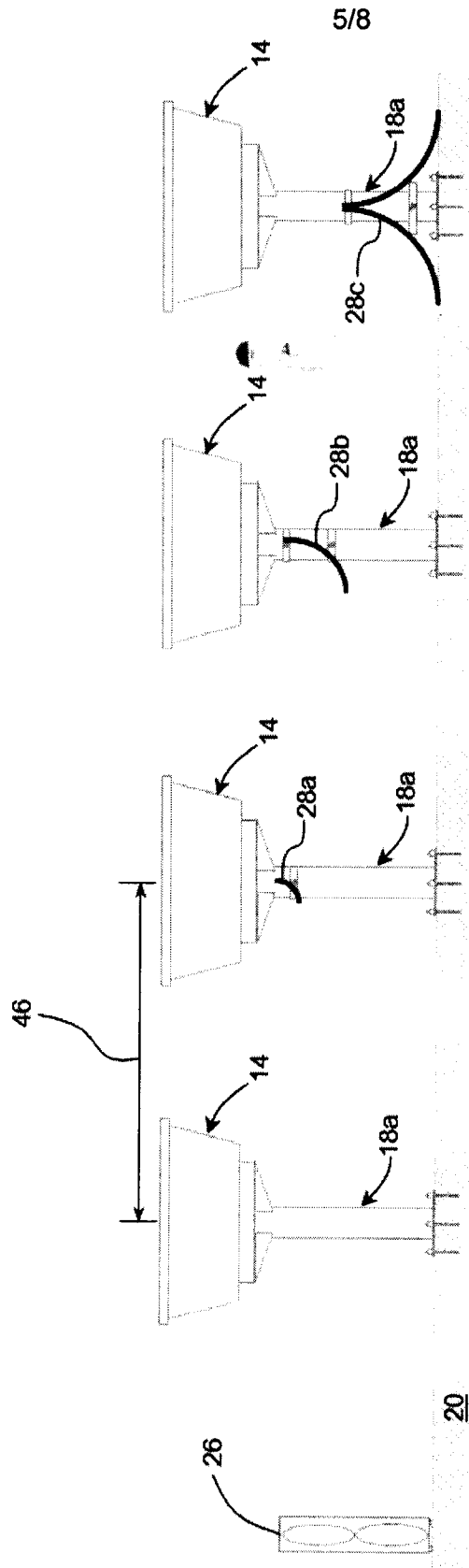

Figure 5

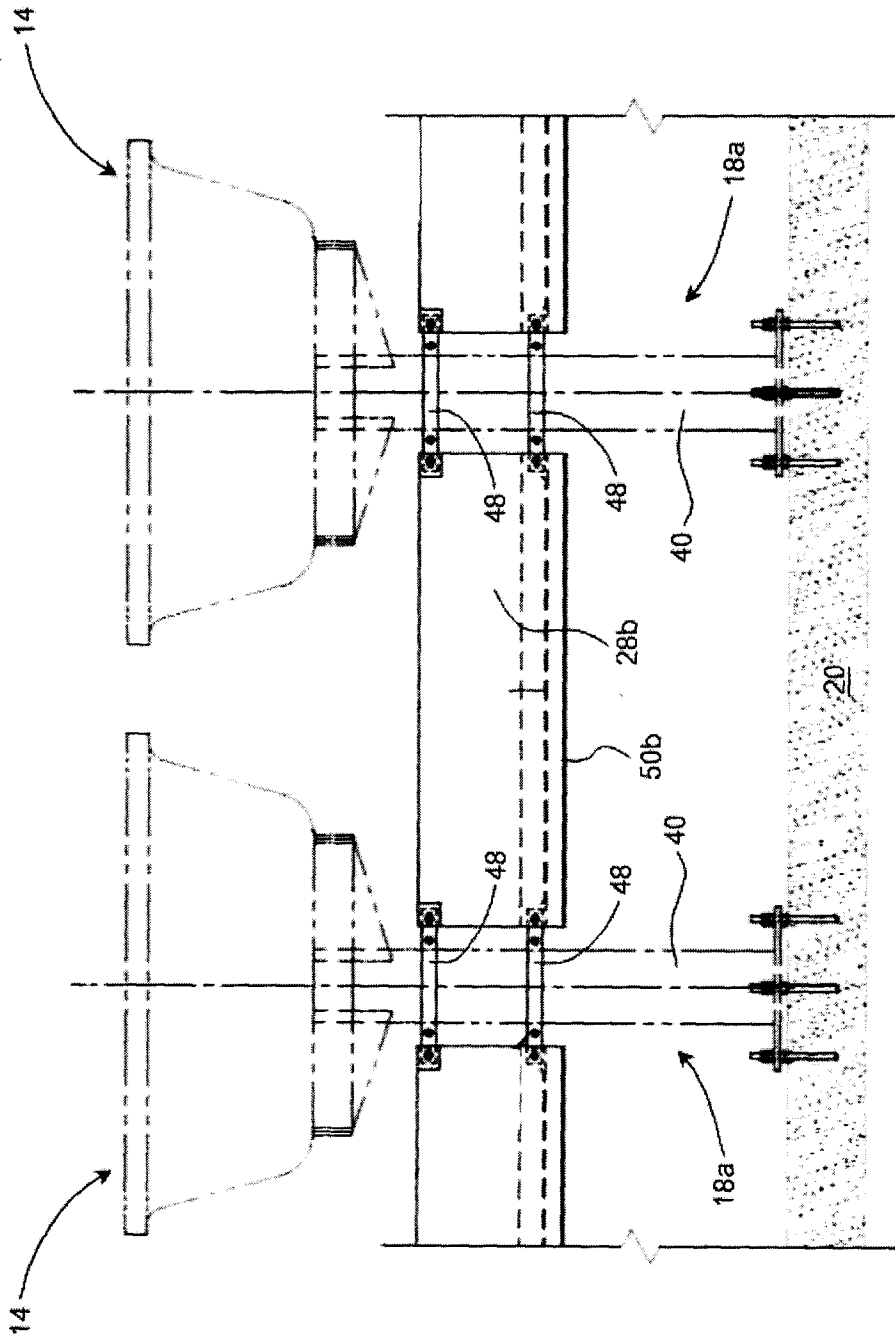

Figure 7

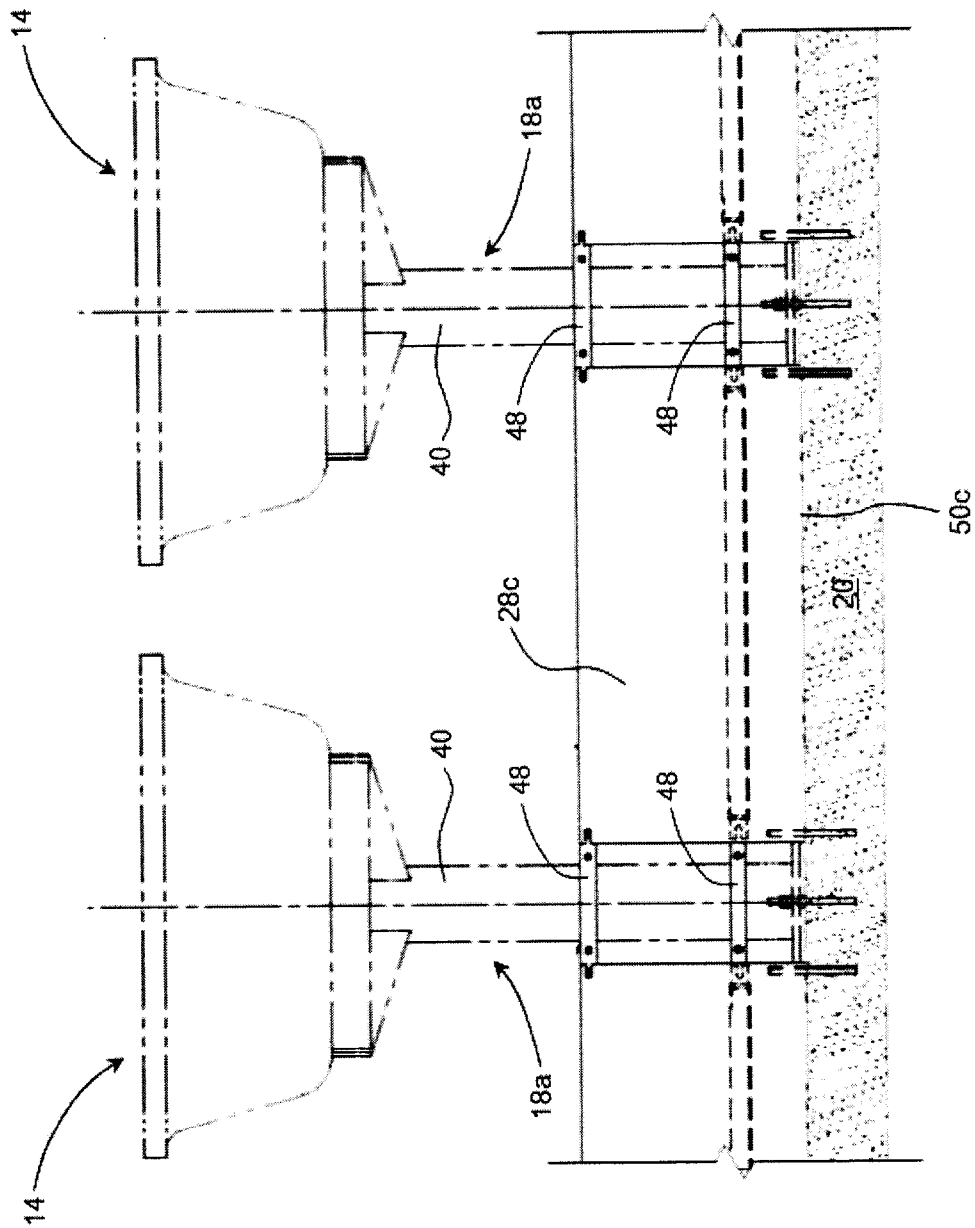

Figure 8

INTERNATIONAL SEARCH REPORT

International application No.
PCT/CA2012/001019

A. CLASSIFICATION OF SUBJECT MATTER
 IPC: **B22D 15/04** (2006.01) , **B22D 30/00** (2006.01)
 According to International Patent Classification (IPC) or to both national classification and IPC

B. FIELDS SEARCHED

Minimum documentation searched (classification system followed by classification symbols)
 IPC: **B22D 15/04** (2006.01) , **B22D 30/00** (2006.01)

Documentation searched other than minimum documentation to the extent that such documents are included in the fields searched

Electronic database(s) consulted during the international search (name of database(s) and, where practicable, search terms used)
 EPOQUE, TOTALPATENT, INTELLECT.

C. DOCUMENTS CONSIDERED TO BE RELEVANT

Category*	Citation of document, with indication, where appropriate, of the relevant passages	Relevant to claim No.
A	JP 61063351 A (Atoda Akira) 01 April 1986 (01-04-1986)	1-22
A	US 2007/0131380 A1 (Wobker et al.) 14 June 2007 (14-06-2007)	1-22
A	US 6,145,577 (Hunter et al.) 14 November 2000 (14-11-2000)	1-22
A	US 3,570,583 (Lauener) 16 March 1971 (16-03-1971)	1-22

Further documents are listed in the continuation of Box C. See patent family annex.

* Special categories of cited documents :	"T" later document published after the international filing date or priority date and not in conflict with the application but cited to understand the principle or theory underlying the invention
"A" document defining the general state of the art which is not considered to be of particular relevance	"X" document of particular relevance; the claimed invention cannot be considered novel or cannot be considered to involve an inventive step when the document is taken alone
"E" earlier application or patent but published on or after the international filing date	"Y" document of particular relevance; the claimed invention cannot be considered to involve an inventive step when the document is combined with one or more other such documents, such combination being obvious to a person skilled in the art
"L" document which may throw doubts on priority claim(s) or which is cited to establish the publication date of another citation or other special reason (as specified)	"&" document member of the same patent family
"O" document referring to an oral disclosure, use, exhibition or other means	
"P" document published prior to the international filing date but later than the priority date claimed	

Date of the actual completion of the international search 10 January 2013 (10.01.2013)	Date of mailing of the international search report 18 January 2013 (18-01-2013)
---	--

Name and mailing address of the ISA/CA Canadian Intellectual Property Office Place du Portage I, C114 - 1st Floor, Box PCT 50 Victoria Street Gatineau, Quebec K1A 0C9 Facsimile No.: 001-819-953-2476	Authorized officer Laurent de Camprieu (819) 994-0249
---	--

Box No. II Observations where certain claims were found unsearchable (Continuation of item 2 of the first sheet)

This international search report has not been established in respect of certain claims under Article 17(2)(a) for the following reasons :

1. Claim Nos. :
because they relate to subject matter not required to be searched by this Authority, namely :

2. Claim Nos. :
because they relate to parts of the international application that do not comply with the prescribed requirements to such an extent that no meaningful international search can be carried out, specifically :

3. Claim Nos. : 23
because they are dependent claims and are not drafted in accordance with the second and third sentences of Rule 6.4(a).

Box No. III Observations where unity of invention is lacking (Continuation of item 3 of first sheet)

This International Searching Authority found multiple inventions in this international application, as follows :

1. As all required additional search fees were timely paid by the applicant, this international search report covers all searchable claims.
2. As all searchable claims could be searched without effort justifying additional fees, this Authority did not invite payment of additional fees.
3. As only some of the required additional search fees were timely paid by the applicant, this international search report covers only those claims for which fees were paid, specifically claim Nos. :
4. No required additional search fees were timely paid by the applicant. Consequently, this international search report is restricted to the invention first mentioned in the claims; it is covered by claim Nos. :

- Remark on Protest** The additional search fees were accompanied by the applicant's protest and, where applicable, the payment of a protest fee.
- The additional search fees were accompanied by the applicant's protest but the applicable protest fee was not paid within the time limit specified in the invitation.
- No protest accompanied the payment of additional search fees.

INTERNATIONAL SEARCH REPORT
Information on patent family members

International application No.
PCT/CA2012/001019

Patent Document Cited in Search Report	Publication Date	Patent Family Member(s)	Publication Date
JP61063351A	01 April 1986 (01-04-1986)	None	
US2007131380A1	14 June 2007 (14-06-2007)	AT542620T BRPI0605210A CA2570957A1 CA2570957C CN101007339A CN101007339B DE102005059712A1 EP1795281A2 EP1795281A3 EP1795281B1 ES2381388T3 JP2007160402A JP4722821B2 KR20070062411A RU2404014C2 US7658221B2	15 February 2012 (15-02-2012) 09 October 2007 (09-10-2007) 12 June 2007 (12-06-2007) 23 August 2011 (23-08-2011) 01 August 2007 (01-08-2007) 26 January 2011 (26-01-2011) 21 June 2007 (21-06-2007) 13 June 2007 (13-06-2007) 09 July 2008 (09-07-2008) 25 January 2012 (25-01-2012) 25 May 2012 (25-05-2012) 28 June 2007 (28-06-2007) 13 July 2011 (13-07-2011) 15 June 2007 (15-06-2007) 20 November 2010 (20-11-2010) 09 February 2010 (09-02-2010)
US6145577A	14 November 2000 (14-11-2000)	BR9701272A BR9904303A CA2473671A1 CA2473671C CA2626322A1 CA2626322C CN1188029A CN1082859C CN1250697A CN1104295C MXPA04007172A US5901774A US5927374A US5971059A US2002060060A1 US6571860B2 US2003178170A1 US6779586B2 WO03061876A1	10 November 1998 (10-11-1998) 03 October 2000 (03-10-2000) 31 July 2003 (31-07-2003) 17 June 2008 (17-06-2008) 31 July 2003 (31-07-2003) 16 June 2009 (16-06-2009) 22 July 1998 (22-07-1998) 17 April 2002 (17-04-2002) 19 April 2000 (19-04-2000) 02 April 2003 (02-04-2003) 16 May 2005 (16-05-2005) 11 May 1999 (11-05-1999) 27 July 1999 (27-07-1999) 26 October 1999 (26-10-1999) 23 May 2002 (23-05-2002) 03 June 2003 (03-06-2003) 25 September 2003 (25-09-2003) 24 August 2004 (24-08-2004) 31 July 2003 (31-07-2003)
US3570583A	16 March 1971 (16-03-1971)	AT285847B BE718795A CH456056A DE1758933A1 DE1758933B2 ES357582A1 FR1582916A GB1186466A IS1752A7 IS991B6 JP48015775B NL6812517A NL154131B NO122093B NO125574B SE328096B	10 November 1970 (10-11-1970) 31 December 1968 (31-12-1968) 15 May 1968 (15-05-1968) 04 March 1971 (04-03-1971) 01 February 1973 (01-02-1973) 16 March 1970 (16-03-1970) 10 October 1969 (10-10-1969) 02 April 1970 (02-04-1970) 09 October 1968 (09-10-1968) 15 June 1978 (15-06-1978) 17 May 1973 (17-05-1973) 11 March 1969 (11-03-1969) 15 August 1977 (15-08-1977) 18 May 1971 (18-05-1971) 02 October 1972 (02-10-1972) 07 September 1970 (07-09-1970)