



(22) Date de dépôt/Filing Date: 1998/09/16

(41) Mise à la disp. pub./Open to Public Insp.: 1999/06/16

(45) Date de délivrance/Issue Date: 2003/10/21

(30) Priorité/Priority: 1998/06/11 (2,240,369) CA

(51) Cl.Int.<sup>6</sup>/Int.Cl.<sup>6</sup> B65D 19/20

(72) Inventeur/Inventor:  
QUIRION, YVAN, CA

(73) Propriétaire/Owner:  
QUIRION, YVAN, CA

(74) Agent: THERIAULT, MARIO D., P.ENG.

(54) Titre : CONTENEUR PLIABLE MONTE SUR PALETTE

(54) Title: FOLDABLE PALLET-MOUNTED CONTAINER

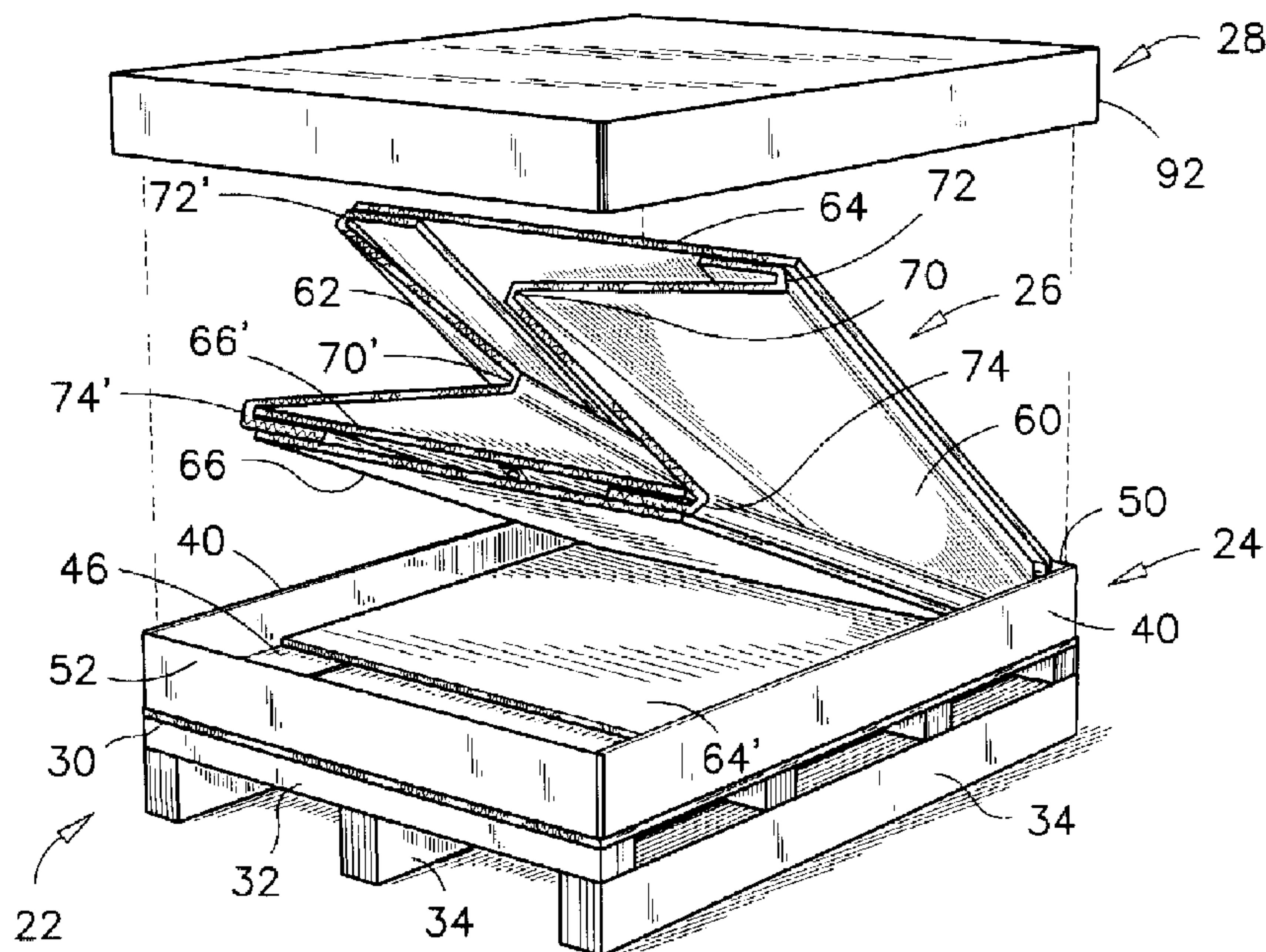

(57) Abrégé/Abstract:

A foldable pallet-mounted container comprising a shallow base mounted on a pallet, a foldable box mounted inside the shallow base, and a flanged cover having overall dimensions to fit over the shallow base for covering the shallow base when the foldable box is folded inside the shallow base, and for covering the foldable box when the foldable box is deployed. The shallow base is made of corrugated board and comprises a horizontal planar member and single-pleated uprising side members connected along a pair of opposite edges of the planar member. Each uprising side member has a reinforcing flap member connected thereto and overlapping the horizontal planar member. The foldable box is also made of corrugated board, and comprises first and second opposite side panels and first and second opposite end panels and a liner member connected to the horizontal planar member of the shallow base and to the first end panel. The foldable box is movable from a stowed mode to a deployed mode about a crease formed at the intersection of the liner member and the first end panel.

**TITLE: FOLDABLE PALLET-MOUNTED CONTAINER****ABSTRACT OF THE DISCLOSURE**

A foldable pallet-mounted container comprising a shallow base mounted on a pallet, a foldable box mounted inside the shallow base, and a flanged cover having overall dimensions to fit over the shallow base for covering the shallow base when the foldable box is folded inside the shallow base, and for covering the foldable box when the foldable box is deployed. The shallow base is made of corrugated board and comprises a horizontal planar member and single-pleated uprising side members connected along a pair of opposite edges of the planar member. Each uprising side member has a reinforcing flap member connected thereto and overlapping the horizontal planar member. The foldable box is also made of corrugated board, and comprises first and second opposite side panels and first and second opposite end panels and a liner member connected to the horizontal planar member of the shallow base and to the first end panel. The foldable box is movable from a stowed mode to a deployed mode about a crease formed at the intersection of the liner member and the first end panel.

**TITLE: FOLDABLE PALLET-MOUNTED CONTAINER****FIELD OF THE INVENTION**

This invention pertains to foldable pallet-mounted containers and more particularly, the present invention pertains to foldable pallet-mounted paperboard boxes that have shallow bases for reinforcing the lower perimeter thereof during use and for protecting the folded boxes during shipment and storage.

**BACKGROUND OF THE INVENTION**

Foldable pallet-mounted containers are used for shipping a variety of goods such as bulk material in aggregate, fibrous or powdery form, food in bags or pouches, commodities packed in small boxes and loose components used in assembly lines. Paperboard pallets and containers are generally preferred by the environment-conscious users, because this material is entirely recyclable. Corrugated paperboard material, however, is not as durable as wood, composite materials or metal, and the design of a container made with it requires additional ingenuity to ensure that the useful life of the container will be comparable or superior to the duration of those made with the conventional materials.

A first example of a foldable pallet-mounted container of the prior art is illustrated and described in US Patent 4,383,609 issued on May 17, 1983 to Eugene C. Lochmiller. The container of this invention comprises a corrugated cardboard base which is built into a wooden pallet, and a rectangular corrugated cardboard sleeve which is adapted to slide over the

base and to vertically interlock with the base. A cover member fits over the rectangular sleeve to form with the sleeve and the base, a closed container integrally mounted to a wooden pallet.

In a second example of a foldable container of the prior art, US Patent 4,927,026 issued on May 22, 1990 to Haas K. Gossler and Charles P. Roberts, discloses a corrugated cardboard box affixed to a wooden pallet. The box is made of two parts. The first part comprises a floor and four vertically extending flaps. The second part is a rectangular tubular member that fits over the four flaps, thereby forming a double layered container.

Another type of collapsible corrugated board container is described in US Patent 5,318,219 issued on June 7, 1994 to Glenn M. Smith. In this invention, an integral corrugated cardboard box is stapled to a pallet and is foldable in a compact flat form. The bottom portion of the box is foldable over itself to allow opposite sides of the box to lay parallel over top of one another.

A further example of a foldable container is described in US Patent 5,441,154 issued on August 15, 1995 to Donald R. Youell, III. The paperboard container and pallet system described therein comprises a shallow deck portion mounted on hollow cardboard runners, a wall-forming portion and a cover. The wall-forming portion has locking tabs on its lower edge, and these tabs are adapted to lock into matching slots through the deck portion and the hollow runners. Notches are provided in the hollow runners for selectively releasing the locking tabs from the deck portion and refolding the wall-forming portion of the container into the deck portion.

It is believed that a first preferred requirement by the industry regarding foldable pallet-mounted containers is that the wall forming portion should be an integral part of the base portion such that the box portion is inseparable from the base portion throughout the life of the container. A second preferred requirement by the industry is believed to be that the container should be foldable without having to manipulate the pallet, or otherwise reach under the pallet and into intricate cavities to undo locking tabs. Similarly, it is believed that a third preferred requirement by the industry is that the deployed container has sufficient strength for resisting lateral internal pressure associated with a loading thereof with heavy granular material for example. Finally, another preferred requirement by the industry is believed to be that the corrugated board container is securely foldable to avoid damages during transport back to the original filler.

The foldable containers of the prior art are believed to be deficient at least one of the above preferred requirements, and it is this reason basically that has contributed to the development of a market demand for better foldable containers capable of resisting the loading of a variety of products and in particular, that can be used for a relatively large number of shipping-returning cycles.

## **SUMMARY OF THE INVENTION**

In the present invention, however, there is provided a foldable pallet-mounted container that is easy to deploy and to fold down without instructions, that has stiffening members to provide strength against lateral internal loading caused by granular or similar loose loads, and that is sturdy enough to resist the stresses of several ship and return cycles.

In accordance with a first aspect of the present invention, there is provided a foldable pallet-mounted container comprising a shallow base mounted on a pallet, a foldable box mounted inside the shallow base, and a flanged cover having overall dimensions to fit over the shallow base, for covering the shallow base when the foldable box is folded inside the shallow base, and for covering the foldable box when the foldable box is deployed.

The shallow base is made of corrugated board material and comprises a horizontal planar member having four straight edges defining four right angle corners. The shallow base also comprises a pair of single-pleated uprising side members connected to and along a pair of opposite edges of the planar member. Each uprising side member has a reinforcing flap member connected thereto and overlapping the horizontal planar member. The foldable box is also made of corrugated board material, and comprises first and second side panels and first and second end panels and a first liner member connected to the horizontal planar member of the shallow base and to the first end panel. The pallet is made of a plurality of runners and a plurality of rails affixed to the runners in a perpendicular relation therewith, the runners and rails are made of laminated strips of corrugated board.

A primary advantage of the above-described structure is that when the foldable box is deployed, the side and end panels of the box are retainable between the uprising side members of the shallow base and inside the flanged cover for resisting horizontal shear stresses producible by a content of the foldable box.

Another advantage of this structure is that when the foldable box is folded inside the shallow base and cover, the foldable box is protectable against the shearing, tearing and crushing stresses normally associated with the handling and storing of foldable containers, especially when the foldable containers are handled or piled in stacks.

In accordance with another aspect of the present invention, there is provided a foldable container comprising a shallow base made of corrugated board and having a horizontal planar member having four straight edges defining four right angle corners. The shallow base also has first and second pairs of single-pleated uprising side members connected to and along corresponding pairs of opposite straight edges of the horizontal planar member, and a template member laid over the horizontal planar member and defining with three of the uprising side members a recess bordering the horizontal planar member. The foldable container of this aspect of the present invention also comprises a foldable box mounted inside the shallow base. The foldable box is also made of corrugated board. The foldable box has first and second side panels and first and second end panels and a first liner member connected to the horizontal planar member of the shallow base and to the first end panel. Each of the first and second side panels and second end panel has a lower edge and a nominal thickness, this nominal thickness is less than a width of the recess such that when the foldable box is deployed, the lower edges of the foldable box are securable in the recess for retaining the foldable box in a deployed mode.

The foldable container of the present invention is easily operable from a folded mode to a deployed mode by a user standing beside the container, without having to reach under or otherwise manipulate the base

of the container. The operation of the container of the present invention is understandable in a glance and written instruction to a first user are normally not required.

5 In accordance with yet another aspect of the present invention, the foldable container and the foldable pallet-mounted container of the present invention are entirely made of corrugated board material joined with adhesive. These constructions do not contain staple or other metal or plastic fastener. The adhesive used in the manufacture of the foldable  
10 containers and pallets is a water-based pulpal glue. Therefore, the foldable containers and pallets of the present invention are entirely recyclable after their useful life.

The foldable pallet-mounted container and the foldable container of the present invention are further more durable than the foldable pallet-boxes of the prior art. Experience has shown that some of the pallet-boxes  
15 of the prior art are usable only for 1-2 ship-return cycles, wherein the foldable pallet-mounted containers of the preferred embodiments have averaged in many instances, up to 6-7 ship-return cycles before being replaced.

#### **BRIEF DESCRIPTION OF THE DRAWINGS**

20 Other advantages of the invention will be apparent from the following description of the preferred embodiments illustrated in the accompanying drawings, in which:



- **FIG. 1** is a perspective view of the foldable pallet-mounted container of the first preferred embodiment showing the container in a partly folded position and the cover thereof in an exploded view mode above the container;
- 5 - **FIG. 2** is a perspective view of the foldable pallet-mounted container of the first preferred embodiment showing the container in a fully deployed and usable mode;
- **FIG. 3** is a longitudinal cross-section view through the foldable pallet-mounted container of the first preferred embodiment showing  
10 the foldable box in a collapsed mode inside the shallow base;
- **FIG. 4** is also a longitudinal cross-section view through the foldable pallet-mounted container of the first preferred embodiment, as seen from a same location as in **FIG. 3**, but with the foldable box in a fully deployed mode and the flanged cover installed thereon, such  
15 as would be seen along line 4-4 in **FIG. 2**;
- **FIG. 5** is a plan view of the foldable pallet-mounted container of the first preferred embodiment without the cover;
- **FIG. 6** is a transversal cross-section view through the foldable pallet-mounted container of the first preferred embodiment in a fully  
20 deployed mode, as seen along line 6-6 in **FIG. 2**;
- **FIG. 7** is an enlarged view of a typical overlapping of a side panel of the foldable box over an end panel, as seen in detail circle 7 in **FIG. 5**;

- **FIG. 8** is an enlarged cross-section view of the forming of the shallow base of the foldable pallet-mounted container of the first preferred embodiment as seen in detail circle 8 in **FIG. 6**;
- 5 - **FIG. 9** is an enlarged plan view of the typical double-crease fold formed in a side panel of the container of the first preferred embodiment as seen in detail circle 9 in **FIG. 5**;
- **FIG. 10** is a flat pattern of the shallow base of the foldable pallet-mounted container of the first preferred embodiment;
- 10 - **FIG. 11** is a perspective view of the foldable pallet-mounted container of the second preferred embodiment without a flanged cover;
- **FIG. 12** is a plan view of the foldable pallet-mounted container of the second preferred embodiment;
- 15 - **FIG. 13** is a cross-section view through the foldable pallet-mounted container of the second preferred embodiment as seen along line 13-13 in **FIG. 12**;
- **FIG. 14** is a flat pattern of the shallow base of the foldable pallet-mounted container of the second preferred embodiment;
- 20 - **FIG. 15** is a perspective view of the foldable pallet-mounted container of the second preferred embodiment showing the foldable box being pulled out of the shallow base, thereby illustrating a first step in opening the container;

- **FIG. 16** is a perspective view of the foldable pallet-mounted container of the second preferred embodiment showing the folded wall-forming portion being extended into an open position, thereby illustrating a second step in opening the container;
- 5 - **FIG. 17** is a perspective view of the foldable pallet-mounted container of the second preferred embodiment showing the foldable box is a fully deployed mode;
- **FIG. 18** is a perspective view of the foldable pallet-mounted container of the second preferred embodiment in a fully deployed mode with a flanged cover mounted thereon;
- 10 - **FIG. 19** is a perspective view of the foldable pallet-mounted container of the second preferred embodiment with one end of the foldable box being lifted up, thereby illustrating a first step in folding the container;
- 15 - **FIG. 20** is a perspective view of the foldable pallet-mounted container of the second preferred embodiment with the foldable box in a collapsed mode prior to folding it down into the shallow base, thereby illustrating a second step in folding the container;
- **FIG. 21** is a perspective view of the pallet used with the foldable pallet-mounted container of the first preferred embodiment;
- 20 - **FIG. 21A** is an enlarged view of the interlocking of a rail and a runner in the pallet illustrated in **FIG. 21**, as shown in detail circle **21A** in **FIG. 21**.

**DETAILED DESCRIPTION OF THE PREFERRED EMBODIMENT**

The foldable pallet-mounted container **20** of the first preferred embodiment is illustrated in a partially folded mode in **FIG. 1**, and in a deployed mode in **FIG. 2**. The foldable pallet-mounted container **20** comprises broadly; a pallet **22**, a shallow base **24** mounted on the pallet **22**, a foldable box **26** mounted inside the shallow base **24**, and a flanged cover **28** for covering the shallow base **24** when the foldable box **26** is folded inside the shallow base, or for covering the upper side of the foldable box **26** when the foldable box is fully deployed.

The pallet **22** is made of a double-ply corrugated board top planar member **30**; a plurality of transversally extending laminated multi-ply corrugated board runners **32** equally spaced and glued to the underside of the top planar member **30**; and a plurality of laminated multi-ply corrugated board rails **34** glued perpendicularly to and under the runners **32**.

The runners **32** are preferably aligned perpendicularly to the corrugations in the top planar member **30**, and the corrugations in the runners **32** and rails **34** are preferably aligned vertically when the pallet is in use. The runners **32** are aligned along a transversal orientation of the foldable pallet-mounted container **20** of the first preferred embodiment, and the rails **34** are aligned along a longitudinal orientation thereof. The runners **32** and rails **34** each preferably comprises about eighteen to twenty (18-20) plies of corrugated board.

The shallow base **24** of the foldable pallet-mounted container **20** of the first preferred embodiment is made of single-ply corrugated board and is glued to the top planar member **30** of the pallet **22**. The single-ply board

of the shallow base **24** is folded to form a shallow receptacle having the sides extending at a height 'A' of about 4-3/4 inches (12 cm) above the top planar member **30**.

The corrugations in the shallow base **24** are aligned transversally relative to the foldable container **20**, as indicated by label 'B' in FIG. 10. The uprising side members **40** of the shallow base **24** as illustrated in FIGS. 8 and 10, are folded along bend lines **42** to form a single pleat **44** having a reinforcing flap member **46** overlapping and being glued to the bottom surface **48** of the shallow base **24**. The width 'C' of the reinforcing flap member **46** is preferably about 4-3/4 inches (12 cm). The uprising end members **50,52** of the shallow base **24** are made of a single-ply planar member and are bent along bend lines **54** as illustrated in FIG. 10. The end members **50,52** each has at each end thereof, a tab **56** the length of which extends the full flat width of the single-pleated uprising side member **40** and the width of the flap member **46**. Upon forming the shallow base **24**, each tab **56** is tucked inside the pleat **44** in a respective end of an uprising side member **40** for reinforcing each corner of the shallow base **24**.

The structure of the flanged cover **28** is identical to the structure of the shallow base **24** except that the inside dimensions of the cover **28** are slightly larger than those of the base **24**, such that the flanged cover **28** fits over the shallow base **24** for covering the shallow base completely when the foldable pallet-mounted container **20** of the first preferred embodiment is in a collapsed form and is returned to a supplier for reuse for example. This feature prevents possible damage to the foldable container, which could occur during handling and transport of the folded container, especially when several containers are stacked on top of one another.

Referring back to **FIGS. 1** and **2**, the foldable box **26** of the pallet-mounted container of the first preferred embodiment is made of two side panels **60,62** and two end panels **64,66**. The side and end panels are made of a triple-ply corrugated board having a nominal thickness of about 0.5  
5 inch (12 mm) and wherein the corrugations are aligned vertically when the foldable box is deployed. The two side panels **60,62** each has three vertical folds **70,72,74** and **70',72',74'** in a central and end portions thereof respectively and are foldable inside the box as illustrated in **FIG. 1**. Each  
10 fold **70,72,74,70',72'** or **74'** in the side panels is preferably a double crease fold having a width '**D**' of about 1-1/4 inches (32 mm), as illustrated in **FIG. 9**. This feature is to prevent a deterioration of the folds when the foldable container of the first preferred embodiment is re-used many times.

With reference to **FIG. 4**, the first end panel **64**, hereinafter referred  
15 to as the outside end panel, has an outside liner portion **64'** extending therefrom and overlapping the inside horizontal surface **48** of the shallow base **24**, and is glued to the inside surface **48** of the base **24**. The second end panel **66**, hereinafter referred to as the inside end panel has an inside  
20 liner portion **66'** which is foldable inside the foldable box about a crease **80** along a lower edge of the foldable box, and toward and away from the inside end panel **66**.

Referring now particularly to **FIGS. 3** and **4**, a longitudinal cross-section view of the foldable box **26** of the first preferred embodiment is shown therein with the box **26** in a folded mode and in a fully deployed  
25 mode respectively. The foldable box **26** is set inside the shallow base **24** to fold and unfold along the longitudinal direction of the base **24** as illustrated in **FIG. 3**. In that respect, the inside length '**L**' of the shallow base **24** is longer than the height '**H**' of the foldable box, by at least a first

gap 'E', which is equivalent to the collapsed thickness of the foldable box 26. When the foldable box 26 is made of triple-ply corrugated board material as for the foldable box of the first preferred embodiment, the dimension of the first gap 'E' is between about 4-1/2 inches (11.4 cm) and about 5 inches (12.7 cm) and most preferably about 4-3/4 inches (12 cm).

The first gap 'E' allows for the unfolding of the foldable box 26 about a first transversal crease 76 across the outside end panel 64-64', in a direction represented by arrow 78 in FIG. 3. After the foldable box 26 has been folded upwardly about crease 76 over an angular distance of 90<sup>0</sup>, the inside end panel 66 is movable longitudinally relative to the outside end panel 64 in order to extend the side panels 60,62 and to deploy the foldable box 26 fully as illustrated in FIGS. 2 and 4.

The minimum dimension of a second gap 'F' in the shallow base 24 as shown in FIG. 3 is preferably about one inch (2.5 cm) to facilitate the insertion of one's fingers therein to grasp an upper edge of the foldable box 26, and to tilt the foldable box 26 up from the shallow base 24, as described above. It will be appreciated, however, that the width of this second gap 'F' can be wider than one inch (2.5 cm) to accommodate foldable oblong boxes that have a length 'L' dimension which is greater than their height 'H'.

Common dimensions for the foldable box 26 of the preferred embodiments and the corresponding dimensions for gap 'F' are as follows, when making reference to FIGS. 3-6.

<u>Product #</u>	<u>Length 'L'</u>	<u>Width 'W'</u>	<u>Height 'H'</u>	<u>Gap 'F'</u>
001	44.75 in. (114 cm)	32 in. (81 cm)	34 in. (86 cm)	6 in. (15 cm)
002	46.5 in. (118 cm)	46 in. (117 cm)	40 in. (102 cm)	1.5 in. (4 cm)

When the foldable box 26 is fully deployed as illustrated in **FIG. 4**, the inside liner portion 66' is foldable downward against the outside liner portion 64'. The folding down of the inside liner portion 66' about the second transversal crease 80, pushes of the folds 70,70' in the side panels outwardly and prevents the side panels 60,62 from folding back in. When the inside liner portion 66' is overlapping the outside liner portion 64', the foldable pallet-mounted container of the first preferred embodiment has a bottom portion comprising, over a major area thereof, nine plies of corrugated board. This characteristic of the container of the first preferred embodiment is particularly advantageous for providing relatively large bending strength in the base of the container when supporting heavy fragmented loads inside the container 20.

There is also provided a string or strapping 90 connected to the inside liner portion 66' of the end panel, and to the upper edge of the inside end panel 66. The strapping 90 is useful for lifting the inside liner portion 66' upwardly while standing near the inside end panel 66, and for allowing an easy folding of the foldable box 26. The lifting of the inside liner portion 66' and the folding of the box 26 is doable by one person initially standing near the inside end panel 66, by lifting the inside liner portion 66', by pushing the inside end panel 66 toward the outside end panel 64, and by folding the folded box 26 down against the bottom surface 48 of the shallow base 24, as will be described later when making reference to **FIGS. 15-20**.



The flanged cover 28 is then placed over the base 24 for protecting the shallow base 24 and the folded box 26 therein against damage during transport of the folded container 20 to the original filler of the container 20, or during handling and storage of the container 20.

5 Referring now to FIGS. 6 and 8, the deployed box 26 of the first preferred embodiment is particularly strong to resist transversal shear stresses therein, for being contained inside the pleats 44 and reinforcing flap members 46 of the shallow base 24, and inside the rim member 92 of the flanged cover 28.

10 When looking at FIGS. 4, 5 and 7, one will appreciate that the deployed box, and in particular the lower region thereof also has generous strength in a longitudinal direction, for having its end panels 64,66, connected to the inside and outside liner portions 64',66' which when the container is being used, are laid over top of one-another against the bottom  
15 surface 48 of the container and are covered, usually, by the material contained inside the container. Furthermore, the end panels 64,66 are connected to the side panels 60,62, by overlapping and gluing the side panels to the end panels as illustrated in FIGS. 5 and 7. The preferred overlapping distance 'G' is about 6 inches (15 cm) to ensure a strong bond  
20 between the sides and end panels and a good circumferential tensile strength of the foldable box 26 of the first preferred embodiment. The construction thus described is particularly advantageous for transporting material in bulk form or loose articles where horizontal shear strength in the container is required.

25 It will be appreciated that the configuration of the pallet 22 is not intended to constitute structural limitations to the present invention. The

foldable container **20** of the first preferred embodiment may be used without the pallet **22**, for mounting on a separate wooden pallet or plywood board for examples, or for mounting on a corrugated board pallet differing from the described pallet **22**. The foldable container of the first preferred  
5 embodiment may also be used without a pallet, as a stationary container or otherwise. Such alternate embodiments are considered to be within the scope of the present invention wherein all the above-described advantages are nonetheless obtained.

10 Referring now to **FIGS. 11-14**, there is illustrated therein a second preferred embodiment of the present invention. The dimensions of the foldable pallet-mounted container of the second preferred embodiment **100** are similar to those of product no. 002 shown on a previous page. The operation of the foldable pallet-mounted container of the second preferred  
15 embodiment **100** does not differ substantially from the foldable pallet-mounted container of the first preferred embodiment **20**. Slight variations in the structure of the second embodiment **100** are found in the pallet **120**, in the shallow base **130** and in the construction of both the inside and outside end panel members **140,150**.

20 The pallet **120** of the container of the second preferred embodiment is comprised of three runners **122** secured to the bottom surface of the shallow base **130**. Here again, the pallet **120** is optional and the container **100** is usable without it. Each runner **122** is made of a plurality of corrugated board layers stacked side by side and the corrugations in each  
25 layer are aligned vertically. Each runner **122** has a width of about 4 inches (10 cm) and a height of about 3 inches (8 cm). The floor-contacting surface of each runner is covered by a single strip **124** of corrugated board laid against the edges of the plurality of layers described above.

The shallow base **130** of the foldable pallet-mounted container **100** of the second preferred embodiment is made of a single ply corrugated board. The alignment of the corrugations in the paperboard sheet of the shallow base **130** as indicated by label 'J' in **FIG. 14** is transversal to the recommended placement of the runners as represented by labels **122'** in **FIG. 14**. This arrangement provides greater stiffness to the bottom surface of the base **130** when the container is lifted by a forklift truck for example.

Referring particularly to **FIGS. 13** and **14**, the side members **152,154** of the shallow base **130** are folded over to form a double-ply arrangement defining a cavity **160** which has a same function as the pleat **44** as previously described, that is to receive and retain a tab **156** in each corner of the base **130** for interlocking the corners of the shallow base. The inside edge of each side member **152,154**, has a series of tabs **157** thereon which are spaced apart and sized to be inserted into corresponding slots **158**, in the bottom surface **162** of the shallow base for retaining the side members **152,154** in a folded mode as illustrated in **FIG. 13**.

The outside end member **140** of the foldable container of the second preferred embodiment is made of two layers **164,174** or **166,176** of corrugated board each having three plies. The outside end panel member **164** has an outside liner portion **164'** extending over the bottom surface **162** of the base and is glued to the base **130**, in a same way as the container of the first preferred embodiment **20**. On top of the outside liner portion **164'**, there is provided an additional layer **168** of triple-ply corrugated board glued to the outside liner portion **164'**, hereinafter referred to as the template member **168**. The overall dimensions of the template member **168** are smaller than the inside dimensions of the shallow base **130**, such that there is a gap 'K' of at least about one inch (2.5 cm) defined between the

edges of the template member 168 and the sides 152,154 of the shallow base 130. When the foldable box portion 170 of the container of the second preferred embodiment is deployed, the lower edges of the foldable box portion 170 are inserted in the gap 'K' to retain the folds 172,172' of the box in a straight alignment and to retain the foldable box 170 in an opened configuration.

The foldable box portion 170 is made of two foldable panels 174,176 made of triple-ply corrugated board that are joined at vertical joints 178,180 on a respective end panel 140,150. The foldable panels 174,176 overlap the outside end panel member 164 and the inside end panel member 166 entirely. Both vertical joints 178,180 are diametrically opposite relative to the perimeter of the foldable box 170, such that both foldable panels 174,176 are symmetrical, easy to manufacture and easy to assemble.

Referring now to FIGS. 15-20, there is illustrated therein a preferred method for deploying and folding the foldable pallet-mounted container of the second preferred embodiment. It will be appreciated that this method also applies to a great extent, to the foldable pallet-mounted container of the first preferred embodiment.

Starting with FIG. 15, the foldable box 170 is tilted upwardly from the shallow base 130, about the lower edge of the outside end panel 140, in a direction represented by arrow 184. The angle of tilting the container is substantially a right angle, or slightly more, one or two degrees for example, to allow the inside end panel 150 to slide over the template member 168 covering the bottom surface of the shallow base 130. The inside end panel 150 is then pulled away from the outside end panel 140 in

a direction indicated by arrow 186, to cause the folds 172,172' to stretch and align straight. When the box 170 is fully stretched, the lower edges of the box drop into the gap 'K' around template member 168, such that the box remains in an opened configuration as shown in FIG. 17. A flanged cover 188 is then placed over the open side of the box to protect the content  
5 of the foldable box 170.

The folding of the container prior to storing it or sending it back to the original filler for example is initiated by slightly lifting the foldable box 170 and tilting it about the lower edge of the outside end panel 140 as indicated by arrow 190 in FIG. 19, and pushing the inside end panel 150  
10 against the outside end panel 140, as indicated by arrow 192. When the inside end panel 150 is folded against the outside end panel 140, the folded box 170 may then be tilted down into the shallow base 130 in a direction as indicated by arrow 194 in FIG. 20, with the inside end panel 150 laying  
15 against the template member 168. The folded box 170 and shallow base 130 are then preferably covered with the flanged cover 188 for protecting the folded box 170 during shipment and storage, especially when two or more foldable containers are stacked over one-another. The methods described above for deploying or folding the container of the second  
20 preferred embodiment are easily effected by one person while standing near the foldable container. This person does not have to reach under the base 130 or otherwise manipulate the pallet 120.

The method described above does not require detailed instruction or much training to teach a new user how to deploy one of the containers of the preferred embodiments. The resiliency of the folds 172,172' forces the  
25 folded box 170 to open as soon as the folded box reaches an upward position. A further pulling on the extendible end 150 of the box causes the

lower edge of the box to fall into the gap 'K' around the template member 168, thereby keeping the box from folding back. For the foldable container of the first preferred embodiment, the pulling on the extendible end 66 of the box causes the inside liner portion 66' to fall down, thereby preventing the box from folding back in. Once a person has deployed one of the foldable containers of the preferred embodiments, it is relatively easy for that person without having recourse to written instruction, to reverse the above procedure and to fold the container back into a collapsed mode.

Referring now to **FIGS. 21 and 21A** the pallet 22 mounted under the foldable pallet-mounted container of the first preferred embodiment is illustrated therein in order to describe an important structural characteristic thereof. As it was mentioned earlier, this pallet 22 as well as the foldable containers of the first and second preferred embodiments are manufactured with a water-based pulpal glue. The preferred glue is a type known in the industry under the tradename of SWIFT 47206 <sub>TM</sub> manufactured by or for Reichhold Chemicals, Inc. of P.O. Box 13582, Research Triangle Park, North Carolina, 27709, U.S.A. The glueing process is a cold process wherein the glue is applied and the curing is done at ambient temperature.

The gluing of the runners 32 to the rails 34 is done under sufficient pressure to interlock the runners 32 and the rails 34 together. Sufficient pressure means a pressure that can cause a deformation 'M' in the runners 32 and a deformation 'N' in the rails 34 of about 1/8 inch (3 mm) in each surface, such that the interlocking engagement is a stress-related, mutually-induced double deformations having a total depth of at least about 1/4 inch (6 mm). This type of interlocking engagement has been found to be advantageous for providing superior shear and bending strength in the pallet of the preferred embodiment, as compared to conventional

corrugated board pallets. As an example, conventional corrugated board pallets have a typical loading capacity of about 500 lbs. (227 kg) in racking mode, that is supported on both outside rails only. The pallet of the preferred embodiment 22 with the described interlocking engagement and the specified adhesive has a capacity in racking mode of 2200 lbs. (1000 kg). This feature is also appreciable for providing a pallet 22 with greater lateral or diagonal compression strength, better resistance to shocks and rough handling and a longer useable life as compared to the conventional corrugated board pallets.

While the preferred embodiments of this invention were described as being made of corrugated board, other materials are also contemplated by the inventor of the present invention, and are considered to be within the scope of this invention. For examples, it is believed that the foldable containers and pallets of the present invention and similar structures embodying the innovative features described herein can be manufactured with materials such as paperboard, cardboard, fiberboard, wood board, plastic sheet, plastic moulding, fiberglass, plywood, pressed wood, sheet metal, fabric or similar flexible material mounted over a rigid frame or similar materials or similar composite structures. It will also be appreciated that various modifications, alternate construction and equivalents may also be employed without departing from the true spirit and scope of the invention. Therefore, the above description and accompanying illustrations should not be construed as limiting the scope of the invention which is defined by the appended claims.

## CLAIMS

I claim:

1. A foldable container comprising:
    - a shallow base having a horizontal planar member having four straight edges defining four right angle corners, single-pleated uprising side members respectively connected to and along one of opposite said edges, and reinforcing flap members, each being connected to one of said uprising side members and overlapping said horizontal planar member;
    - a foldable box mounted inside said shallow base; said foldable box having first and second opposite side panels and first and second opposite end panels and a first liner member connected to said horizontal planar member of said shallow base and to said first end panel; said foldable box being foldable into and out said shallow base, about a connection between said first liner member and said first end panel; and
    - a flanged cover for covering said shallow base when said foldable box is folded inside said shallow base, and for covering said foldable box when said foldable box is deployed;
- such that when said foldable box is deployed, said side panels are retainable between said uprising side members of said shallow base and inside said flanged cover for resisting horizontal shear stresses producible by a content of said foldable box.



2. The foldable container as claimed in **claim 1**, wherein said first liner member is affixed to said horizontal planar member.
3. The foldable container as claimed in **claim 1**, wherein said connection comprises a first horizontal crease in said first end panel.
4. The foldable container as claimed in **claim 1** wherein said flap members are affixed to the horizontal planar member.
5. The foldable container as claimed in **claim 4**, wherein a width of each said flap members is about 4-3/4 inches (12 cm).
6. The foldable container as claimed in **claim 5**, wherein said flanged cover has a rim member for enclosing said shallow base.
7. The foldable container as claimed in **claim 1**, wherein each said first and second side panels has three vertical folds therein and is foldable inside said foldable box about said vertical folds.
8. The foldable container as claimed in **claim 7**, wherein each said vertical folds is a double crease fold having a width of about 1-1/4 inches (32 mm).
9. The foldable container as claimed in **claim 5**, wherein a height of each said uprising side members is about 4-3/4 inches (12 cm).

10. The foldable container as claimed in **claim 7**, wherein said second end panel has a second liner member connected thereto along a second horizontal crease, and said second liner member is foldable inside said foldable box about said second horizontal crease, toward and away from said second end member for acting against said vertical folds and retaining said foldable box in an open mode.
11. The foldable container as claimed in **claim 1**, further comprising a pallet mounted under said shallow base.
12. The foldable container as claimed in **claim 11**, wherein said shallow base is made of corrugated board material and said pallet is made of a plurality of runners fabricated with laminated corrugated board strips, and glued to an underside of said horizontal planar member.
13. The foldable container as claimed in **claim 12**, wherein said runners are oriented transversally to the corrugations in said horizontal planar member.
14. The foldable container as claimed in **claim 10**, wherein said first and second side panels, first and second end panels, first and second liner members are made of triple-ply corrugated board material.
15. The foldable container as claimed in **claim 13**, wherein said horizontal planar member of said shallow base comprises three plies of corrugated board.

16. A foldable container, comprising:  
a shallow base having a horizontal planar member having four straight edges defining four right angle corners, single-pleated uprising side members respectively connected to and along one of said straight edges, and a template member laid over said horizontal planar member and defining with some of said uprising side members a recess bordering said horizontal planar member; and  
a foldable box mounted inside said shallow base; said foldable box having first and second opposite side panels and first and second opposite end panels and a first liner member connected to said horizontal planar member of said shallow base and to said first end panel; said foldable box being foldable into and out said shallow base, about a connection between said first liner member and said first end panel; each said first and second side panels and said first end panel having a lower edge and a thickness, and said thickness being less than a width of said recess:  
such that when said foldable box is deployed, said lower edges are securable in said recess for retaining said foldable box in a deployed mode.
17. The foldable container as claimed in **claim 16**, further comprising a flanged cover for enclosing an open side of said foldable box when said foldable box is deployed, and for covering said shallow base when said foldable box is folded inside said shallow base.
18. The foldable container as claimed in **claim 17**, further comprising a plurality of runners affixed to an underside of said shallow base.

- 19.** The foldable pallet-mounted container as claimed in **claim 16**, wherein said shallow base and said foldable box are made of corrugated board material, and an adhesive used in the manufacture thereof is a water-based pulpal glue.
- 20.** A pallet comprising;  
a top planar member having an upper surface and a lower surface;  
a plurality of spaced-apart runners each having an upper side and a lower side, and said upper side being affixed to said lower surface of said top planar member;  
a plurality of spaced apart rails affixed to said lower sides of said runners in a substantially perpendicular orientation relative to said runners;  
a plurality of interlocking connections between said rails and said runners, each said interlocking connections comprising a first deformation in one of said runners and a second deformation in one of said rails, glued together; each said deformations being a pressure-induced surface deformation of 1/8 inch deep.

Mario D. Theriault, P.Eng.  
“Patent Agent for Applicant”



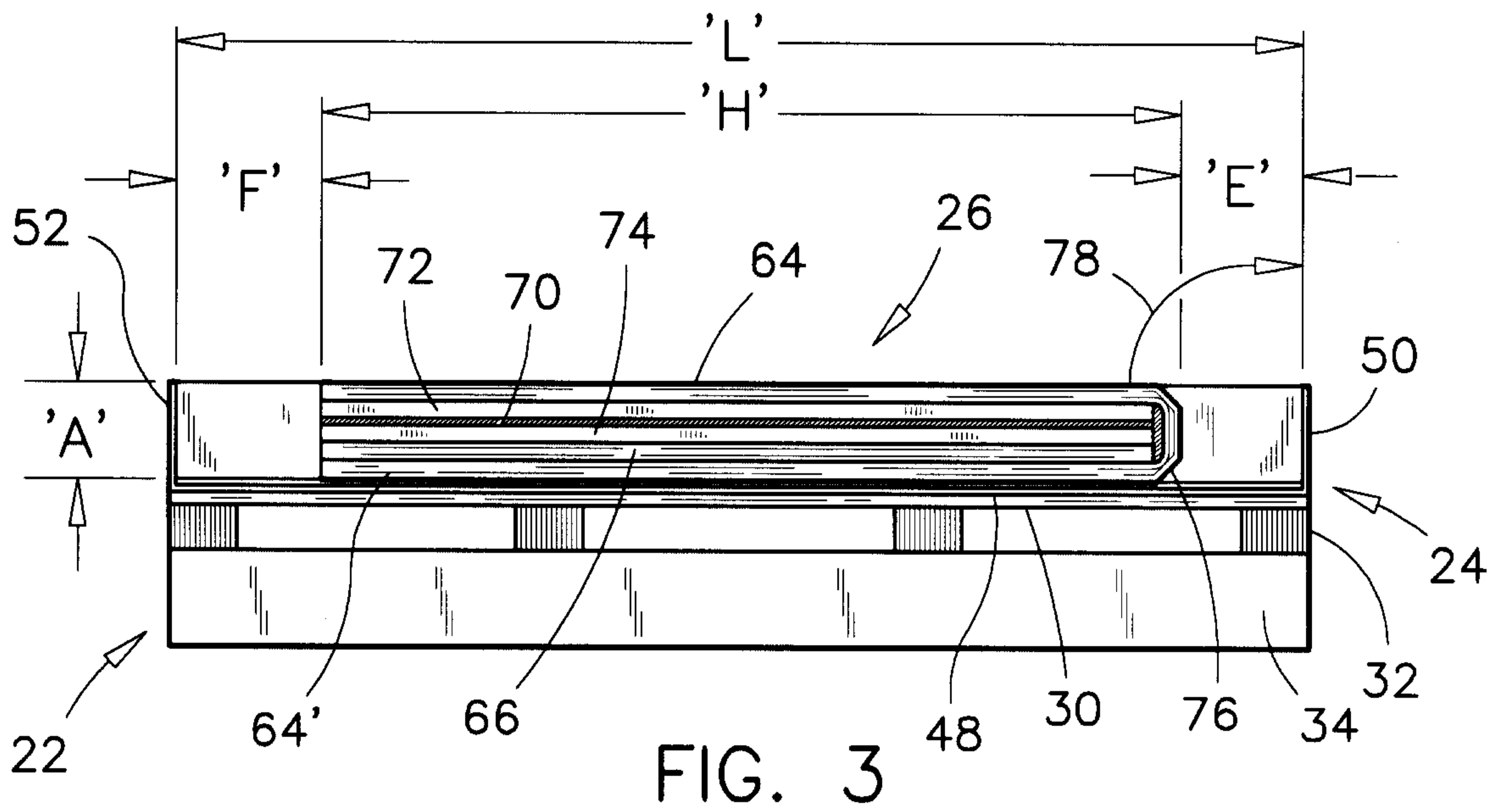

FIG. 3

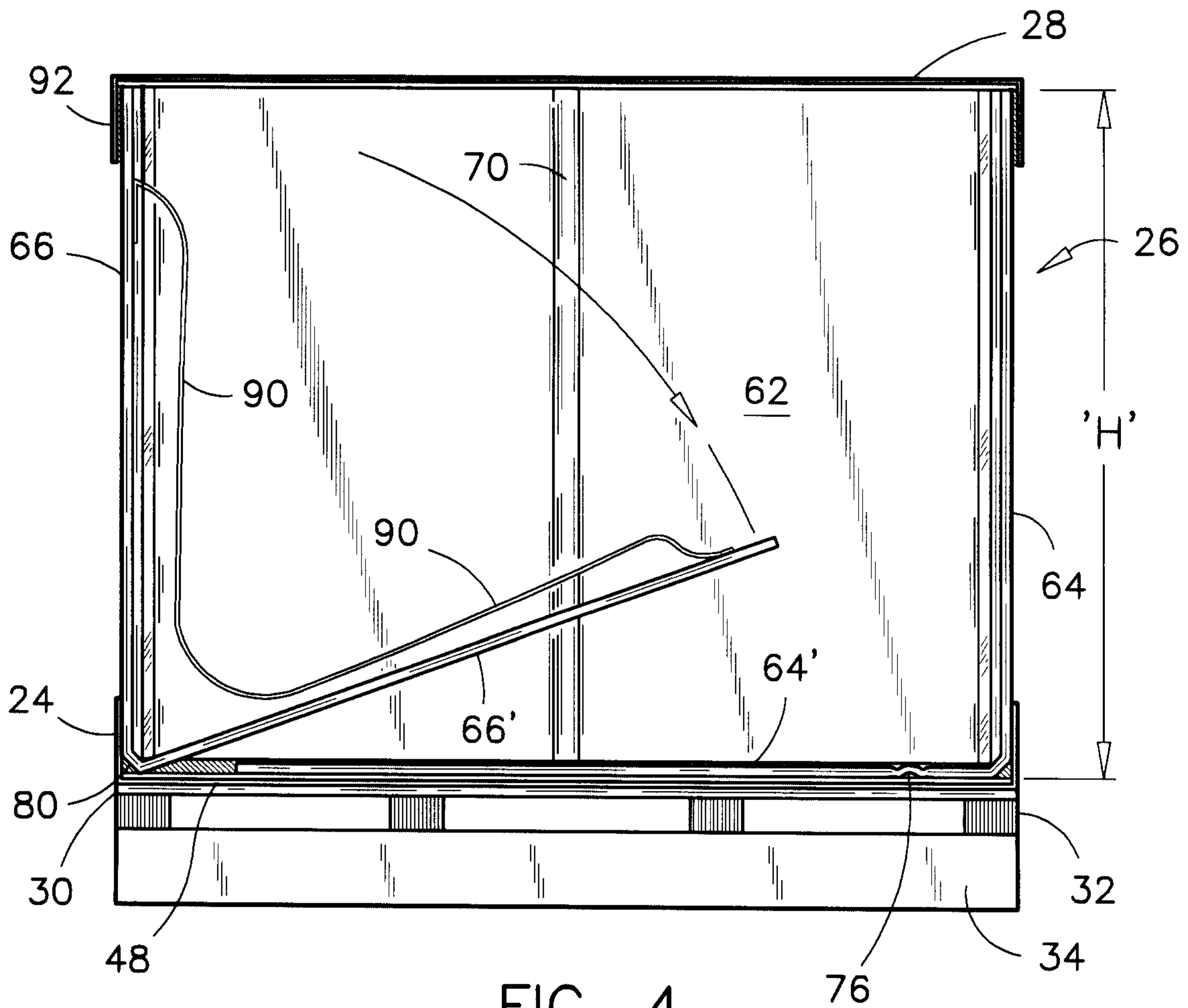

FIG. 4

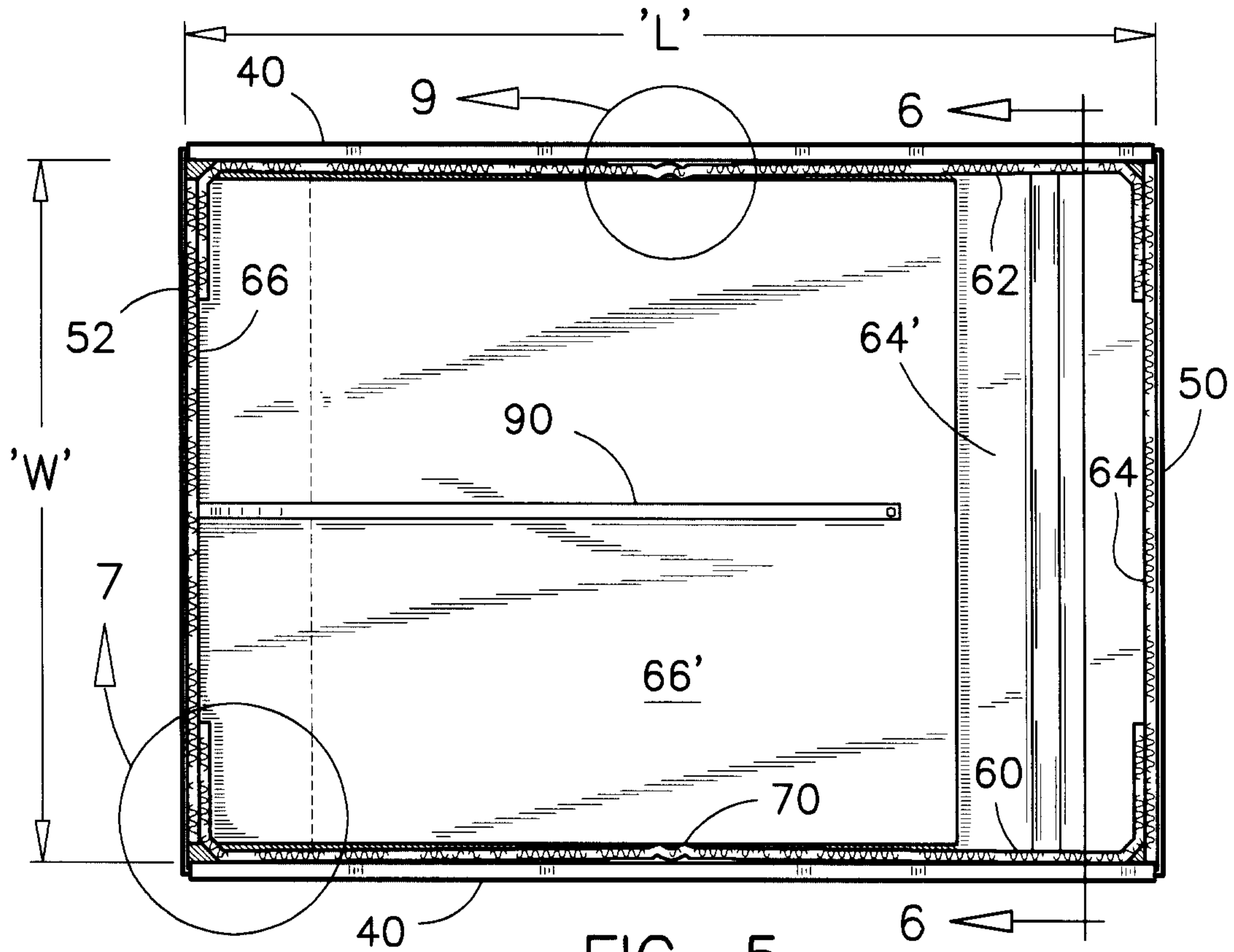

FIG. 5

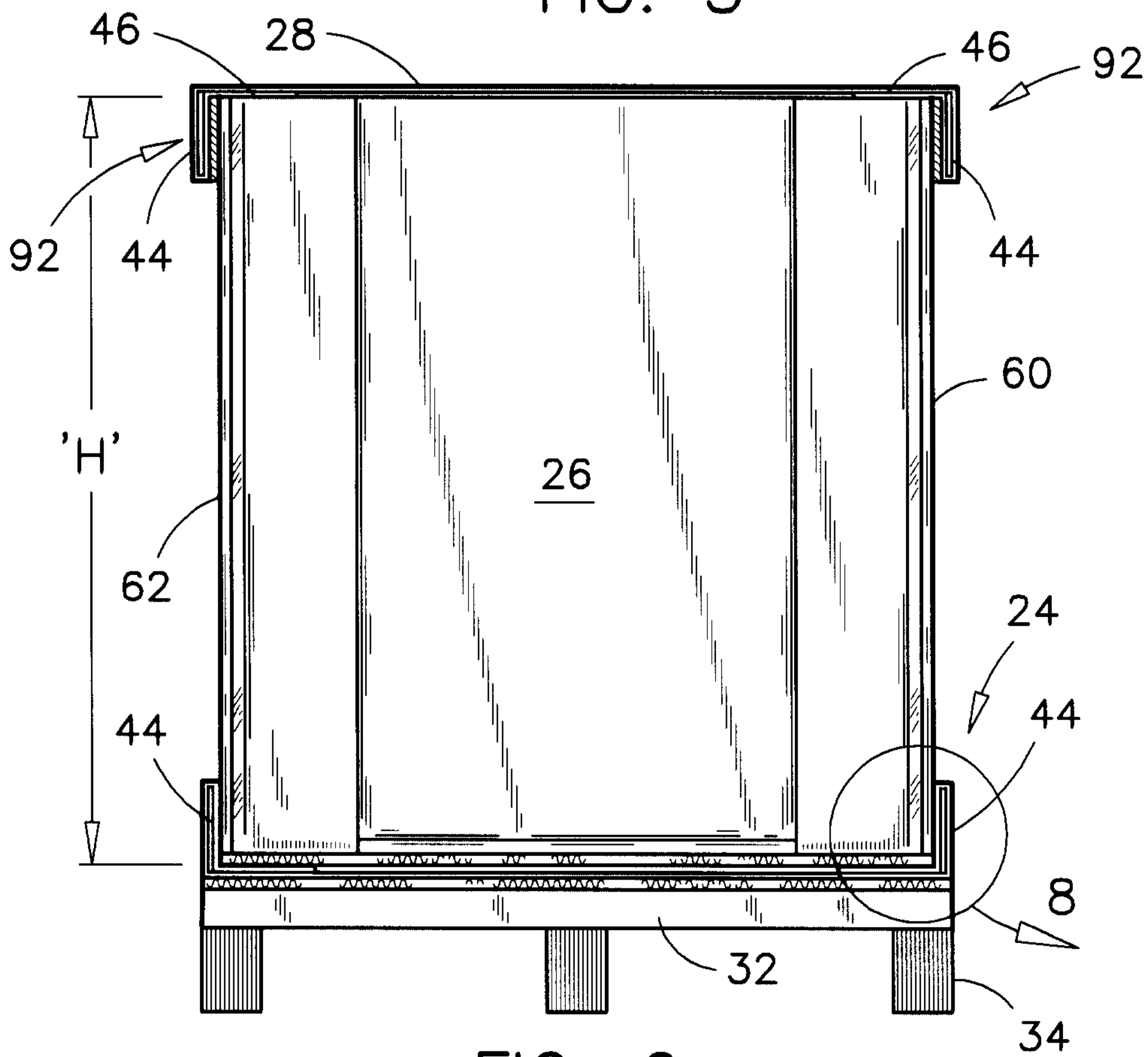

FIG. 6

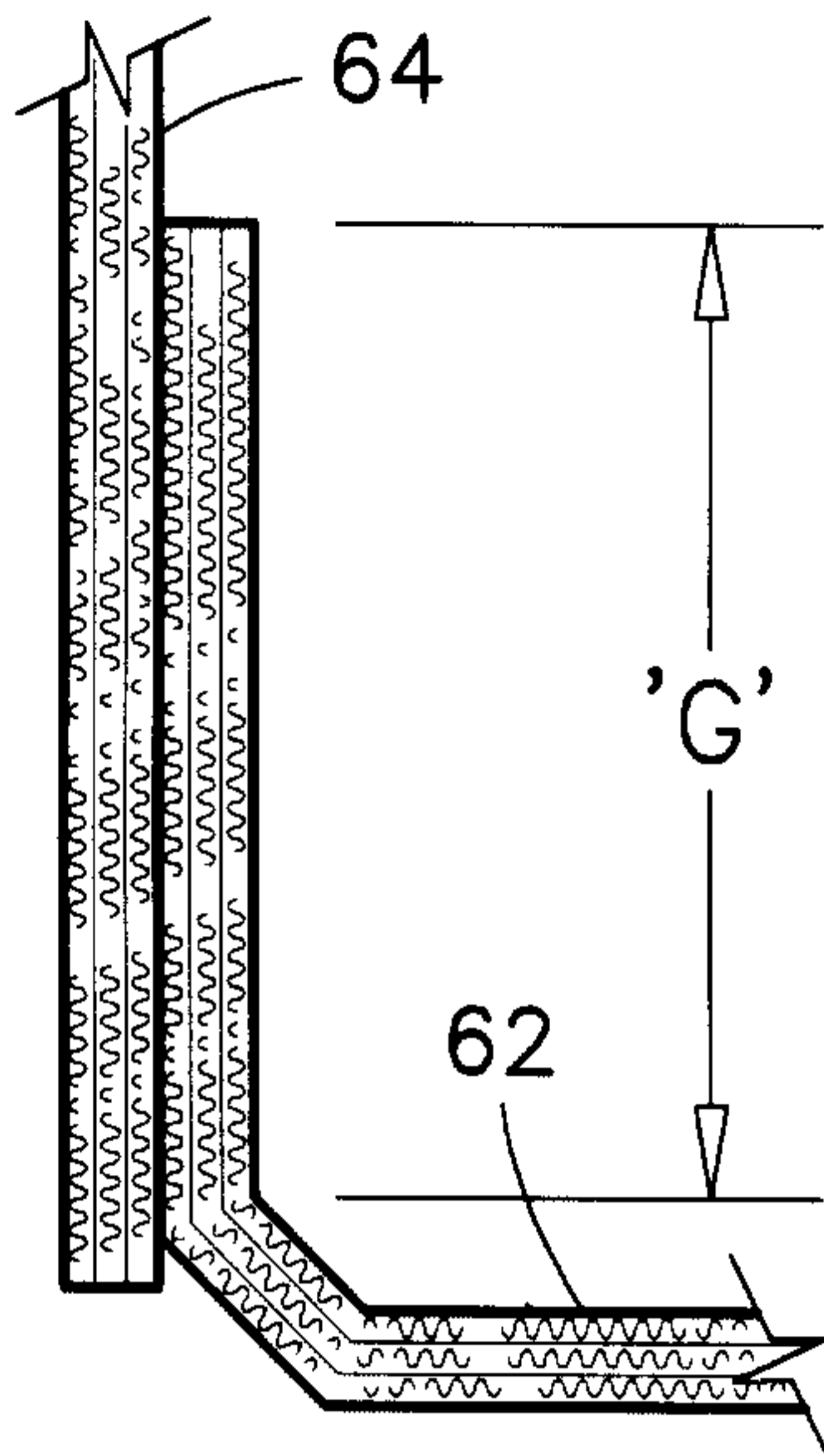
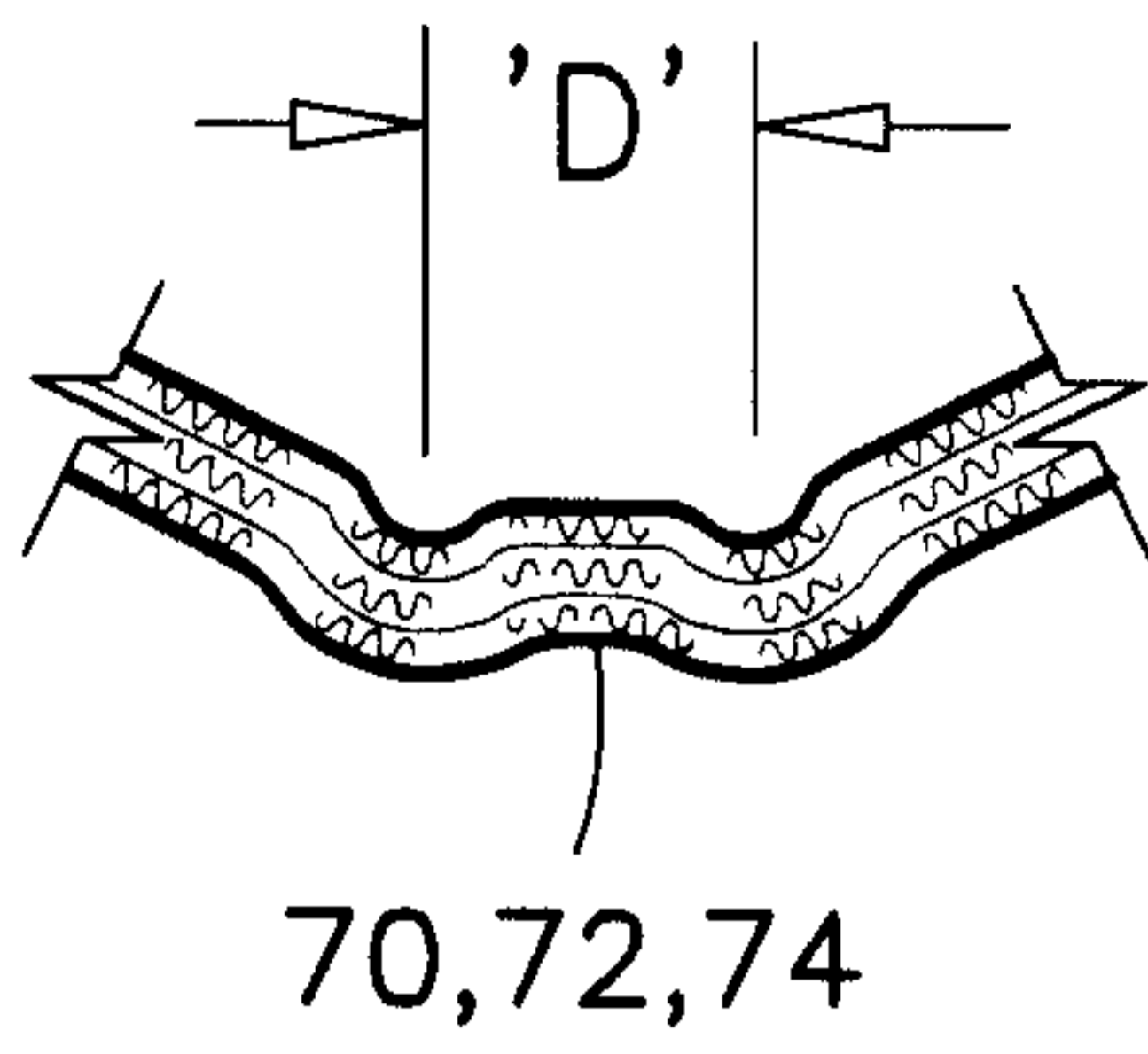

FIG. 7



70,72,74

FIG. 9

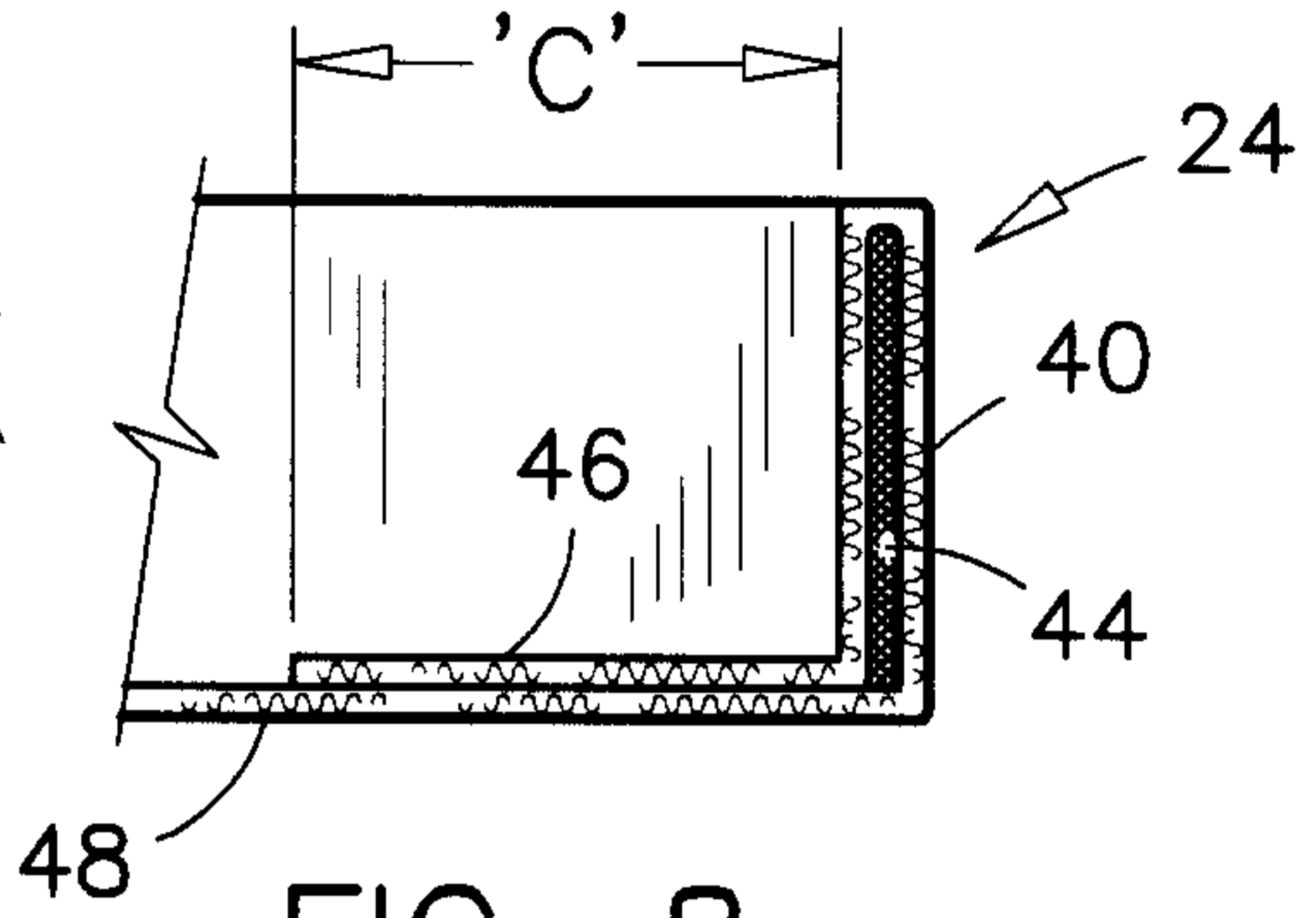

FIG. 8

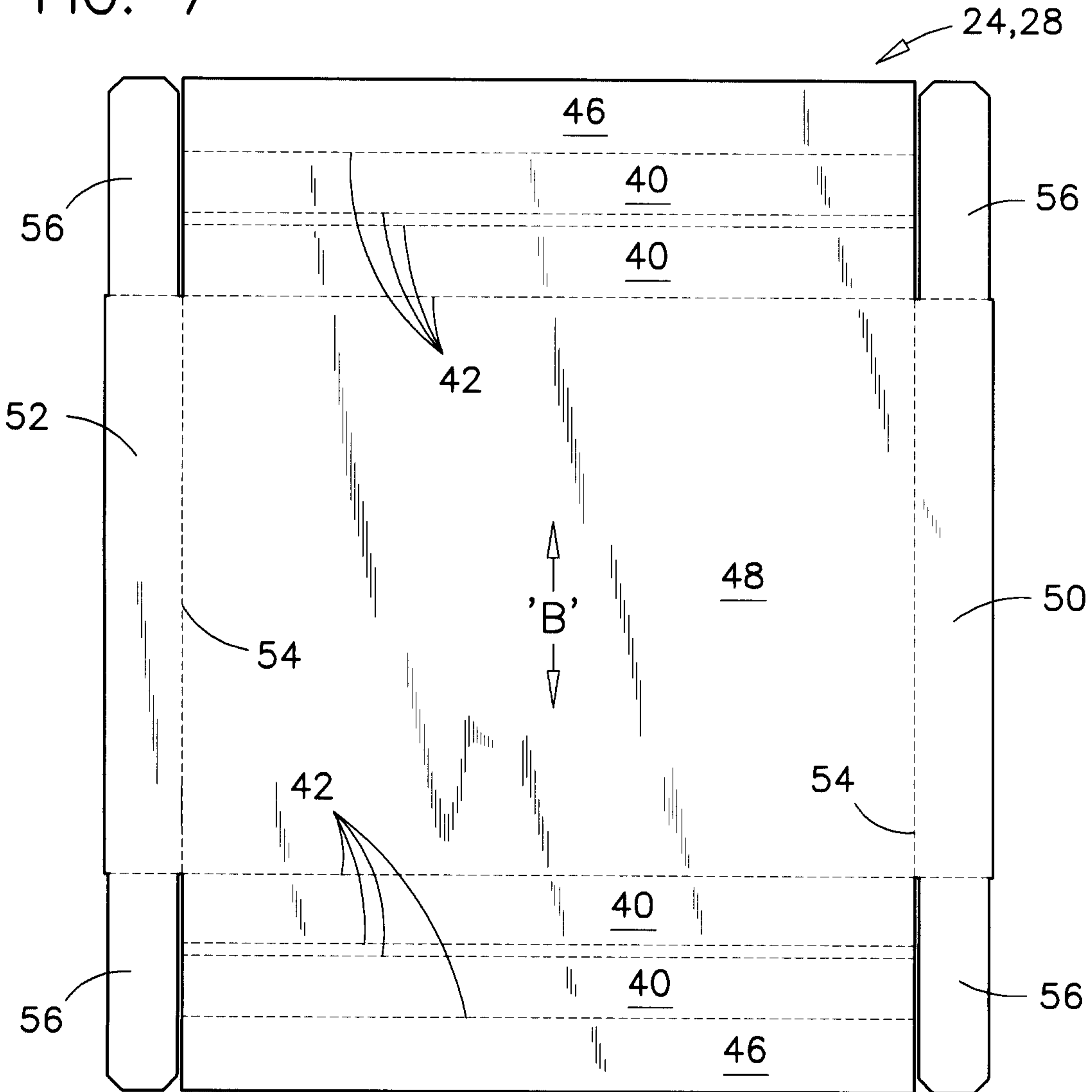

FIG. 10



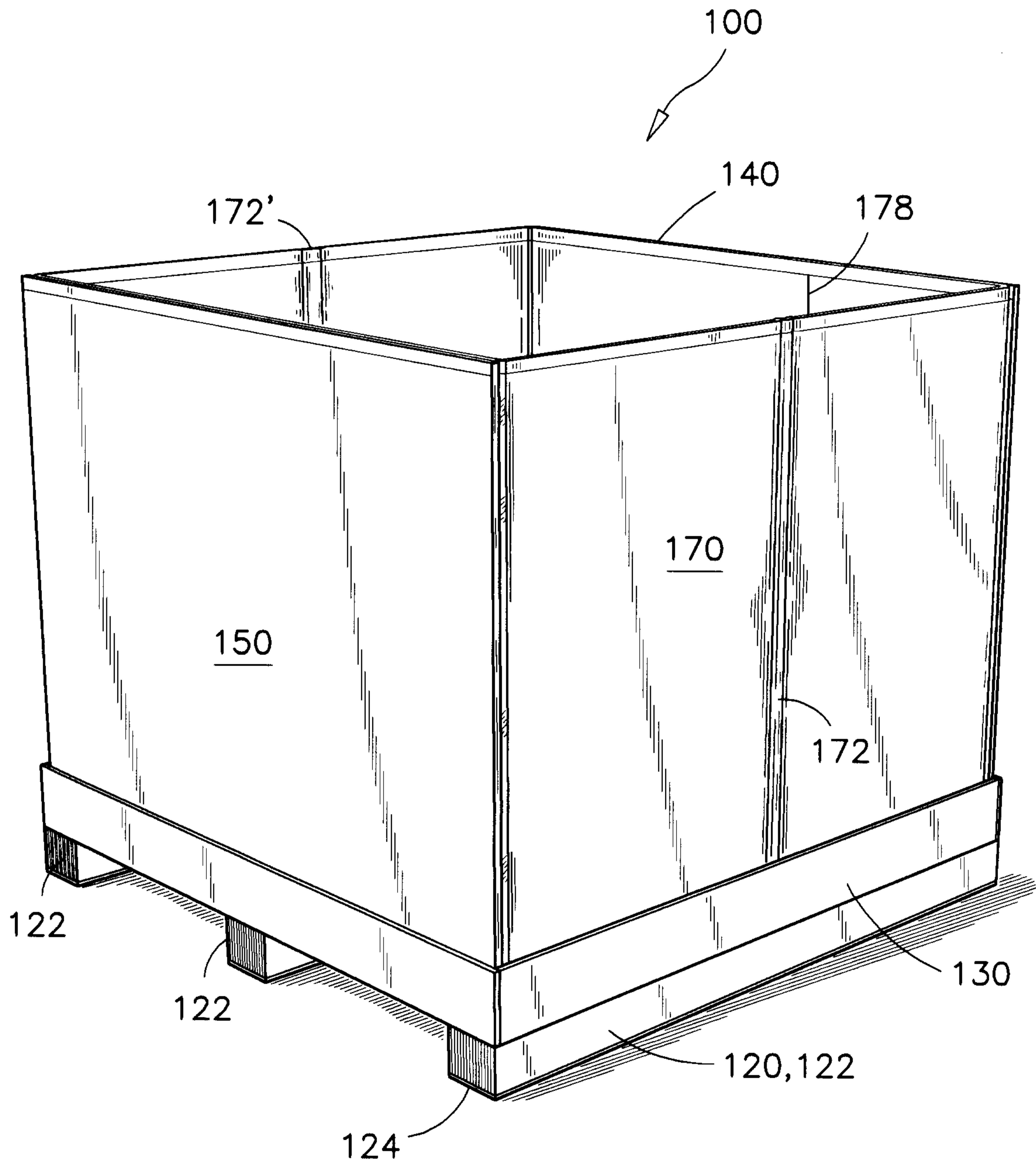

FIG. 11

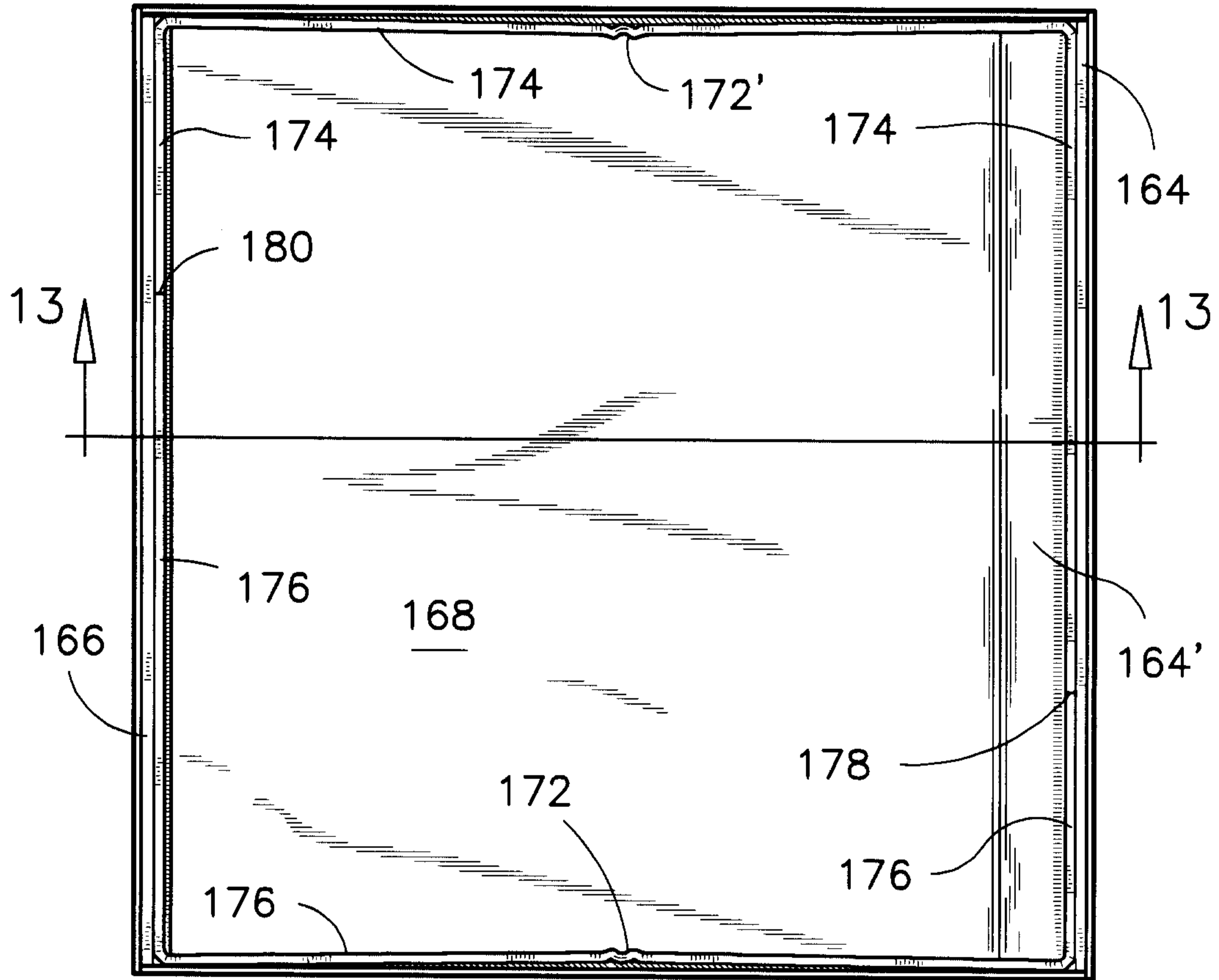

FIG. 12

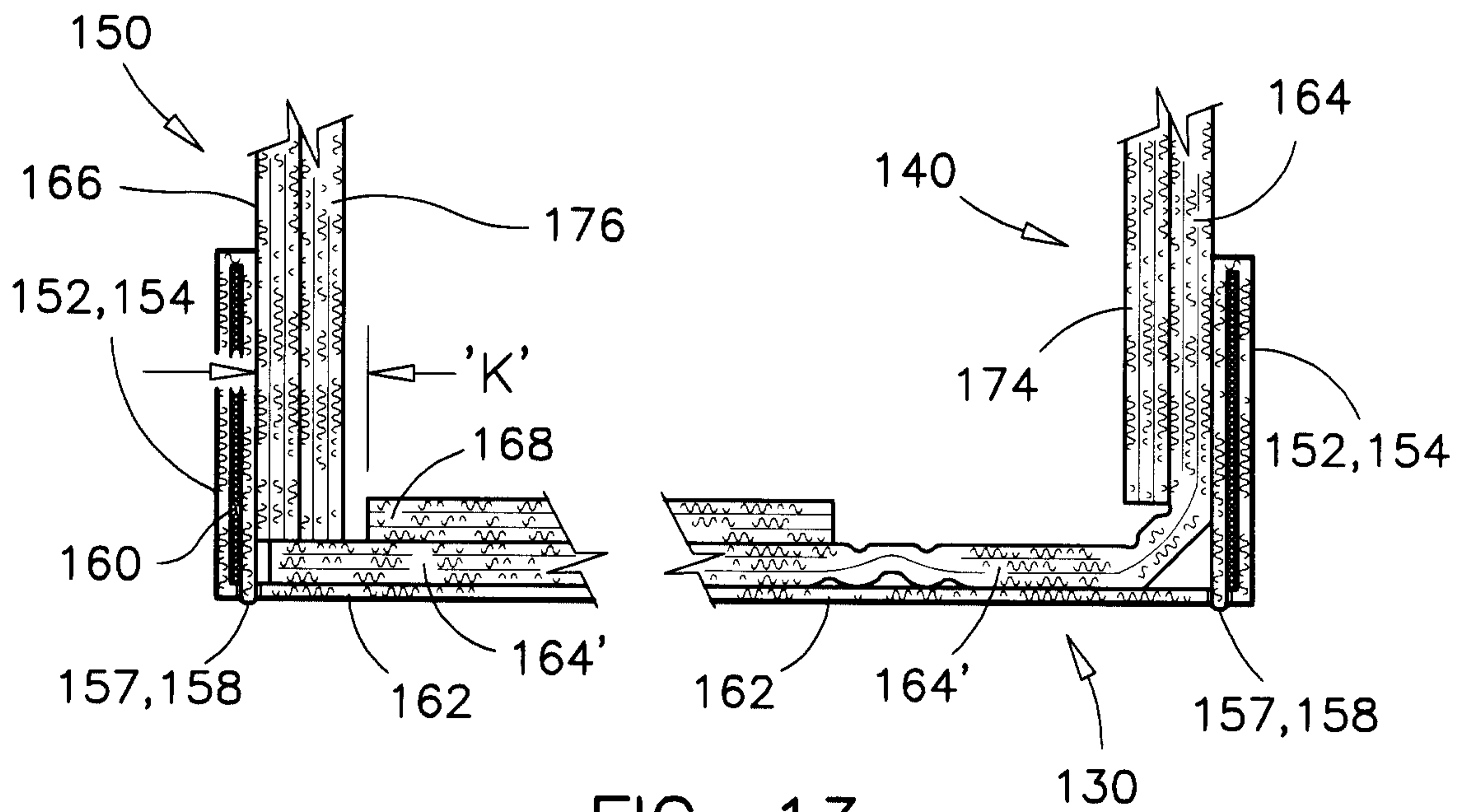

FIG. 13

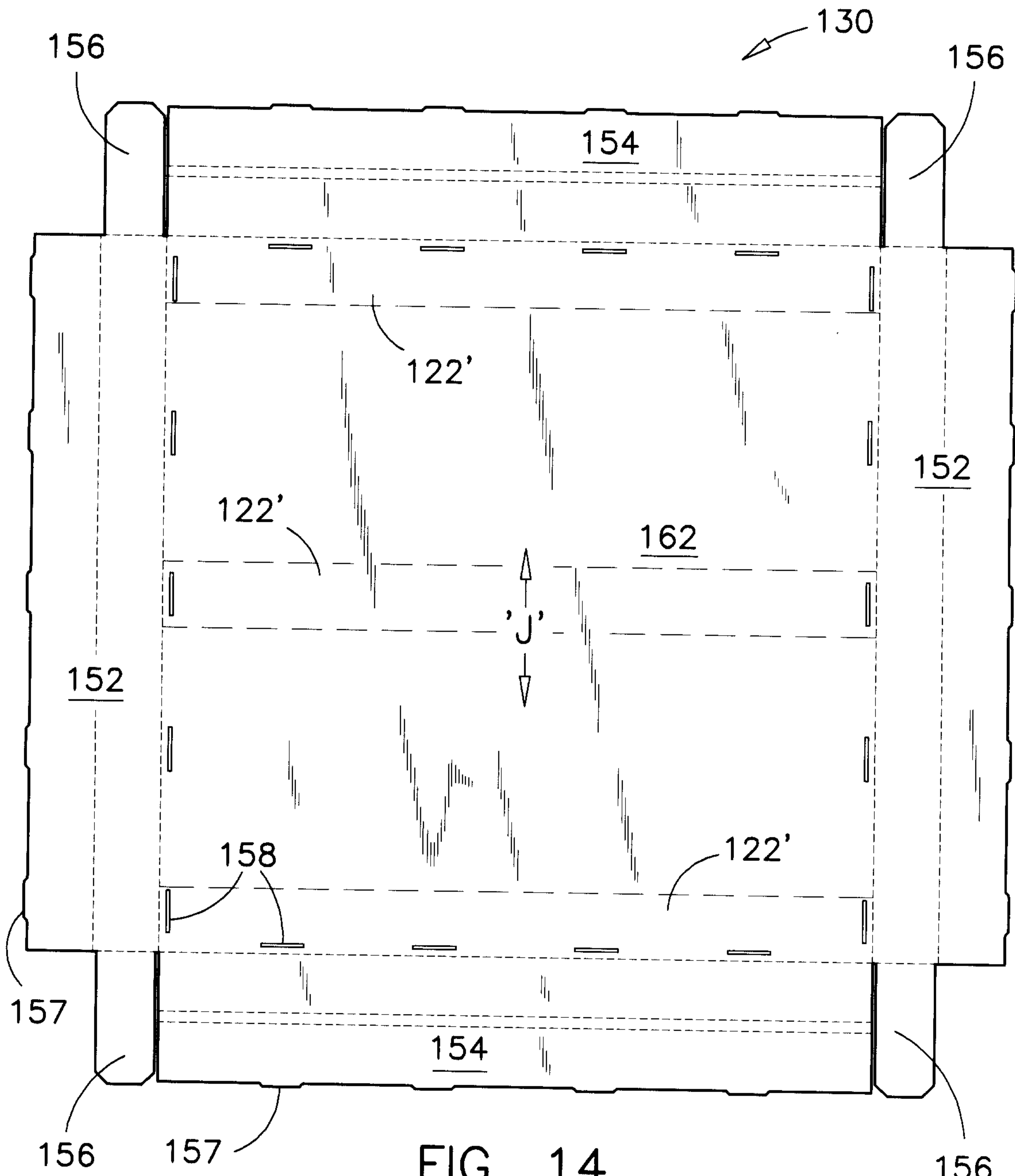

FIG. 14

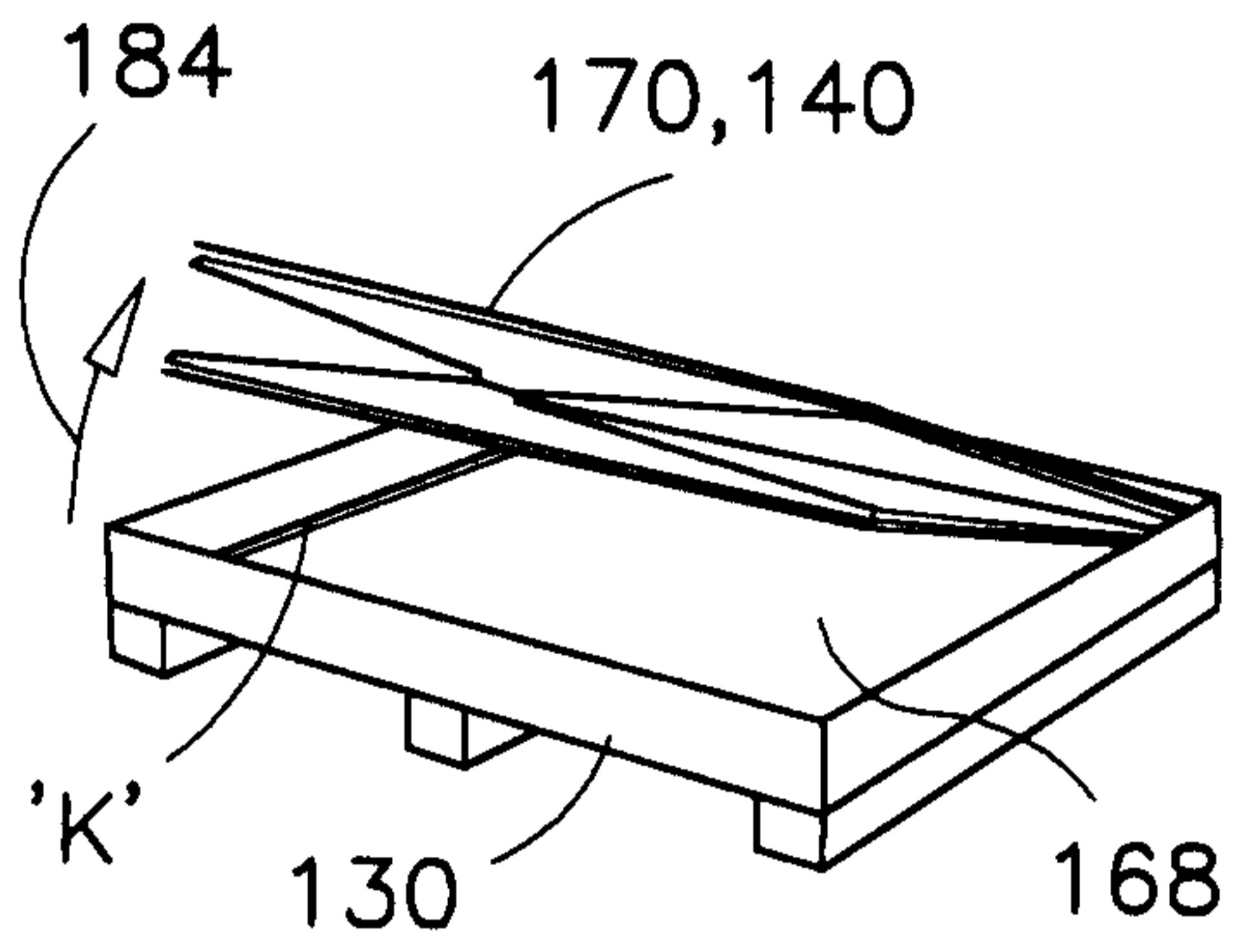

FIG. 15

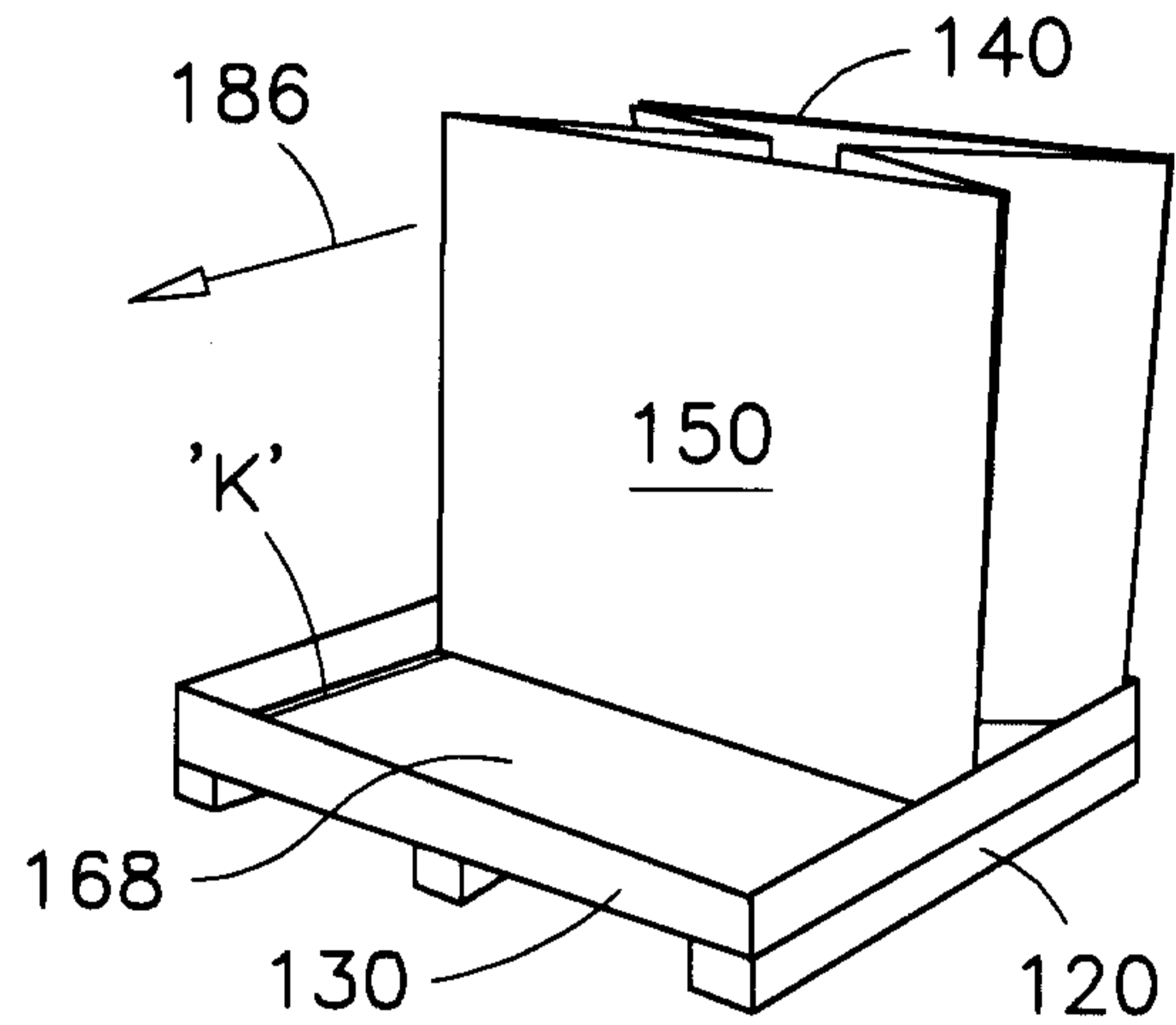

FIG. 16

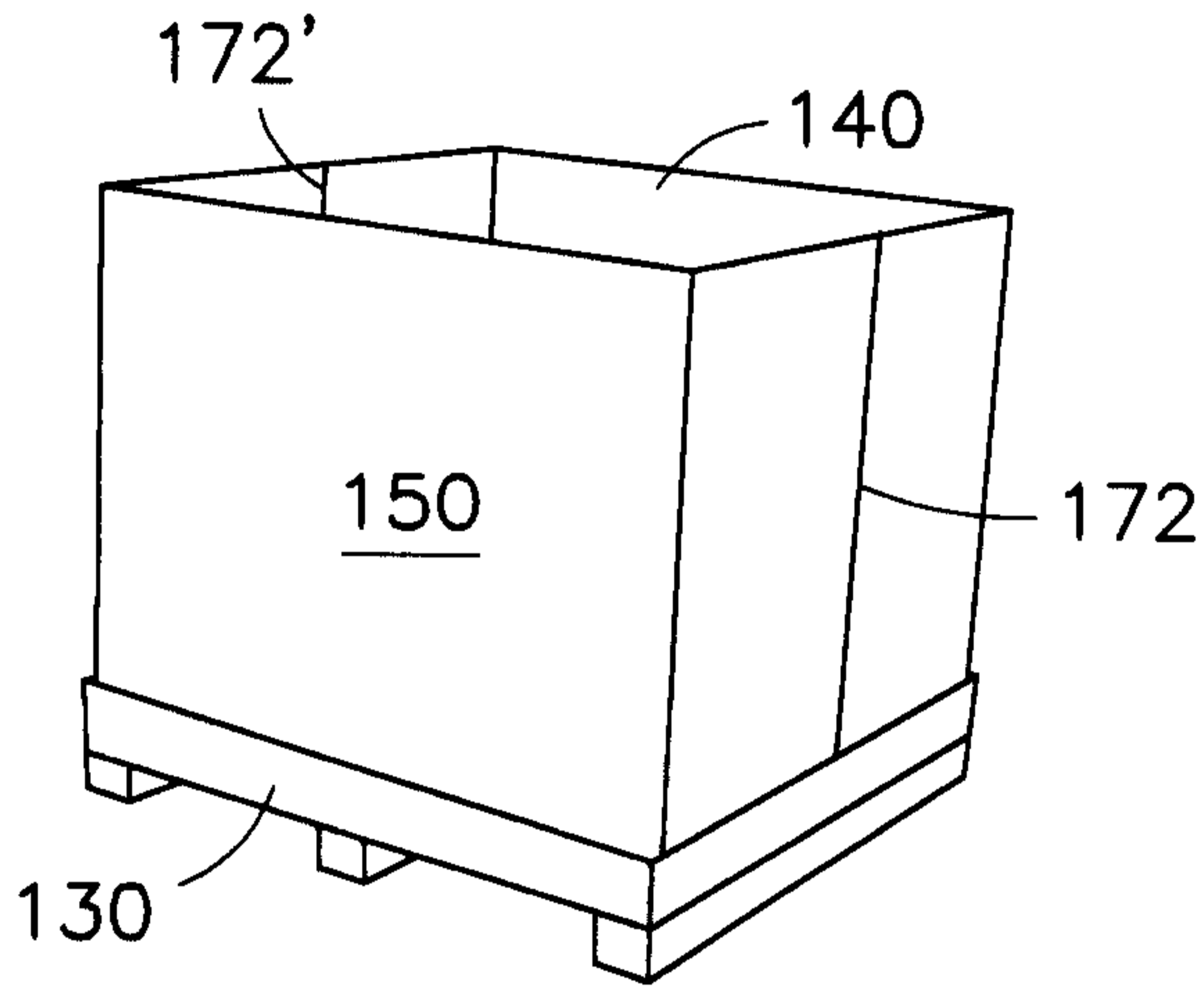

FIG. 17

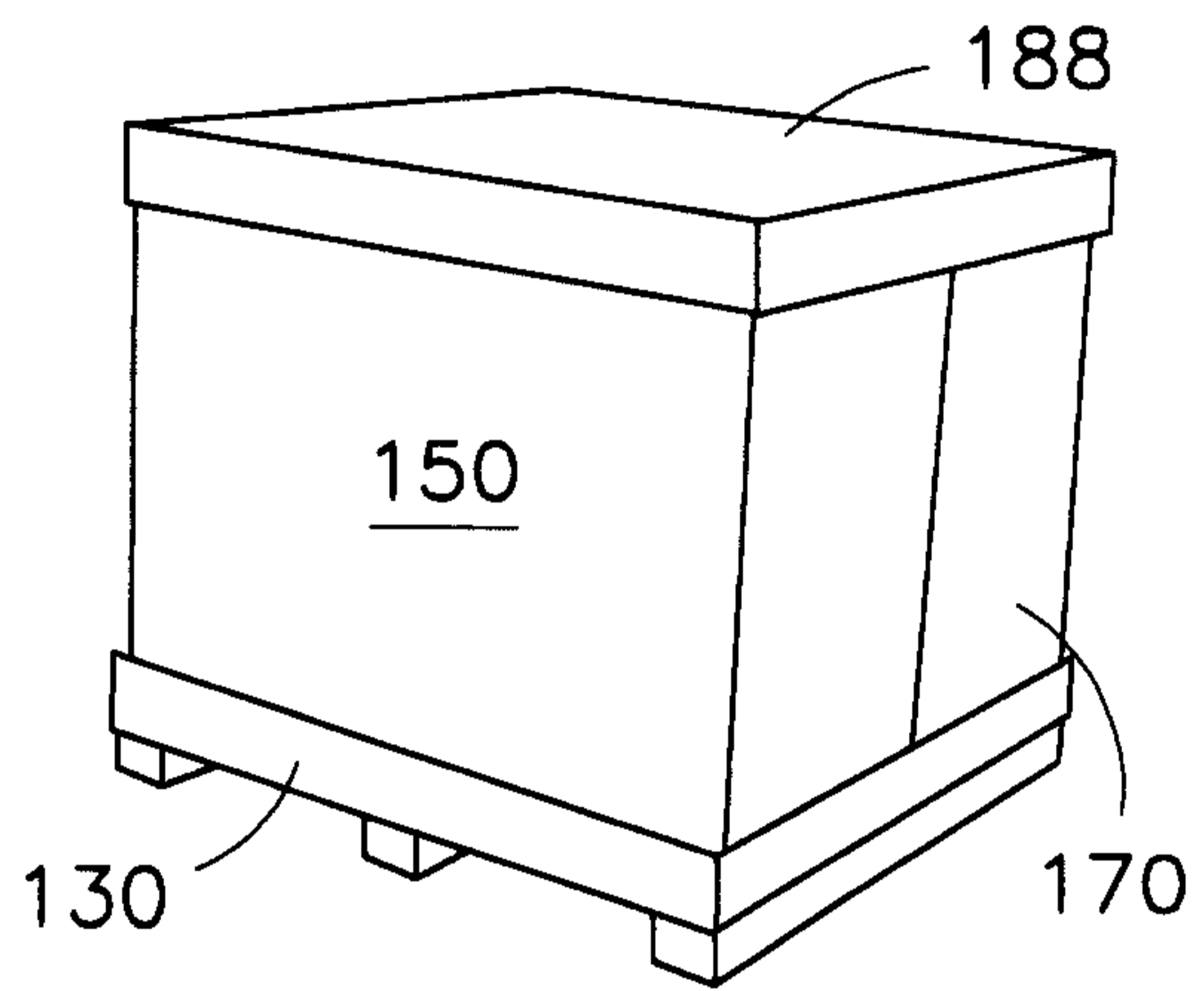

FIG. 18

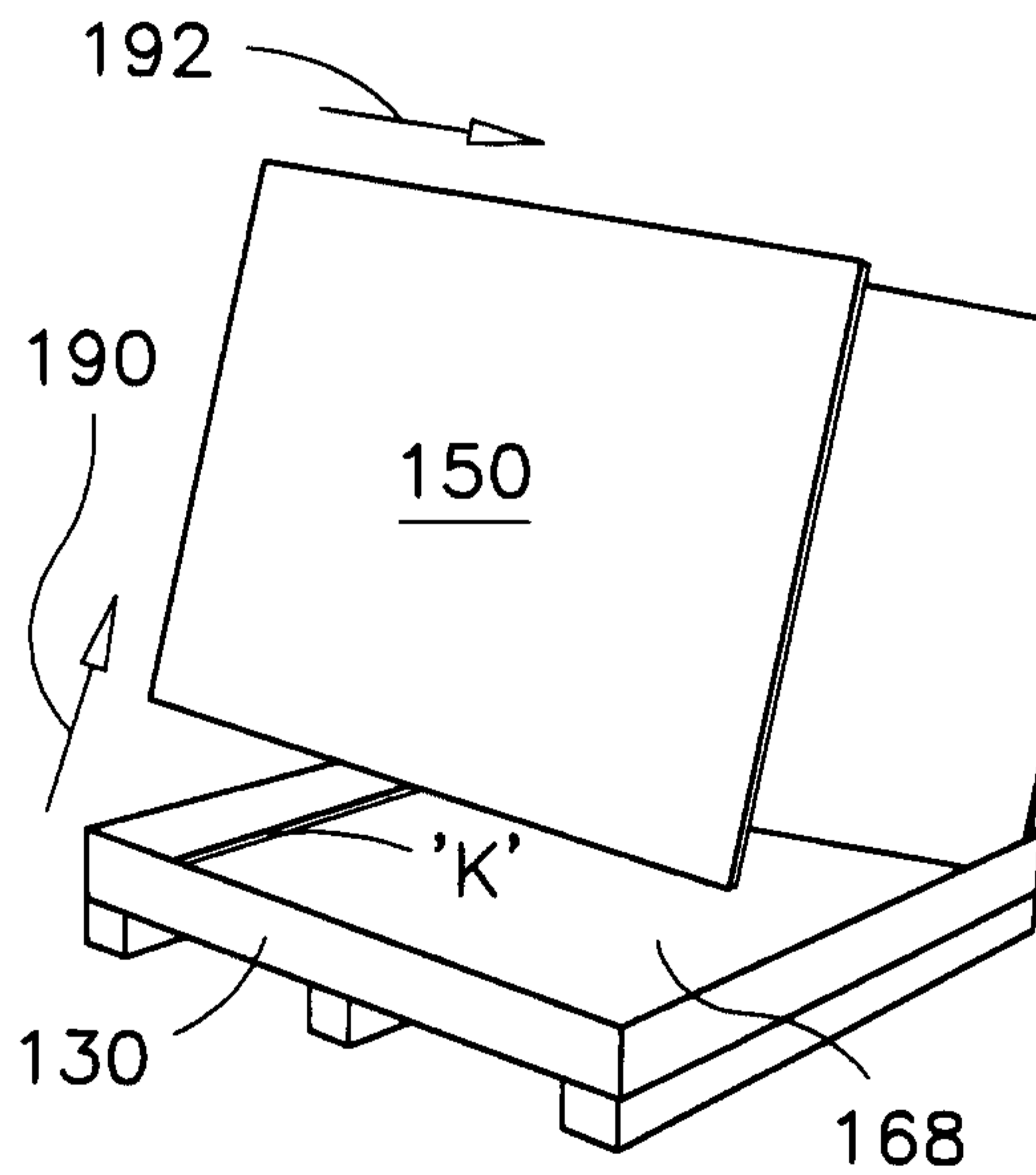

FIG. 19

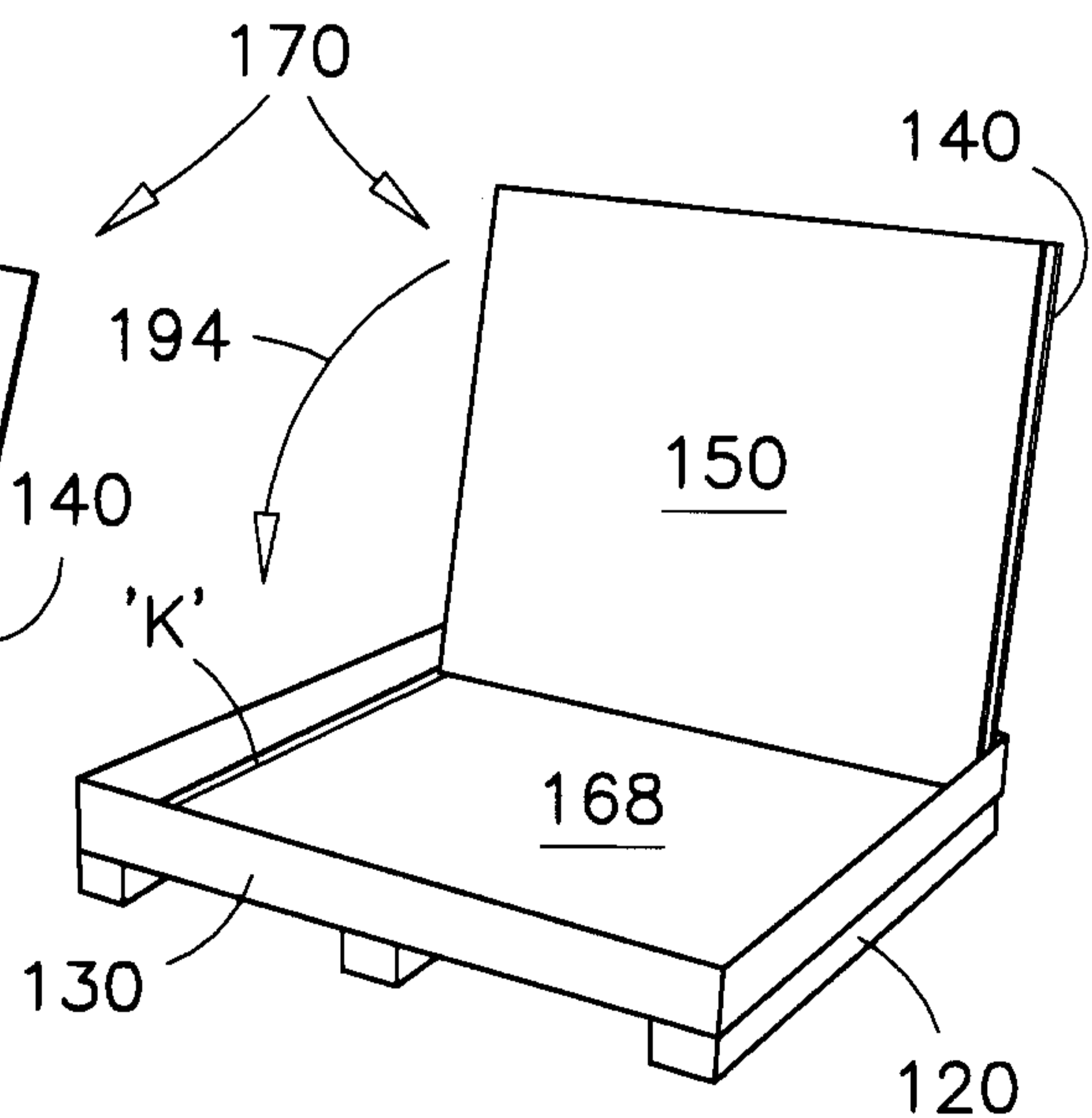

FIG. 20

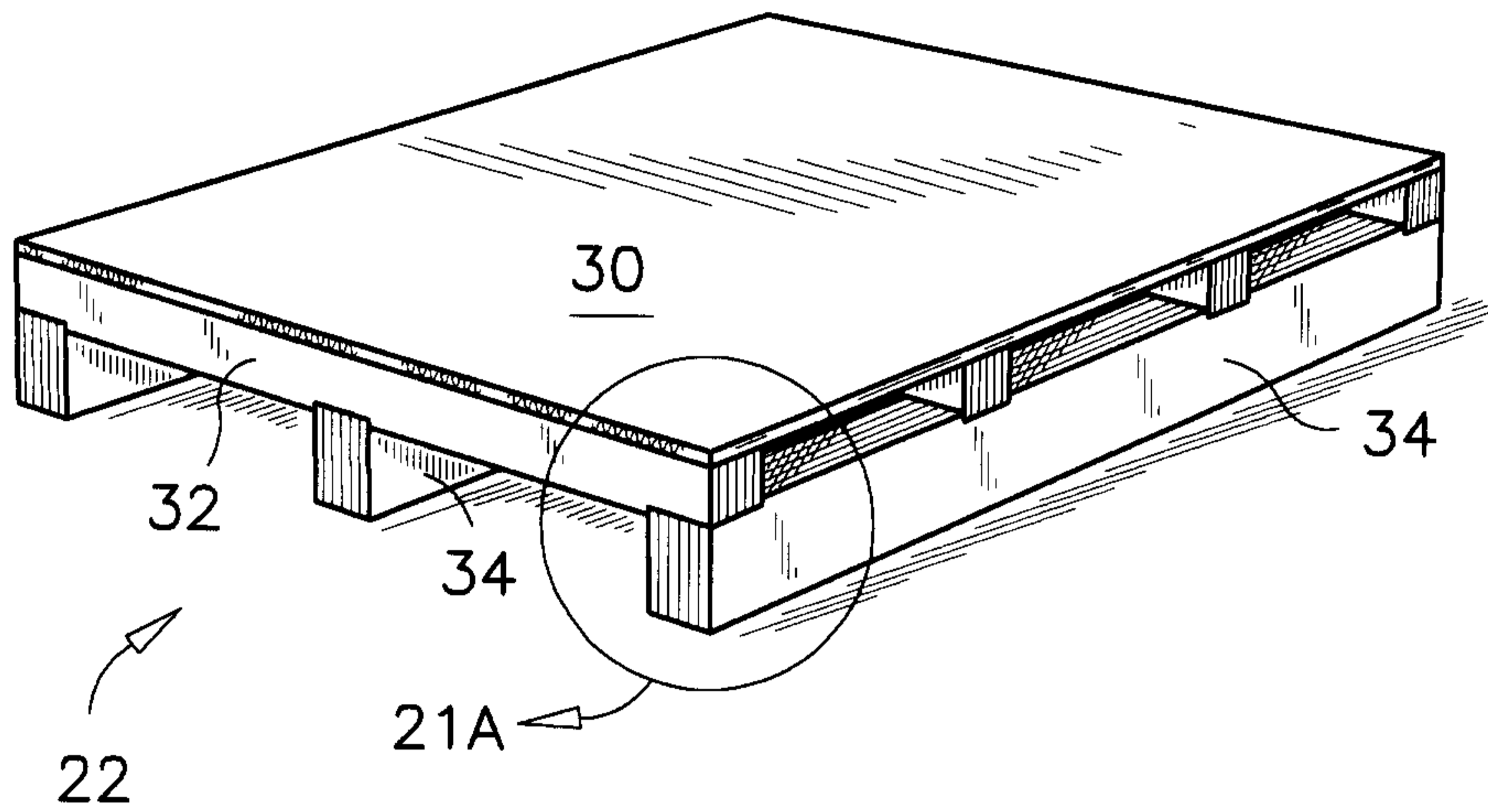

FIG. 21

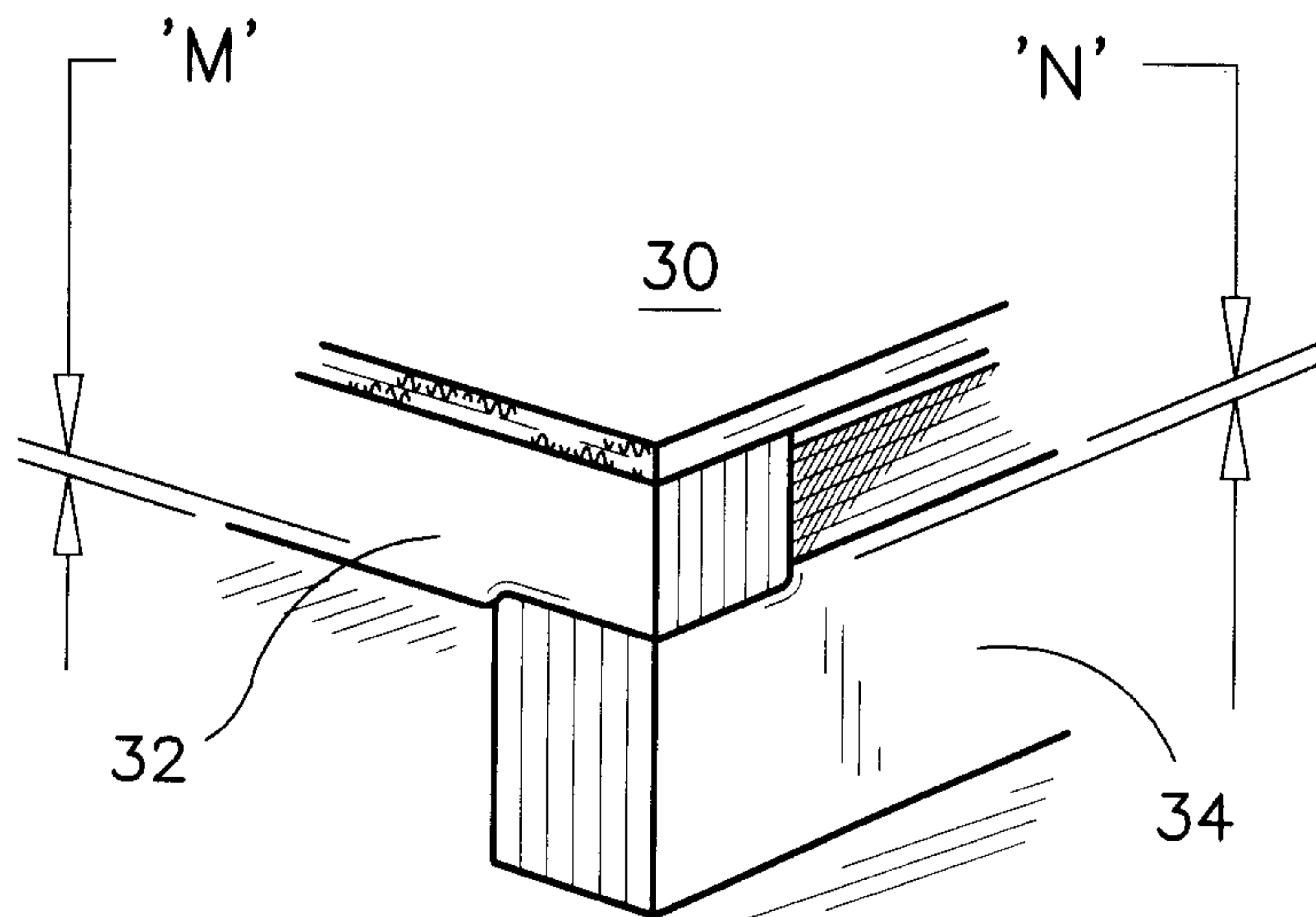

FIG. 21A

