

(19) World Intellectual Property Organization  
International Bureau



(43) International Publication Date  
20 July 2006 (20.07.2006)

PCT

(10) International Publication Number  
WO 2006/074995 A1

(51) International Patent Classification:  
B60S 1/40 (2006.01)

(21) International Application Number:  
PCT/EP2006/050119

(22) International Filing Date: 10 January 2006 (10.01.2006)

(25) Filing Language: English

(26) Publication Language: English

(30) Priority Data:  
05100210.3 14 January 2005 (14.01.2005) EP

(71) Applicant (for all designated States except US): FEDERAL-MOGUL S.A. [BE/BE]; Avenue Champion, B-6790 Aubange (BE).

(72) Inventor; and

(75) Inventor/Applicant (for US only): BOLAND, Xavier [BE/BE]; 304, Rue de Luxembourg, B-6700 Arlon (BE).

(74) Agent: HOOVELD, Arjen Jan Winfried; Arnold & Siedsma, Sweelinckplein 1, NL-2517 GK The Hague (NL).

(81) Designated States (unless otherwise indicated, for every kind of national protection available): AE, AG, AL, AM, AT, AU, AZ, BA, BB, BG, BR, BW, BY, BZ, CA, CH, CN, CO, CR, CU, CZ, DE, DK, DM, DZ, EC, EE, EG, ES, FI, GB, GD, GE, GH, GM, HR, HU, ID, IL, IN, IS, JP, KE, KG, KM, KN, KP, KR, KZ, LC, LK, LR, LS, LT, LU, LV, LY, MA, MD, MG, MK, MN, MW, MX, MZ, NA, NG, NI, NO, NZ, OM, PG, PH, PL, PT, RO, RU, SC, SD, SE, SG, SK, SL, SM, SY, TJ, TM, TN, TR, TT, TZ, UA, UG, US, UZ, VC, VN, YU, ZA, ZM, ZW.

(84) Designated States (unless otherwise indicated, for every kind of regional protection available): ARIPO (BW, GH, GM, KE, LS, MW, MZ, NA, SD, SL, SZ, TZ, UG, ZM, ZW), Eurasian (AM, AZ, BY, KG, KZ, MD, RU, TJ, TM), European (AT, BE, BG, CH, CY, CZ, DE, DK, EE, ES, FI, FR, GB, GR, HU, IE, IS, IT, LT, LU, LV, MC, NL, PL, PT, RO, SE, SI, SK, TR), OAPI (BF, BJ, CF, CG, CI, CM, GA, GN, GQ, GW, ML, MR, NE, SN, TD, TG).

Published:  
— with international search report

For two-letter codes and other abbreviations, refer to the "Guidance Notes on Codes and Abbreviations" appearing at the beginning of each regular issue of the PCT Gazette.

(54) Title: WINDSHIELD WIPER DEVICE

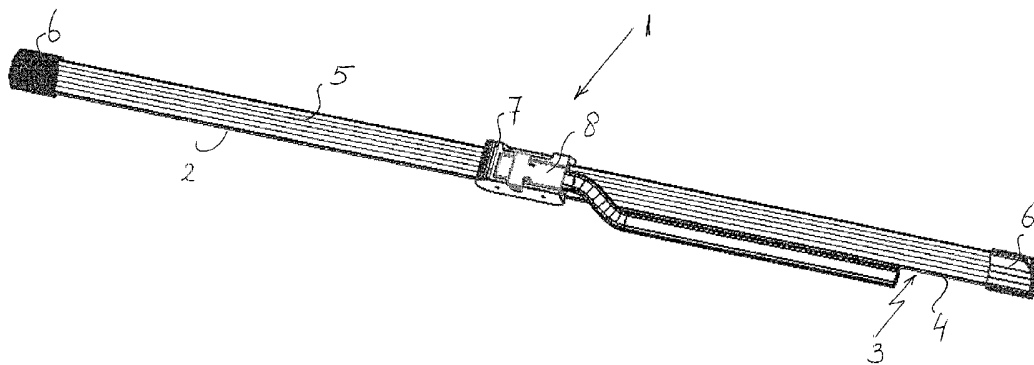

(57) Abstract: A windscreen wiper device (1) comprising an elastic, elongated carrier element, as well as an elongated wiper blade (2) of a flexible material, which can be placed in abutment with a windscreen to be wiped, which wiper blade includes opposing longitudinal grooves (3) on its longitudinal sides, in which grooves spaced-apart longitudinal strips (4) of the carrier element are disposed, wherein neighbouring ends of said longitudinal strips are interconnected by a respective connecting piece (6), which windscreen wiper device comprises a connecting device (7) for an oscillating arm (8), wherein said oscillating arm is pivotally connected to said connecting device about a pivot axis near one end, with the special feature that said connecting device comprises at least two parts provided with protrusion/hole means for detachably connecting said parts together, wherein the first part is retained onto the wiper blade and wherein the second part has an at least substantially U-shaped cross-section at the location of its connection to said first part, wherein each leg of said U-shaped cross-section is allowed to bend outwardly upon insertion of the oscillating arm into said second part for connecting said first and second parts together through a snapping operation.

WO 2006/074995 A1

**WINDSHIELD WIPER DEVICE**

5 The present invention relates to a windscreen wiper device comprising an elastic, elongated carrier element, as well as an elongated wiper blade of a flexible material, which can be placed in abutment with a windscreen to be wiped, which wiper blade includes opposing longitudinal grooves on its  
10 longitudinal sides, in which grooves spaced-apart longitudinal strips of the carrier element are disposed, wherein neighbouring ends of said longitudinal strips are interconnected by a respective connecting piece, which windscreen wiper device comprises a connecting device for an  
15 oscillating arm, wherein said oscillating arm is pivotally connected to said connecting device about a pivot axis near one end.

Such a windscreen wiper device is generally known. This prior  
20 art windscreen wiper device is designed as a "yokeless" wiper device, wherein no use is made of several yokes pivotally connected to each other, but wherein the wiper blade is biased by the carrier element, as a result of which it exhibits a specific curvature.

25 In practice it has become apparent that, during use of the known windscreen wiper device, high forces are exerted on the connection between the connecting device and the oscillating arm. As a consequence thereof the wiper blade may get loose  
30 from the oscillating arm.

The object of the invention is to provide a windscreen wiper device, wherein the connecting device and the oscillating arm

are connected in an improved manner, using a minimum of parts.

5 Thereto, a windscreen wiper device of the type referred to in the introduction is characterized according to the invention in that said connecting device comprises at least two parts provided with protrusion/hole means for detachably connecting said parts together, wherein the first part is retained onto the wiper blade and wherein the second part has an at least  
10 substantially U-shaped cross-section at the location of its connection to said first part, wherein each leg of said U-shaped cross-section is allowed to bend outwardly upon insertion of the oscillating arm into said second part for connecting said first and second parts together through a  
15 snapping operation. Preferably, each leg of said U-shaped cross-section is bendable between a first position, wherein said first and second parts are connected together through a snapping operation upon insertion of the oscillating arm into said second part, and a second position, wherein said first  
20 and second parts are released from each other upon removing the oscillating arm from said second part. In other words, sliding the oscillating arm into the second part of the connecting device results in the legs of the U-shaped cross-section being bend outwardly. As a result the first and the  
25 second parts of the connecting device are automatically snapped, that is clipped onto each other, using the protrusion/hole means. Both parts are automatically released from each other by sliding the oscillating arm off the second part of the connecting device.

30

In one preferred embodiment of a windscreen wiper device in accordance with the invention said first part is provided with opposite abutting surfaces for abutting against the legs

of the U-shaped cross-section, wherein a protrusion extends laterally outwardly from each leg of the U-shaped cross-section into a hole provided on an abutting surface abutting against a respective leg. In the alternative or in addition  
5 thereto, said first part is provided with opposite abutting surfaces for abutting against the legs of the U-shaped cross-section, wherein a protrusion extends laterally inwardly from each abutting surface into a hole provided on a leg abutting against a respective abutting surface.

10

In another preferred embodiment of a windscreen wiper device according to the invention the second part is positioned at least substantially within said first part.

15 In another preferred embodiment of a windscreen wiper device in accordance with the invention said first part comprises engaging members made integral therewith for engaging around the longitudinal sides of the longitudinal strips that face away from each other. In other words, the engaging members  
20 each form a groove for introducing the longitudinal strips therein, so that the first part of the connecting device is firmly retained onto the wiper blade. In order to enhance the retention thereof the the engaging members may be welded, soldered, brazed or glued to the longitudinal strips.

25

In another preferred embodiment of a windscreen wiper device according to the invention said second part comprises at least one resilient tongue engaging in a correspondingly shaped hole provided in the oscillating arm, wherein said  
30 resilient tongue is rotatable along a hinge axis between an outward position retaining the wiper blade onto the oscillating arm and an inward position releasing the wiper blade from the oscillating arm. Particularly, the counterforce exerted by

the oscillating arm on the resilient tongue engages at a point located behind the hinge axis, seen in the direction of the force exerted on the wiper blade. In other words, said moment of force ensures in a natural way that the resilient tongue is forced automatically in its outward position, that is its position retaining the wiper blade onto the oscillating arm.

In another preferred embodiment of a windscreen wiper device in accordance with the invention the hinge axis is located near an outer edge of said joint part.

In another preferred embodiment of a windscreen wiper device according to the invention said hole has a closed circumference. In the alternative, said hole has an open circumference.

In another preferred embodiment of a windscreen wiper device in accordance with the invention said windscreen wiper device is provided with first and second retaining means for retaining said connecting device onto said oscillating arm, wherein said first retaining means comprises said at least one resilient tongue engaging in said correspondingly shaped hole, and wherein said second retaining means comprise at least one protrusion provided on the first part engaging the oscillating arm. Particularly, said protrusion engages into a correspondingly shaped hole with a closed circumference provided on the oscillating arm. More in particular, said protrusion engages into a correspondingly shaped hole with an open circumference provided on a longitudinal side of the oscillating arm. Even more in particular, said protrusion engages into a correspondingly shaped recess provided on the oscillating arm.

The invention will now be explained in more detail with reference to figures illustrated in a drawing, wherein

- 5 - Figure 1 is a perspective, schematic view of a preferred embodiment of a windscreen wiper device according to the invention;
- 10 - Figure 2 shows various successive steps for fitting the connecting device and the oscillating arm of figure 1 together;
- 15 - Figure 3 is a perspective, schematic view of the first and the second parts of the connecting device of figure 2, seen from beneath and from above, respectively;
- Figure 4 refers to a perspective, schematic view of the free end of the oscillating arm of figure 2;
- 20 - Figure 5 shows a perspective, schematic view of the first part of the connecting device and the free end of the oscillating arm in accordance with another preferred embodiment, seen from above, respectively; and
- 25 - Figure 6 is a perspective, schematic view of the first part of the connecting device and the free end of the oscillating arm in accordance with yet another preferred embodiment, seen from above, respectively.

30 Figure 1 shows a windscreen wiper device 1 of the "yokeless" type according to the invention. Said windscreen wiper device is built up of an elastomeric wiper blade 2, in the longitudinal sides of which opposing longitudinal grooves 3 are formed, and of longitudinal strips 4 made of spring band

steel, which are fitted in said longitudinal grooves 3. Said strips 4 form a flexible carrier element for the rubber wiper blade 2, as it were, which is thus biased in a curved position (the curvature in operative position being that of a  
5 windscreen to be wiped). Neighbouring ends of strips 4 are interconnected on either side of the windscreen wiper device 1 by means of connecting pieces 6 functioning as clamping members. In this embodiment, the connecting pieces 6 are separate constructional elements, which may be form-locked  
10 ("positive locking" or "having positive fit") as well as force-locked to the ends of strips 4. In another preferred variant, said connecting pieces 6 are in one piece with the strips 4 made of spring band steel. In the latter case said connecting pieces form transverse bridges for the strips 4,  
15 as it were. Possibly, a spoiler 5 is furthermore provided.

The windscreen wiper device 1 is furthermore built up of a connecting device 7 of plastic material for an oscillating wiper arm 8. Said wiper arm 8 is finalized by an extension  
20 (without an adapter). Connecting device 7 consists of a first part 7' and a second part 7'' detachably connected together, wherein said first part 7' is retained onto the wiperblade 2 and wherein said second part 7'' is positioned within said first part 7'. Said first part 7' has a U-shaped cross-  
25 section and comprises clamping members that are integral therewith, which engage round longitudinal sides of the strips 4 that face away from each other, as a result of which the connecting device 7 is firmly attached to the unit consisting of wiper blade 2 and strips 4. The oscillating  
30 wiper arm 8 is pivotally connected to the connecting device 7 about a pivot axis near one end, and that in the following manner.

With reference to figure 2 said second part 7" comprises two cylindrical protrusions 10 extending outwards on either side of said second part 7" (figure 2a). These protrusions 10 pivotally engage in identically shaped cylindrical holes 11 of said part 7' (figure 2b). After said second part 7" is placed into said first part 7' (with play) by hand, the free end 9 of the oscillating arm 8 is inserted into said second part 7" (figure 2b). As a consequence thereof each leg 12 of the U-shaped cross-section of the second part 7" is allowed to bend outwardly resulting in a click or snap connection between both parts 7' and 7" (figure 2c). Said protrusions 10 act as bearing surfaces at the location of a pivot axis in order to pivot the second part 7" (and the oscillating wiper arm 8 attached thereto) about said pivot axis near one end 9 of said arm 8. The protrusions 10 are preferably in one piece with said second part 7"; in the alternative, the protrusions 10 are part of a single pivot pin perpendicular to the connecting device 7. Said connecting device 7 may be equipped with a cover or cap in order to obtain an aesthetic appearance thereof, to avoid sharp edges and to provide protection against UV-light etcetera.

Referring to figures 3a and 4, the second part 7" comprises a resilient tongue 13 extending inwardly, while the oscillating arm 8 has an identically shaped hole 14 with a closed circumference at the location of its connection to said second part 7", so that said tongue 13 engages in said hole 14 (figure 4). While mounting the oscillating wiper arm 8 into said second part 7', the resilient tongue 13 is initially pushed out against a spring force and then allowed to spring back into said hole 14, thus snapping, that is clipping the resilient tongue 13 into the hole 14. This is a so-called bayonet-connection. As can be seen from figure 3a,



the second part 7" is provided with a channel-like section 15 for receiving the free end 9 of the oscillating arm 8.

The resilient tongue 13 on said second part 7'' and the hole 5 14 in the oscillating arm 8 are meant for retaining the connecting device 7 onto the oscillating arm 8 and are therefore called "first retaining means". However, in case the first retaining means would disfunction, for example when the resilient tongue 13 would not properly fit into the hole 10 14, the second part 7'' and the first part 7' connected thereto would be able to move relative to the oscillating arm 8 in longitudinal direction of the wiper blade 2. In order to avoid the wiper blade 2 from coming loose, with all negative consequences involved, second retaining means are provided 15 for. Said second retaining means consist of an upwardly extending protrusion 16 on said first part 7' cooperating with a second hole 17 having a closed circumference in the oscillating arm 8 (figures 3b and 4). Said protrusion 16 may also be called a cam.

20

Figures 5A and 5B refer to another preferred embodiment, wherein alternative second retaining means are shown in the sense that the first part 7' comprises an upwardly extending protrusion or cam 18 cooperating with a notch 19 at the 25 location of a longitudinal edge of the oscillating arm 8. Said notch 19 has opposite stop surfaces 20,21 so that the protrusion 18 in assembled position is present between said stop surfaces 20,21.

30 In figures 6A and 6B yet another preferred embodiment is shown, wherein an upwardly extending protrusion or cam 22 on the first part 7' cooperates with a recess 23 at the location of a longitudinal edge of the oscillating arm 8. Said recess

23 is provided with opposite stop surfaces 24,25 for accommodating the protrusion 18 between these stop surfaces 24,25 in assembled position.

5 For mounting or dismounting the connecting device 7 onto or from the oscillating arm 8, the second part 7'' and thus the free end 9 of the oscillating arm 8 connected thereto is pivoted relative to the first part 7' (figures 2A through 2C). While carrying out the pivot movement the protrusion or  
10 cam 16,18,22 is no longer in line with the hole 17,19 or the recess 23 and cannot mutually cooperate any longer, so that the second part 7'' and the first part 7' attached thereto can be released from the oscillating arm 8. This can, of course, only be done when also the resilient tongue 13 in all  
15 embodiments is released from the hole 14.

The invention is not restricted to the variants shown in the drawing, but it also extends to other embodiments that fall within the scope of protection.

**CLAIMS**

1. A windscreen wiper device comprising an elastic,  
elongated carrier element, as well as an elongated wiper  
5 blade of a flexible material, which can be placed in  
abutment with a windscreen to be wiped, which wiper blade  
includes opposing longitudinal grooves on its  
longitudinal sides, in which grooves spaced-apart  
longitudinal strips of the carrier element are disposed,  
10 wherein neighbouring ends of said longitudinal strips are  
interconnected by a respective connecting piece, which  
windscreen wiper device comprises a connecting device for  
an oscillating arm, wherein said oscillating arm is  
pivotally connected to said connecting device about a  
15 pivot axis near one end, **characterized in that** said  
connecting device comprises at least two parts provided  
with protrusion/hole means for detachably connecting said  
parts together, wherein the first part is retained onto  
the wiper blade and wherein the second part has an at  
20 least substantially U-shaped cross-section at the  
location of its connection to said first part, wherein  
each leg of said U-shaped cross-section is allowed to  
bend outwardly upon insertion of the oscillating arm into  
said second part for connecting said first and second  
25 parts together through a snapping operation.
  
2. A windscreen wiper device according to claim 1, wherein  
each leg of said U-shaped cross-section is bendable  
between a first position, wherein said first and second  
30 parts are connected together through a snapping operation  
upon insertion of the oscillating arm into said second  
part, and a second position, wherein said first and

second parts are released from each other upon removing the oscillating arm from said second part.

3. A windscreen wiper device according to claim 1 or 2,  
5 wherein said first part is provided with opposite abutting surfaces for abutting against the legs of the U-shaped cross-section, and wherein a protrusion extends laterally outwardly from each leg of the U-shaped cross-section into a hole provided on an abutting surface  
10 abutting against a respective leg.
4. A windscreen wiper device according to claim 1 or 2,  
wherein said first part is provided with opposite abutting surfaces for abutting against the legs of the U-  
15 shaped cross-section, and wherein a protrusion extends laterally inwardly from each abutting surface into a hole provided on a leg abutting against a respective abutting surface.
- 20 5. A windscreen wiper device according to any of the preceding claims 1 through 4, wherein the second part is positioned at least substantially within said first part.
6. A windscreen wiper device according to any of the  
25 preceding claims 1 through 5, wherein said first part comprises engaging members made integral therewith for engaging around the longitudinal sides of the longitudinal strips that face away from each other.
- 30 7. A windscreen wiper device according to any of the preceding claims 1 through 6, wherein said second part comprises at least one resilient tongue engaging in a correspondingly shaped hole provided in the oscillating

arm, and wherein said resilient tongue is rotatable along a hinge axis between an outward position retaining the wiper blade onto the oscillating arm and an inward position releasing the wiper blade from the oscillating arm.

5

8. A windscreen wiper device according to claim 7, wherein said resilient tongue is forced in the outward position under the influence of a moment in case a force is exerted on the wiper blade in a direction away from the oscillating arm.

10

9. A windscreen wiper device according to claim 8, wherein a counterforce exerted by the oscillating arm on the resilient tongue engages at a point located behind the hinge axis, seen in the direction of the force exerted on the wiper blade.

15

10 A windscreen wiper blade according to claim 7, 8 or 9, wherein the hinge axis is located near an outer edge of said second part.

20

11 A windscreen wiper device according to any of the preceding claims 7 through 10, wherein said hole has a closed circumference.

25

12 A windscreen wiper device according to any of the preceding claims 1 through 11, wherein said windscreen wiper device is provided with first and second retaining means for retaining said connecting device onto said oscillating arm, wherein said first retaining means comprises said at least one resilient tongue engaging in said correspondingly shaped hole, and wherein said second

30

retaining means comprise at least one protrusion provided on the first part engaging the oscillating arm.

13 A windscreen wiper device according claim 12, wherein  
5 said protrusion engages into a correspondingly shaped hole with a closed circumference provided on the oscillating arm.

14 A windscreen wiper device according claim 12, wherein  
10 said protrusion engages into a correspondingly shaped hole with an open circumference provided on a longitudinal side of the oscillating arm.

15 A windscreen wiper device according claim 12, wherein  
15 said protrusion engages into a correspondingly shaped recess provided on the oscillating arm.

20

25

30

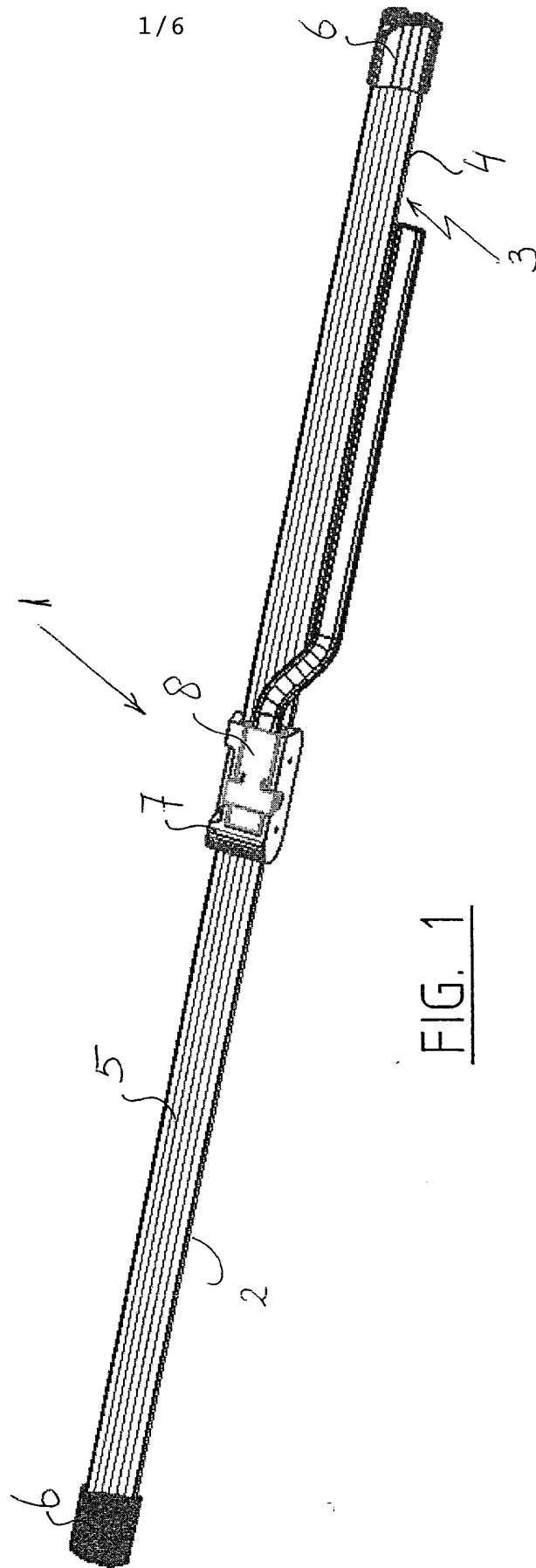

FIG. 1

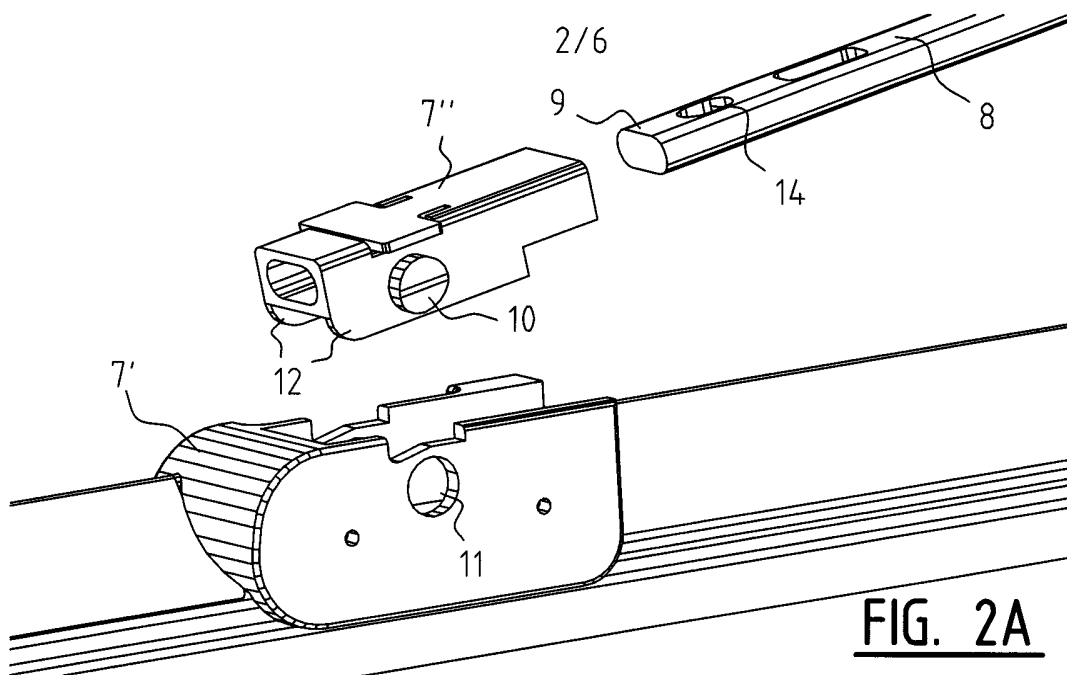

FIG. 2A

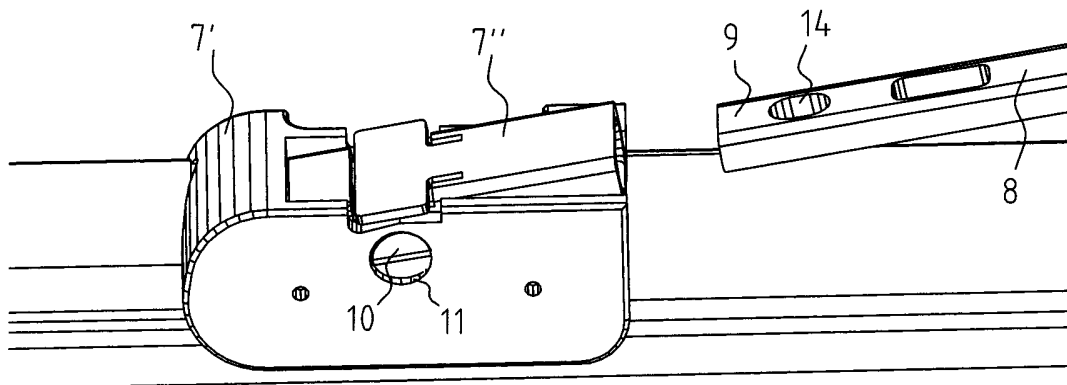

FIG. 2B

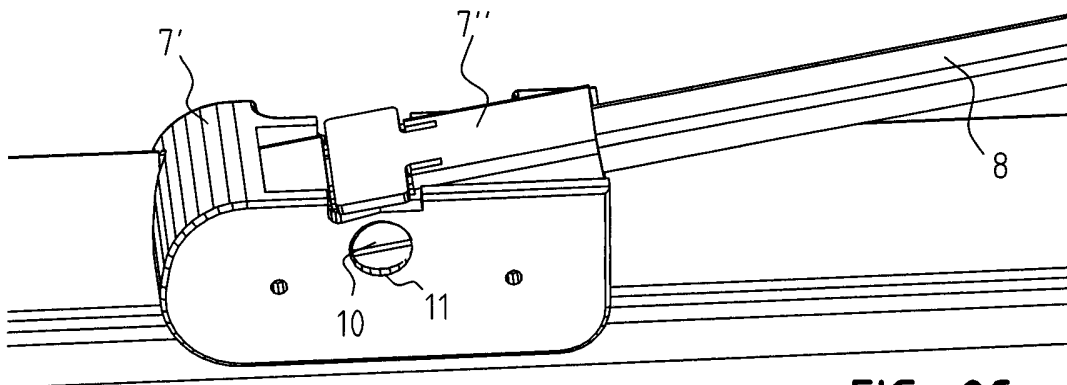
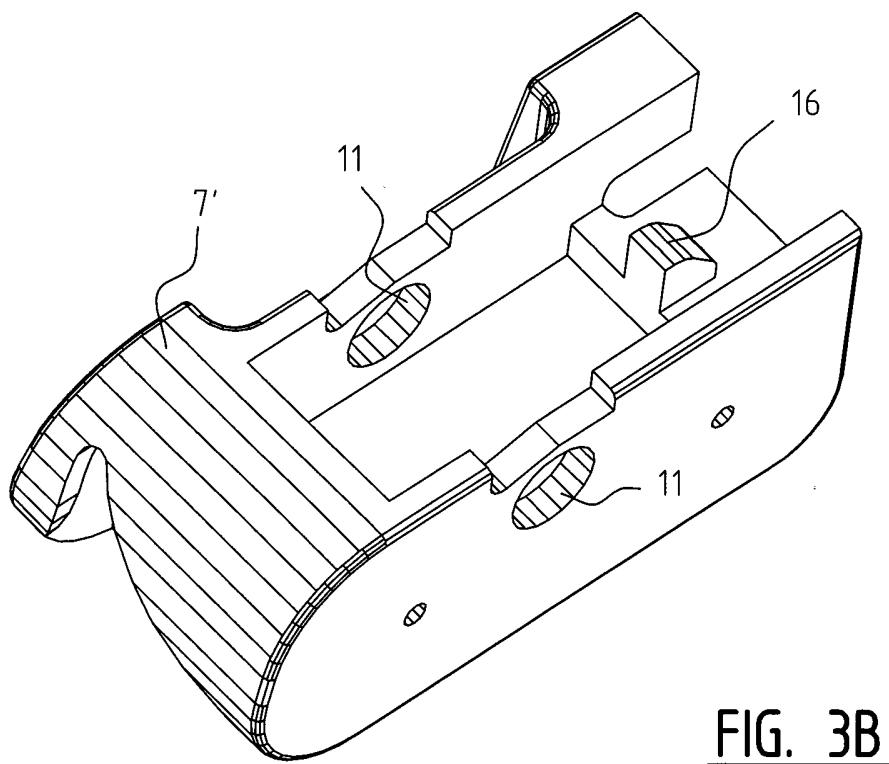
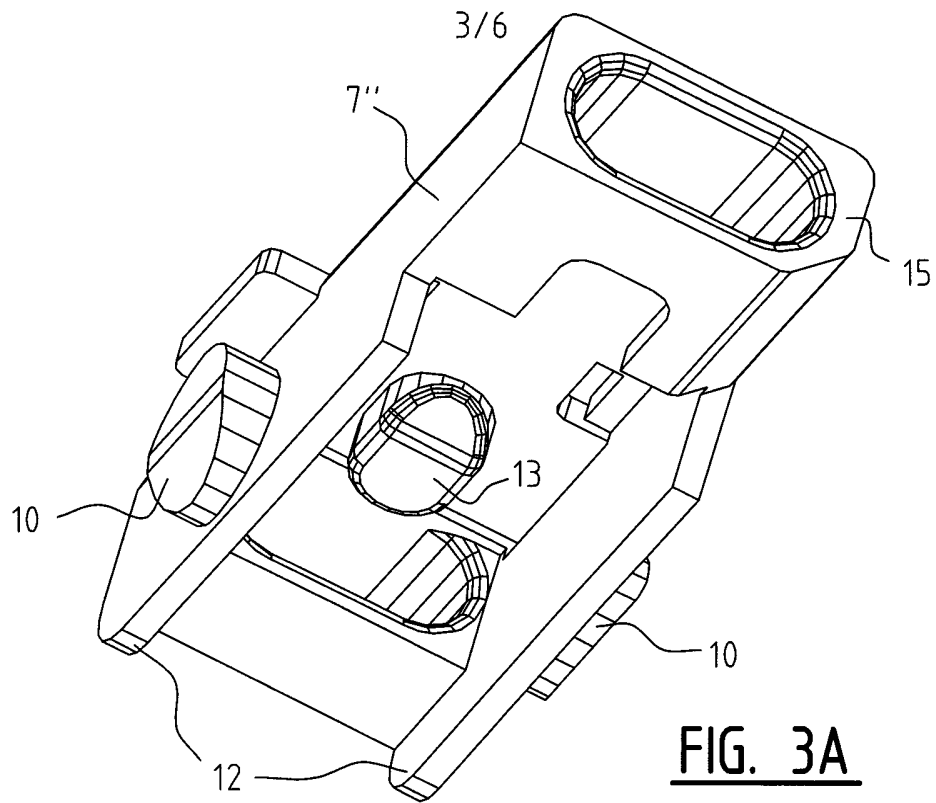

FIG. 2C





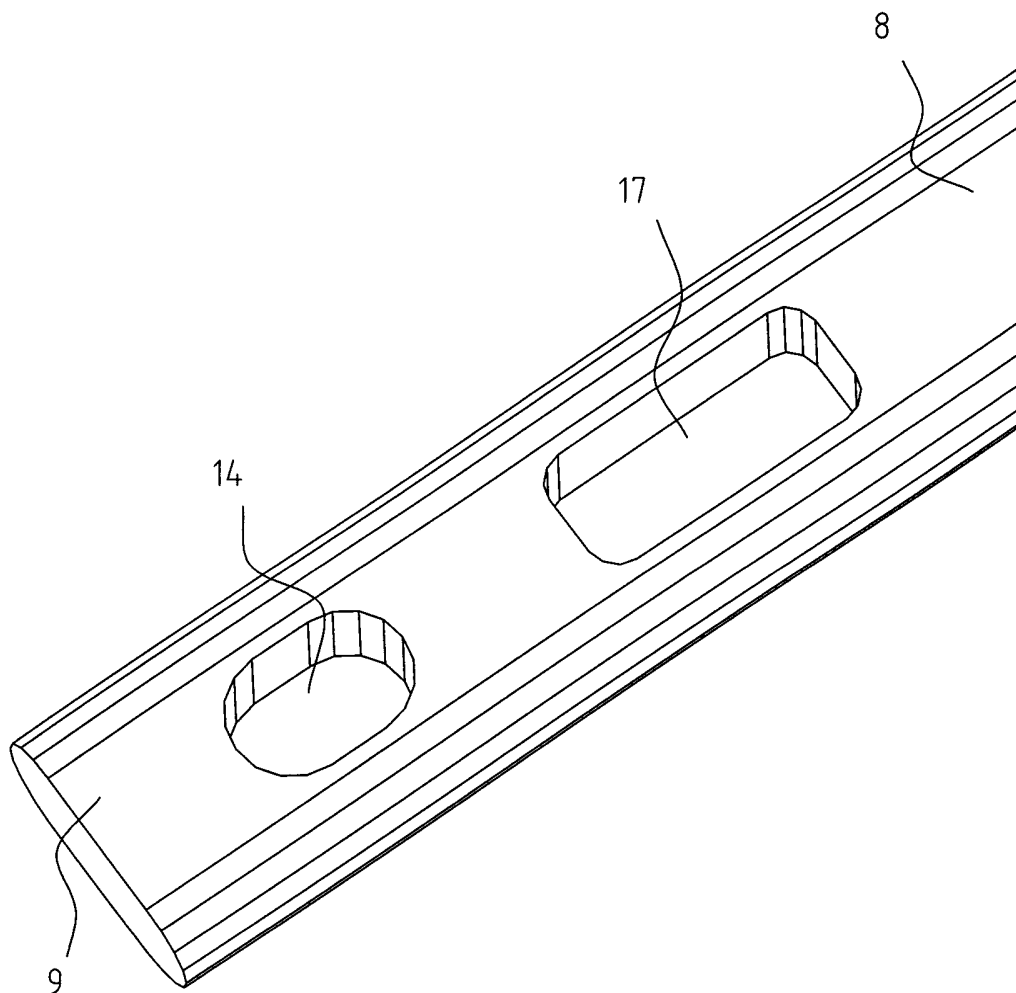

FIG. 4

5/6

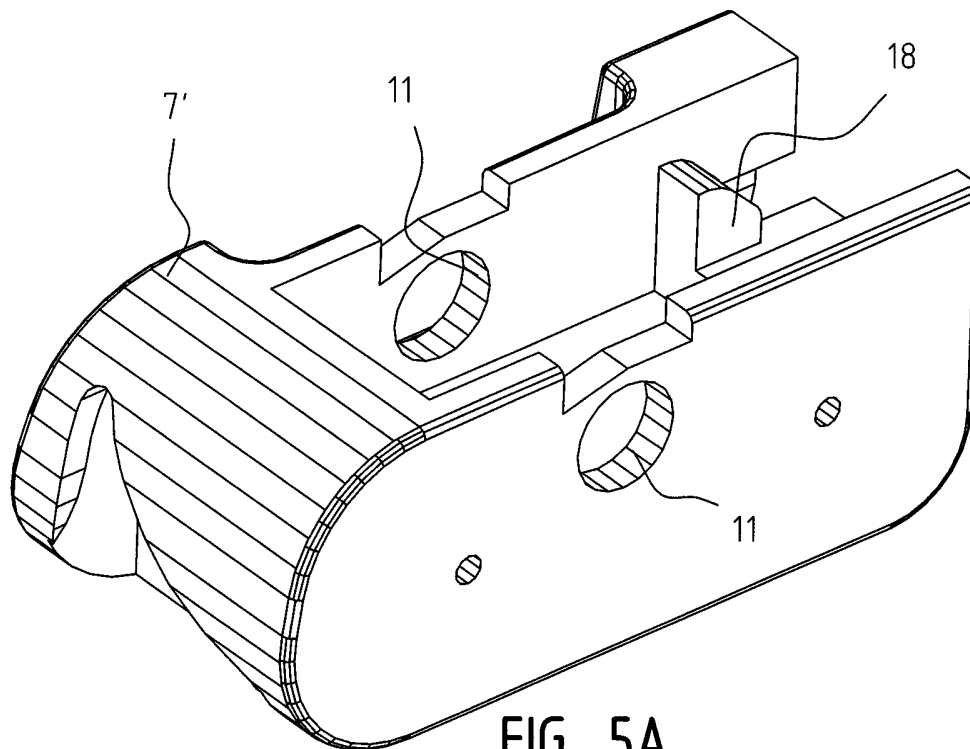

FIG. 5A

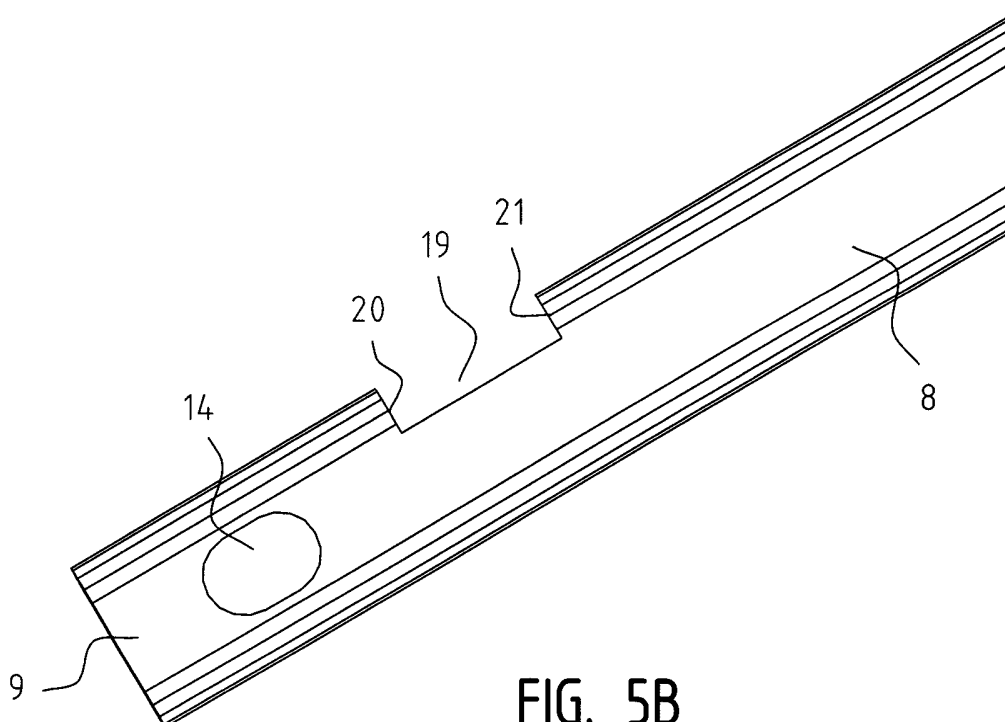

FIG. 5B

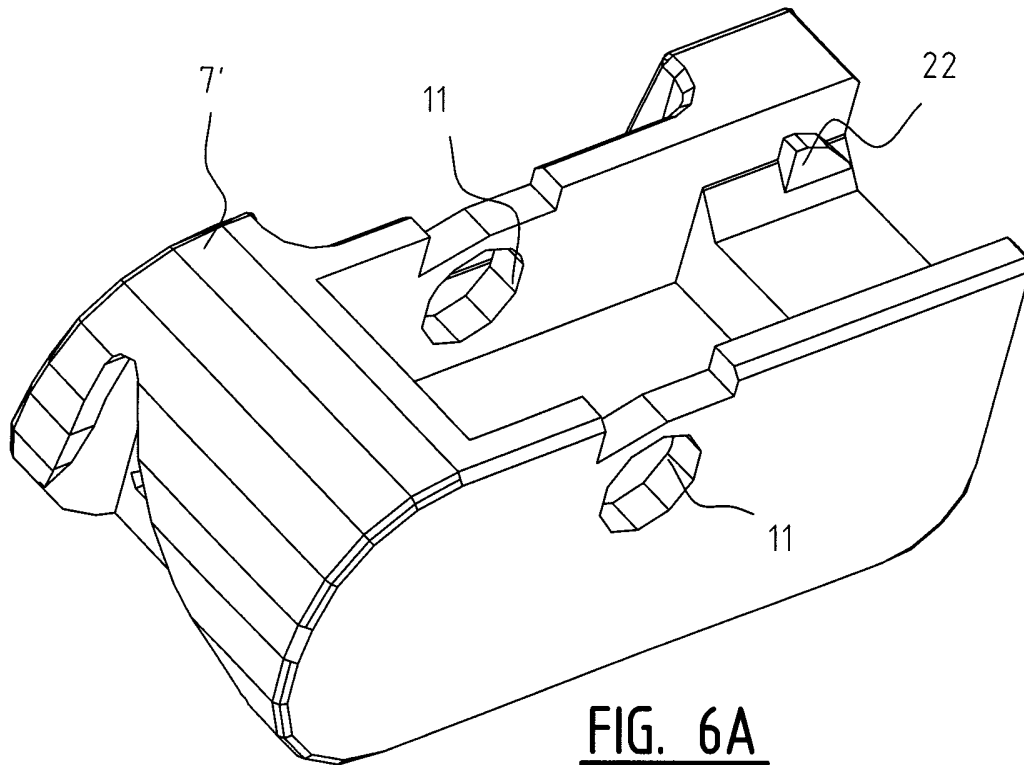

FIG. 6A

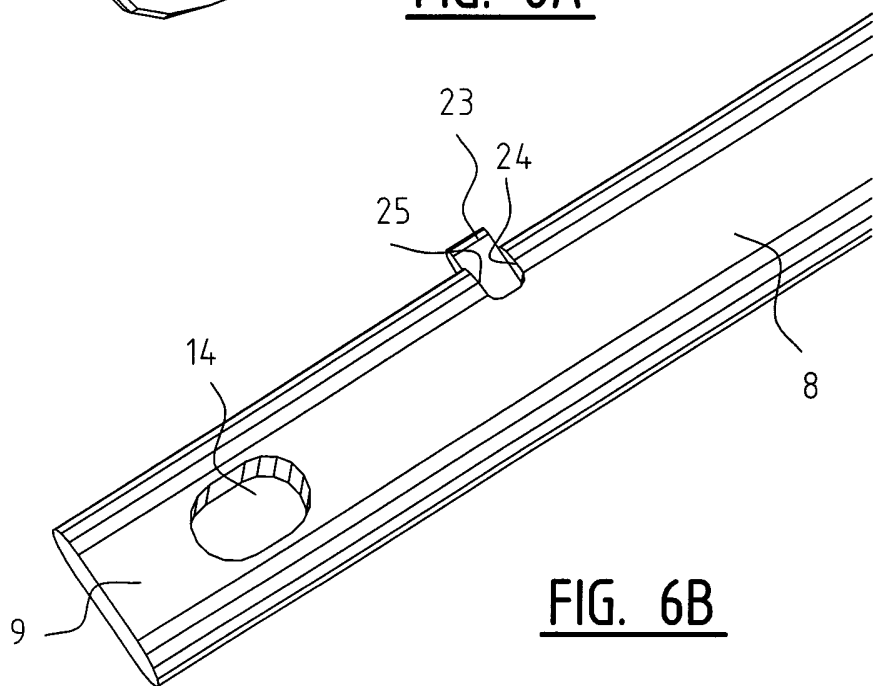

FIG. 6B

**INTERNATIONAL SEARCH REPORT**

International application No  
PCT/EP2006/050119

**A. CLASSIFICATION OF SUBJECT MATTER**  
INV. B60S1/40

According to International Patent Classification (IPC) or to both national classification and IPC

**B. FIELDS SEARCHED**  
Minimum documentation searched (classification system followed by classification symbols)  
B60S

Documentation searched other than minimum documentation to the extent that such documents are included in the fields searched

Electronic data base consulted during the international search (name of data base and, where practical, search terms used)  
EPO-Internal, PAJ

**C. DOCUMENTS CONSIDERED TO BE RELEVANT**

Category*	Citation of document, with indication, where appropriate, of the relevant passages	Relevant to claim No.
A	EP 1 403 156 A (FEDERAL-MOGUL S.A) 31 March 2004 (2004-03-31) figures 1,2a-2c paragraph [0014] - paragraph [0016]	1
A	WO 2004/024520 A (VALEO SYSTEMES D'ESSUYAGE; VACHER, PASCAL) 25 March 2004 (2004-03-25) figures	1

Further documents are listed in the continuation of Box C.

See patent family annex.

\* Special categories of cited documents :

- \*A\* document defining the general state of the art which is not considered to be of particular relevance
- \*E\* earlier document but published on or after the international filing date
- \*L\* document which may throw doubts on priority claim(s) or which is cited to establish the publication date of another citation or other special reason (as specified)
- \*O\* document referring to an oral disclosure, use, exhibition or other means
- \*P\* document published prior to the international filing date but later than the priority date claimed

- \*T\* later document published after the international filing date or priority date and not in conflict with the application but cited to understand the principle or theory underlying the invention
- \*X\* document of particular relevance; the claimed invention cannot be considered novel or cannot be considered to involve an inventive step when the document is taken alone
- \*Y\* document of particular relevance; the claimed invention cannot be considered to involve an inventive step when the document is combined with one or more other such documents, such combination being obvious to a person skilled in the art.
- \* & \* document member of the same patent family

Date of the actual completion of the international search  5 April 2006	Date of mailing of the international search report  12/04/2006
Name and mailing address of the ISA/ European Patent Office, P.B. 5818 Patentlaan 2 NL - 2280 HV Rijswijk Tel. (+31-70) 340-2040, Tx. 31 651 epo nl, Fax: (+31-70) 340-3016	Authorized officer  Westland, P

# INTERNATIONAL SEARCH REPORT

Information on patent family members

International application No PCT/EP2006/050119
---

Patent document cited in search report	A	Publication date		Patent family member(s)	Publication date
EP 1403156	A	31-03-2004	AU	2003299093 A1	19-04-2004
			CA	2499044 A1	08-04-2004
			WO	2004028875 A1	08-04-2004
			JP	2006500273 T	05-01-2006
WO 2004024520	A	25-03-2004	AU	2003264325 A1	30-04-2004
			BR	0314150 A	12-07-2005
			CN	1681691 A	12-10-2005
			EP	1545947 A1	29-06-2005
			FR	2844492 A1	19-03-2004
			JP	2005537978 T	15-12-2005
			MX	PA05002760 A	03-06-2005
			US	2006010636 A1	19-01-2006