

**(12) STANDARD PATENT**  
**(19) AUSTRALIAN PATENT OFFICE**

(11) Application No. **AU 2009257429 B2**

(54) Title  
**Shielding assemblies for infusion systems**

(51) International Patent Classification(s)  
**A61M 5/14** (2006.01) **G21F 5/015** (2006.01)  
**A61M 36/00** (2006.01)

(21) Application No: **2009257429** (22) Date of Filing: **2009.06.11**

(87) WIPO No: **WO09/152320**

(30) Priority Data

(31) Number	(32) Date	(33) Country
<b>12/137,356</b>	<b>2008.06.11</b>	<b>US</b>
<b>12/137,364</b>	<b>2008.06.11</b>	<b>US</b>
<b>12/137,377</b>	<b>2008.06.11</b>	<b>US</b>
<b>12/137,363</b>	<b>2008.06.11</b>	<b>US</b>

(43) Publication Date: **2009.12.17**

(44) Accepted Journal Date: **2015.03.19**

(71) Applicant(s)  
**BRACCO DIAGNOSTICS INC.**

(72) Inventor(s)  
**Lokhande, Vishal N.;Quirico, Charles R.;Clements, Daniel V.;Childs, Jacob S.;Krause, Eric J.;Darst, Daniel D.;Madson, Peter B.;Balestracci, Ernest**

(74) Agent / Attorney  
**Griffith Hack, GPO Box 4164, Sydney, NSW, 2001**

(56) Related Art  
**WO 2005/002971 A1**  
**WO 2008/082966 A2**





**(84) Designated States** (unless otherwise indicated, for every kind of regional protection available): ARIPO (BW, GH, GM, KE, LS, MW, MZ, NA, SD, SL, SZ, TZ, UG, ZM, ZW), Eurasian (AM, AZ, BY, KG, KZ, MD, RU, TJ, TM), European (AT, BE, BG, CH, CY, CZ, DE, DK, EE, ES, FI, FR, GB, GR, HR, HU, IE, IS, IT, LT, LU, LV, MC, MK, MT, NL, NO, PL, PT, RO, SF, SI, SK, TR), OAPI (BF, BJ, CF, CG, CI, CM, GA, GN, GQ, GW, ML, MR, NE, SN, TD, TG).

**Published:**

- with international search report (Art. 21(3))
- before the expiration of the time limit for amending the claims and to be republished in the event of receipt of amendments (Rule 48.2(h))

**(88) Date of publication of the international search report:**

8 April 2010

## SHIELDING ASSEMBLIES FOR INFUSION SYSTEMS

## RELATED APPLICATIONS

5 The present application claims priority to the following U.S. patent applications: U.S. Patent Application No. 12/137,356, filed June 11, 2008; U.S. Patent Application No. 12/137,363, filed June 11, 2008; U.S. Patent Application No. 12/137,364, filed June 11, 2008; and U.S. Patent Application No. 12/137,377, filed June 11, 2008.

## 10 TECHNICAL FIELD

The present invention pertains to systems that generate and infuse radiopharmaceuticals, and, more particularly, to shielding assemblies thereof.

## BACKGROUND

15 Nuclear medicine employs radioactive material for therapy and diagnostic imaging. Positron emission tomography (PET) is one type of diagnostic imaging, which utilizes doses of radiopharmaceutical, for example, generated by elution within a radioisotope generator that are injected, or infused into a patient. The infused dose of radiopharmaceutical is absorbed by cells of a target organ, of the patient, and emits  
20 radiation, which is detected by a PET scanner, in order to generate an image of the organ. An example of a radioactive isotope, which may be used for PET, is Rubidium-82 (produced by the decay of Strontium-82); and an example of a radioisotope generator, which yields a saline solution of Rubidium-82, via elution, is the CardioGen-82® available from Bracco Diagnostics Inc. (Princeton, NJ).

25 Whether the half-life of a particular radioactive isotope, employed by a radiopharmaceutical, is relatively short or long, a patient undergoing a nuclear imaging procedure is not typically exposed to a significant amount of radiation. However those personnel, whose job it is to set up and maintain radiopharmaceutical infusion systems, and to administer doses therefrom, are subject to more frequent exposures to radiation.  
30 Therefore, shielding assemblies, which provide a radiation barrier to protect these personnel from excessive exposure to radiation sources, are an important component of radiopharmaceutical generators and infusion systems. These shielding assemblies are typically formed with lead sidewalls, the bulk and weight of which can pose

difficulties for the personnel who regularly set up, maintain and use the systems.

Thus, there is a need for improved shielding assemblies employed by systems that generate and infuse radiopharmaceuticals.

5 SUMMARY OF THE INVENTION

In accordance with a first aspect of the present invention, there is provided a shielding assembly for a system that generates and infuses radiopharmaceuticals, the shielding assembly comprising:

10 a first compartment sized to contain one or more radioisotope generators of the system, the first compartment being enclosed by a first sidewall that forms a barrier to radioactive radiation, the first sidewall including an opening extending through the first sidewall, the opening being oriented upward and located at a first elevation with respect to ground level;

15 a second compartment sized to contain a portion of an infusion circuit of the system that is downstream of the one or more generators, the second compartment being enclosed by a second sidewall that forms a barrier to radioactive radiation, the portion of the infusion circuit including an eluate tubing line, a patient line, and a waste line, the patient line and the waste line both being coupled to the eluate tubing line;

20 a third compartment sized to contain a waste bottle of the system, the third compartment being enclosed by a third sidewall that forms a barrier to radioactive radiation, the third sidewall including an opening, extending through the third sidewall, the opening of the third sidewall being oriented upward and located at a second elevation, with respect to ground level, and the second elevation being greater than the first elevation of the opening of the first sidewall;

25 a first door mating with the opening of the first sidewall to alternately enclose the first compartment and provide access to the first compartment;

a second door mating with the opening of the second sidewall to alternately enclose the second compartment and provide access to the second compartment; and

a third door mating with the opening of the third sidewall to alternately enclose the third compartment and provide access to the third compartment,

30 wherein the first door defines a first door edge, the second door defines a second door edge, and the second door edge overlaps the first door edge so as to prevent the first door from being opened if the second door is not open.

35 In accordance with a first aspect of the present invention, there is provided a method for setting up an infusion system, the method comprising:

opening a first door of a shielding assembly of the infusion system to access a first compartment of the assembly and to allow for a second door of the shielding assembly to be opened, wherein the first door defines a first door edge, the second door defines a second door

edge, and the first door edge overlaps the second door edge so as to prevent the second door from being opened if the first door is not open; and

opening the second door, after opening the first door, to access a second compartment of the shielding assembly, the second compartment being separate from, and outside of, the first compartment;

placing a radioisotope generator into the second compartment and connecting the generator to an infusion tubing circuit;

placing a portion of the infusion tubing circuit into the first compartment;

closing the second door to enclose the generator within the second compartment; and

closing the first door, after closing the second door, to enclose the portion of the infusion tubing circuit within the first compartment.

In accordance with a first aspect of the present invention, there is provided a shielding assembly for a system that generates and infuses radiopharmaceuticals, the shielding assembly comprising a first compartment and a second compartment, the first compartment being enclosed by a first sidewall of the shielding assembly and the second compartment being enclosed by a second sidewall of the shielding assembly, each of the first and second sidewalls providing a radioactive radiation barrier for the corresponding compartment and each including a door;

a first of the doors to alternately enclose and provide access to the first compartment; and a second of the doors to alternately enclose and provide access to the second compartment; and the shielding assembly being characterized in that:

the first compartment is sized to contain one or more radioisotope generators of the system;

the second compartment is separate from, and outside of, the first compartment, being located adjacent thereto, and is sized to contain a portion of an infusion circuit of the system that is downstream of the one or more generators; and the second door is configured such that, when the second door encloses the second compartment, the second door prevents the first door from opening to provide access to the first compartment wherein the first door defines a first door edge, the second door defines a second door edge, and the second door edge overlaps the first door edge so as to prevent the first door from being opened if the second door is not open.

In accordance with a first aspect of the present invention, there is provided a system that generates and infuses radiopharmaceuticals, the system comprising a cabinet structure and , the shielding assembly of any one of Claims 1 to 8, the cabinet structure including a shell that defines an interior space in which the shielding assembly is mounted, and wherein the shell of the cabinet structure includes a first upper opening and an upper surface; and the upper

surface of the shell is located above, the first upper opening of the shell, the first upper opening being aligned with the first door and the opening of the first sidewall of the shielding assembly, in order to provide access thereto.

5

#### BRIEF DESCRIPTION OF THE DRAWINGS

The following drawings are illustrative of particular embodiments of the present invention and therefore do not limit the scope of the invention. The drawings are not to scale (unless so stated) and are intended for use in conjunction with the explanations in the following detailed description. Embodiments of the present invention will hereinafter be described in conjunction with the appended drawings, wherein like numerals denote like elements.

10

Figure 1A is a first perspective view of an infusion system, according to some embodiments of the present invention.

15

Figure 1B is another perspective view of a portion of a cabinet structure of the system shown in Figure 1A, according to some embodiments.

Figure 1C is a second perspective view of the system shown in Figure 1A, according to some embodiments.

20

Figure 1D is a schematic of an infusion circuit, according to some embodiments of the present invention.

Figure 1E is a perspective view of exemplary sample vial shielding that may be employed in conjunction with the infusion system of Figure 1A.

Figure 2A is a perspective view of a shielding assembly for an infusion system, such as that shown in Figures 1A-C, according to some embodiments of the present invention.

25

Figure 2B is a perspective view of a framework of the system, according to some embodiments, with an enlarged detailed view of a component of the system, according to some embodiments.

Figure 3A is another perspective view of the shielding assembly shown in Figure 2A.

30

Figure 3B is a perspective view of the infusion circuit, shown in Figure 1C, configured and routed, according to some embodiments.

Figure 3C is a perspective view of a disposable infusion circuit subassembly, according to some embodiments.

Figure 3D is a frame for the subassembly shown in Figure 3C, according to some embodiments.

Figure 4 is a main menu screen shot from an interface of a computer, which may be included in systems of the present invention, according to some embodiments.

5           Figure 5A is a schematic showing a first group of successive screen shots from the computer interface, according to some embodiments.

Figure 5B is a pair of screen shots from the computer interface, which provide indications related to eluant volume levels in a reservoir of the system, according to some embodiments.

10           Figure 5C is a schematic showing a second group of successive screen shots from the computer interface, according to some embodiments.

Figure 6 is a schematic showing a third group of successive screen shots from the computer interface, according to some embodiments.

15           Figures 7A-C are schematics showing a fourth group of successive screen shots from the computer interface, according to some embodiments.

Figures 8A-B are schematics showing a fifth group of successive screen shots from the computer interface, according to some embodiments.

Figures 9A-C are schematics showing a sixth group of successive screen shots from the computer interface, according to some embodiments.

20           Figure 10 is a schematic showing a seventh group of successive screen shots from the computer interface, according to some embodiments.

Figure 11 is an exemplary report which may be generated by the computer included in infusion systems, according to some embodiments.

25           Figures 12A-B are schematics of alternative infusion circuits that may be employed by embodiments of the present invention.

Figure 12C is a schematic illustrating exemplary activity profiles of injected doses of a radiopharmaceutical.

#### DETAILED DESCRIPTION

30           The following detailed description is exemplary in nature and is not intended to limit the scope, applicability, or configuration of the invention in any way. Rather, the following description provides practical illustrations for implementing exemplary



embodiments. Utilizing the teaching provided herein, those skilled in the art will recognize that many of the examples have suitable alternatives that can be utilized.

Figure 1A is a first perspective view of an infusion system 10, according to some embodiments of the present invention, wherein system 10 is shown supported by a cabinet structure, which includes a platform 113 (seen better in Figure 2B) and a shell 13; shell 13 extends upward from a skirt 11, that surrounds platform 113, to surrounds an interior space in which a portion of infusion system 10 is contained (- seen in Figure 1C). Shell may be formed from panels of injection-molded polyurethane fitted together according to methods known to those skilled in the art. Figure 1A illustrates the cabinet structure of system 10 including a grip or handle 14, which extends laterally from shell 13, in proximity to an upper surface 131 thereof, and a post 142, which extends upward from shell 13, and to which a work surface, or tray 16 and a computer 17 are, preferably, attached, via an ergonomic, positionable mount. According to some embodiments, computer 17 is coupled to a controller of system 10, which is mounted within the interior space surrounded by shell 13; and, a monitor 172 of computer 17 not only displays indications of system operation for a user of system 10, but also serves as a device for user input (e.g. touch screen input). However, according to alternate embodiments, another type of user input device, known to those skilled in the art, may be employed by computer 17. Other types of user input devices may be included, for example, a keyboard, a series of control buttons or levers, a bar code reader (or other reader of encoded information), a scanner, a computer readable medium containing pertinent data, etc. The user input device may be mounted on the cabinet structure of system 10, as shown, or may be tethered thereto; alternatively the user input device may be remote from system 10, for example, located in a separate control room. According to some additional embodiments, another user input device, for example, in addition to a touch screen of computer 17, may be remote from system 10 and used to start and stop infusions, as well as to monitor system operation both during quality control infusions and during patient infusions. Operation of system 10, which is facilitated by computer 17, will be described below, in conjunction with Figures 4-9C.

Figure 1A further illustrates two pairs of wheels 121, 122, mounted to an underside of platform 113, to make system 10 mobile; handle 14 is shown located at an elevation suitable for a person to grasp in order to maneuver system 10, from one

location for another, upon pairs of wheels 121, 122. According to some preferred embodiments, one or both pairs of wheels 121, 122, are casters, allowing for rotation in a horizontal plane (swivel), in order to provide additional flexibility for maneuvering system 10 in relatively tight spaces.

5           Figure 1B is a perspective view of a portion of system 10, on a side 111 of the cabinet structure, which is in proximity to wheels 121. Figure 1B illustrates a lever or pedal 125, which is located for activation by a foot of the person, who grasps handle 14 to maneuver system 10. In a neutral position, pedal 125 allows wheels 121, 122 to rotate, and, if embodied as casters, to swivel freely. Pedal 125 may be depressed to a  
10           first position which prevents a swiveling of wheels 122, according to those embodiments in which wheels 122 are casters, and may be further depressed to brake wheels 121, 122 from rolling and swiveling, upon reaching a desired location. According to some embodiments, braking may be designed to slow system 10, for example, when rolling down an incline, and, according to yet further embodiments,  
15           system 10 may include a motor to power movement thereof.

          Figure 1B further illustrates: a rear access panel 174 of shell 13, for example, providing access to circuit boards of the aforementioned controller contained within the interior space that is surrounded by shell 13; an optional lock 184, to secure panel 174; a power jack 118, for connecting system 10 to a power source; and a printer 117  
20           for providing documentation of each patient infusion carried out by system 10, and of system quality control test results. In some embodiments, system 10 may further include a power strip by which auxiliary equipment may be powered, and one or more additional electrical connectors, or ports (not shown), which are supported by platform 113 and may be integrated into shell 13, for example, in proximity to jack  
25           118 or printer 117; these electrical connectors/ports allow system 10 to communicate with, other devices used for nuclear imaging procedures, for example, a PET scanner/camera, and/or for coupling to an intranet network, and/or to the internet, for example, to link up with software programs for various types of data analysis, and/or to link to computers of consulting clinicians/physicians, and/or to link into service  
30           providers and/or component suppliers data bases for enhanced maintenance and inventory management.

          Figure 1A further illustrates upper surface 131 of shell 13 including several openings 133, 135, 139 formed therein. Figure 1C is a partially exploded perspective

view of system 10, wherein a removable access panel 132 is shown as a contoured portion of upper surface 131, which, when exposed, by lifting away a bin 18, that mates therewith, may be removed from another opening 137 formed in upper surface 131. Figure 1C also provides a better view of another panel 134 which may be lifted  
5 away from opening 139. According to the illustrated embodiment, openings 139 and 137 provide a user of system 10 with independent access to separate portions of infusion system 10, which are contained within shell 13, for example, to set up and maintain system 10; and openings 133 and 135 provide passageways for tubing lines to pass through shell 13. Figure 1C further illustrates an optional switch 102, which in  
10 case of an emergency, may be activated to abort function of system 10. With reference to Figures 1A and 1C, it may be appreciated that an arrangement of features formed in upper surface 131 of shell 13, in conjunction with bin 18, tray 16 and computer 17, provide a relatively ergonomic and organized work area for technical personnel who operate system 10.

Turning now to Figure 1D, a schematic of an infusion circuit 300, which may be incorporated by system 10, is shown. Figure 1D illustrates circuit 300 generally divided into a first part 300A, which includes components mounted outside shell 13, and a second part 300B, which includes components mounted within the interior space surrounded by shell 13. (Parts 300A and 300B are delineated by dotted lines in Figure  
15 1D.) Figure 1D further illustrates second part 300B of circuit 300 including a portion contained within a shielding assembly 200, which is designated schematically as a dashed line. Some embodiments of shielding assembly 200 will be described in greater detail, in conjunction with Figures 2A-B and 3A-B, below.

According to the illustrated embodiment, circuit 300 includes: an eluant  
25 reservoir 15, for example, a bag, bottle or other container, containing saline as the eluant, which is shown hanging from a post, or hanger 141 above upper surface 131 of shell 13 in Figure 1A; a syringe pump 33, for pumping the eluant from reservoir 15, and a pressure syringe 34 (or other device or sensor), for monitoring pumping pressure; a filter 37, which may also serve as a bubble trap, for the pumped eluant; a  
30 radioisotope generator 21, through which the filtered eluant is pumped to create a radioactive eluate, for example an eluate carrying Rubidium-82 that is generated by the decay of Strontium-82, via elution, within a column of generator 21; and an activity detector 25, for measuring the activity of the eluate discharged from generator 21, in

order to provide feedback for directing the flow of the eluate, via a divergence valve 35WP, either to a waste bottle 23 or through a patient line 305p, for example, to inject a dose of the radiopharmaceutical eluate into a patient. With reference back to Figure 1A, patient line 305p is shown extending out from shell 13, through opening 135, to a distal end thereof, which, according to some embodiments, includes a filter. Patient line 305p may be coupled to another line that includes a patient injection needle (not shown). Alternatively, patient line 305p may be coupled to another line (not shown), which extends from a source of another active substance, for example, a stress agent; the other line is coupled to the line that includes the patient injection needle, in order to permit injection of the additional active substance.

Figure 1D illustrates an eluant tubing line 301 coupled to reservoir 15 and to pump 33, and, with reference to Figures 1A-B, it may be appreciated that opening 133 provides the passageway for tubing line 301 to enter the interior space surrounded by shell 13. According to some preferred embodiments, opening 133 includes a grommet-type seal that prevents leakage of eluant, which may spill from reservoir 15, into the interior space through opening 133, while allowing a user to assemble tubing line 301 through opening 133. Likewise opening 135, which provides a passageway for patient line 305p, may include a grommet-type seal. According to some embodiments, shell 13 further supports holders to safely hold, for example, during transport of system 10, portions of tubing lines that extend outward therefrom, for example, line 301 and/or line 305p.

Figure 1D further illustrates another eluant tubing line 302 coupled to pump 33 and a divergence valve 35BG, which may either direct pumped eluant through a tubing line 304, to generator 21, or direct the pumped eluant through a by-pass tubing line 303, directly to patient line 305p. Divergence valve 35BG, as well as divergence valve 35WP, which directs eluate from an eluate tubing line 305 either to a waste line 305w or to patient line 305p, may each be automatically operated by a corresponding servomotor (not shown), coupled to the controller (not shown) of system 10, which controller receives feedback from activity detector 25. When system 10 is operating for automatic infusion, to deliver a dose of radiopharmaceutical to a patient, for example, Rubidium-82 for diagnostic imaging, divergence valve 35BG is initially set to direct eluant to generator 21 and divergence valve 35WP is set to direct eluate from generator into waste bottle 23, until activity detector 25 detects the desired activity of

the eluate, at which time the feedback from activity detector 25 causes the controller to direct the corresponding servo-motor to re-set valve 35WP for diverting the flow of eluate into patient line 305p. According to some embodiments, once a prescribed volume of the eluate has passed through patient line 305p, the controller directs the corresponding servomotor to re-set divergence valve 35BG for diverting the flow of eluant through by-pass line 303 and into patient line 305p in order to flush, or push any eluate remaining in patient line 305p into the patient. According to some embodiments, the controller may also direct the corresponding servomotor to re-set divergence valve 35WP back toward waste bottle 23, prior to the flush through by-pass line 303, in order to prevent back flow of eluant, through line 305, toward generator 21. According to some preferred methods of operation, in certain situations, which will be described in greater detail below, eluant is pumped through by-pass line 303 immediately following the flow of the prescribed volume of eluate into patient line 305p, at a higher speed, in order to push the eluate in patient line 305, thereby increasing a flow rate of the injection of eluate out from patient line 305p and into patient. For example, once the prescribed volume of eluate has flowed into patient line 305p, and once divergence valve 35BG is set to divert flow through by-pass line 303, the speed of pump 33 may be adjusted to increase the flow rate of eluant to between approximately 70mL/min and approximately 100mL/min. This method for increasing the injection flow rate, is desirable, if a relatively high flow rate is desired for patient injection and a flow rate through generator 21 is limited, for example, to below approximately 70mL/min, maximum (typical flow rate may be approximately 50mL/min), in order to avoid an excessive back pressure created by the column of generator 21 in upstream portions of tubing circuit 300; the excessive back pressure could damage filter 37 or otherwise impede flow through eluant tubing line 302.

Although not shown in Figure 1D, a number of sensors, for example, to measure pressure and/or flow velocity, may be incorporated into circuit 300, according to some alternate embodiments, in order to monitor for flow anomalies, for example, related to occlusions/plugs in circuit 300 and/or leaks, and/or to provide feedback for control of an activity level of infused doses of radiopharmaceutical. Suitable sensors for any of the above purposes are known to those skilled in the art. Examples of flow meters that may be incorporated into circuit 300, include the Innova-Sonic® Model 205 Transit-Time Ultrasonic Liquid Flow Meter that employs digital signal processing

(available from Sierra Instruments, Inc.) and the Flocat LA10-C differential pressure flow meter. One example of a pressure sensor that may be employed to detect infusion circuit occlusions is the PRO / Pressure-Occlusion Detector (available from INTROTEK® of Edgewood, NY, a subsidiary of Magnetrol of Downers Grove, IL),  
5 which employs pulse-type ultrasound; this sensor detects subtle changes in positive and negative air pressure and produces a corresponding passive resistive output signal, which may be routed to the system controller and/or computer 17. On or more of this type of sensor may be incorporated into infusion circuit 300 by simply fitting the sensor around any of the tubing lines of infusion circuit 300; in fact, the PRO /  
10 Pressure-Occlusion Detector may be a suitable alternative to pressure syringe 34 of circuit 300. Other types of pressure sensors, for example, similar to those known in the art for blood pressure monitoring, may be employed in infusion circuit 300.

System 10 may further include sensors to detect fluid levels in eluant reservoir 15 and waste bottle 23. Some examples of such sensors, which also employ the  
15 aforementioned pulse-type ultrasound, are the Drip Chamber Liquid Level Sensor and the CLD / Continuous Level Detector (both available from INTROTEK®); alternatively, for example, an HPQ-T pipe mounted, self-contained liquid sensor (available from Yamatake Sensing Control, Ltd.), or an SL-630 Non-Invasive Disposable/Reusable Level Switch (available from Cosense, Inc. of Hauppauge, NY)  
20 may be employed to detect the fluid levels. Alternately or in addition, system 10 can include additional radiation and/or moisture detection sensors, which can detect leaks. With reference to Figure 1D, such sensors are preferably located in proximity to fittings 311, 312, 313, 314 and 315 that join portions of circuit 300 to one another. Some examples of leak detection sensors include, without limitation, those in the  
25 HPQ-D leak detection sensor family, and the HPF-D040 fiberoptic leak detector (all available from Yamatake Sensing Control, Ltd.). System 10 may further include additional sensors to detect contaminants and/or air bubbles within the tubing lines of circuit; examples of such sensors include the Point-air Detection (PAD) Sensor, that employs pulse-type ultrasound for air bubble detection, and the Blood Component  
30 Detector that employs optical sensing technology to perform Colorimetry-based fluid detection of unwanted elements in the tubing lines (both available from INTROTEK®).

According to those embodiments that include any of the above sensors, the sensors are linked into the controller of system 10 and/or computer 17, either of which may provide a signal to a user of system 10, when a flow anomaly is detected, and/or information to the user, via monitor 172, concerning fluid levels, pressure and/or flow through circuit 300. Computer 17 may be pre-programmed to display, for example, on  
5 monitor 172, a graphic of infusion circuit 300 wherein each zone of the circuit, where an anomaly has been detected, is highlighted, and/or to provide guidance, to the system user, for correcting the anomaly. It should be noted that the alternative infusion circuits illustrated in Figures 12A-B, which will be described below, may also  
10 include any or all of these types of sensors.

With further reference to Figure 1D, it may be appreciated that shielding assembly 200 encloses those portions of circuit 300 from which radioactive radiation may emanate, with the exception of that portion of patient line 305p, which must extend out from shielding assembly 200 in order to be coupled to the patient for  
15 injection, or in order to be coupled to shielded sample vials, as will be described below. Thus, technical personnel, who operate system 10, are protected from radiation by shielding assembly 200, except at those times when an infusion is taking place, or when quality control tests require collection of eluate into sample vials. During infusions and quality control test sample collection, all technical personnel are  
20 typically in another room, or otherwise distanced from system 10, in order to avoid exposure to radiation during the infusion, and, according to some preferred embodiments of the present invention, system 10 includes at least one means for informing technical personnel that an infusion is about to take place or is taking place. With reference back to Figures 1A and 1C, system 10 is shown including a light  
25 projector 100, mounted on post 142. According to the illustrated embodiment, projector 100, projects a light signal upward, for maximum visibility, when pump 33 is pumping eluant and elution is taking place within generator 21, or at all times when pump 33 is pumping eluant. According to some embodiments, the light signal flashes on and off when the eluate is being diverted from generator 21 into waste bottle 23,  
30 and the light signal shines steadily when the eluate is being diverted through patient line 305p, or visa versa. According to other embodiments, a projector 100 shines a light having a first color, to indicate that eluate is being diverted to waste bottle 23, and then shines a light having a second, different color, to indicate that eluate is being

directed to patient line 305p for infusion. Light projector 100 may further project a more rapidly flashing light, for example, for approximately five seconds, once a peak bolus of radioactivity is detected in the eluate, to provide further information to technical personnel. Alternative means of informing technical personnel that an infusion is taking place may also be incorporated by system 10, for example, including audible alarms or other types of visible or readable signals that are apparent at a distance from system, including in the control room.

It should be noted that, according to alternate embodiments, system 10 includes an 'on board' dose calibrator for quality control tests, and circuit 300 is expanded to include elements for an automated collection of eluate samples for activity measurements, via the on board dose calibrator. According to a first set of these alternate embodiments, a sample collection reservoir is integrated into circuit 300, downstream of divergence valve 35WP and in communication with tubing line 305P, in order to receive quality control test samples of eluate, via tubing line 305P, and both the reservoir and the dose calibrator are located in a separate shielded well. According to a second set of these alternate embodiments, waste bottle 23 is configured to receive the quality control test samples of eluate, via tubing line 305W, and a dose calibrator is integrated into shielding assembly 200. Quality control procedures will be described in greater detail below, in conjunction with Figures 6-8B.

When maintenance of system 10 requires the emptying waste bottle 23, relatively easy access to waste bottle 23 is provided through opening 139 in top surface 131 of shell 13. It should be noted that technical personnel are preferably trained to empty waste bottle 23 at times when the eluate, contained in waste bottle 23, has decayed sufficiently to ensure that the radioactivity thereof has fallen below a threshold to be safe. Opening 139 is preferably located at an elevation of between approximately 2 feet and approximately 3 feet; for example, opening 139 may be at an elevation of approximately 24 inches, with respect to a lower surface of platform 113, or at an elevation of approximately 32 inches, with respect to a ground surface upon which wheels 121, 122 rest. According to the illustrated embodiment, opening 139 is accessed by lifting panel 134; just within opening 139, a shielded lid or door 223 (Figure 2A) may be lifted away from a compartment of shielding assembly 200 that contains waste bottle 23. With further reference to Figure 1C, it may be appreciated that opening 137 provides access to other portions of circuit 300 for additional



maintenance procedures, such as changing out generator 21 and/or other components of circuit 300, as will be described below.

For those embodiments of system 10 in which automated quality control tests are performed and/or when system 10 is employed for relatively high volume  
5 operation, management of waste may become burdensome, even though access to waste bottle 23 is greatly facilitated, as described above. Thus, in order to facilitate waste management, some embodiments of system 10 may employ a separation system to separate salts, including radioactive elements, from water, for example, via evaporation or reverse osmosis. In an evaporation type system, the water component  
10 of the waste is evaporated, while in a reverse osmosis type system the water is separated from the salts, and, then, once confirmed to be non-radioactive, via a radiation detector, is piped to a drain. According to some other embodiments, circuit 300 may be configured so that the waste may be used to purge air from the tubing lines thereof and/or to perform the bypass flush that was described above, preferably after  
15 the radioactivity of the waste drops below a critical threshold.

Figures 1A and 1C further illustrate a pair of relatively shallow external recesses 190, which are formed in upper surface 131 of shell 13, for example, in order to catch any spills from infusion system; one of recesses 190 is shown located in proximity to post, or hanger 141, which holds reservoir 15, and in proximity to  
20 opening 133, through which tubing line 301 passes. Another recess 192 is shown formed in upper surface 131; a width and depth of recess 192 may accommodate storage of technical documentation associated with infusion system 10, for example, a technical manual and/or maintenance records, or printouts from printer 117 (Figure 1B). With reference to Figure 1C, upper surface 131 of shell 13 is shown to also  
25 include additional recesses 101, which are each sized to hold a shielded test vial, which contains samples from infusion system 10, for example, for breakthrough testing and/or calibration, which will be described in greater detail, below. An exemplary test vial shield is shown in Figure 1E. The test vial shield of Figure 1E is preferably formed from Tungsten rather than lead, for example, to reduce exposure to  
30 lead, for improved shielding, and to reduce the weight of the shield. Figure 1E illustrates the test vial shield including a handle to simplify manipulation thereof, but alternative configurations of test vial shields have no handle – for these a sling, or strap, may be employed for handling.

Additional receptacles 180 are shown formed in bin 18, on either side of a handle 182, which facilitates removal of bin 18 away from shell 13. Technical personnel may, thus, conveniently transport bin 18 to a storage area for a collection of supplies, for example, sharps, gloves, tubing lines, etc..., into one or more receptacles 180 thereof, and/or to a waste container where separate receptacles 180 of bin 18 may be emptied of waste, such as packaging for the aforementioned supplies, for example, deposited therein during infusion procedures. According to some embodiments, one or more additional receptacles are formed in one or more disposal containers, for example, to contain sharps and/or radioactive waste (other than that contained in waste bottle 23), which may be integrated into bin 18, or otherwise fitted into, or attached to shell 13, separate from bin 18.

Figure 2A is a perspective view of shielding assembly 200, according to some embodiments of the present invention. With reference to Figures 1C and 2A, together, it may be appreciated that opening 137, in upper surface 131 of shell 13, provides access to a lid or door 221 of a sidewall 201 of shielding assembly 200, which sidewall 201 encloses a compartment sized to contain a radioisotope generator of system 10, for example, generator 21, previously introduced. It should be noted that, according to alternate embodiments, the compartment enclosed by sidewall 201 is large enough to hold more than one generator, for example, to increase system operating efficiency for relatively high volume operation. In some of these alternate embodiments, tubing lines 304 and 305 are each branched for parallel flow through the multiple generators, in which case divergence valves may be employed to alternate the flow through the generators, one at a time. In others of these alternate embodiments, the multiple generators are connected in series between tubing line 304 and tubing line 305. In addition, a reservoir for accumulating eluate may be included in circuit 300, downstream of the generators and upstream of divergence valve 35 WP, in conjunction with a second pump, in some cases. Embodiments including multiple generators and/or an eluate reservoir and second pump can be employed to better manage an activity level of each dose, or patient injection, for example, as described below, in conjunction with Figures 12A-B.

According to the embodiment illustrated in Figure 2A, opening 137 and door 221 are located at a lower elevation, for example, with respect to platform 113, than are opening 139 and lid 223, which provide access to the compartment being formed

by a sidewall 203 of shielding assembly 200 to contain waste bottle 23, as previously described. When panel 132 is separated from shell 13, and door 221 opened, generator 21 may be lifted out from an opening 231 (Figure 3A) which mates with door 221 of sidewall 201. A weight of generator 21, which includes its own shielding, may be  
5 between approximately 23 and approximately 25 pounds, thus, according to some preferred embodiments of the present invention, the elevation of each of openings 137 and 231, with respect to the lowermost portion of the cabinet structure, is between approximately 1 foot and approximately 2 feet, in order to facilitate an ergonomic stance for technical personnel to lift generator 21 out from the compartment.  
10 According to an exemplary embodiment, when shielding assembly 200 is contained in the cabinet structure of Figure 1A, openings 137 and 231 are located at an elevation of approximately 12 inches, with respect to the lower surface of platform 113, or at an elevation of approximately 19 inches, with respect to the ground surface upon which wheels 121, 122 rest. Figure 1C further illustrates access panel 132 including a  
15 security lock 138, which mates with a framework 19 of system 10, shown in Figure 2B, in order to limit access to generator 21.

Figures 1C and 2A further illustrate a lid or a door 225 of another sidewall 205 (Figure 3A) of shielding assembly 200, which encloses another compartment that is accessible through opening 137 of shell 13, and which is located adjacent the  
20 compartment enclosed by sidewall 201. Each of doors 221, 225 are shown being attached by a corresponding hinge H, and another door 227 is shown attached to sidewall 203 by another hinge H. Figure 2A illustrates each of lid 223 and doors 221, 225, 227 including a handle 232, 212, 252 and 272, respectively, for moving lid 223 and doors 221, 225, 227, in order to provide access to the corresponding  
25 compartments, which can be seen in Figures 3A-B. Figure 2A further illustrates optional thumb screws 290, one securing lid 223 to sidewall 203 and another securing door 221 to sidewall 201, or other means for securing the doors, which are known to those skilled in the art, may be incorporated. Each sidewall 201, 203, 205 and the  
30 corresponding lid/door 223, 221, 225, 227 thereof may be individually cast from 3% antimony lead, or from other known shielding materials, and then assembled together according to methods known to those skilled in the art.

According to the illustrated embodiment, doors 221, 225 are hinged to open in an upward direction, per arrows D and C, and, with reference back to Figure 1C, a

latch component 191 is provided to hold each of doors 221, 225 in an opened position, thereby, preventing doors 221, 225 from falling closed, which could pinch/crush fingers of technical personnel and/or tubing lines of circuit 300, when in the midst of a maintenance procedure. Figure 2B is a perspective view of framework 19 of the cabinet structure of system 10, according to some embodiments, to which latch component 191 is mounted; Figure 2B includes an enlarged detailed view of latch component 191, according to some embodiments. Figure 2B illustrates latch component 191 including a first pin 193, corresponding to door 225, and a second pin 195, corresponding to door 221; each pin 193, 195 includes a lever end 193A, 193B, respectively, and a holding end 193B, 195B, respectively. An edge of each door 221, 225, upon opening of doors 221, 225, may push past the holding end 195B, 193B of the corresponding pin 195, 193, in a first direction, per arrow F, and then may rest against a respective side S95 and S93 of each end 195B, 193B, until the corresponding lever end 195A, 193A is rotated in a counter-clockwise direction, per arrow cc, thereby moving the corresponding holding end 193B, 195B to make way for the closing of doors 221, 225. Doors 221, 225 being held by latch component 191 in an open position may be seen in Figure 3A.

With further reference to Figure 2A, according to some preferred embodiments of the present invention, an edge of door 225 overlaps door 221 to prevent door 221 from being opened, per arrow D, if door 225 is not opened, per arrow C; and an edge of door 227 overlaps an edge of door 225 to prevent door 225 from being opened if door 227 is not opened, per arrow B; and an edge of lid 223 overlaps door 227 to prevent door 227 from being opened if lid 223 is not opened, per arrow A. Thus, access to the compartment enclosed by sidewall 201 and containing generator 21 is only systematically allowed through a sequential opening of lid 223 and doors 227, 225, 221, since, when generator 21 is replaced it is typically desirable to also replace those portions of circuit 300 which are shielded behind lid 223 and doors 227, 225. The routing of these portions of circuit 300 will be described in conjunction with Figures 3A-C.

Figure 3A is another perspective view of shielding assembly 200, according to some embodiments of the present invention. In Figure 3A, lid 223 and doors 221, 225, and 227 are opened to provide a view into openings 233, 235 and 231 of sidewalls 203, 205 and 201, respectively, and into a passageway 207, which is formed in

sidewall 203, opposite the compartment, which contains waste bottle 23. Passageway 207 is shown extending vertically along sidewall 203 and having a grooved extension 213 formed in a perimeter surface of opening 233. An optional retaining member 237, for example, formed from an elongate strip of resilient plastic having a generally c-  
5 shape cross-section, is shown being mounted along a length of passageway 207 to hold lines 305w and 305p in place within passageway 207. Figure 3A further illustrates a pair of passageways 251b and 251g, which are formed as grooves in a portion of sidewall 205, and another pair of passageways 215i and 215o, which are formed as grooves in a portion of sidewall 201. A routing of portions of tubing circuit 300  
10 (Figure 1D) through passageways 207, 251b, 251c, 215i and 215o is shown in Figure 3B.

Figure 3B illustrates tubing line 304 being routed through passageways 251g and 215i, eluate tubing line 305 being routed through passageway 215o, and both waste line 305w and patient line 305p being routed along passageway 207. Waste line  
15 305w further extends through grooved extension 213 to waste bottle 23, and patient line 305p further extends outward from shielding assembly 200, for example, to extend out through opening 135 in upper surface 131 of shell 13 (Figure 1A). According to the illustrated embodiment, each passageway formed in shielding assembly 200, by being accessible along a length thereof, can facilitate a relatively easy routing of the  
20 corresponding tubing line therethrough, when the corresponding lid/door is open, and a depth of each passageway prevents pinching and/or crushing of the corresponding tubing line routed therethrough, when the corresponding lid/door is closed down thereover. With further reference to Figures 3A-B, it may be appreciated that the compartment formed by sidewall 201 may have a shape matching an exterior contour  
25 of generator 21, such that generator 21 is 'keyed' to the compartment, for example, to prevent installation of an improper generator into system 10, and/or to facilitate the proper orientation of generator 21 within the compartment for the proper routing of tubing lines. Alternately, or in addition, according to alternate embodiments, if system  
30 10 includes a reader of encoded information in communication with computer 17, a unique identification and/or data associated with each generator may be provided, for example, in a bar code label or a radiofrequency identification (RFID) tag that is attached to each generator, so that the reader may transfer the information to computer 17, when a generator is installed, in order to either enable system operation or to

provide an indication to the user that an incorrect generator has been installed. Of course a user of system 10 may, alternately, manually enter information, that is provided on a generator label or marking, into computer 17, in order to either enable system 10, or to receive feedback from computer 17 that the incorrect generator is  
5 installed.

Figure 3A further illustrates sidewall 205 including a valve actuator receptacle 253, into which divergence valve 35WP is mounted, to be controlled by one of the servomotors (not shown) of system 10, and an opening 325 for activity detector 25. Activity detector 25 is mounted in a shielded well 255 that extends downward from  
10 opening 325 (shown in Figure 3B), and, with reference to Figure 3B, tubing line 305 passes over opening 325 so that detector 25 can detect an activity of the eluate, which passes therethrough. According to some embodiments, the positioning, within the compartment enclosed by sidewall 205, of the components of the portion of infusion circuit 300 which are shown routed therein, is facilitated by providing the components  
15 mounted in a frame 39 as a disposable subassembly 390, an embodiment of which is illustrated by Figures 3C-D.

Figure 3C is a perspective view of subassembly 390, and Figure 3D is a perspective view of frame 39. According to the embodiment illustrated by Figure 3D, frame 39 is formed from mating trays 39A, 39B, for example, formed from a  
20 thermoformed plastic, which fit together to capture, therebetween, and hold, in fixed relation to a perimeter edge of frame 39, divergence valve 35WP and portions of eluant tubing line 304, by-pass tubing line 303, eluate tubing line 305, waste line 305w and patient line 305p. Figure 3C illustrates the perimeter edge divided into a first side 391, a second side 392, opposite first side 391, a third side 393, extending between  
25 first and second sides 391, 392, and a fourth side 394, opposite third side 393. Although Figure 3D shows trays 39A, 39B individually formed for fitting together, according to alternate embodiments, mating trays of frame 39 may be parts of a continuous sheet of plastic folded over on itself.

According to the illustrated embodiment, an end 404A, of eluant line 304, and  
30 an end 403, of by-pass line 303 extend from third side 393 of frame 39 to couple with divergence valve 35BG and an upstream section of eluant tubing line 302. Figure 3C further illustrates an opposite end 404B of eluant line extending from first side 391 of frame 39, alongside a similarly extending end 405 of eluate line 305, and ends 406 and

407 of patient line 305p and waste line 305w, respectively, extending from second side 392 of frame 39. Although ends 406, 407 are shown extending upward from tray 39a, as they would within shielding assembly 200, it should be appreciated that the tubing lines of circuit 300 are preferably flexible and would drop down under their own  
5 weight rather than extending upward, as shown, if not supported. Referring back to Figure 1D, in conjunction with Figure 3C, it can be seen that the aforementioned fittings are provided for coupling subassembly 390 into circuit 300: first fitting 311 couples the section of eluant line 302 to filter 37; second fitting 312 couples eluant line 304 to an inlet port of generator 21; third fitting 313, which may incorporate a check  
10 valve, couples eluate line 305 to an outlet port of generator 21; fourth fitting 314 couples waste line 305w to waste bottle 23; and fifth fitting 315 couples patient line 305p to an extension thereof, which extends outside shell 13 (designated by the dotted line). Each of the fittings 311, 312, 313, 314, 315 may be of the Luer type, may be a type suitable for relatively high pressure applications, or may be any other suitable  
15 type that is known to those skilled in the art.

As previously mentioned, when generator 21 is replaced, it is typically desirable to also replace those portions of circuit 300 which are shielded behind lid 223 and doors 227, 225, and, in those instances wherein system 10 is moved to a new site each day, these portions may be replaced daily. Thus, according to the illustrated  
20 embodiment, these portions are conveniently held together by frame 39, as subassembly 390, in order to facilitate relatively speedy removal and replacement, while assuring a proper assembly orientation, via registration with features formed in sidewall 205 (Figure 3A), for example: registration of divergence valve 35WP with valve actuator receptacle 253, registration of tubing line ends 403 and 404A with  
25 passageways 251b and 251g, respectively, registration of tubing line ends 404B and 405 with passageways 215i and 215o, respectively, and registration of tubing line ends 406 and 407 with passageway 207.

With further reference to Figure 3B, other portions of tubing circuit 300 are shown. Figure 3B illustrates eluant tubing line 301 extending from reservoir 15,  
30 outside of shell 13 (Figure 1A), to syringe pump 33, which is mounted to an actuating platform 433. According to the illustrated embodiment, platform 433 is actuated by another servomotor (not shown) of system 10, which is controlled by the controller and computer 17 of system 10, to cause a plunger of pump 33 to move, per arrow I, so

as to draw in eluant, from reservoir 15, through tubing line 301, and then to cause the plunger to move in the opposite direction so as to pump the eluant, through tubing line 302, to either generator 21 or to by-pass line 303. Although the illustrated embodiment includes syringe pump 33, other suitable pumps, known to those skilled in the art, may be substituted for pump 33, in order to draw eluant from reservoir 15 and to pump the eluant throughout circuit 300. Although not shown, it should be appreciated that divergence valve 35BG is fitted into another valve actuating receptacle mounted within shell 13 and coupled to yet another servomotor (not shown) of system 10.

Figure 3B further illustrates a filter holder 317 that is mounted alongside an interior surface of shell 13 to hold filter 37 (Figure 1D) of tubing line 302. Filter holder 317, like frame 39 for subassembly 390, may be formed from a thermoformed plastic sheet; holder 317 may have a clam-shell structure to enclose filter 37 in an interior space, yet allow tubing line 302, on either side of filter 37, to extend out from the interior space, in between opposing sides of the clam-shell structure. Holder 317 is shown including an appendage 307 for hanging holder 317 from a structure (not shown) inside shell 13.

Turning now to Figures 4-9C details concerning computer-facilitated operation of system 10 will be described, according to some embodiments of the present invention. As previously mentioned, and with reference back to Figure 1A, computer 17 of system 10 includes monitor 172, which, preferably, not only displays indications of system operation to inform a user of system 10, but is also configured as a touch screen to receive input from the user. It should be understood that computer 17 is coupled to the controller of system 10, which may be mounted within the interior space surrounded by shell 13. Although Figure 1A shows computer 17 mounted to post 142 of system 10, for direct hardwiring to the controller of system 10, according to some alternate embodiments, computer 17 is coupled to the controller via a flexible lead that allows computer 17 to be positioned somewhat remotely from those portions of system 10, from which radioactive radiation may emanate; or, according to some other embodiments, computer 17 is wirelessly coupled, for example, via two-way telemetry, to the controller of system 10, for even greater flexibility in positioning computer 17, so that the operation of system 10 may be monitored and controlled remotely, away from radioactive radiation.



According to some preferred embodiments, computer 17 is pre-programmed to guide the user, via monitor 172, through procedures necessary to maintain system 10, to perform quality control tests on system 10, and to operate system 10 for patient infusions, as well as to interact with the user, via the touch-screen capability of monitor 172, according to preferred embodiments, in order to track volumes of eluant and eluate contained within system 10, to track a time from completion of each elution performed by system 10, to calculate one or more system parameters for the quality control tests, and to perform various data operations. Computer 17 may also be pre-programmed to interact with the controller of system 10 in order to keep a running tally or count of elutions per unit time, for a given generator employed by the system, and may further categorize each of the counted elutions, for example, as being generated either as a sample, for quality control testing, or as a dose, for patient injection. The elution count and categorization, along with measurements made on each sample or dose, for example, activity level, volume, flow rate, etc..., may be maintained in a stored record on computer 17. All or a portion of this stored information can be compiled in a report, to be printed locally, and/or to be electronically transferred to a remote location, for example, via an internet connection to technical support personnel, suppliers, service providers, etc..., as previously described. Computer 17 may further interact with the user and/or a reader of encoded information, for example, a bar code reader or a radiofrequency identification (RFID) tag reader, to store and organize product information collected from a product labels/tags, thereby facilitating inventory control, and/or confirming that the proper components, for example, of the tubing circuit, and/or accessories, and/or solutions are being used in the system.

It should be understood that screen shots shown in Figures 4-9C are exemplary in nature and are presented to provide an outline of some methods of the present invention in which computer 17 facilitates the aforementioned procedures, without limiting the scope of the invention to any particular computer interface format. Computer 17 may also include a pre-programmed user manual, which may be viewed on monitor 172, either independent of system operation or in conjunction with system operation, for example, via pop-up help screens. Although the English language is employed in the screen shots of Figures 4-9C, it should be understood that, according

to some embodiments, computer 17 is pre-programmed to provide guidance in multiple languages.

Figure 4 is a screen shot of a main menu 470, which is presented by computer 17 on monitor 172, according to some embodiments. Main menu 470 includes a listing of each computer-facilitated operation that may be selected by the user, once the user has logged on. According to some multi-lingual embodiments, computer 17 presents a list of languages from which the user may select, prior to presenting main menu 470.

Figure 5A is a schematic showing a series of screen shots which includes a log in screen 570. According to some embodiments, when the user touch-selects the data entry fields of screen 570 or 571, or of any of the other screens presented herein, below, a virtual keyboard is displayed for touch-select data entry into the selected data entry field; alternately, computer 17 may be augmented with another type of device for user data entry, examples of which include, without limitation, a peripheral keyboard device, a storage medium (i.e. disk) reader, a scanner, a bar code reader (or other reader of encoded information), a hand control (i.e. mouse, joy stick, etc...). Although not shown, according to some embodiments, screen 570 may further include another data entry field in which the user is required to enter a license key related to the generator employed by system 10 in order to enable operation of system 10; the key may be time sensitive, related to generator contract terms. Of course any number of log in requirements may be employed, according to various embodiments, and may be presented on multiple sequentially appearing screens rather than on a single log in screen.

After the user enters the appropriate information into data entry fields of log in screen 570, computer 17 presents a request for the user to confirm the volume of eluant that is within reservoir 15 (e.g. saline in saline bag), via a screen 571, and then brings up main menu 470. If the user determines that the volume of eluant/saline is insufficient, the user selects a menu item 573, to replace the saline bag. If system 10 includes an encoded information reader, such as a bar code or RFID tag reader, confirmation that the selected reservoir is proper, i.e. contains the proper saline solution, may be carried out by computer 17, prior to connecting the reservoir into circuit 300, by processing information read from a label/tag attached to the reservoir. Alternatively, or in addition, tubing line 301 of circuit 300 may be provided with a

connector which only mates with the proper type of reservoir 15. According to some embodiments, system 10 may further include an osmolarity or charge detector, which is located just downstream of reservoir 15 and is linked to computer 17, so that an error message may be presented on monitor 172 stating that the wrong osmolarity or charge is detected in the eluant supplied by reservoir, indicating an improper solution. One example of a charge detector that may be employed by system 10 is the SciCon™ Conductivity Sensor (available from SciLog, Inc. of Middleton, WI).

Once the reservoir/saline bag is successfully replaced, computer 17 prompts the user to enter a quantity of saline contained by the new saline bag, via a screen 574. Alternately, if system 10 includes the aforementioned reader, and the saline bag includes a tag by which volume information is provided, the reader may automatically transfer the quantity information to computer 17. Thus, computer 17 uses either the confirmed eluant/saline volume, via screen 571, or the newly entered eluant/saline volume as a baseline from which to track depletion of reservoir volume, via activations of pump 33, in the operation of system 10. With reference to Figure 5B, during the operation of system 10, when computer 17 detects that the eluant reservoir/saline bag has been depleted to a predetermined volume threshold, computer 17 warns the user, via a screen 577. If the user has disregarded screen 577 and continues to deplete the saline bag, computer 17 detects when the saline bag is empty and provides indication of the same to the user, via a screen 578. To replenish the reservoir/saline bag, the user may either refill the reservoir/bag or replace the empty reservoir/bag with a full reservoir/bag. According to some embodiments, system 10 automatically precludes any further operation of the system until the reservoir is replenished. It should be noted that, as previously mentioned, system 10 can include a fluid level sensor coupled to the eluant reservoir in order to detect when the level of saline drops below a certain level.

In addition to tracking the volume of eluant in reservoir 15, computer 17 also tracks a volume of the eluate which is discharged from generator 21 into waste bottle 23. With reference to Figure 5C, an item 583 is provided in main menu 470, to be selected by the user when the user empties waste bottle 23. When the user selects item 583, computer 17 presents a screen 584, by which the user may effectively command computer 17 to set a waste bottle level indicator to zero, once the user has emptied waste bottle 23. Typically, the user, when powering up system 10 for operation, each

day, will either empty waste bottle 23, or confirm that waste bottle 23 was emptied at the end of operation the previous day, and utilize screen 584 to set the waste bottle level indicator to zero. Thus, computer 17, can track the filling of waste bottle 23 via monitoring of the operation of pump 33 and divergence valve 35WP, and provide an indication to the user when waste bottle 23 needs to be emptied, for example, via presentation of screen 584, in order to warn the user that, unless emptied, the waste bottle will overflow. According to some embodiments, system 10 automatically precludes any further operation of the system until the waste bottle is emptied.

According to some alternative embodiments, a fluid level sensor may be coupled to waste bottle, for example, as mentioned above in conjunction with Figure 1D, in order to automatically detect when waste bottle is filled to a predetermined level and to provide, via computer 17, an indication to the user that waste bottle 23 needs to be emptied and/or to automatically preclude operation of system 10 until the waste bottle is emptied.

In addition to the above maintenance steps related to eluant and eluate volumes of system 10, the user of system 10 will typically perform quality control tests each day, prior to any patient infusions. With reference to Figure 6, according to preferred methods, prior to performing the quality control tests (outlined in conjunction with Figures 7A-C and 8A-B), the user may select an item 675 from main menu 470, in order to direct system 10 to wash the column of generator 21. During the generator column wash, which is performed by pumping a predetermined volume of eluant, for example, approximately 50 milliliters, through generator 21 and into waste bottle 23, computer 17 provides an indication, via a screen 676, that the wash is in progress. Also, during the generator column wash, the system may provide a signal to indicate that eluate is being diverted to waste bottle 23, for example, light projector 100 (Figure 1C) may project a flashing light signal, as previously described.

Figure 6 further illustrates a screen 677, which is presented by computer 17 upon completion of the column wash, and which provides an indication of a time lapse since the completion of the wash, in terms of a time countdown, until a subsequent elution process may be effectively carried out. While screen 677 is displayed, system 10 may be refilling, from reservoir 15, pump 33, which has a capacity of approximately 55 milliliters, according to some embodiments. According to some preferred embodiments of the present invention, computer 17 starts a timer once any

elution process is completed and informs the user of the time lapse, either in terms of the time countdown (screen 677), or in terms of a time from completion of the elution, for example, as will be described in conjunction with Figure 7B. According to an exemplary embodiment, wherein generator 21 is the CardioGen-82® that yields a saline solution of Rubidium-82, produced by the decay of Strontium-82, via the elution, a time required between two effective elution processes is approximately 10 minutes.

Once the appropriate amount of time has lapsed, after the elution process of generator column wash, a first quality control test may be performed. With reference to Figure 7A, the user may select, from main menu 470, an item 773A, which directs computer 17 to begin a sequence for breakthrough testing. According to some embodiments, in conjunction with the selection of item 773A, the user attaches a needle to an end of patient line 305p and inserts the needle into to a test vial, for the collection of an eluate sample therefrom, and, according to Figure 7A, computer 17 presents a screen 774, which instructs the user to insert the test vial into a vial shield, which may be held in recess 101 of shell 13 (Figure 1C).

Figure 7A further illustrates a subsequent screen 775, by which computer 17 receives input, from the user, for system 10 to start the breakthrough elution, followed by a screen 776, which provides both an indication that the elution is in progress and an option for the user to abort the elution. As previously described, the system may provide a signal to indicate that elution is in progress, for example, light projector 100 (Figure 1C) may project a flashing light signal during that portion of the elution process when eluate is diverted from generator 21 through waste line 305w and into waste bottle 23, and then a steady light signal during that portion of the elution process when the eluate is diverted from generator 21 through patient line 305p and into the test vial, for example, once activity detector 25 detects a dose rate of approximately 1.0 mCi/sec in the eluate discharged from generator 21. Another type of light signal, for example, the more rapidly flashing light, as previously described, may be projected when a peak bolus of radioactivity is detected in the eluate.

Upon completion of the elution process for breakthrough testing, computer 17 presents a screen 777, shown in Figure 7B, which, like screen 677, provides an indication of a time lapse since the completion of the elution, but now in terms of a time since completion of the breakthrough elution process. When the user transfers

the vial containing the sample of eluate into a dose calibrator, to measure the activity of the sample, the user may make a note of the time lapse indicated on screen 777. With further reference to Figure 7B, once the user has received the activity measure from the dose calibrator, the user proceeds to a screen 778, which includes data entry fields for the activity measure and the time between that at which the dose calibrator measured the activity of the sample and that at which the elution was completed. The user may enter the data via the touch-screen interface of monitor 172, or via any of the other aforementioned devices for user data entry. According to some alternate embodiments, computer 17 may receive the data, electronically, from the dose calibrator, either via wireless communication or a cable connection.

After the data is entered by the user, computer 17 presents screen 779, from which the user moves back to main menu 470 to perform a system calibration, for example, as will be described in conjunction with Figures 8A-B, although the breakthrough testing is not completed. With reference back to Figure 7A, an item 773B is shown, somewhat faded, in main menu 470; item 773B may only be effectively selected following the completion of steps for item 773A, so as to perform a second stage of breakthrough testing. In the second stage, the breakthrough of the sample of eluate collected in the test vial for the breakthrough testing is measured, at a time of approximately 60 minutes from the completion of the elution that produced the sample. With reference to Figure 7C, after the user has selected item 773B from main menu 470, in order to direct computer 17 to provide breakthrough test results, a screen 781 is displayed. Screen 781 includes, for reference, the values previously entered by the user in screen 778, along with another pair of data entry fields into which the user is instructed to enter the breakthrough reading of the sample at 60 minutes and the background radiation reading, respectively. After the user enters this remaining information, as described above, computer 17 may calculate and then display, on a screen 782, the breakthrough test results. According to the illustrated embodiment, computer 17 also displays on screen 782 pre-programmed allowable limits for the results, so that the user may verify that the breakthrough test results are in compliance with acceptable limits, before moving on to a patient infusion. According to some embodiments, system 10 will not allow an infusion if the results exceed the acceptable limits, and may present a screen explaining that the results are outside the acceptable

limits; the screen may further direct the user to contact the generator supplier, for example, to order a replacement generator.

With reference to Figure 8A, during the aforementioned 60 minute time period, while waiting to complete the breakthrough testing, the user may perform calibration  
5 by selecting item 873 from main menu 470. Upon selection of item 873, computer 17 presents a screen 874, which instructs the user to insert a new test vial into an elution vial shield. In addition to placing the vial in the shield, the user, preferably, replaces patient line 305p with a new patient line, and then attaches a needle to the end of the new patient line for insertion into the test vial, in order to collect an eluate sample  
10 therefrom. After performing these steps, the user may move to screen 875, wherein a plurality of data entry fields are presented; all or some of the fields may be filled in with pre-programmed default parameters, which the user has an option to change, if necessary. Once the user confirms entry of desired parameters for the calibration, the user may enter a command, via interaction with a subsequent screen 876, to start the  
15 calibration elution.

With reference to Figure 8B, after computer 17 starts the elution process, a screen 87 informs the user that the calibration elution is in progress and provides an option to abort the elution. As previously described, the system may provide an indication that elution is in progress, for example, light projector 100 (Figure 1C) may  
20 project a flashing light signal during that portion of the elution process when eluate is diverted from generator 21 through waste line 305w and into waste bottle 23, and then a steady light signal during that portion of the elution process when activity detector 25 has detected that a prescribed dose rate threshold is reached, for example, 1.0 mCi/sec, and the eluate is being diverted from generator 21, through the new patient  
25 line, and into the test vial. Another type of light signal, for example, the more rapidly flashing light, as previously described, may be projected when a peak bolus of radioactivity is detected in the eluate. Upon completion of the elution process for calibration, computer 17 presents a screen 878, which provides an indication of a time lapse since the completion of the elution, in terms of a time since completion of the  
30 calibration elution process. When the user transfers the vial containing the sample of eluate into the dose calibrator, to measure the activity of the sample, the user may make a note of the time lapse indicated on screen 878. With further reference to Figure 8B, once the user has received the activity measure from the dose calibrator, the

user proceeds to a screen 879, which includes data entry fields for the activity measure and the time, with respect to the completion of elution, at which the dose calibrator measured the activity of the sample. Once the data is input by the user, as described above, computer calculates a calibration coefficient, or ratio, and presents the ratio on  
5 a screen 880. According to Figure 8B, screen 880 further provides an indication of a desirable range for the calibration ratio and presents an option for the user to reject the calculated ratio, in which case, the user may instruct computer 17 to recalculate the ratio.

As previously mentioned, some alternate embodiments of the present invention  
10 include an on board dose calibrator so that the entire sequence of sample collection and calculation steps, which are described above, in conjunction with Figures 6-8B, for the quality control procedures, may be automated. This automated alternative preferably includes screen shots, similar to some of those described above, which provide a user of the system with information at various stages over the course of the  
15 automated procedure and that provide the user with opportunities to modify, override and/or abort one or more steps in the procedure. Regardless of the embodiment (i.e. whether system 10 employs an on board dose calibrator or not), computer 17 may further collect all quality control test parameters and results into a stored record and/or compile a report including all or some of the parameters and results for local print out  
20 and/or electronic transfer to a remote location.

With reference to Figure 9A, upon completion of the above-described quality control tests, the user may select an item 971, from main menu 470, in order to direct system 10 to begin a procedure for the generation and automatic infusion of a  
25 radiopharmaceutical into a patient. As previously described, system 10 infuses the patient with the radiopharmaceutical so that nuclear diagnostic imaging equipment, for example, a PET scanner, can create images of an organ of the patient, which absorbs the radiopharmaceutical, via detection of radioactive radiation therefrom. According to Figure 9A, upon selection of item 971, computer 17 presents a screen 972 which includes a data entry field for a patient identification number. This identification  
30 number that is entered by the user is retained by computer 17, in conjunction with the pertinent system parameters associated with the patient's infusion. After the user enters the patient identification number, computer 17 directs, per a screen 973, the user to attach a new patient line and to purge the patient line of air. A subsequent screen



974 presented by computer 17 includes data entry fields by which the user may establish parameters for the automatic infusion; all or some of the fields may be filled in with pre-programmed default parameters, which the user has an option to change, if necessary.

5           With reference to Figure 9B, if pump 33 does not contain enough eluant/saline for the patient infusion, computer 17 will present a warning, via a screen 901, which includes an option for the user to direct the refilling of pump 33, via a subsequent screen 902. Once pump 33 has been filled, computer 17 presents an indication to the user, via a screen 903. According to some embodiments, if the user does not re-fill  
10       pump 33, yet attempts to proceed with an infusion, system 10 will preclude the infusion and present another screen, that communicates to the user that no infusion is possible, if the pump is not refilled, and asking the user to refill the pump, as in screen 901. When pump 33 contains a sufficient volume of eluant for the patient infusion, computer 17 presents a screen 975, which is shown in Figure 9C, and allows the user  
15       to enter a command for system 10 to start the patient infusion. During the infusion, computer 17 provides the user with an indication that the infusion is in process and with a option for the user to abort the infusion, via a screen 976. As previously described, the system may provide an indication that an elution is in progress, for example, light projector 100 (Figure 1C) may project a flashing light signal during that  
20       portion of the elution process when eluate is diverted from generator 21 through waste line 305w and into waste bottle 23, and then a steady light signal during that portion of the elution process when activity detector 25 has detected that a prescribed dose rate threshold is reached, for example, 1.0 mCi/sec, and the eluate is being diverted from generator 21, through the new patient line for infusion into the patient. Another type  
25       of light signal, for example, the more rapidly flashing light, previously described, may be projected when a peak bolus of radioactivity is detected in the eluate. At the completion of the infusion, a screen 977 is displayed by computer 17 to inform the user of the completion of the infusion and a time since the completion. Computer 17 also displays a summary of the infusion, per screen 978.

30           With further reference to Figure 9C, screen 976 shows an exemplary activity profile (activity - mCi/sec, on y-axis, versus time - sec, on x-axis) for the infusion/injected dose (designated between the two vertical lines). Those skilled in the art will appreciate that the shape of this profile depends upon the infusion flow rate,

for a given volume of the dose, which flow rate is controlled, for example, by the speed at which pump 33 drives flow through the patient line, and upon the amount of Strontium-82 remaining in the generator. In the absence of flow rate control, activity profiles may change over the life of the generator. Furthermore, the peak bolus of radioactivity, particularly for injected doses from a relatively new generator, may exceed a saturation level of the imaging equipment, i.e. PET scanner. According to some preferred methods of the present invention, in order to maintain relatively consistent, and desirable/effective, activity profiles for patient injections, over the life of the generator, the operating speed of pump 33 may be varied (both over the course of a single injection and from injection to injection), according to feedback from activity detector 25. Such a method may be implemented via incorporation of another quality control test in which pump 33 is operated to drive flow through the generator at a constant rate, in order to collect, into computer, a plurality of activity measurements from activity detector 25; the plurality of measurements comprise a characteristic, or baseline activity profile from which the computer 17 may calculate an appropriate flow rate profile to control a speed of pump 33, in order to achieve the desirable/effective activity profile. In general, at the start of generator life, when Strontium-82 is plentiful, the pump is controlled to drive infusion flow at relatively lower rates, and, then, toward the end of generator life, when much of the Strontium-82 has been depleted, the pump is controlled to drive infusion flow at relatively higher rates. As was described above, in conjunction with Figure 1D, if a desired infusion/injection flow rate is relatively high, that is, high enough to create too much back pressure, via flow through the column of generator 21, by-pass line 303 may be employed by adjusting divergence valve 35BG to divert a flow of eluant therethrough after a sufficient volume has been pumped through generator at a lower flow rate. According to this method, once a dose of eluate, from generator 21, has flowed into patient line 305p, divergence valve 35BG is set to divert the flow of eluant through by-pass line 303, and then pump speed is increased to pump eluant at a higher flow rate in order to push the dose out from patient line 305p, for injection at the higher flow rate.

Consistency of activity profiles among injected doses can greatly facilitate the use of PET scanning for the quantification of flow, for example, in coronary perfusion studies. Alternative infusion circuit configurations, operable according to alternative methods, to achieve consistency of activity profiles among injected doses, as well as a

more uniform level of radioactivity across each individual dose, will be described below, in conjunction with Figures 12A-C.

Printer 117 (Figure 1B) may be activated to print out a hard copy of the infusion summary, on which the patient identification number and pertinent infusion  
5 and system parameters are also printed, for reference. Alternatively, or in addition, according to some embodiments, the summary may be downloaded onto a computer readable storage device to be electronically transferred to one or more remote computers and/or the summary may be automatically transferred to the one or more  
10 remote computers, via wireless communication or a cable connection, for example, over an intranet network and/or the internet. In order to protect private patient information, the files may be encrypted for transmission over the internet. The one or more remote computers may be included, for example, in a hospital information system, and/or a billing system, and/or in a medical imaging system. Infusion  
15 parameters, for example, corresponding to the activity profile, may also be collected and electronically transferred for analysis in conjunction with captured images, for example, in order to quantify coronary flow, via a software package that is loaded into a system that includes the PET scanner.

With reference back to Figure 9A the user may select an item 995, from main menu 470, in order have system 10 perform data operations, such as, archiving a data  
20 base of patient infusion information and quality control test results, transmitting patient infusion summary records to USB mass storage devices, and various types of data filtering, for example, according to date ranges and/or patient identification numbers, for example, to search for a particular set of data and/or to compile a  
25 summary report of related sets of data. Additionally, certain information, which is collected by computer 17 over the course of system operation, and which defines system operation, may be transmitted to a local or remote computerized inventory system and/or to computers of technical support personnel, maintenance/service  
30 providers and/or suppliers of infusion circuit elements/components, thereby facilitating more efficient system operation and maintenance.

Turning now to Figure 10, an item 981 for computer-facilitated purging of the tubing lines of system 10 is shown included in main menu 470. When a user selects item 981, computer 17 guides the user to select either an air purge or a saline purge. The direction provided by computer 17 is not explicitly laid out herein, for a saline

purge, as procedures for saline purging should be readily apparent to those skilled in the art, with reference to the schematic of infusion circuit 300 shown in Figure 1D. A saline purge of circuit 300 is desired to assure that all the air is removed from circuit 300 when a new generator and/or a new complete or partial tubing set is installed. An  
5 air purge of the tubing lines of circuit 300 may be performed after removing reservoir 15, by-passing generator 21, by connecting tubing line 304 to tubing line 305, and coupling patient line 305p to a vial, for example, as is directed by the computer interface, in screens 983 and 984 shown in Figure 10. The air purge is desirable for blowing out the tubing lines, thereby removing all remaining eluant and eluate, prior to  
10 installing a new generator and/or prior to transporting system 10 from one site to another. If generator 21 is not depleted and will be used in system 10 at the new site, it is important to by-pass the generator prior to purging the tubing lines of circuit 300 with air, so that air is not blown across the generator, since air through generator 21 may compromise both the function and the aseptic nature of generator 21.

15 According to preferred embodiments, once the user has followed the instructions presented in screens 983 and 984 and selects to start the air purge, for example, via screen 985, computer 17 directs the controller of system 10 to carry out a complete air purge, in which pump 33 and divergence valves 35BG and 35WP are automatically controlled. The automated air purge preferably includes the following  
20 steps, which may be best understood with reference to tubing circuit 300 in Figure 1D: pumping any remaining volume of eluant left in pump 33, through lines 302, 304, 305 and 305w, to waste bottle 23; refilling pump 33 with air and pumping the air through lines 302, 304, 305 and 305w, into waste bottle 23 (lines 304 and 305 have been previously connected directly to one another, in order to by-pass generator 21; if  
25 generator 21 is depleted and will be replaced with a new generator, pumping air through generator 21 may be acceptable); refilling pump 33 with air and then pumping a portion of the air through lines 302, 304, 305 and 305p, into the vial, and then a remaining portion of the air through lines 302, 304, 303 and 305p, into the vial. With  
30 reference to Figure 1D and the previous description of divergence valves 35BG, 35WP, it should be understood how divergence valves 35BG, 35WP are automatically controlled to carry out the above steps.

The purge operations, which are facilitated by selecting item 981 from main menu 470, may also be accessed via the selection of an item 991 for generator setup.

When the user selects item 991, computer 17 may present an option for guidance in removing an old, depleted, generator and a set of tubing lines, prior to installing the new generator, or an option to just be guided in the installation of the new generator. According to some embodiments, computer 17 is pre-programmed to calculate an amount of activity left in a depleted generator, for example, by tracking activity of eluate over a life of the generator. At an end of the life of the generator, computer 17 may further compile this information, along with other pertinent generator information, into a report that may accompany a declaration of dangerous goods for shipping the depleted generator out for disposal or, in some cases, back to the manufacturer for investigation. An example of such a report is shown in Figure 11. According to those embodiments of system 10 that include an encoded information reader, computer 17 may confirm that the new generator is proper by processing information that is read from an encoded label/tag attached thereto.

Figures 12A-B are schematics of alternative infusion circuits 1300A, 1300B that may be employed by system 10, in place of circuit 300 (Figure 1D), according to some additional embodiments of the present invention. Circuits 1300A, 1300B are configured to allow for alternative methods of operation, to that previously described for circuit 300, when a relatively even, or uniform level of activity over each injected dose, along with the relatively consistent level of activity from injection to injection is desired, for example, in order to facilitate a quantification of coronary artery blood flow via PET scanning. Figure 12C is a schematic illustrating activity profiles 1200A, 1200B for two injected doses, wherein profile 1200B has a more uniform level of activity than profile 1200A; profile 1200B may be achieved via the operation of circuits 1300A, 1300B as described below.

Similar to circuit 300 (Figure 1D), dashed lines are shown in each of Figures 12A-B to indicate a general boundary of a shielding assembly for portions of each circuit 1300A, 1300B. The shielding assembly for each of circuits 1300A, 1300B may be very similar, in most respects, to shielding assembly 200, which is described above for system 10, and the elements of each of circuits 1300A, 1300B may be arranged with respect to their respective shielding and with respect to shell 13 of system 10 in a similar manner to that described above for circuit 300.

Figure 12A illustrates circuit 1300A including, like the previously described circuit 300, eluant reservoir 15, pump 33, radioisotope generator 21, through which the

filtered eluant is pumped to create the radioactive eluate, activity detector 25, and waste bottle 23. Figure 12A further illustrates two filters 37 and two pressure transducers 1334 included in circuit 1300A. Circuit 1300A further includes by-pass tubing line 303, which is located downstream of divergence valve 35BG, like in circuit 300, and which accommodates the previously described eluant/saline flush. However, in contrast to circuit 300, circuit 1300A further includes a linear/proportional valve 1335 integrated into by-pass/flush line 303 so that circuit 1300A may be operated, for example, according to pre-programmed parameters of computer 17, in conjunction with feedback of information from activity detector 25, for a controlled by-pass of generator 21 in order to mix eluant with eluate and, thereby, achieve a relatively uniform level of activity over each patient injection, for example, according to profile 1200B of Figure 12C. It should be noted that, in addition to the controlled mixing, a flow rate of each injection may be varied, if necessary, in order to maintain a consistent activity level.

Figure 12B illustrates circuit 1300B including, like the previously described circuit 300, eluant reservoir 15, pump 33, radioisotope generator 21, activity detector 25, and waste bottle 23, as well as the two filters 37 and two pressure transducers 1334, as in circuit 1300A. In contrast to circuits 300 and 1300A, circuit 1300B further includes an eluate reservoir 1350, which is shown located downstream of generator 21, in between first and second segments 305A, 305B of the eluate tubing line. It should be noted that a pump is combined with reservoir 1350, for example, similar to syringe pump 33, such that, when a divergence valve 1335IO is set to allow fluid communication between reservoir 1350 and tubing line segment 305A, the associated pump may be operated to draw in a volume of eluate, and, then, when divergence valve 1335IO is set to allow fluid communication between reservoir 1350 and tubing line segment 305B, the pump may be operated to push the volume of eluate out through tubing line segment 305B for a patient injection, when divergence valve 35WP is set to direct flow into patient line 305p. With reference back to Figures 3A-B, sidewall 205 of shielding assembly 200 may be enlarged to further enclose eluate reservoir 1350. For example, another shielded well, to house the eluate reservoir, may extend alongside well 255, in which activity detector 25 is described as being mounted. Furthermore, sidewall 205 may include another valve actuator receptacle for

divergence valve 1335IO, similar to receptacle 253, shown in Figure 3A for divergence valve 35WP.

Collection of discrete volumes of eluate, in reservoir 1350, may help to achieve a more uniform activity level over each injection, for example, like that of profile 1200B in Figure 12C, and, according to preferred methods, feedback from activity detector 25 may be used to control the pump associated with reservoir 1350, in order to vary injection flow rate and, thereby, maintain a relatively consistent activity level across multiple injections, and, when necessary, to vary injection flow rate over an individual injection to maintain the uniform activity level. Feedback from the pressure transducer 1334, that is downstream from detector 25, and/or from a flow meter (not shown) of circuit 1300B may also be used to control the varying of injection flow rate.

With further reference to Figures 12A-B, it should be noted that alternative circuits may be configured to employ a combination of the methods described for circuits 1300A and 1300B. Furthermore, some infusion circuits of the present invention may employ multiple generators 21, as mentioned above, in conjunction with Figure 2A, to help maintain the relatively uniform level of activity over each injection and the relatively consistent level of activity from injection to injection.

In the foregoing detailed description, the invention has been described with reference to specific embodiments. However, it may be appreciated that various modifications and changes can be made without departing from the scope of the invention as set forth in the appended claims.

25

THE CLAIMS DEFINING THE INVENTION ARE AS FOLLOWS:

1. A shielding assembly for a system that generates and infuses radiopharmaceuticals, the shielding assembly comprising:

5 a first compartment sized to contain one or more radioisotope generators of the system, the first compartment being enclosed by a first sidewall that forms a barrier to radioactive radiation, the first sidewall including an opening extending through the first sidewall, the opening being oriented upward and located at a first elevation with respect to ground level;

10 a second compartment sized to contain a portion of an infusion circuit of the system that is downstream of the one or more generators, the second compartment being enclosed by a second sidewall that forms a barrier to radioactive radiation, the portion of the infusion circuit including an eluate tubing line, a patient line, and a waste line, the patient line and the waste line both being  
15 coupled to the eluate tubing line;

a third compartment sized to contain a waste bottle of the system, the third compartment being enclosed by a third sidewall that forms a barrier to radioactive radiation, the third sidewall including an opening, extending through the third sidewall, the opening of the third sidewall being oriented upward and  
20 located at a second elevation, with respect to ground level, and the second elevation being greater than the first elevation of the opening of the first sidewall;

a first door mating with the opening of the first sidewall to alternately enclose the first compartment and provide access to the first compartment;

25 a second door mating with the opening of the second sidewall to alternately enclose the second compartment and provide access to the second compartment; and

a third door mating with the opening of the third sidewall to alternately enclose the third compartment and provide access to the third  
30 compartment,



wherein the first door defines a first door edge, the second door defines a second door edge, and the second door edge overlaps the first door edge so as to prevent the first door from being opened if the second door is not open.

5 2. The shielding assembly of Claim 1, wherein the first elevation is between approximately 12 inches and approximately 24 inches.

3. The shielding assembly of Claim 1 or 2, wherein the second elevation is between approximately 24 inches and approximately 36 inches.

10

4. The shielding assembly of any one of the preceding Claims, further comprising:

15 a fourth compartment sized to contain another portion of the infusion circuit of the system downstream from the one or more generators, the fourth compartment being enclosed by a portion of the third sidewall and a fourth door that forms a barrier to radioactive radiation, the fourth door mating with the portion of the third sidewall to alternately enclose the fourth compartment and provide access to the fourth compartment; and

20 wherein the fourth compartment is immediately adjacent to the second compartment; and

the other portion of the infusion circuit, for which the fourth compartment is sized to contain, includes an extension of the patient line, from the second compartment, and an extension of the waste line, from the second compartment.

25 5. The shielding assembly of Claim 4, wherein the fourth compartment extends approximately vertically along the portion of the third sidewall, on an opposite side of the third sidewall from the third compartment.

30 6. The shielding assembly of Claim 5, wherein the fourth compartment includes a retaining member to hold the extension of the patient line and the

extension of the waste line in place within the fourth compartment.

7. The shielding assembly of Claim 4, 5 or 6, wherein a lid of the third sidewall, when mated with opening of the third sidewall, prevents the door of the fourth compartment from opening to provide access to the fourth compartment.

8. The shielding assembly of Claim 7, wherein the fourth door, when mated with the portion of the third sidewall, prevents the second door from opening to provide access to the second compartment.

10

9. A method for setting up an infusion system, the method comprising:  
opening a first door of a shielding assembly of the infusion system to access a first compartment of the assembly and to allow for a second door of the shielding assembly to be opened, wherein the first door defines a first door edge, the second door defines a second door edge, and the first door edge overlaps the second door edge so as to prevent the second door from being opened if the first door is not open; and

opening the second door, after opening the first door, to access a second compartment of the shielding assembly, the second compartment being separate from, and outside of, the first compartment;

placing a radioisotope generator into the second compartment and connecting the generator to an infusion tubing circuit;

placing a portion of the infusion tubing circuit into the first compartment;

closing the second door to enclose the generator within the second compartment; and

closing the first door, after closing the second door, to enclose the portion of the infusion tubing circuit within the first compartment.

10. The method of Claim 9, further comprising unlocking and removing an access panel from a shell of a cabinet structure, which encloses the shielding

assembly, to access the first door and the second door of the shielding assembly.

11. The method of Claim 9 or 10, further comprising:

5 opening a third door, prior to opening the first door, to access a third compartment of the shielding assembly and to allow for the first door to be opened;

placing another portion of the infusion tubing circuit into the third compartment; and

10 closing the third door, after closing the first door, to enclose the other portion of the infusion tubing circuit within the third compartment.

12. The method of Claim 11, further comprising unlocking and removing an access panel from a shell of a cabinet structure, which encloses the shielding assembly, to access the first door, the second door and the third door of the shielding assembly.

13. The method of Claim 11 or 12, further comprising:

20 opening a fourth door, prior to opening the third door, to access a fourth compartment of the shielding assembly and to allow for the third door to be opened;

connecting a waste line of the infusion tubing circuit to a waste bottle; placing the waste bottle into the fourth compartment; and closing the fourth door, after closing the third door, to enclose the waste bottle within the fourth compartment.

25

14. The method of any one of Claims 9 to 13, further comprising securing at least one of the first and second doors in an open position.

15. A shielding assembly for a system that generates and infuses radiopharmaceuticals, the shielding assembly comprising a first compartment and

30

a second compartment, the first compartment being enclosed by a first sidewall of the shielding assembly and the second compartment being enclosed by a second sidewall of the shielding assembly, each of the first and second sidewalls providing a radioactive radiation barrier for the corresponding compartment and each including a door;

a first of the doors to alternately enclose and provide access to the first compartment; and a second of the doors to alternately enclose and provide access to the second compartment; and the shielding assembly being characterized in that:

the first compartment is sized to contain one or more radioisotope generators of the system;

the second compartment is separate from, and outside of, the first compartment, being located adjacent thereto, and is sized to contain a portion of an infusion circuit of the system that is downstream of the one or more generators; and the second door is configured such that, when the second door encloses the second compartment, the second door prevents the first door from opening to provide access to the first compartment wherein the first door defines a first door edge, the second door defines a second door edge, and the second door edge overlaps the first door edge so as to prevent the first door from being opened if the second door is not open.

16. The shielding assembly of Claim 15, further comprising a third compartment being enclosed by a third sidewall of the shielding assembly, the third sidewall providing a radioactive radiation barrier for the third compartment and including a third door to alternately enclose and provide access to the third compartment; the third compartment is sized to contain another portion of the infusion circuit of the infusion system that is downstream from the one or more generators; and the third door is configured such that, when enclosing the third compartment, the third door prevents the second door from opening to provide access to the second compartment.

17. The shielding assembly of Claim 16, further comprising a fourth compartment being enclosed by the third sidewall, the third sidewall providing a radioactive radiation barrier for the fourth compartment and including a fourth door to alternately enclose and provide access to the fourth compartment; the  
5 fourth compartment is sized to contain a waste bottle of the system; and the fourth door is configured such that, when enclosing the fourth compartment, the fourth door prevents the third door from opening to provide access to the third compartment.

10 18. The shielding assembly of Claim 17, wherein the third compartment extends approximately vertically along the third sidewall, on an opposite side of the third sidewall from the fourth compartment.

15 19. The shielding assembly of Claim 18, wherein the third compartment includes a retaining member to hold the other portion of the infusion circuit in place within the third compartment.

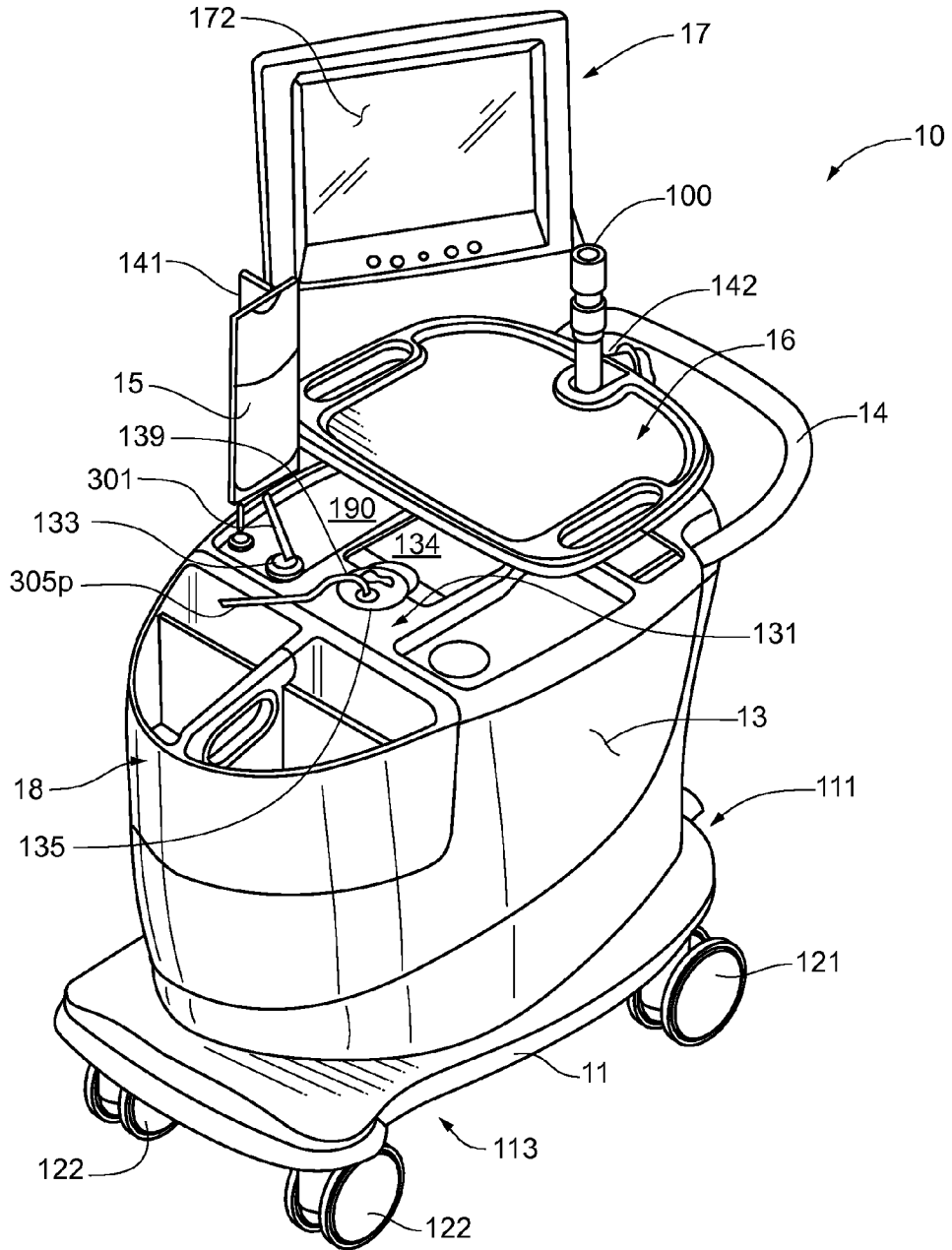
20. A system that generates and infuses radiopharmaceuticals, the system comprising a cabinet structure and , the shielding assembly of any one of Claims 1  
20 to 8, the cabinet structure including a shell that defines an interior space in which the shielding assembly is mounted, and wherein the shell of the cabinet structure includes a first upper opening and an upper surface; and the upper surface of the shell is located above, the first upper opening of the shell, the first upper opening being aligned with the first door and the opening of the first sidewall of the  
25 shielding assembly, in order to provide access thereto.

21. The system of Claim 20, wherein the upper surface of the shell of the cabinet structure includes a second upper opening, the second upper opening being aligned with the opening of the third sidewall of the shielding assembly.

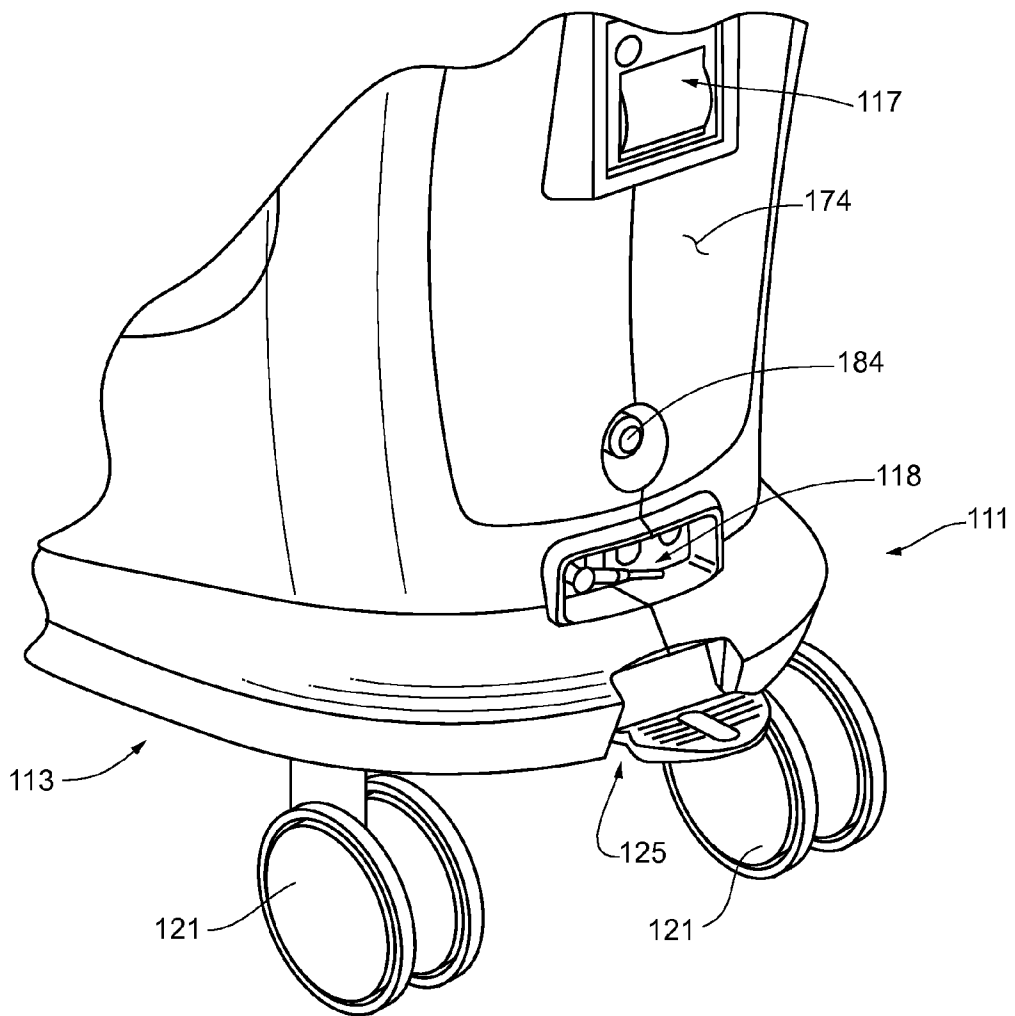
30

22. The system of Claim 20 or 21 wherein the first upper opening of the shell of the cabinet structure is configured to also provide access to the second door and the opening of the second sidewall of the shielding assembly.
- 5 23. The system of any one of claims 20 to 22, wherein the lid of the second sidewall of the shielding assembly is hinged to open in an upward direction; and the cabinet structure of the system further includes a framework and a latch component, the latch component being mounted to the framework to hold the lid of the second sidewall in an open position.

**Fig. 1A**

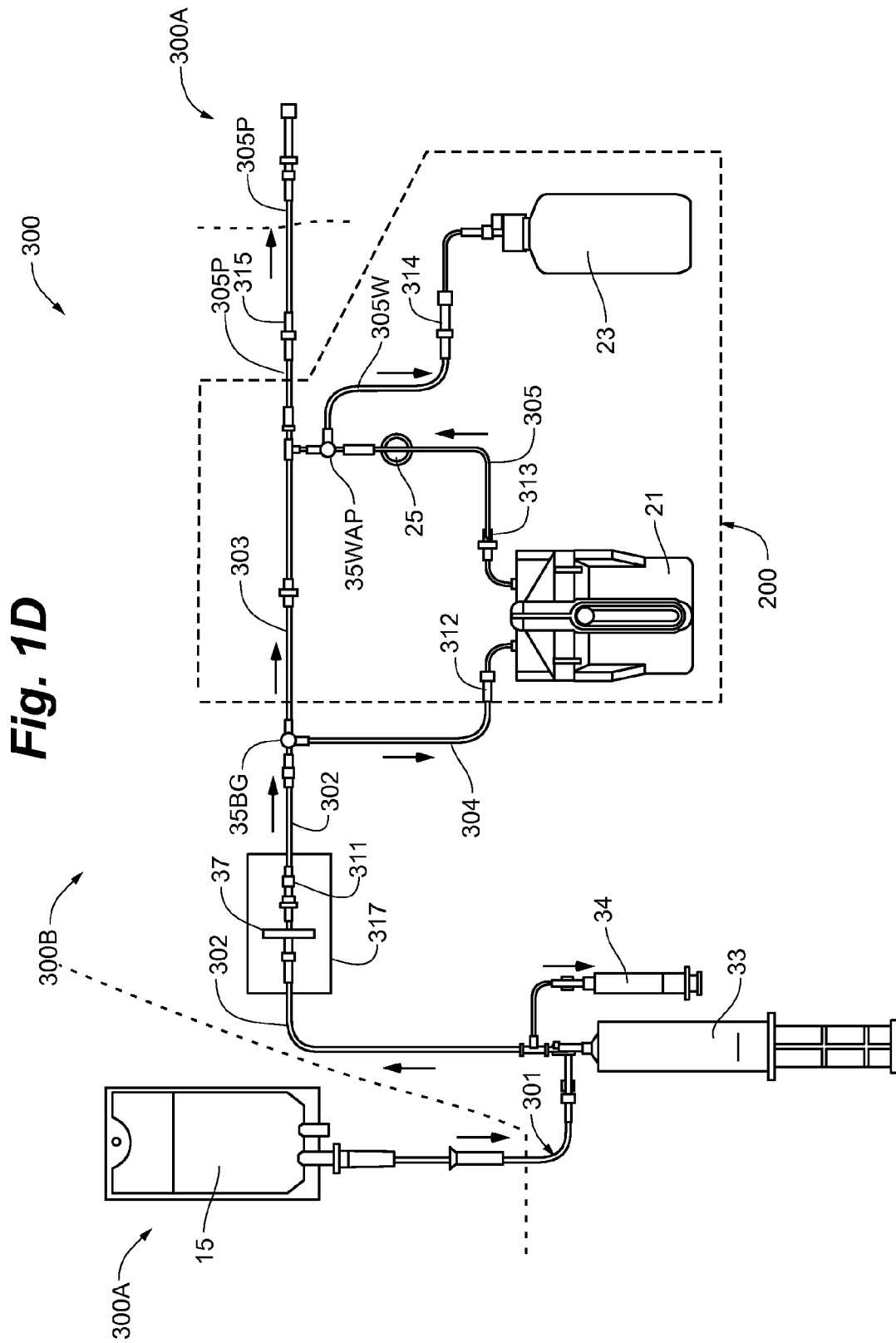


**Fig. 1B**





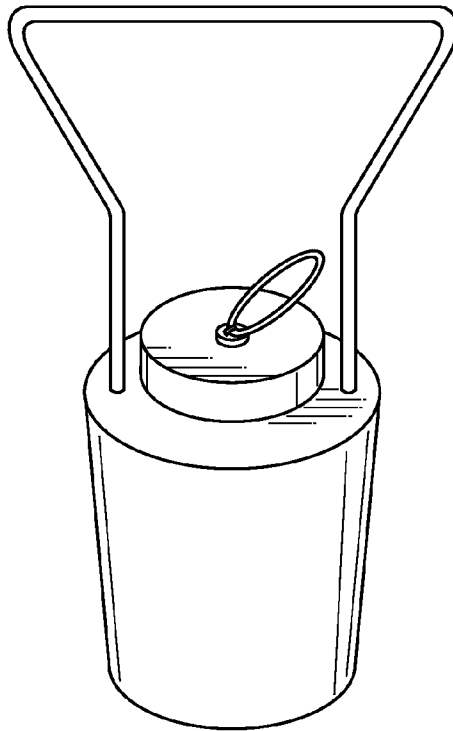




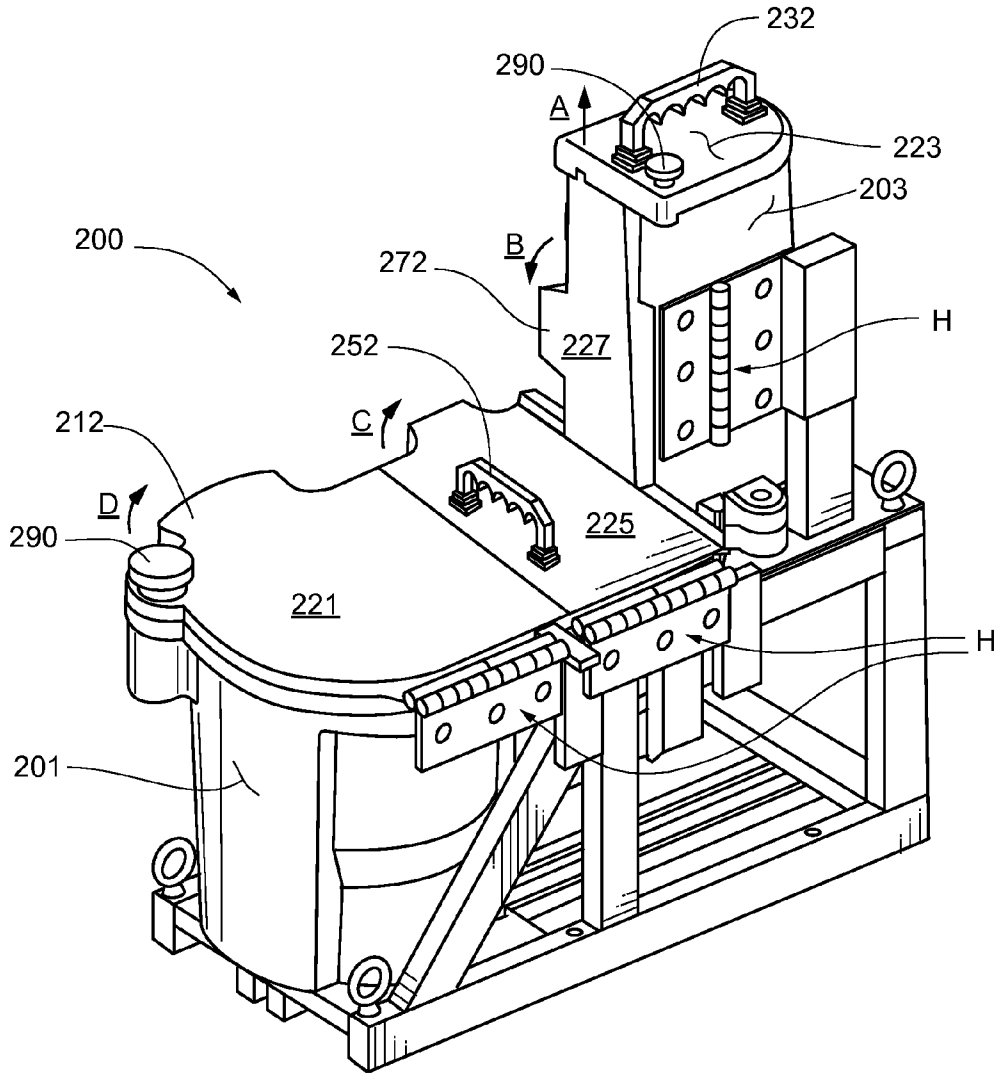
**Fig. 1D**

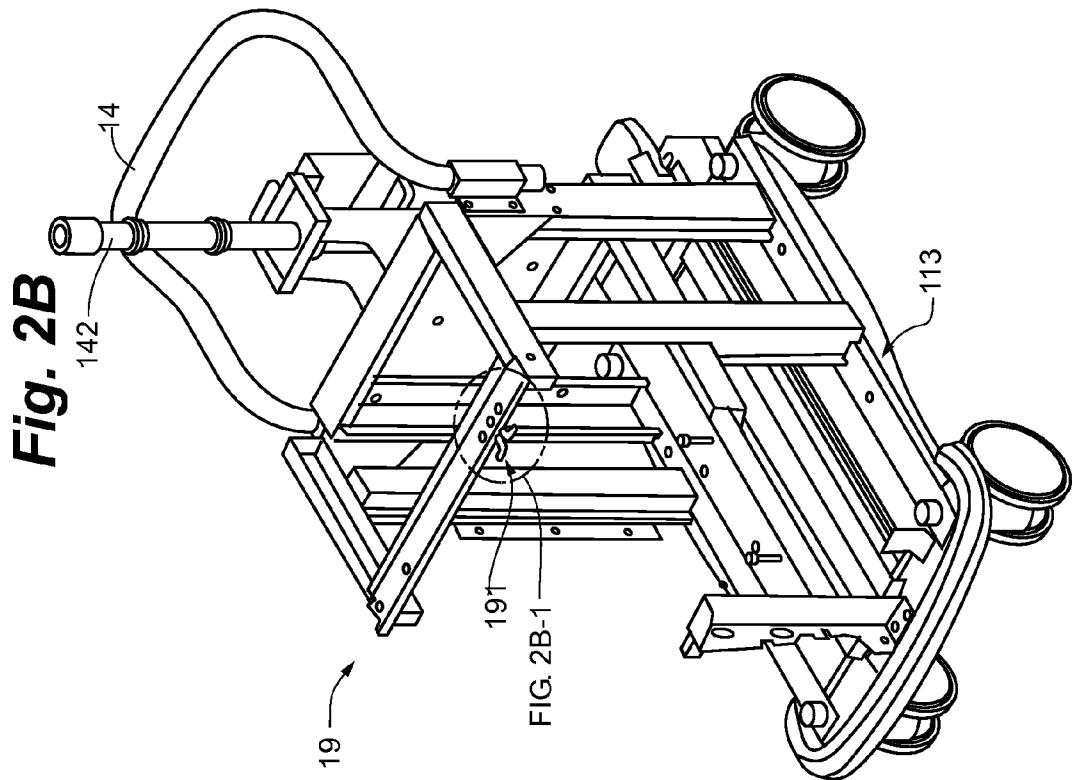
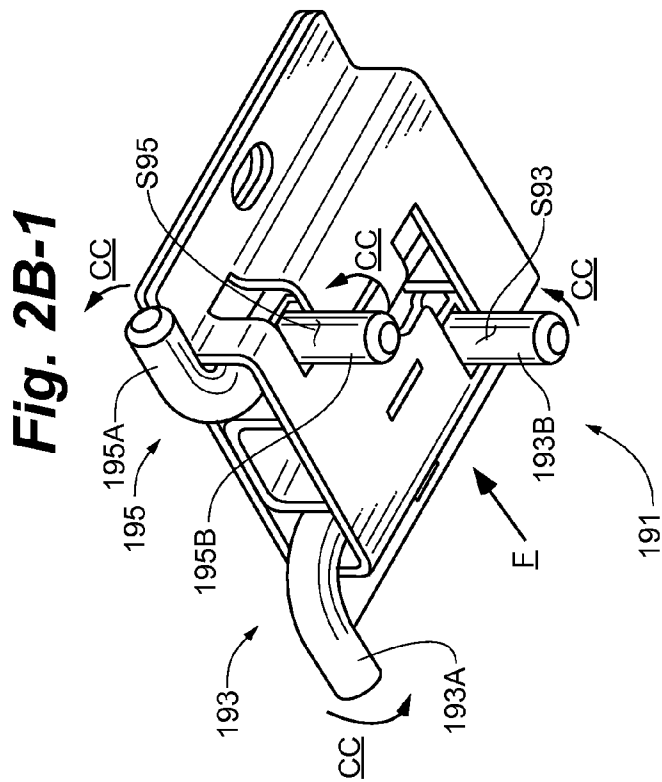
5/27

**Fig. 1E**

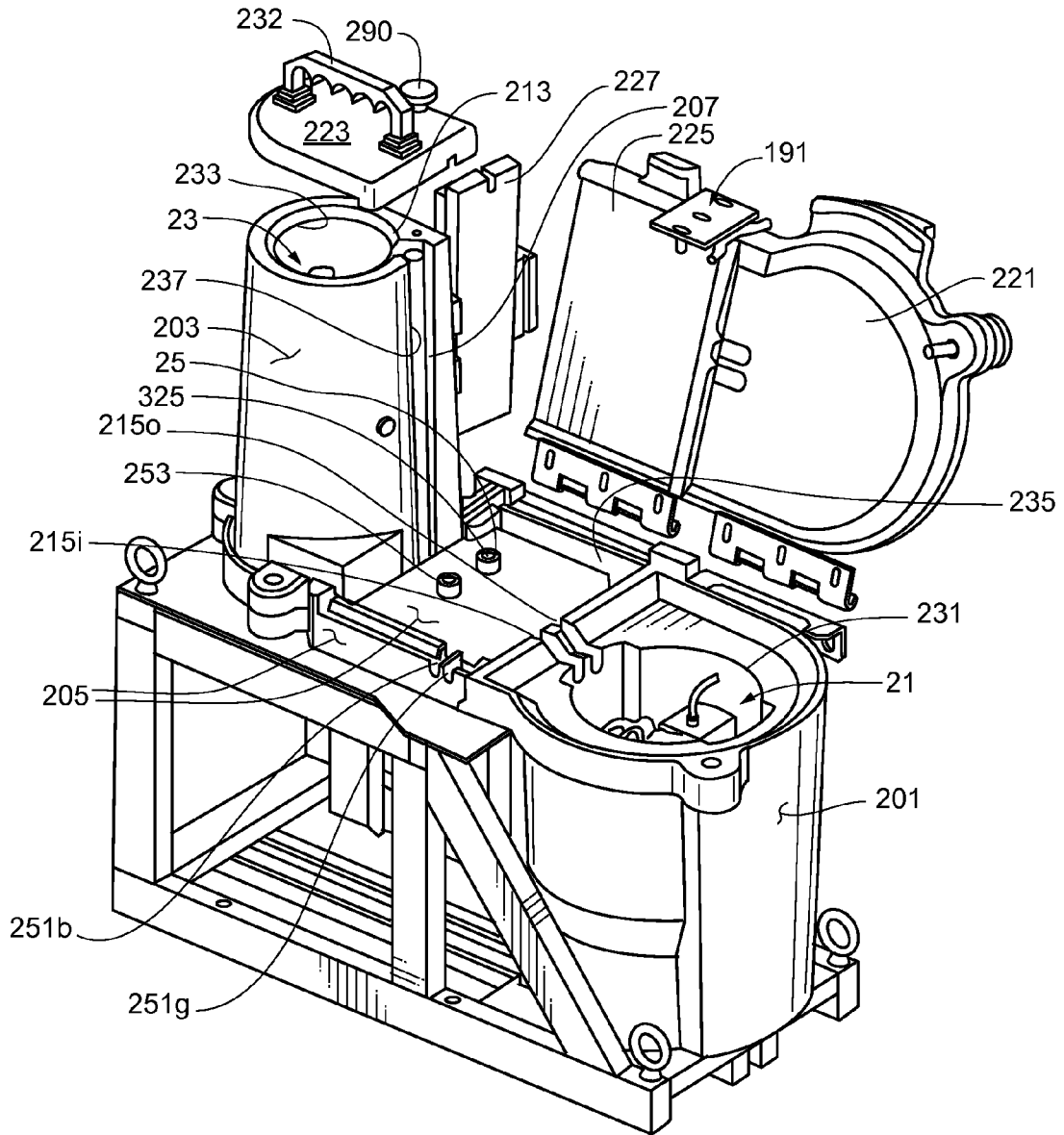


**Fig. 2A**





**Fig. 3A**



9/27

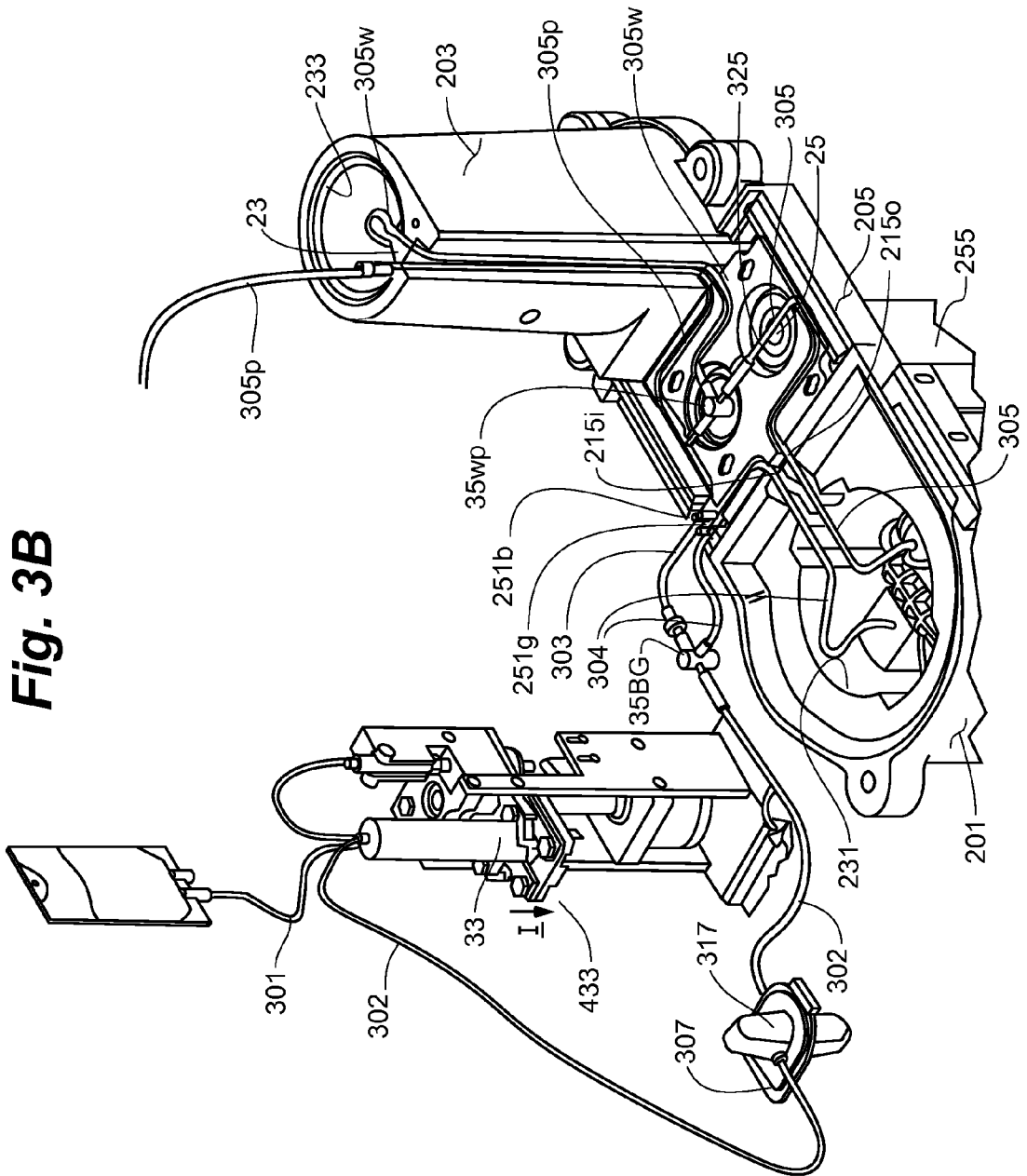
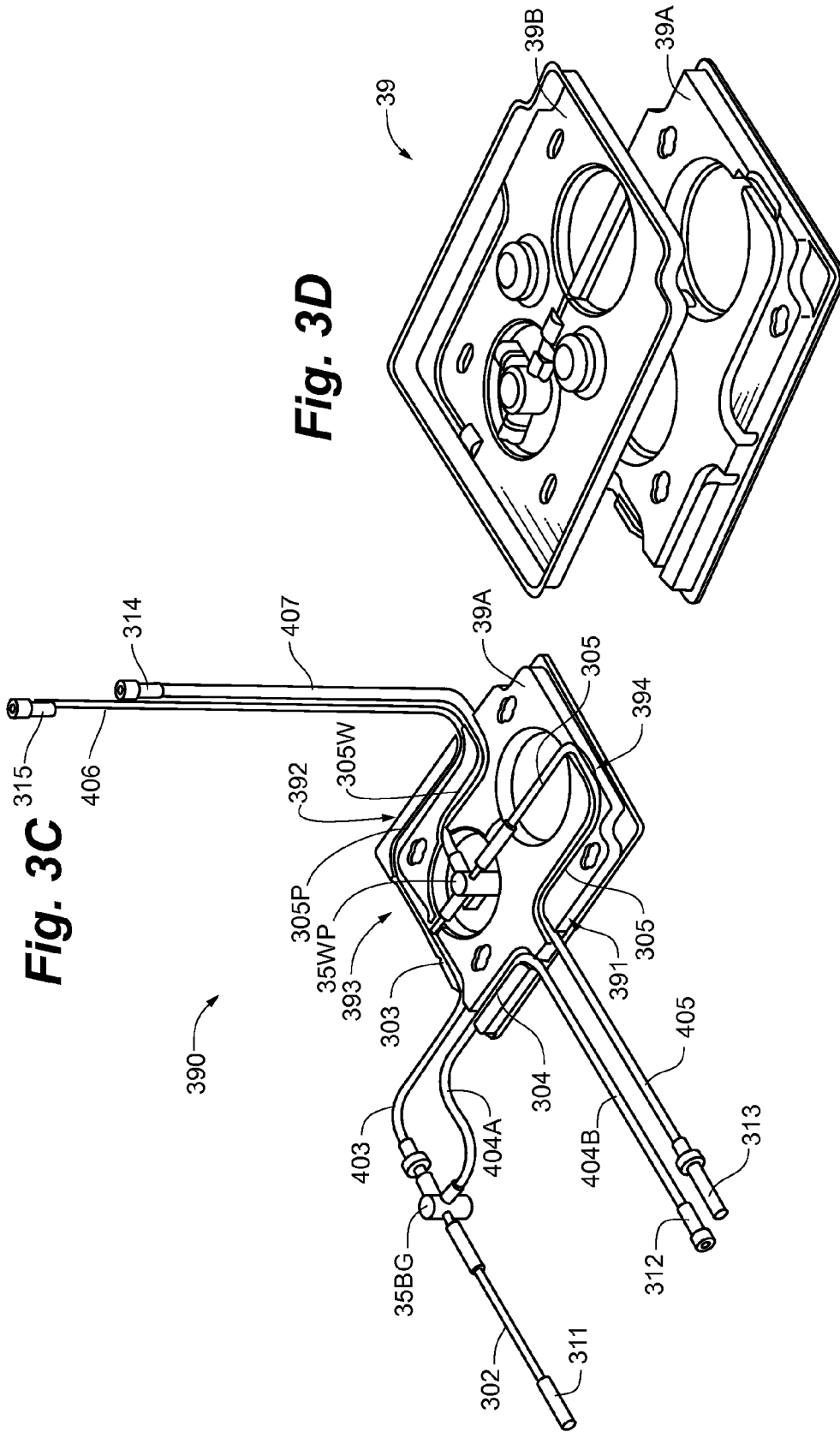


Fig. 3B

10/27



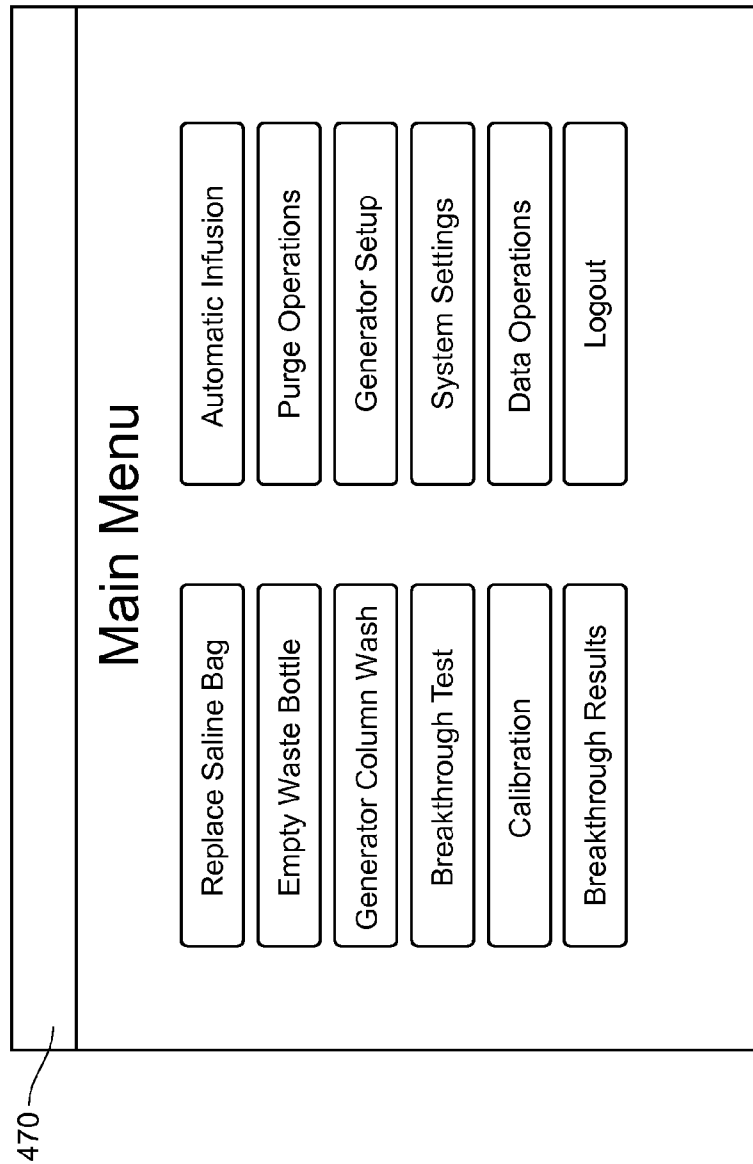
**Fig. 3C**

**Fig. 3D**



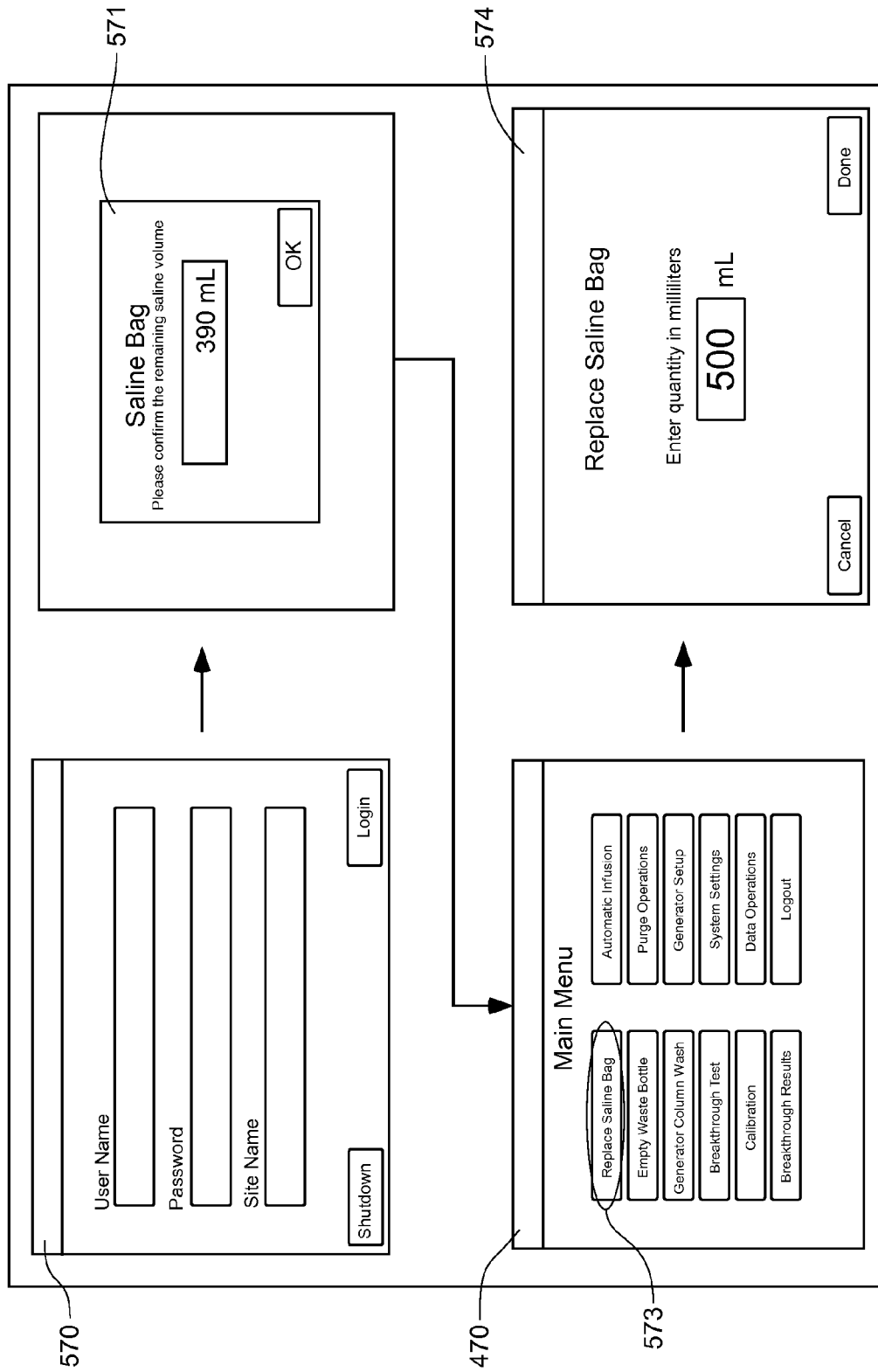
11/27

**Fig. 4**

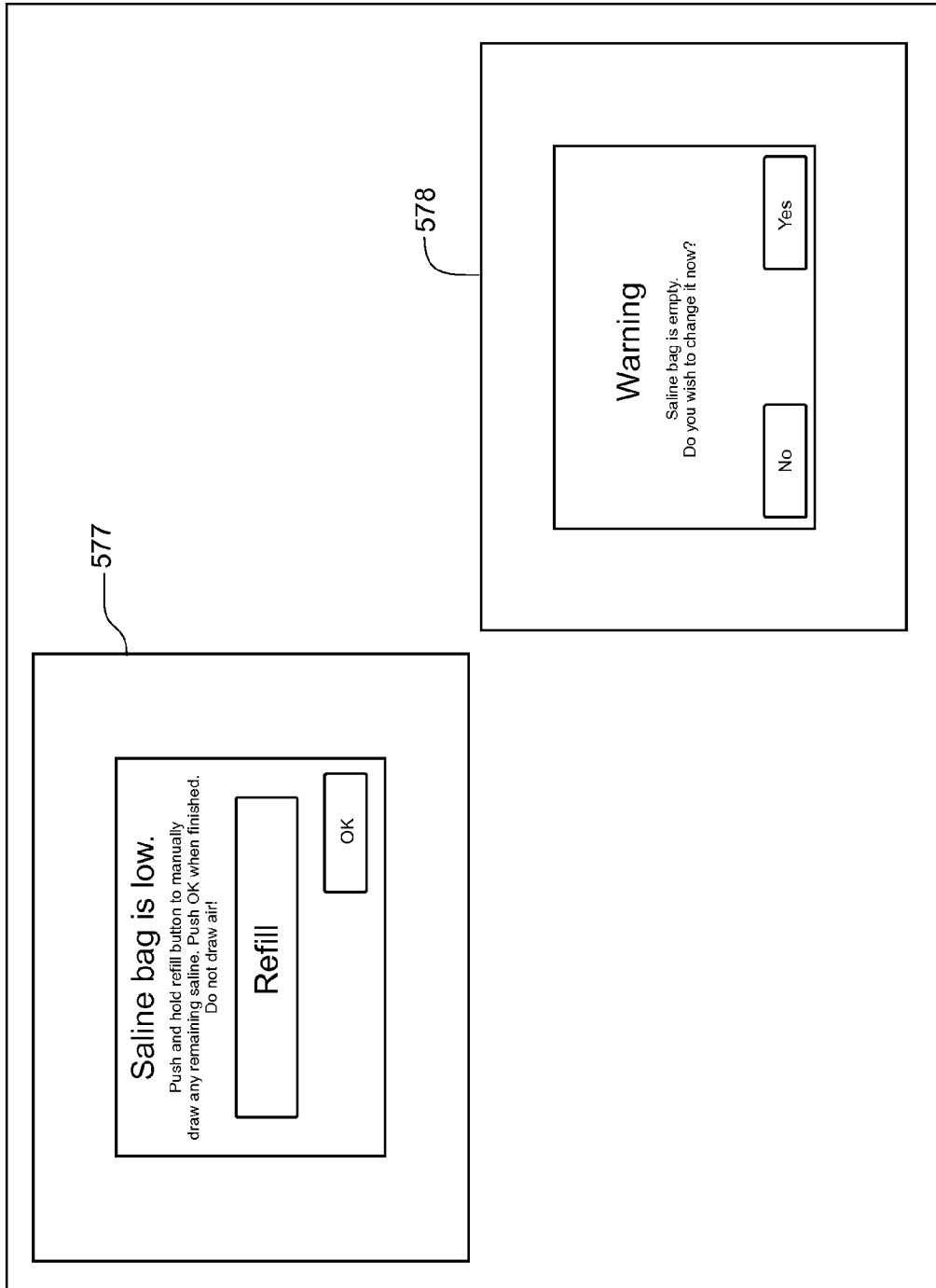


12/27

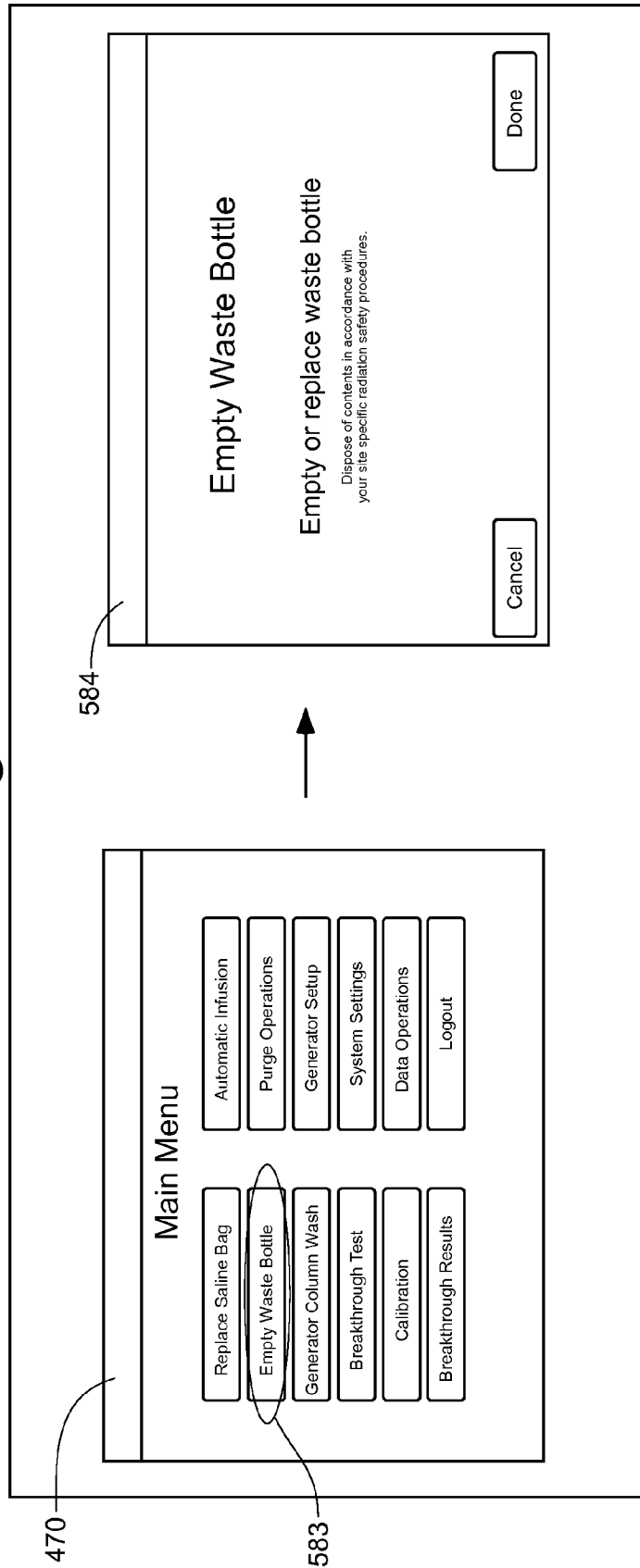
Fig. 5A

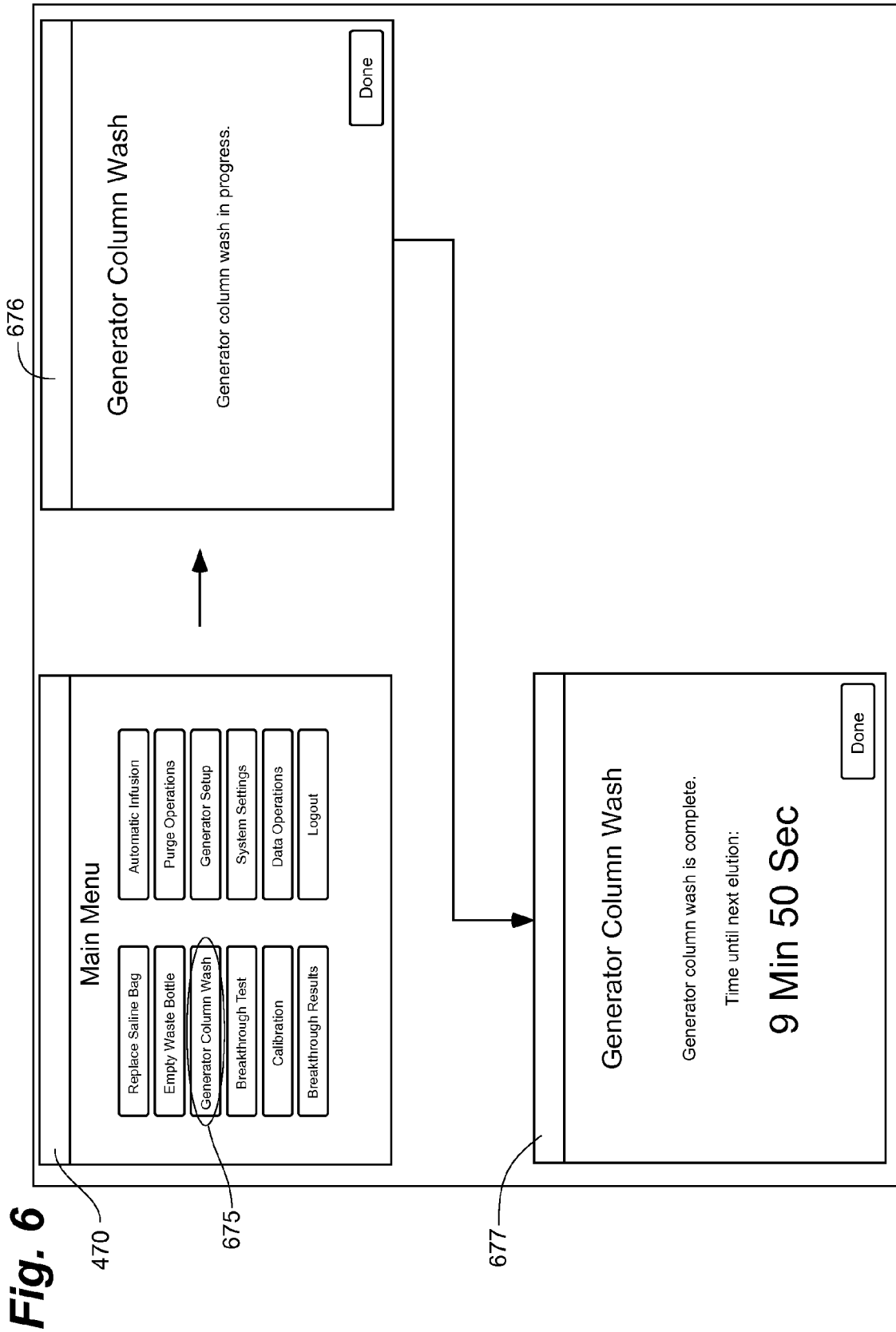


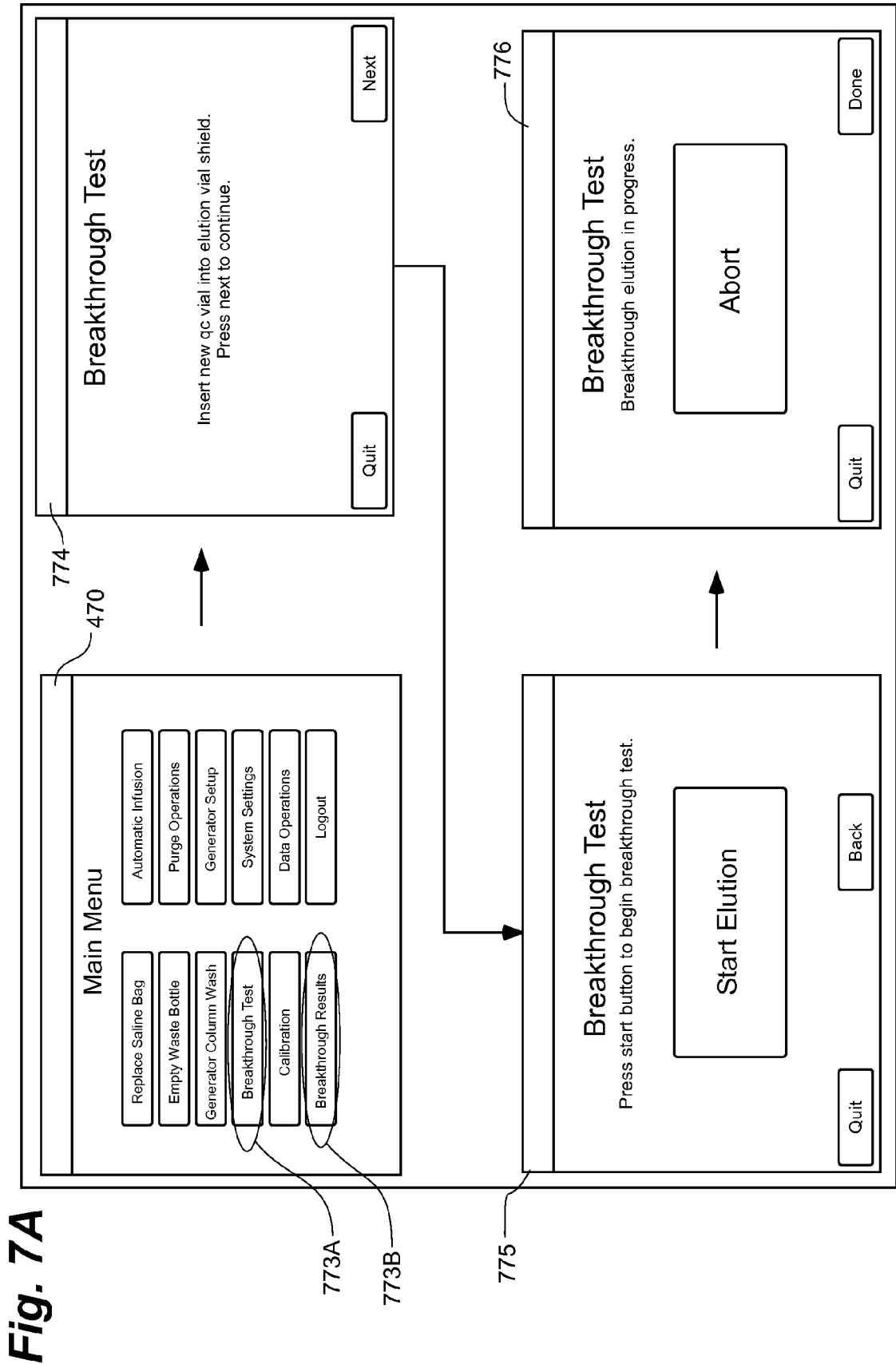
**Fig. 5B**



**Fig. 5C**







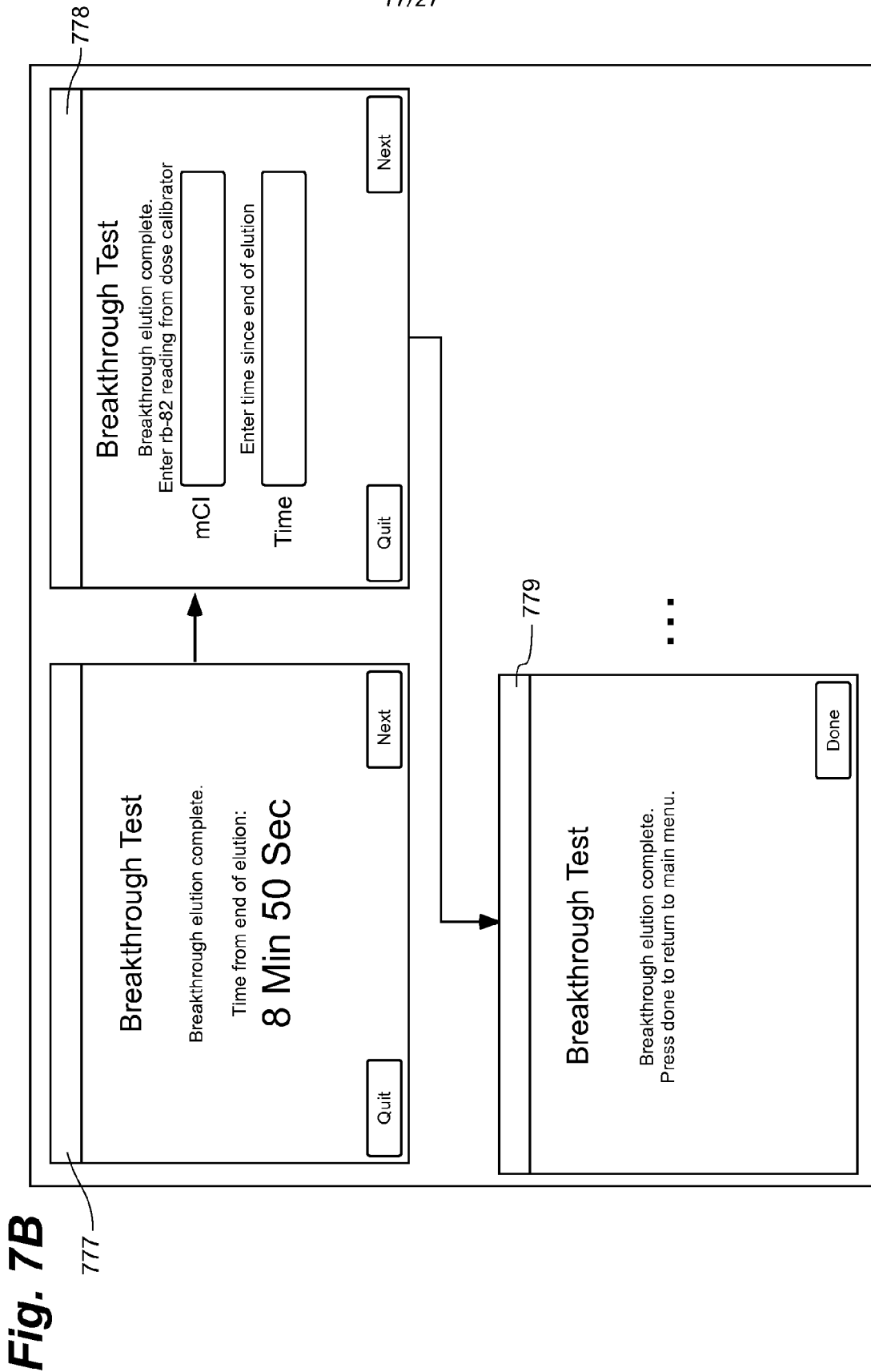
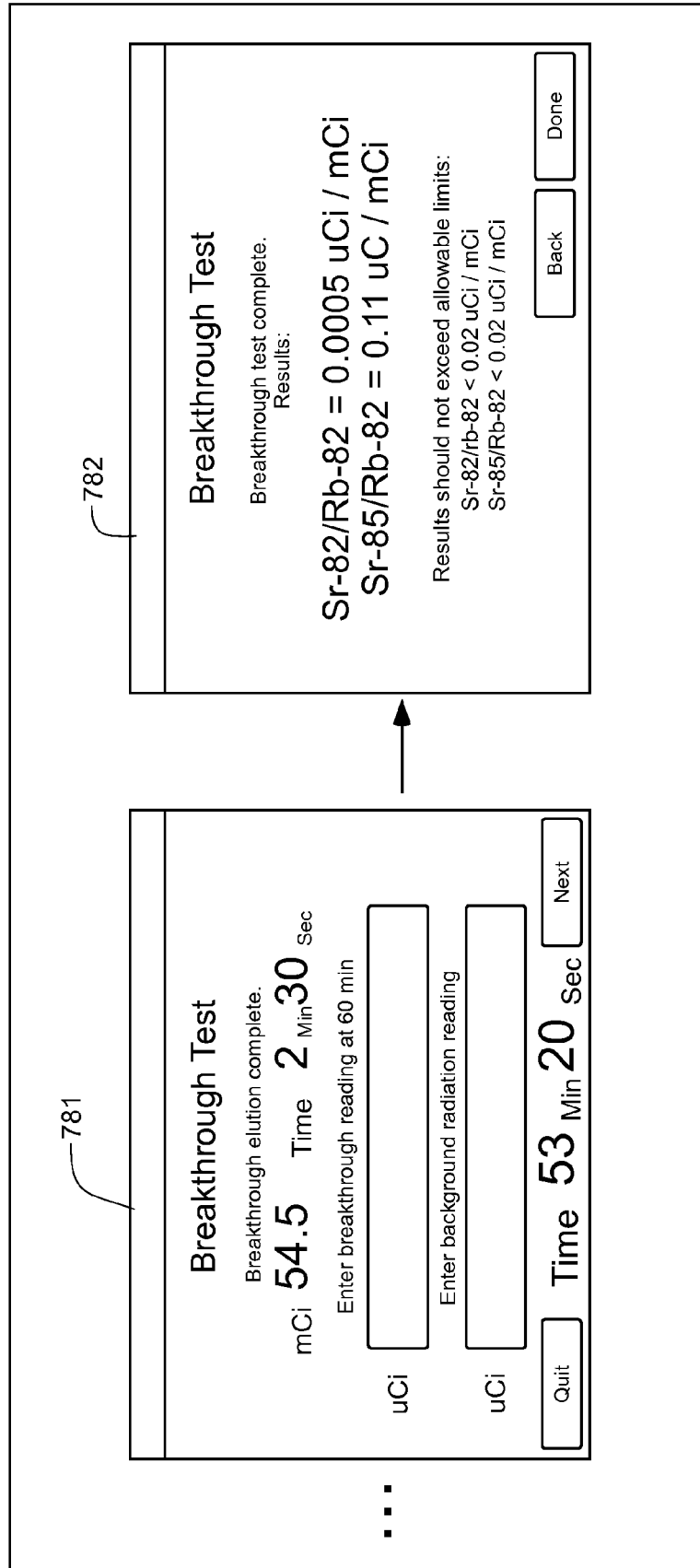
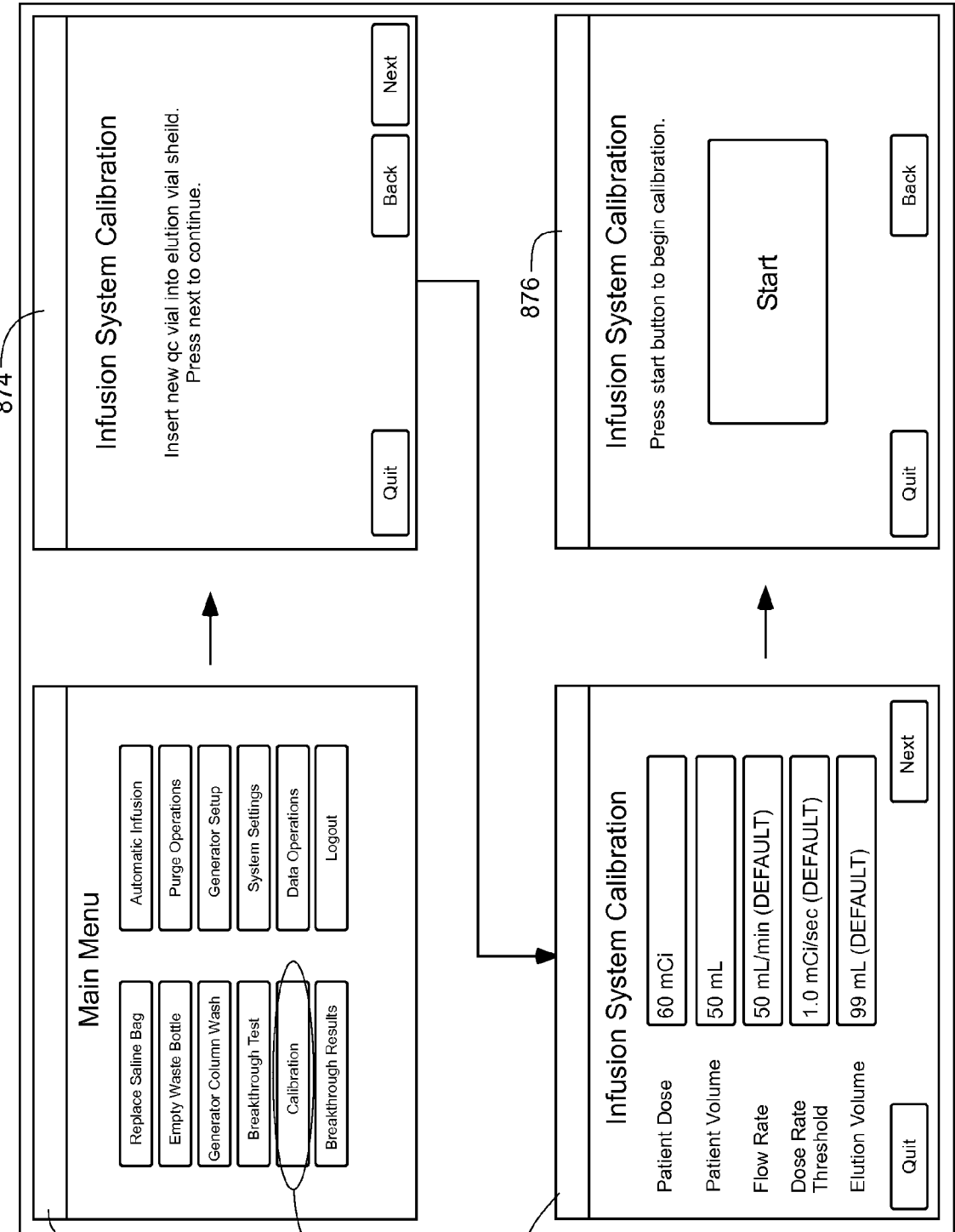


Fig. 7B

Fig. 7C







**Fig. 8A**

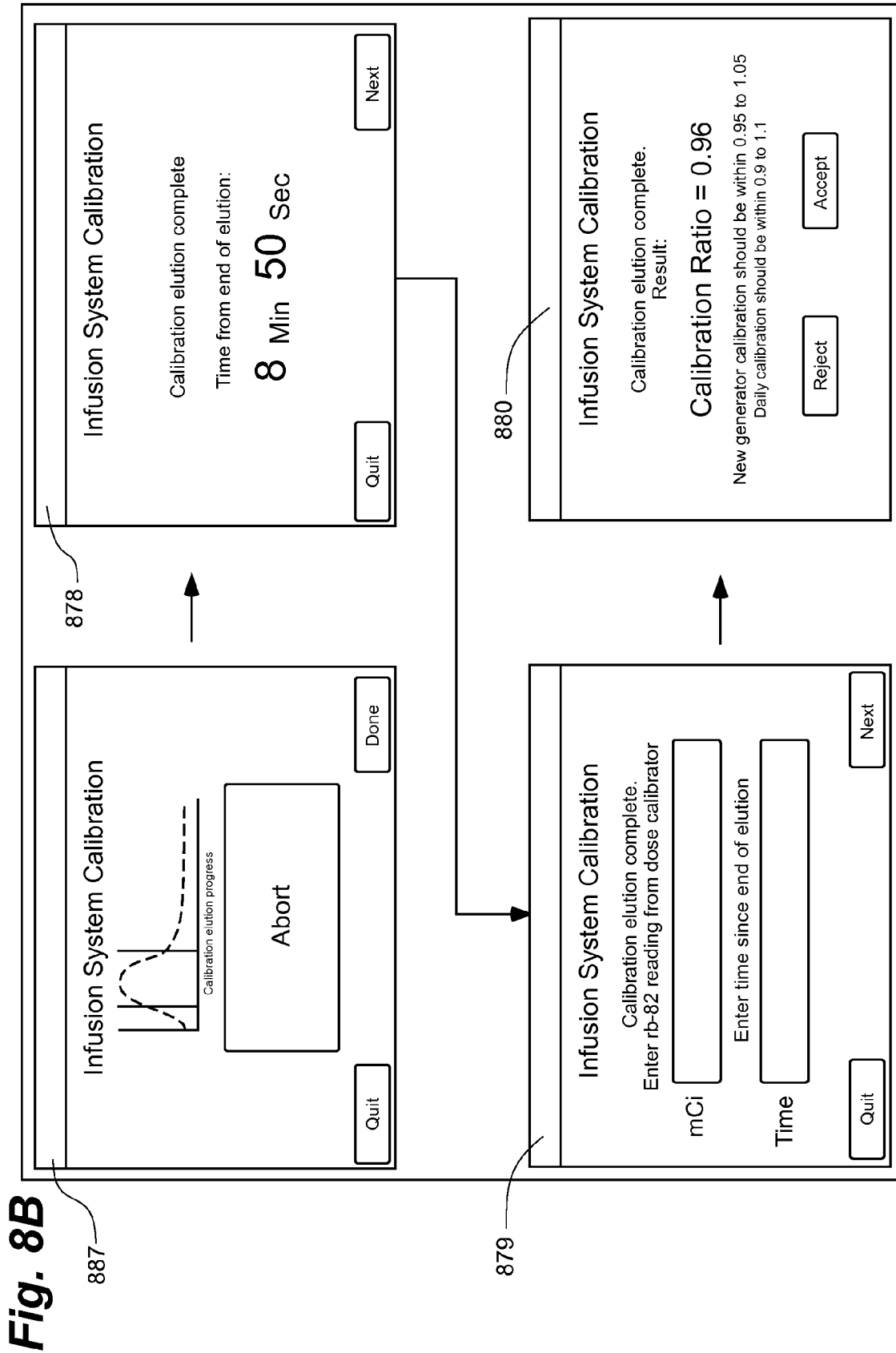
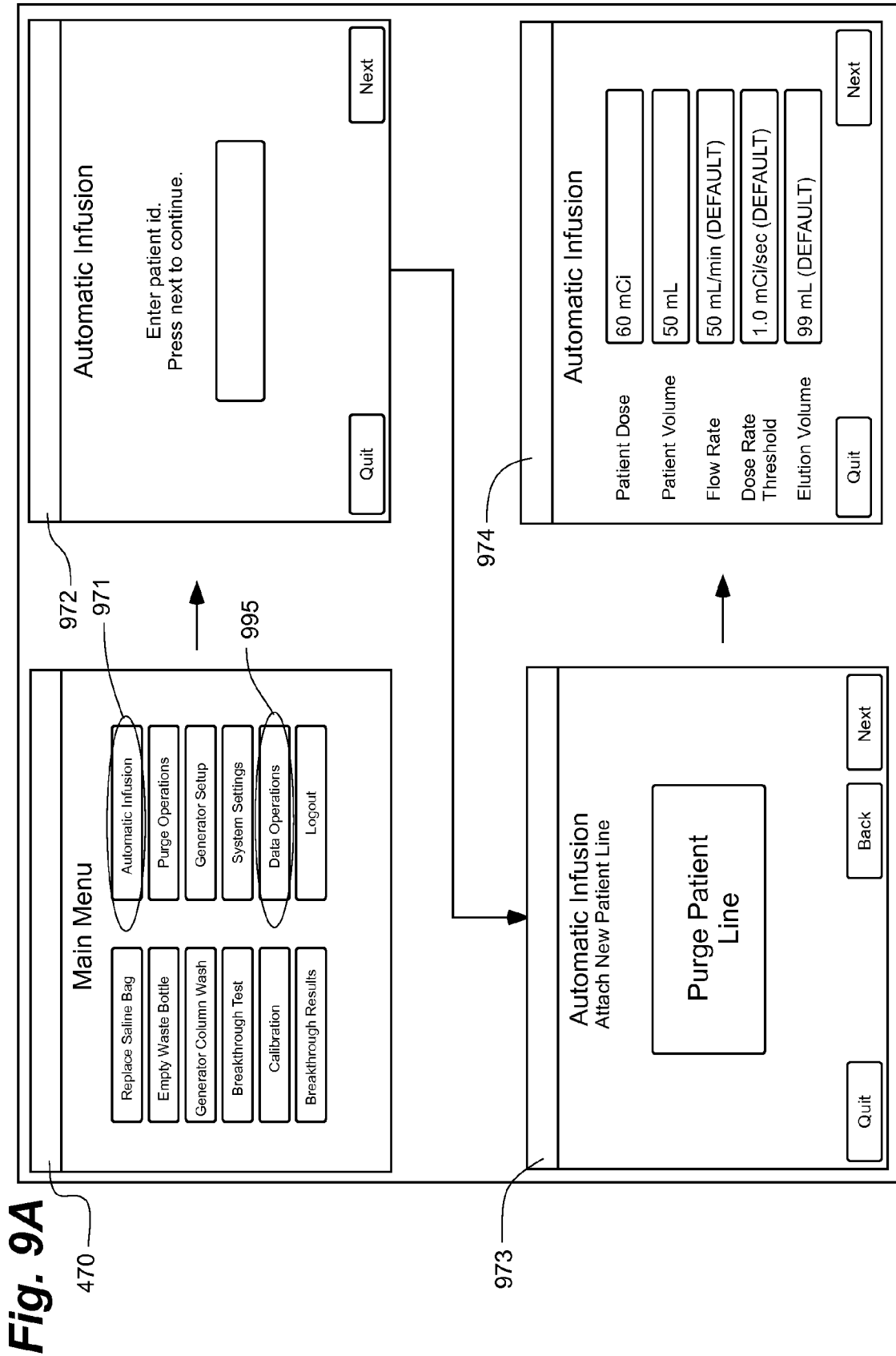


Fig. 8B



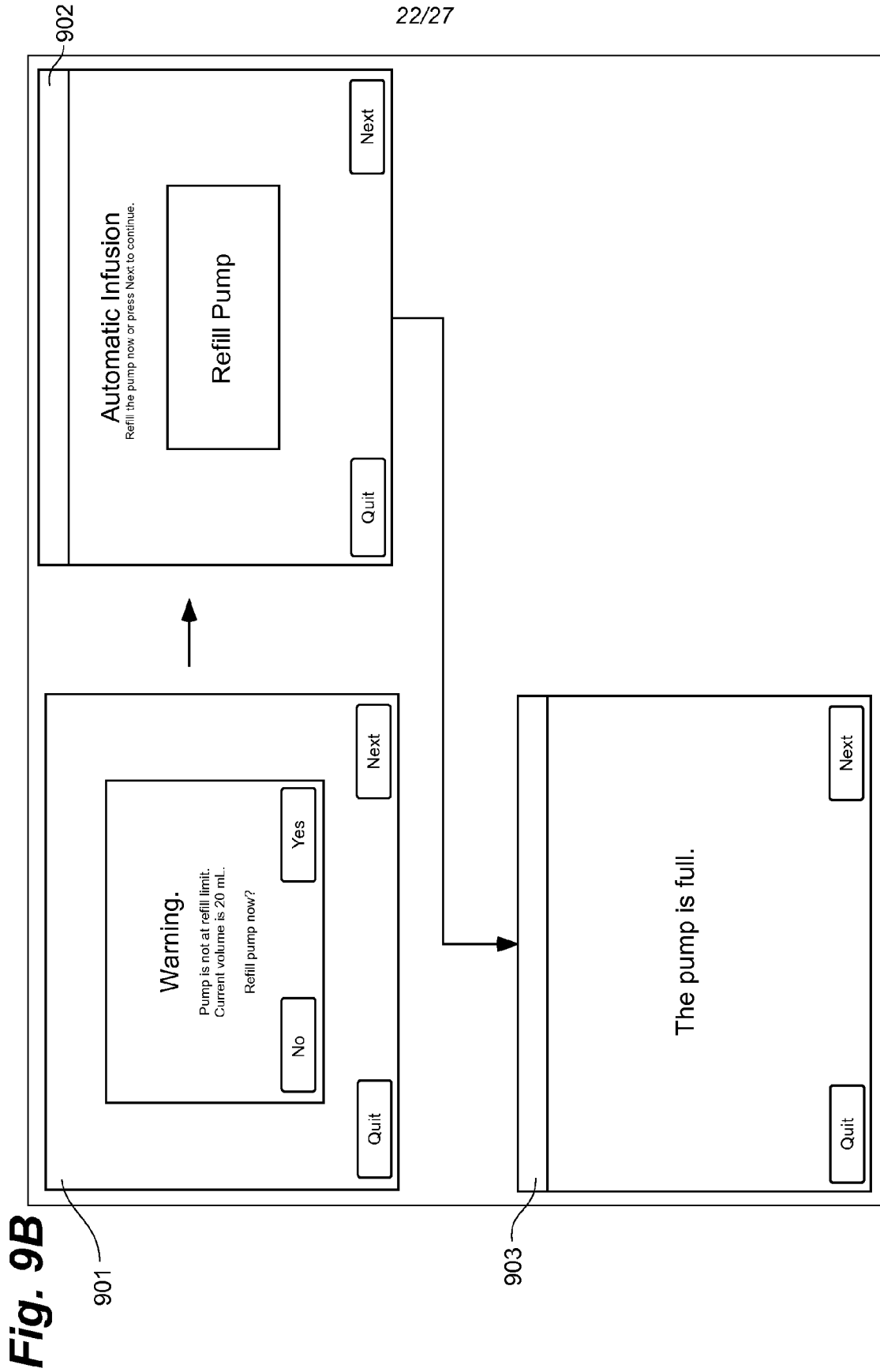


Fig. 9B

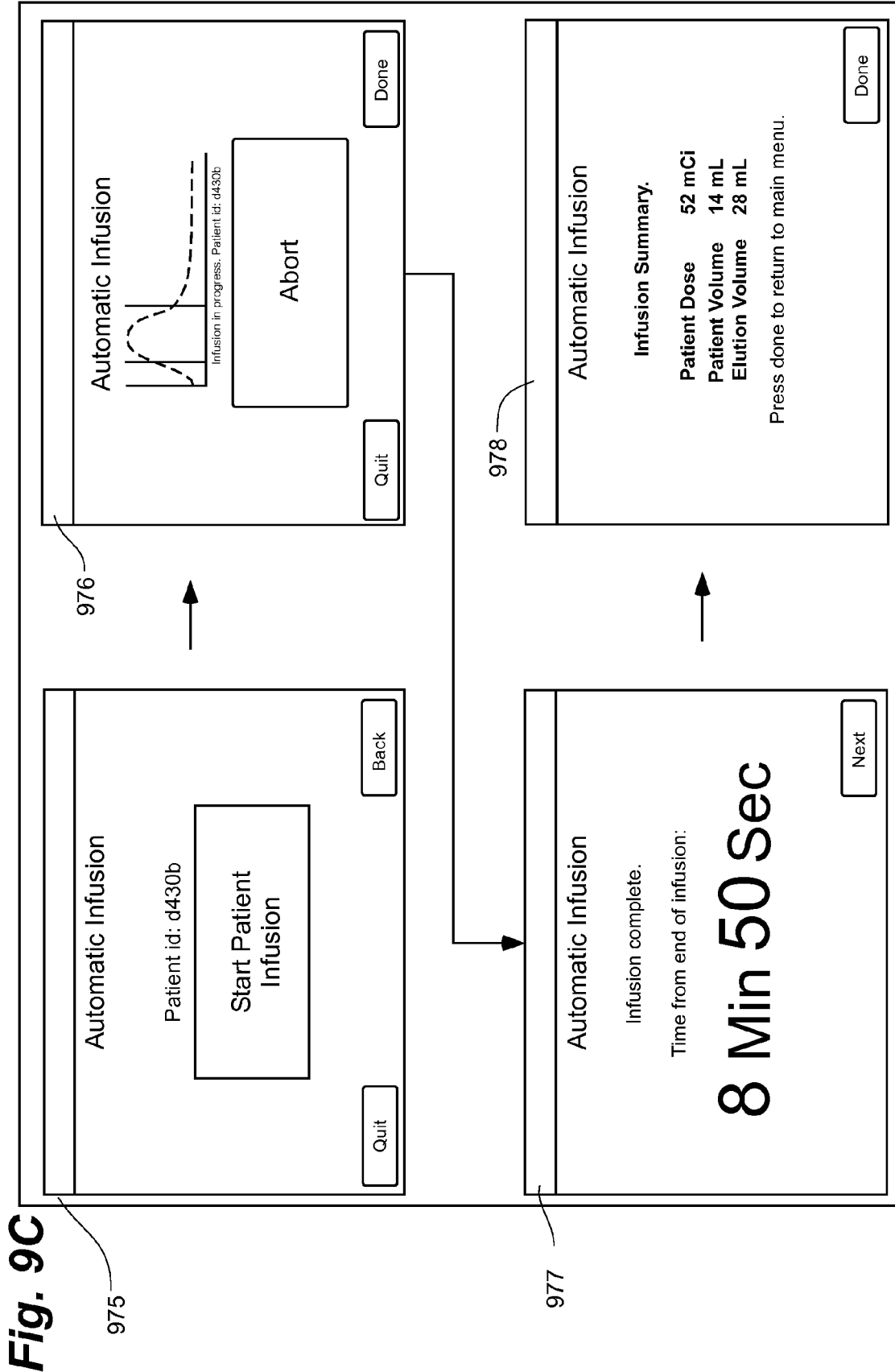


Fig. 9C

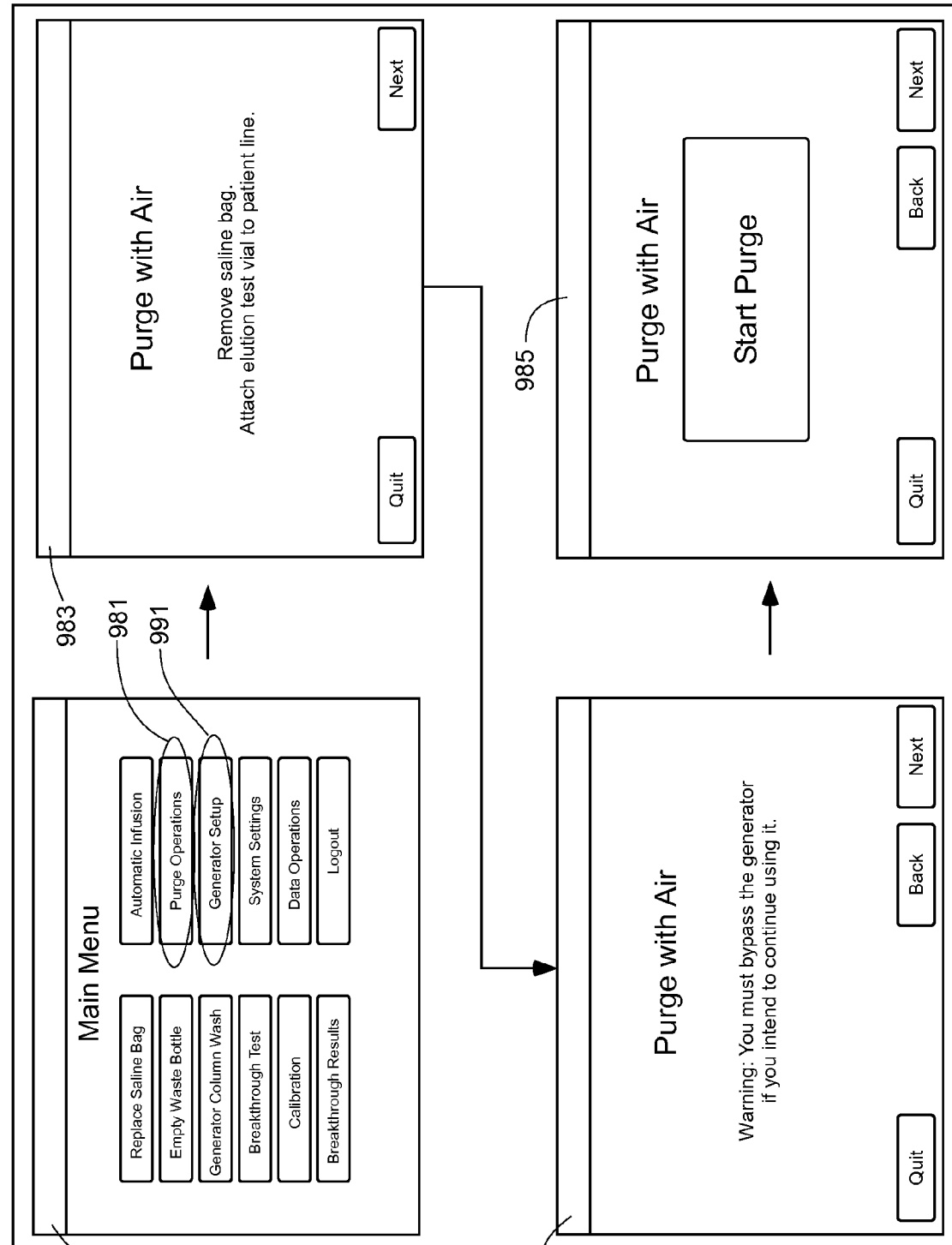


Fig. 10

470

984

983

981

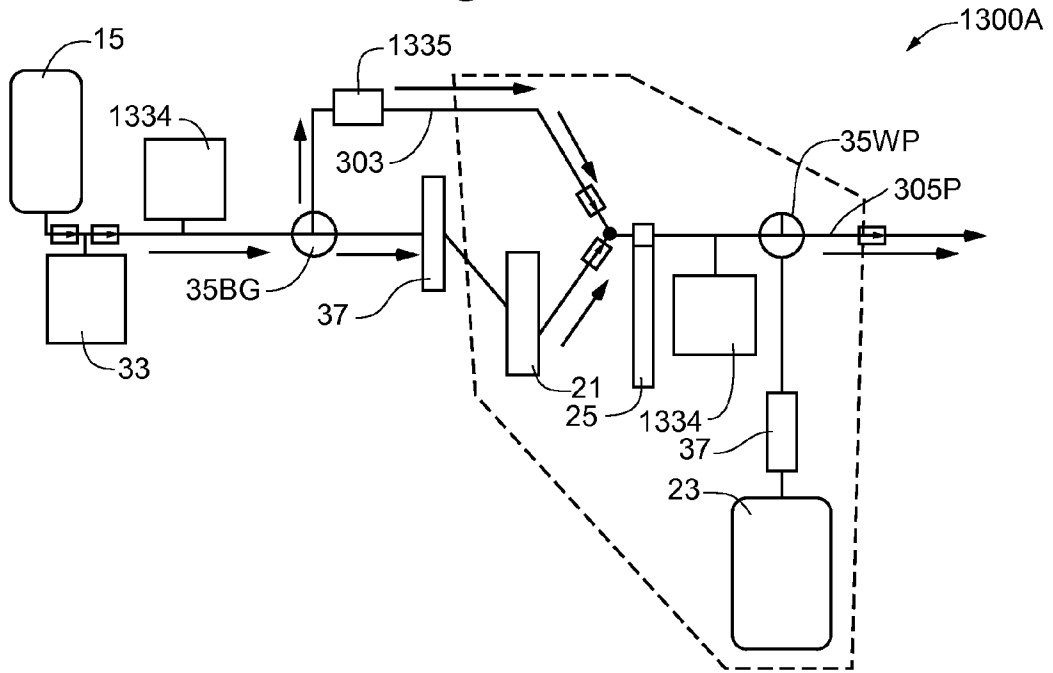
991

985

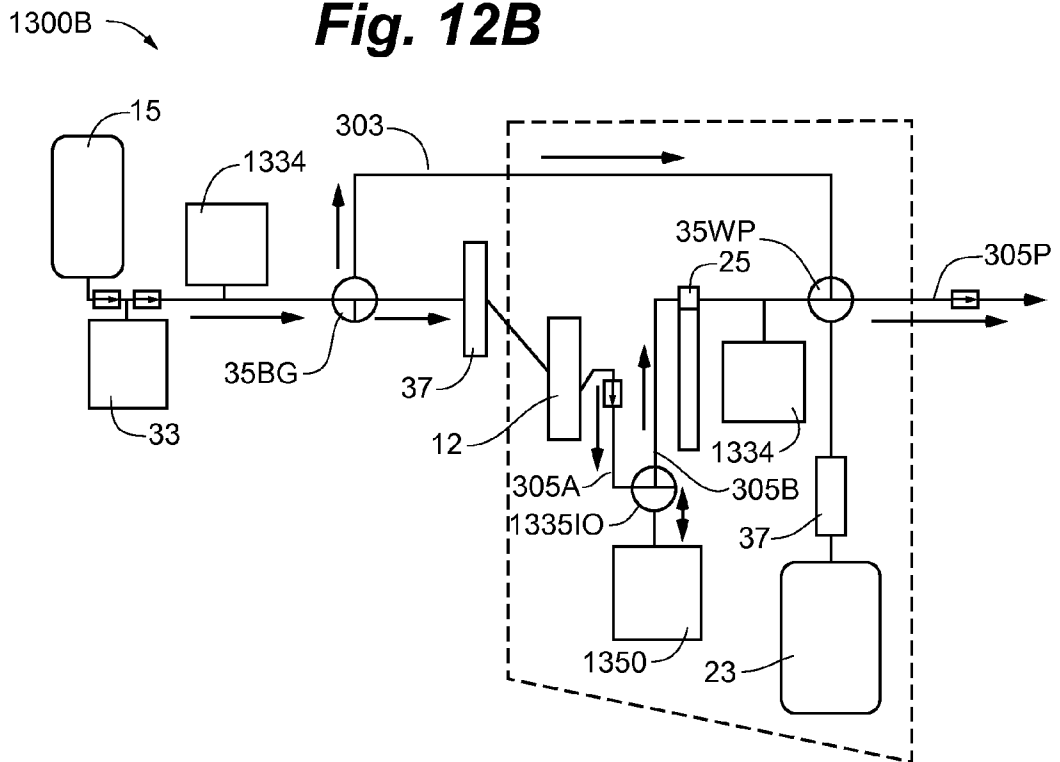
**Fig. 11**

<b>CARDIOGEN-82 GENERATOR MONTHLY RECEIPT/RETURN WORKSHEET</b>																							
<table border="1" style="width: 100%; border-collapse: collapse;"> <tr> <th colspan="2" style="text-align: center;">GENERATOR RECEIPT</th> </tr> <tr> <td style="padding: 2px;">DATE OF DELIVERY:</td> <td style="padding: 2px;">11/9/2008</td> </tr> <tr> <td style="padding: 2px;">DATE OF CALIBRATION:</td> <td style="padding: 2px;">11/10/2008</td> </tr> <tr> <td style="padding: 2px;">LOT NUMBER:</td> <td style="padding: 2px;"></td> </tr> <tr> <td style="padding: 2px;">Sr-82 ACTIVITY:</td> <td style="padding: 2px;">100 mCi</td> </tr> <tr> <td style="padding: 2px;">TOTAL ACTIVITY:</td> <td style="padding: 2px;">256 mCi</td> </tr> <tr> <td style="padding: 2px;">Sr-85 ACTIVITY:</td> <td style="padding: 2px;">156 mCi</td> </tr> </table>	GENERATOR RECEIPT		DATE OF DELIVERY:	11/9/2008	DATE OF CALIBRATION:	11/10/2008	LOT NUMBER:		Sr-82 ACTIVITY:	100 mCi	TOTAL ACTIVITY:	256 mCi	Sr-85 ACTIVITY:	156 mCi	<table border="1" style="width: 100%; border-collapse: collapse;"> <tr> <th colspan="2" style="text-align: center;">RECEIPT SURVEY</th> </tr> <tr> <td style="padding: 2px;">SURFACE:</td> <td style="padding: 2px;">10.0 mrem/hr (MUST BE &lt; 50 mrem/hr)</td> </tr> <tr> <td style="padding: 2px;">1 METER:</td> <td style="padding: 2px;">0.6 mrem/hr (MUST BE &lt; 1 mrem/hr)</td> </tr> <tr> <td style="padding: 2px;">SURFACE WIPE:</td> <td style="padding: 2px;">1599 dpm (MUST BE &lt; 2200 dpm/100 cm<sup>2</sup>)</td> </tr> </table>	RECEIPT SURVEY		SURFACE:	10.0 mrem/hr (MUST BE < 50 mrem/hr)	1 METER:	0.6 mrem/hr (MUST BE < 1 mrem/hr)	SURFACE WIPE:	1599 dpm (MUST BE < 2200 dpm/100 cm <sup>2</sup> )
GENERATOR RECEIPT																							
DATE OF DELIVERY:	11/9/2008																						
DATE OF CALIBRATION:	11/10/2008																						
LOT NUMBER:																							
Sr-82 ACTIVITY:	100 mCi																						
TOTAL ACTIVITY:	256 mCi																						
Sr-85 ACTIVITY:	156 mCi																						
RECEIPT SURVEY																							
SURFACE:	10.0 mrem/hr (MUST BE < 50 mrem/hr)																						
1 METER:	0.6 mrem/hr (MUST BE < 1 mrem/hr)																						
SURFACE WIPE:	1599 dpm (MUST BE < 2200 dpm/100 cm <sup>2</sup> )																						
<table border="1" style="width: 100%; border-collapse: collapse;"> <tr> <th colspan="2" style="text-align: center;">GENERATOR RETURN</th> </tr> <tr> <td style="padding: 2px;">DATE OF RETURN:</td> <td style="padding: 2px;">12/27/2008</td> </tr> <tr> <td style="padding: 2px;">DAYS SINCE CALIBRATION DATE:</td> <td style="padding: 2px;">47</td> </tr> </table>	GENERATOR RETURN		DATE OF RETURN:	12/27/2008	DAYS SINCE CALIBRATION DATE:	47	<table border="1" style="width: 100%; border-collapse: collapse;"> <tr> <th colspan="2" style="text-align: center;">RETURN SURVEY</th> </tr> <tr> <td style="padding: 2px;">SURFACE:</td> <td style="padding: 2px;">5.6 mrem/hr (MUST BE &lt; 50 mrem/hr)</td> </tr> <tr> <td style="padding: 2px;">1 METER:</td> <td style="padding: 2px;">0.2 mrem/hr (MUST BE &lt; 1 mrem/hr)</td> </tr> <tr> <td style="padding: 2px;">SURFACE WIPE:</td> <td style="padding: 2px;">1278 dpm (MUST BE &lt; 2200 dpm/100 cm<sup>2</sup>)</td> </tr> </table>	RETURN SURVEY		SURFACE:	5.6 mrem/hr (MUST BE < 50 mrem/hr)	1 METER:	0.2 mrem/hr (MUST BE < 1 mrem/hr)	SURFACE WIPE:	1278 dpm (MUST BE < 2200 dpm/100 cm <sup>2</sup> )								
GENERATOR RETURN																							
DATE OF RETURN:	12/27/2008																						
DAYS SINCE CALIBRATION DATE:	47																						
RETURN SURVEY																							
SURFACE:	5.6 mrem/hr (MUST BE < 50 mrem/hr)																						
1 METER:	0.2 mrem/hr (MUST BE < 1 mrem/hr)																						
SURFACE WIPE:	1278 dpm (MUST BE < 2200 dpm/100 cm <sup>2</sup> )																						
<table border="1" style="width: 100%; border-collapse: collapse;"> <tr> <th colspan="2" style="text-align: center;">Sr-82 RETURN CALCULATIONS</th> </tr> <tr> <td style="padding: 2px;">INITIAL Sr-82 ACTIVITY:</td> <td style="padding: 2px;">100 mCi</td> </tr> <tr> <td style="padding: 2px;">DECAY FACTOR:</td> <td style="padding: 2px;">0.2718</td> </tr> <tr> <td style="padding: 2px;">REMAINING Sr-82 IN mCi:</td> <td style="padding: 2px;">27.18 mCi</td> </tr> <tr> <td style="padding: 2px;">REMAINING Sr-82 IN GBq:</td> <td style="padding: 2px;">1.01 GBq</td> </tr> </table>	Sr-82 RETURN CALCULATIONS		INITIAL Sr-82 ACTIVITY:	100 mCi	DECAY FACTOR:	0.2718	REMAINING Sr-82 IN mCi:	27.18 mCi	REMAINING Sr-82 IN GBq:	1.01 GBq	<table border="1" style="width: 100%; border-collapse: collapse;"> <tr> <th colspan="2" style="text-align: center;">SUMMARY</th> </tr> <tr> <td style="padding: 2px;">TOTAL Sr-82/Sr-85 ACTIVITY:</td> <td style="padding: 2px;">120.95 mCi</td> </tr> <tr> <td style="padding: 2px;">TOTAL Sr-82/Sr-85 ACTIVITY:</td> <td style="padding: 2px;">4.48 GBq</td> </tr> <tr> <td style="padding: 2px;">TRANSPORT INDEX:</td> <td style="padding: 2px;">0.2</td> </tr> </table>	SUMMARY		TOTAL Sr-82/Sr-85 ACTIVITY:	120.95 mCi	TOTAL Sr-82/Sr-85 ACTIVITY:	4.48 GBq	TRANSPORT INDEX:	0.2				
Sr-82 RETURN CALCULATIONS																							
INITIAL Sr-82 ACTIVITY:	100 mCi																						
DECAY FACTOR:	0.2718																						
REMAINING Sr-82 IN mCi:	27.18 mCi																						
REMAINING Sr-82 IN GBq:	1.01 GBq																						
SUMMARY																							
TOTAL Sr-82/Sr-85 ACTIVITY:	120.95 mCi																						
TOTAL Sr-82/Sr-85 ACTIVITY:	4.48 GBq																						
TRANSPORT INDEX:	0.2																						
<table border="1" style="width: 100%; border-collapse: collapse;"> <tr> <th colspan="2" style="text-align: center;">Sr-85 RETURN CALCULATIONS</th> </tr> <tr> <td style="padding: 2px;">INITIAL Sr-85 ACTIVITY:</td> <td style="padding: 2px;">156 mCi</td> </tr> <tr> <td style="padding: 2px;">DECAY FACTOR:</td> <td style="padding: 2px;">0.6011</td> </tr> <tr> <td style="padding: 2px;">REMAINING Sr-85 IN mCi:</td> <td style="padding: 2px;">93.77 mCi</td> </tr> <tr> <td style="padding: 2px;">REMAINING Sr-85 IN GBq:</td> <td style="padding: 2px;">3.47 GBq</td> </tr> </table>	Sr-85 RETURN CALCULATIONS		INITIAL Sr-85 ACTIVITY:	156 mCi	DECAY FACTOR:	0.6011	REMAINING Sr-85 IN mCi:	93.77 mCi	REMAINING Sr-85 IN GBq:	3.47 GBq													
Sr-85 RETURN CALCULATIONS																							
INITIAL Sr-85 ACTIVITY:	156 mCi																						
DECAY FACTOR:	0.6011																						
REMAINING Sr-85 IN mCi:	93.77 mCi																						
REMAINING Sr-85 IN GBq:	3.47 GBq																						

**Fig. 12A**



**Fig. 12B**





**Fig. 12C**

