

L. P. HARRIS.
Grain Binder.

No. 31,540.

Patented Feb. 26, 1861.

Fig. 4,

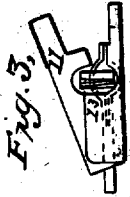
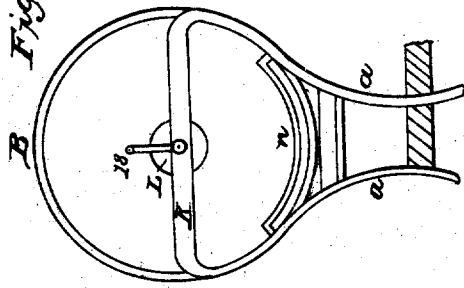

Fig. 2,

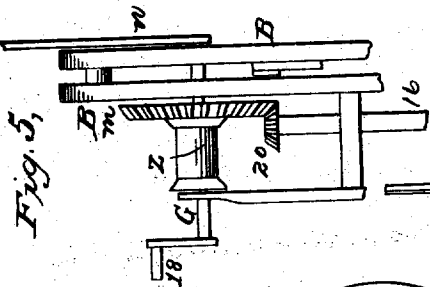
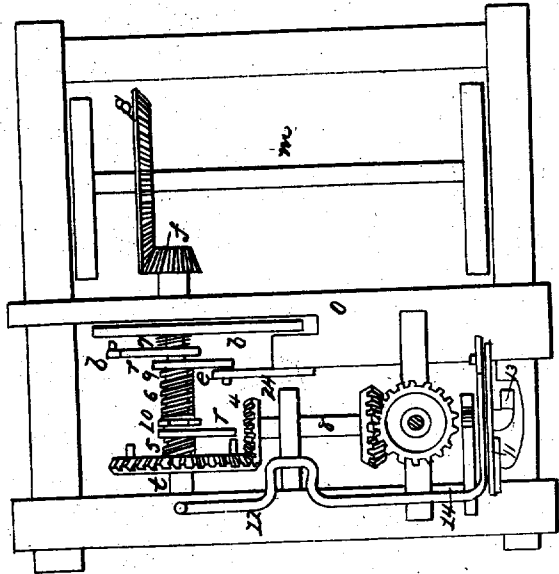
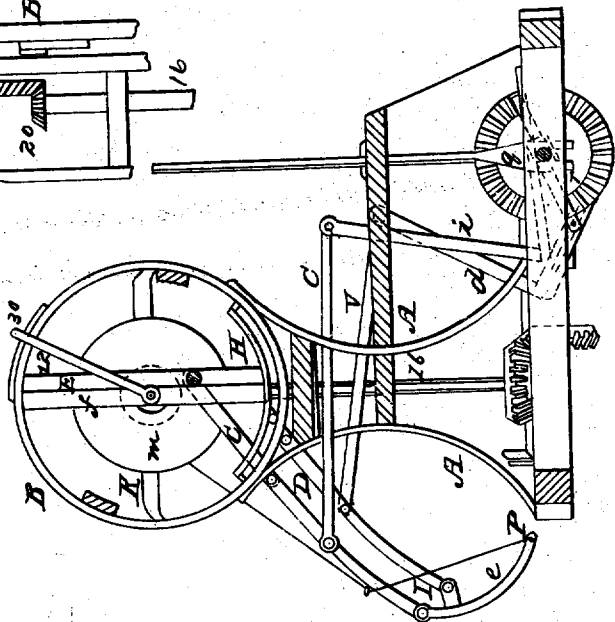

Fig. 3,

Fig. 1,



WITNESSES:
C. M. Alexander
A. A. Yeaman

INVENTOR:
L. P. Harris

UNITED STATES PATENT OFFICE.

L. P. HARRIS, OF MANSFIELD, OHIO.

IMPROVEMENT IN BINDING ATTACHMENTS TO HARVESTERS.

Specification forming part of Letters Patent No. 31,540, dated February 26, 1861.

To all whom it may concern :

Be it known that I, L. P. HARRIS, of Mansfield, in the county of Richland, in the State of Ohio, have invented a new and Improved Binding Attachment to Harvesters; and I do hereby declare that the following is a full and exact description thereof, reference being had to the accompanying drawings, and to the letters of reference marked thereon.

The nature of my invention consists in the construction and arrangement of machinery by which grain may be rapidly bound by hand-power or by horse-power, or whatever power is employed in propelling the reaper, substantially as hereinafter described.

To enable others skilled in the art to make and use my invention, I will proceed to describe its construction and operation.

The standards A and a, in Figures 1 and 4, may be constructed of wood or iron, of a convenient height for the attachment of the circular tops B. Two of these circular tops are arranged side by side, and firmly attached to each other, at a sufficient distance from each other to allow of a free motion of the bars C and D between them. They are also provided with the cross-bars E and F, for the support of the shaft G and the ends of the bar C. These circular tops are also each provided with a circular slot, H, for the purpose of controlling the motion of the end of the bar D in expanding and closing the arm I. The standard a is secured at a convenient distance from the standard A, and rises high enough so that the cross-bar K supports the shaft G, on which are the spool L and wheel m, and the indicator n. The arm I is composed of three bars, C, D, and e, the bars C and D being connected to the bar e by a hinged joint, as seen at I. The end of the bar C is hinged to the cross-bar E by means of a short bolt. The end of the bar D has a short bolt passing through it, the ends of which project into the circular slot H. The bar e is provided with a small projection at the point P, which is pierced with a small hole, through which the wire passes. O, in Fig. 2, represents the frame of a reaper. M is the axle of the reaper. S is a cog-wheel on said axle, which connects, at f, with the shaft t, on which are adjusted the drivers b, l, and r, also the wheel y. The drivers b and l are used to op-

erate the arm by their connection with the elbows and lever i e and d v. The driver r is used to operate the wheel y, which drives the shaft 8, by its connection at 4. The spiral springs 5, 6, and 7 are also adjusted upon the shaft t, for the purpose of disconnecting the drivers C and l, with the elbows i and d and the drivers r, from the wheel y whenever desired. The lever 9 is used to operate the drivers C and l, bringing them into contact with the elbows i and d whenever it is desired to operate the arm I. The lever 10 is used to operate the driver r, bringing it into contact with a pin in the wheel y whenever it is desired to operate the shaft 8, as in twisting the band in binding grain. The lever 12 is used to operate the shears 11 in cutting the wire previous to twisting it. 13 is a spring, being bent at right angles to correspond with a similar angle at the end of the shaft 8, for the purpose of holding the wire or band while twisting it. 11, in Fig. 3, represents the shears used for cutting the wire. 14 are two springs, operating together to hold the wire when the arm is raised previous to grasping the sheaf, as in Fig. 1. 16, in Fig. 1, is a vertical shaft, connected with the shaft 8, also the shaft G, at 20, for the purpose of operating the binder by hand-power whenever desired. 18 is a crank, to which the hand-power is applied. n is an indicator, by which the position of the angle of the shaft 8 and the spring 13 is regulated, preparatory to receiving the wire from the point of the arm P in its passage under the spring in grasping the sheaf. L is a deep spool or reel, on which the wire for bands is placed.

Having the various parts of the binder properly adjusted in relation to each other, I then adjust the binder upon the reaper in the most convenient position to receive the grain from the raker, who stands upon the corner of the frame-work of the reaper in such a position that the grain is readily placed within the grasp of the arm I by the raker. The position, however, may be changed, according to the construction of the reaper, and the shafts r and 8 arranged accordingly.

The mode of operating the binder is as follows: A proper supply of wire suitable for bands is first placed upon the spool L, the end of

which is carried through proper supports along the arm, and through the hole P at the point. The arm is then closed, carrying the end of wire through the springs 14. The arm is then raised, carrying the wire through the shears, which are open, also through the angular spring 13, leaving the end of the wire in the spring 13. The reaper now being set in motion, the drive-wheels and axle, in their revolutions, carry with them the wheel S, which also operates the shaft t, causing it to revolve with the motion of the reaper, carrying with it drivers b, l, and r, by which means the levers 9 and 10 may in a moment be thrown into contact with the elbows i or d, or with the wheel y. When it is desired to raise the arm of the binder, a slight backward motion of the lever 9 throws the driver b into contact with the elbows i, and the arm is immediately thrown up and sustained by a spring, when a slight forward motion of the lever 9 allows the driver b to be thrown out of contact by the spiral spring 7. Another slight forward motion of the lever 9 throws the driver l into contact with the elbow d, when the arm immediately closes, grasping the sheaf, carrying the wire through the angular spring 13 and shears 11, also the spring 14. Thus the wire is carried from the springs 14 around the sheaf to the point from whence it started. The lever 12 is then brought forward, closing the shears to cut the wire, also carrying forward the lever 10, by which the driver r is thrown in contact with the wheel y, which drives the shaft 8, and the wire is instantly twisted, when a backward motion of the levers 10 and 12 again opens the shears, and disconnects the driver r and wheel y by means of the spiral spring 5. Thus, in a moment, the sheaf is grasped and bound, when the arm may instantly be thrown up again, leaving the end of wire in the springs 14.

In operating the binder by hand-power, which is done with ease and readiness, all the machinery connecting the reaper and binder should be removed, thereby avoiding much friction. Changed to a convenient position, the lever is used for cutting the wire, so that one hand of the operator may control the arm of the binder, while the other hand operates the crank for twisting the wire.

It will be observed that the indicator revolves with the shaft 9, and should be allowed to make one revolution, as indicated by the spring 30. The indicator should be placed in contact with the spring 30 before elevating or closing the arm, thereby placing the angular spring in a proper position for the passage of the point of the arm and wire. The lines 40 40 represent the platform of the reaper.

What I claim as my invention, and desire to secure by Letters Patent, is—

1. The arrangement of the standards A a, in combination with the circular tops B B, substantially as described, and for the purposes set forth.
2. The arrangement of the bars C, D, and e, composing the arm I, with the standards and circular slots H, substantially as described, and for purposes set forth.
3. The arrangement of mechanism for operating the bars C and D, for expanding and closing the arm I, substantially as described.
4. The arrangement of the angular spring 13, shears 11, and springs 14, substantially as described, and for purposes set forth.
5. The arrangement of the drivers C, l, and r, spiral spring 5, 6, and 7, and wheel y, substantially in the manner set forth.

L. P. HARRIS.

Witnesses.

H. L. KING,
L. ROBERTS.