

No. 736,072.

PATENTED AUG. 11, 1903.

H. S. COLE.
ARM REST FOR CRUTCHES.
APPLICATION FILED APR. 1, 1903.

NO MODEL.

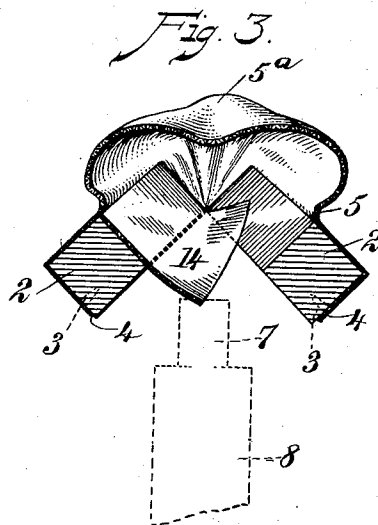
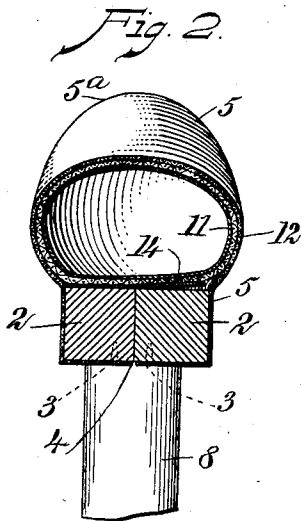
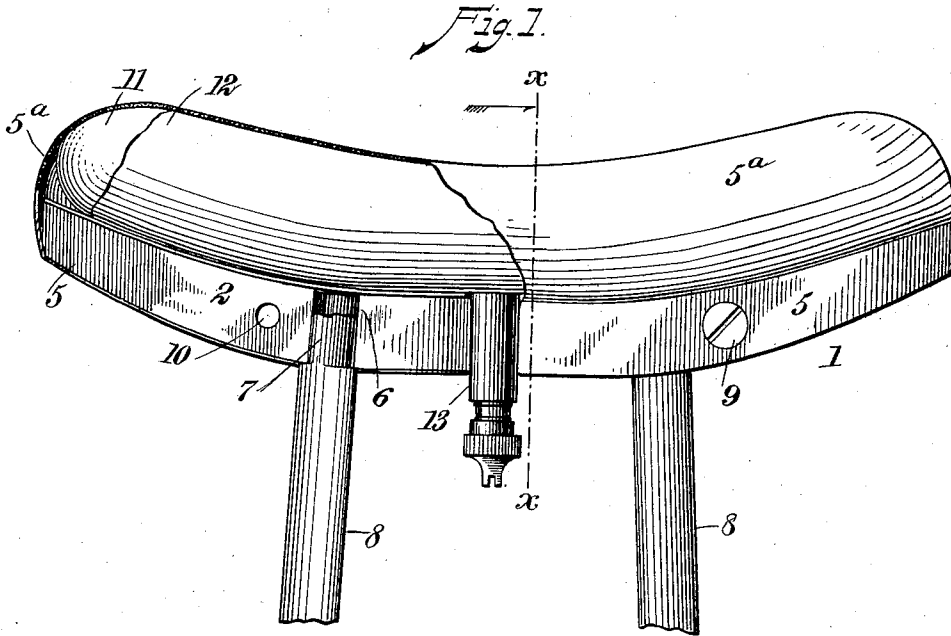

WITNESSES:

Robert Head
E. Collins

INVENTOR
Harry S. Cole
BY *Mumford*
ATTORNEYS.

UNITED STATES PATENT OFFICE.

HARRY S. COLE, OF NEWTONSVILLE, OHIO.

ARM-REST FOR CRUTCHES.

SPECIFICATION forming part of Letters Patent No. 736,072, dated August 11, 1903.

Application filed April 1, 1903. Serial No. 150,538. (No model.)

To all whom it may concern:

Be it known that I, HARRY S. COLE, a citizen of the United States, and a resident of Newtonsville, in the county of Clermont and State of Ohio, have invented a new and Improved Head or Arm-Rest for Crutches, of which the following is a full, clear, and exact description.

This invention relates to crutches; and it consists substantially in the construction, organization, and combination of parts herein-after particularly described and claimed.

The invention has reference more particularly to heads or arm-rests for crutches, and the principal object of the invention is to provide a device or structure of its kind which may be readily attached to or detached from the upper ends or extremities of the uprights or standards of a crutch and also to provide such a device with means whereby a comfortable yielding action is derived therefrom in the use of the crutch.

A further object is to provide a device of the kind referred to which is simple in construction and capable of adjustment to varying degrees of elasticity, accordingly as may be required in use, and one also possessing durability and strength and having the capacity for long and repeated service.

A still further object of the invention is to provide a head or arm-rest for crutches which is light in weight and comparatively cheap to manufacture, besides being capable of easy handling and manipulation, both in the attachment and detachment to or from the standards or uprights of the crutch.

The above and additional objects are attained by means substantially such as are illustrated in the accompanying drawings, in which—

Figure 1 is a side view, partly broken away, of a head or arm-rest for crutches embodying my improvements. Fig. 2 is a transverse sectional view taken on the line xx in Fig. 1; and Fig. 3 is a similar view showing the longitudinal members of the head or arm-rest in separated condition, thus to illustrate the operation thereof on the insertion or removal of the elements or parts contained within the sheath or outer covering for the device.

Before proceeding with a more detailed description it may be stated that in the em-

bodiment of my invention herein shown I provide the head or arm-rest for the crutch with a base of special construction, to which is attached or secured in any suitable manner a sheath or outer covering of any desired material, which is also of special construction, to adapt the same for the reception of an inner elastic tube provided with means for inflating the same with air, said tube being provided with an inclosing casing for preserving the shape of the tube when the latter is inflated and which also prevents bursting of the said tube from undue pressure.

While I have herein represented a certain preferred embodiment of my improved device, it will be understood that I am not limited to the precise details thereof in practice, since immaterial changes therein may be resorted to coming within the scope of my invention.

Specific reference being had to the several parts of the drawings by the designating characters marked thereon, 1 represents the base of the head or arm-rest for a crutch, the same being constructed of duplicate strips 2 2 of wood or other suitable material having the proper curvature to conform to the arm-pit of the user of the device, and attached or secured to the underside of each of said strips, as by means of tacks 3 or in any other suitable manner, are the longitudinal edges 4 of a sheath or outer covering 5, which latter is cut or formed to closely fit the sides of the said strips 2 2, and also with sufficient fullness to form practically a pocket 5^a, it being remarked at this point that the said sheath or outer covering may be made of rubber, cloth, leather, or any other desired material. From the construction thus described it will appear that the said duplicate strips 2 2 constitute practically a clamp, and, as shown in Fig. 1, each strip is correspondingly recessed at 6, on opposite sides of the longitudinal center thereof, for the reception of dowels at the upper ends of the standards or uprights 8 8 of the crutch, and when these dowels are properly inserted in place between the inner sides of the said duplicate strips and screws or other fastening devices 9 are passed through openings 10 therefor in the strips and properly secured it is apparent that the head or arm-rest will be firmly fastened in position at the upper ends of the said standards or up-

rights. Fig. 3 indicates the manner of separating the strips for the purpose of attaching or detaching the head or arm-rest to or from the standards or uprights whenever desired.

5 Contained in the pocket formed by the sheath or outer covering 5 is a rubber or other elastic tube 11, which is contained in an inclosing case 12 of canvas or other suitable material, which serves to preserve the general shape of the tube when inflated with air, besides also confining the tube within prescribed limits of expansion and preventing bursting of the same from undue pressure within. For the purpose of inflating or deflating the inner elastic tube I provide a valved connection 13, passing through the base of the head or arm-rest and communicating with the inner inflatable tube after 20 passing through a suitable opening therefor in the inclosing casing for said tube. Referring to Figs. 2 and 3, it will be seen that I also sometimes employ a closing-flap 14 of any suitable material for rendering the joint between the adjacent sides of the duplicate curved strips 22 air-tight; but the use of this flap is not necessary in all instances. It is evident that I may attach or secure the longitudinal edges of the sheath or outer covering to the under side of the duplicate strips in any other desired way from that herein shown, and it is also apparent that other materials than those herein specified may be employed for the construction of the different elements or parts of the structure, it being added that 35 in forming the inflated tube and its inclosing casing the same are given a shape to conform

to the general curvature of the strips of the base, by which to give to the structure an elastic or yieldable action, by which all jarring and soreness to the arm of the user is obviated. A head or arm-rest of this character also is less liable to wear out adjacent parts of the garments or clothing of the user, and it possesses a great many other advantages 45 with many similar devices hitherto devised with like objects in view.

Having thus described my invention, I claim as new and desire to secure by Letters Patent—

1. An arm-rest for crutches, comprising duplicate strips, a sheath or casing having its edges passed around and beneath said strips and secured to the under sides of the latter, these strips being constructed on their inner 55 faces to receive the upper ends of the standards of a crutch, means for securing the strips together, an elastic tube within said sheath, and a valved tube for enabling inflation of said elastic tube to be effected. 60

2. A head or arm-rest for crutches, comprising duplicate curved strips, movably joined together in parallelism, means for securing the strips together, a sheath or outer covering attached to the strips at the lower 65 edges thereof, an inner inflatable tube, and an inclosing casing for said tube.

In testimony whereof I have signed my name to this specification in the presence of two subscribing witnesses.

HARRY S. COLE.

Witnesses:

W. L. WARE,
MARY E. COLE.